

GENERAL DESCRIPTION

The SGM41107A is designed for primary protection of Li-Ion/polymer rechargeable cells. The product integrates all the protections required for safe operation of polymer rechargeable cells. The device is packaged in a tiny and thin package. Its small solution size leaves more space for fitting the battery cell into a given cavity for small size wearable devices.

The SGM41107A integrates all the protections and the required low on-resistance disconnect switch on one die. The protection functions include charge and discharge protection, mainly detecting and protecting battery over-charge, over-discharge and over-current. The product also disconnects the battery pack in the case of deep discharge.

The SGM41107A operates in -40°C to +85°C temperature range, and is in a thin and low profile XTDFN-1×1-4L package. This package with a maximum height of 0.4mm is convenient for small cell packing designs.

APPLICATIONS

- IoT Gadgets
- Wearable Devices
- Battery Packs

FEATURES

- Ultra-Compact Protection Solution
- Pass Resistance: 75mΩ (TYP)
- Operation Current: 1.25μA (TYP)
- Factory Programmable Over-Voltage Threshold: 4.3V to 4.69V with 10mV per Step
- Over-Charge/Discharge Current Protection
- Over-Discharge Detection Voltage Control 1/2
- Discharge Short Protection
- Shipping Mode
- Power-On Self-Locking
- Battery Under-Voltage Protection: 2.2V to 3.35V with 50mV per Step
- 0V Battery Charge Function: Enable
- 10nA (TYP) Deep Discharge Shutdown
- Input Over-Voltage Safe
- Load Short-Circuit Safe
- Battery Reverse Polarity Safe
- Battery Pack Paralleling Safe
- Shutdown for Delivery/Assembly
- Available in a Green XTDFN-1×1-4L Package

SIMPLIFIED SCHEMATIC

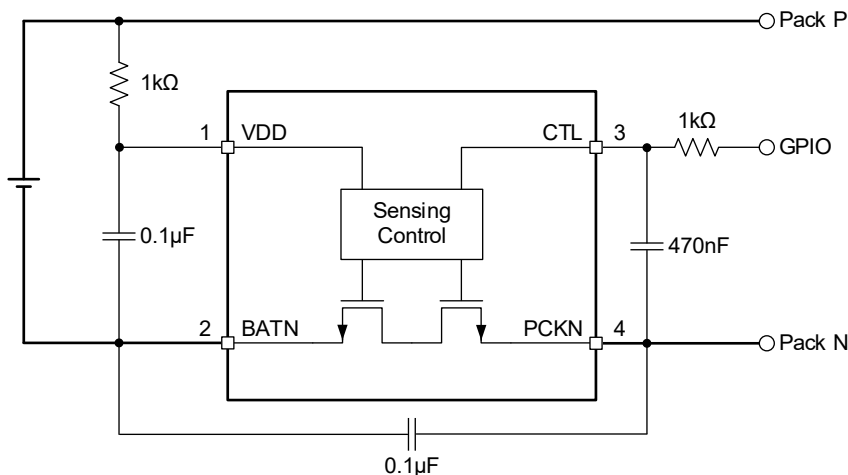

Figure 1. Simplified Schematic

PACKAGE/ORDERING INFORMATION

MODEL	PACKAGE DESCRIPTION	SPECIFIED TEMPERATURE RANGE	ORDERING NUMBER	PACKAGE MARKING	PACKING OPTION
SGM41107A-455N61	XTDFN-1×1-4L	-40°C to +85°C	SGM41107A-455N61YXDH4G/TR	7M	Tape and Reel, 10000
SGM41107A-45NN21	XTDFN-1×1-4L	-40°C to +85°C	SGM41107A-45NN21YXDH4G/TR	7P	Tape and Reel, 10000
SGM41107A-50EJC1	XTDFN-1×1-4L	-40°C to +85°C	SGM41107A-50EJC1YXDH4G/TR	7K	Tape and Reel, 10000
SGM41107A-50EJ61	XTDFN-1×1-4L	-40°C to +85°C	SGM41107A-50EJ61YXDH4G/TR	7L	Tape and Reel, 10000
SGM41107A-53PF61	XTDFN-1×1-4L	-40°C to +85°C	SGM41107A-53PF61YXDH4G/TR	7G	Tape and Reel, 10000
SGM41107A-55NJ61	XTDFN-1×1-4L	-40°C to +85°C	SGM41107A-55NJ61YXDH4G/TR	7O	Tape and Reel, 10000
SGM41107A-58GC61	XTDFN-1×1-4L	-40°C to +85°C	SGM41107A-58GC61YXDH4G/TR	84	Tape and Reel, 10000
SGM41107A-62PF61	XTDFN-1×1-4L	-40°C to +85°C	SGM41107A-62PF61YXDH4G/TR	7F	Tape and Reel, 10000
SGM41107A-62LC61	XTDFN-1×1-4L	-40°C to +85°C	SGM41107A-62LC61YXDH4G/TR	7H	Tape and Reel, 10000
SGM41107A-62KA61	XTDFN-1×1-4L	-40°C to +85°C	SGM41107A-62KA61YXDH4G/TR	7I	Tape and Reel, 10000
SGM41107A-62PFC1	XTDFN-1×1-4L	-40°C to +85°C	SGM41107A-62PFC1YXDH4G/TR	7J	Tape and Reel, 10000
SGM41107A-62KGC1	XTDFN-1×1-4L	-40°C to +85°C	SGM41107A-62KGC1YXDH4G/TR	7A	Tape and Reel, 10000

NOTE: For more parts, please refer to Table 1 and contact with SGMICRO.

MARKING INFORMATION

YY

Serial Number

Green (RoHS & HSF): SG Micro Corp defines "Green" to mean Pb-Free (RoHS compatible) and free of halogen substances. If you have additional comments or questions, please contact your SGMICRO representative directly.

DEVICE DESCRIPTION

Table 1. Key Parameters and Options/Part Numbering

Model: SGM41107A-AABCDE									
Over-Voltage Threshold Options									
Option Code "AA"	30	31	32	33	34	35	36	37	
Over-Voltage Threshold V_{OV} (V)	4.30	4.31	4.32	4.33	4.34	4.35	4.36	4.37	
Option Code "AA"	38	39	40	41	42	43	44	45	
Over-Voltage Threshold V_{OV} (V)	4.38	4.39	4.40	4.41	4.42	4.43	4.44	4.45	
Option Code "AA"	46	47	48	49	50	51	52	53	
Over-Voltage Threshold V_{OV} (V)	4.46	4.47	4.48	4.49	4.50	4.51	4.52	4.53	
Option Code "AA"	54	55	56	57	58	59	60	61	
Over-Voltage Threshold V_{OV} (V)	4.54	4.55	4.56	4.57	4.58	4.59	4.60	4.61	
Option Code "AA"	62	63	64	65	66	67	68	69	
Over-Voltage Threshold V_{OV} (V)	4.62	4.63	4.64	4.65	4.66	4.67	4.68	4.69	
Under-Voltage Threshold Options									
Option Code "B"/"C"	A	B	C	D	E	F	G	H	
Under-Voltage Threshold $V_{UV1/2}$ (V)	2.2	2.25	2.3	2.35	2.4	2.45	2.5	2.55	
Option Code "B"/"C"	J	K	L	M	N	P	R	S	
Under-Voltage Threshold $V_{UV1/2}$ (V)	2.6	2.65	2.7	2.75	2.8	2.85	2.9	2.95	
Option Code "B"/"C"	T	1	2	3	4	5	6	7	
Under-Voltage Threshold $V_{UV1/2}$ (V)	3.0	3.05	3.1	3.15	3.2	3.25	3.3	3.35	
Current Threshold Combination Options									
Option Code "D"	1		2		3		C		
Over-Charge Current I_{OC} (A)	0.12		0.25		0.35		1.45		
Over-Discharge Current I_{OD} (A)	0.12		0.20		0.30		1.20		
Short-Circuit Current (A)	1.1							1.55	
0V Charge Function Option									
Option Code "E"	1								
0V Charge Function Permission	Enable								

NOTE: Samples are only available for some part numbers. Contact SGMICRO for sample availability.

BSOLUTE MAXIMUM RATINGS

VDD to PCKN, 12V ⁽¹⁾ , 10mA Clamping ⁽²⁾	5s
VDD to PCKN	-5V or +9V ⁽³⁾ , Continuous
CTL to BATN	±6V
Pack P to BATN	-5V ⁽³⁾ or +6V
Pack P to Pack N Short-Circuit ⁽⁴⁾	Continuous
Pack P to BATN Attachment Inrush/Outrush	±5V
Package Thermal Resistance	
XTDFN-1×1-4L, θ_{JA}	136.7°C/W
XTDFN-1×1-4L, θ_{JB}	72.8°C/W
XTDFN-1×1-4L, $\theta_{JC (TOP)}$	108.8°C/W
XTDFN-1×1-4L, $\theta_{JC (BOT)}$	71.4°C/W
Junction Temperature	+150°C
Storage Temperature Range	-65°C to +150°C
Lead Temperature (Soldering, 10s)	+260°C
ESD Susceptibility ^{(5) (6)}	
HBM	±4000V
CDM	±1000V

NOTES:

1. Evaluation at $V_{BAT} = 4.5V$.
2. The clamping may reach 10mA at an input voltage > 12V.
3. Test with a voltage regulated supply that has 2A current limit and increase the voltage progressively for less than 1V/ms slope rate. Apply a voltage to the device under test from 0V to given voltages.
4. The device is tested after being installed on the circuit board in Figure 1. Clip a 4.5V, 5A power source onto the Pack P and BATN to simulate a battery and short the Pack P and the Pack N with an 80mΩ wire.
5. For human body model (HBM), all pins comply with ANSI/ESDA/JEDEC JS-001 specifications.
6. For charged device model (CDM), all pins comply with ANSI/ESDA/JEDEC JS-002 specifications.

RECOMMENDED OPERATING CONDITIONS

Supply Voltage Range	0V to 6V
Battery Voltage Range	0V to 4.7V
Operating Ambient Temperature Range	-40°C to +85°C
Operating Junction Temperature Range	-40°C to +125°C

OVERSTRESS CAUTION

Stresses beyond those listed in Absolute Maximum Ratings may cause permanent damage to the device. Exposure to absolute maximum rating conditions for extended periods may affect reliability. Functional operation of the device at any conditions beyond those indicated in the Recommended Operating Conditions section is not implied.

ESD SENSITIVITY CAUTION

This integrated circuit can be damaged if ESD protections are not considered carefully. SGMICRO recommends that all integrated circuits be handled with appropriate precautions. Failure to observe proper handling and installation procedures can cause damage. ESD damage can range from subtle performance degradation to complete device failure. Precision integrated circuits may be more susceptible to damage because even small parametric changes could cause the device not to meet the published specifications.

DISCLAIMER

SG Micro Corp reserves the right to make any change in circuit design, or specifications without prior notice.

PIN CONFIGURATION

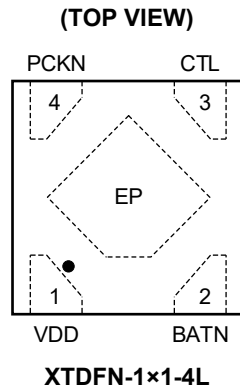

PIN DESCRIPTION

PIN	NAME	TYPE	FUNCTION
1	VDD	P	Device Bias Supply/Battery Voltage Sensing Input. Place a capacitor between this pin and BATN pin, and place a 1kΩ resistor between the pin and the battery pack positive connection.
2	BATN	P	Switch Terminal: Connects to the Negative Pole of the Battery.
3	CTL	AI	Shipping Mode Control and Under-Voltage Protection Selection Pin.
4	PCKN	P	Switch Terminal: Connects to the Negative Terminal of the System Load.
Exposed Pad	EP	—	Package Exposed Pad with No Internal Connection. External connection to the BATN is recommended.

NOTE: AI = analog input, P = power.

ELECTRICAL CHARACTERISTICS

(Battery voltage $V_{BAT} = 3.7V$, $T_J = -25^{\circ}C$ to $+70^{\circ}C$, typical values are measured at $T_J = +25^{\circ}C$, unless otherwise noted.)

PARAMETER	SYMBOL	CONDITIONS	MIN	TYP	MAX	UNITS	
Operating Current	I_{OP}	$T_J = +25^{\circ}C$		1.25	2	μA	
		$T_J = -25^{\circ}C$ to $+70^{\circ}C$			3		
Shipping Mode Current	I_{SM}	The stable current flowing into the device when the device is set into shipping mode	$T_J = +25^{\circ}C$	10	50	nA	
			$T_J = -25^{\circ}C$ to $+70^{\circ}C$				100
0V Battery Charge Starting Charger Voltage	V_{0CHA}	$T_J = +25^{\circ}C$	0.90	1.05	1.25	V	
		$T_J = -25^{\circ}C$ to $+70^{\circ}C$	0.65	1.05	1.50		
Over-Charge Detection Voltage	V_{OV}	$T_J = +25^{\circ}C$	$V_{OV} - 0.025$	V_{OV}	$V_{OV} + 0.025$	V	
		$T_J = -25^{\circ}C$ to $+70^{\circ}C$	$V_{OV} - 0.035$	V_{OV}	$V_{OV} + 0.035$		
Over-Charge Hysteresis Voltage	V_{OVHYS}			210		mV	
Over-Discharge Detection Voltage 1	V_{UV1}	$T_J = +25^{\circ}C$	$V_{UV1} - 0.07$	V_{UV1}	$V_{UV1} + 0.07$	V	
		$T_J = -25^{\circ}C$ to $+70^{\circ}C$	$V_{UV1} - 0.1$	V_{UV1}	$V_{UV1} + 0.1$		
Over-Discharge Detection Voltage 2	V_{UV2}	$T_J = +25^{\circ}C$	$V_{UV2} - 0.05$	V_{UV2}	$V_{UV2} + 0.05$	V	
		$T_J = -25^{\circ}C$ to $+70^{\circ}C$	$V_{UV2} - 0.07$	V_{UV2}	$V_{UV2} + 0.07$		
Over-Discharge Detection Current	I_{OD}	SGM41107A-____2_	$T_J = +25^{\circ}C$	110	200	300	mA
			$T_J = -25^{\circ}C$ to $+70^{\circ}C$	90	200	320	
		SGM41107A-____6_	$T_J = +25^{\circ}C$	400	550	700	
			$T_J = -25^{\circ}C$ to $+70^{\circ}C$	350	550	750	
		SGM41107A-____C_	$T_J = +25^{\circ}C$	900	1200	1500	
			$T_J = -25^{\circ}C$ to $+70^{\circ}C$	700	1200	1700	
Over-Charge Detection Current	I_{OC}	SGM41107A-____2_	$T_J = +25^{\circ}C$	160	250	340	mA
			$T_J = -25^{\circ}C$ to $+70^{\circ}C$	140	250	360	
		SGM41107A-____6_	$T_J = +25^{\circ}C$	500	680	800	
			$T_J = -25^{\circ}C$ to $+70^{\circ}C$	450	680	850	
		SGM41107A-____C_	$T_J = +25^{\circ}C$	1100	1450	1850	
			$T_J = -25^{\circ}C$ to $+70^{\circ}C$	1000	1450	1900	
Discharge Short-Circuit Detection Current	I_{SHORT}	SGM41107A-____1/2/3/6_	$T_J = +25^{\circ}C$	0.8	1.1	1.4	A
			$T_J = -25^{\circ}C$ to $+70^{\circ}C$	0.6	1.1	1.6	
		SGM41107A-____C_	$T_J = +25^{\circ}C$	1.2	1.55	2.0	
			$T_J = -25^{\circ}C$ to $+70^{\circ}C$	1.0	1.55	2.1	
Pass Resistance	R_P	$T_J = +25^{\circ}C$		75	90	m Ω	
		$T_J = -25^{\circ}C$ to $+70^{\circ}C$		75	100		
Voltage between BATN and PCKN during Charging under UVP	V_{B_P}	$T_J = -25^{\circ}C$ to $+70^{\circ}C$		160	300	mV	
CTL Pin Active Voltage	V_{CTL1}	The under-voltage protection threshold is set to V_{UV1}			0.4	V	
	V_{CTL2}	The under-voltage protection threshold is set to V_{UV2}	0.55		1.15	V	
	V_{CTL3}	The device goes into shipping mode	1.35			V	

ELECTRICAL CHARACTERISTICS (continued)(Battery voltage $V_{BAT} = 3.7V$, $T_J = -25^{\circ}C$ to $+70^{\circ}C$, typical values are measured at $T_J = +25^{\circ}C$, unless otherwise noted.)

PARAMETER	SYMBOL	CONDITIONS	MIN	TYP	MAX	UNITS
Over-Voltage Detection Delay ⁽¹⁾	t_{OV}	$T_J = +25^{\circ}C$	0.7	1	1.3	s
		$T_J = -25^{\circ}C$ to $+70^{\circ}C$	0.5	1	1.5	
Under-Voltage Detection Delay ⁽¹⁾	t_{UV}	$T_J = +25^{\circ}C$	20	29	44	ms
		$T_J = -25^{\circ}C$ to $+70^{\circ}C$	16	29	60	
Over-Discharge Current Detection Delay ⁽¹⁾	t_{ODC}	$T_J = +25^{\circ}C$	20	29	44	ms
		$T_J = -25^{\circ}C$ to $+70^{\circ}C$	16	29	60	
Over-Charge Current Detection Delay ⁽¹⁾	t_{OCC}	$T_J = +25^{\circ}C$	4.8	11	15	ms
		$T_J = -25^{\circ}C$ to $+70^{\circ}C$	3.8	11	20	
Discharge Short-Circuit Detection Delay ⁽¹⁾	t_{OCSD}	$T_J = +25^{\circ}C$	0.196	0.27	0.5	ms
		$T_J = -25^{\circ}C$ to $+70^{\circ}C$	0.140	0.27	0.7	

NOTE: 1. Parameters guaranteed by design.

TYPICAL PERFORMANCE CHARACTERISTICS

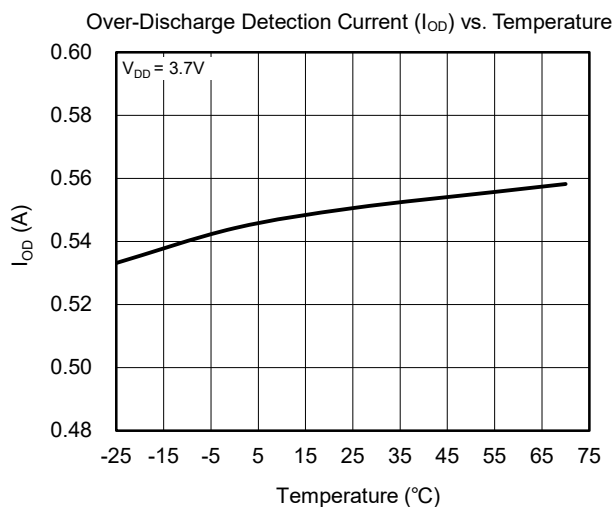
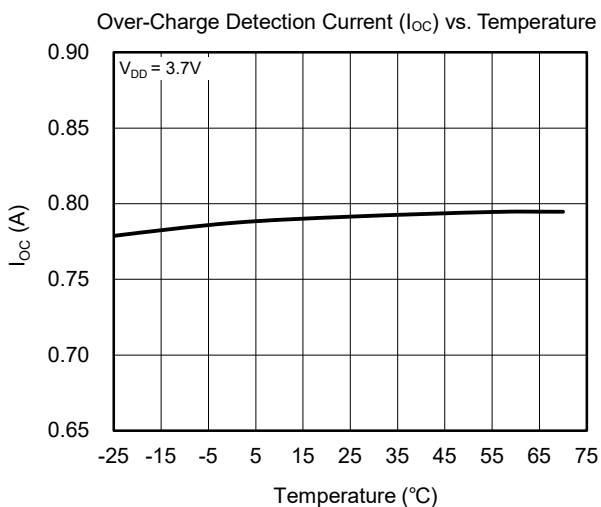
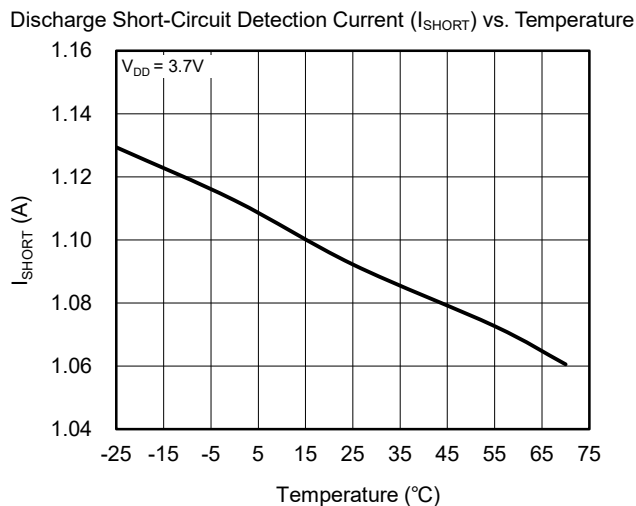
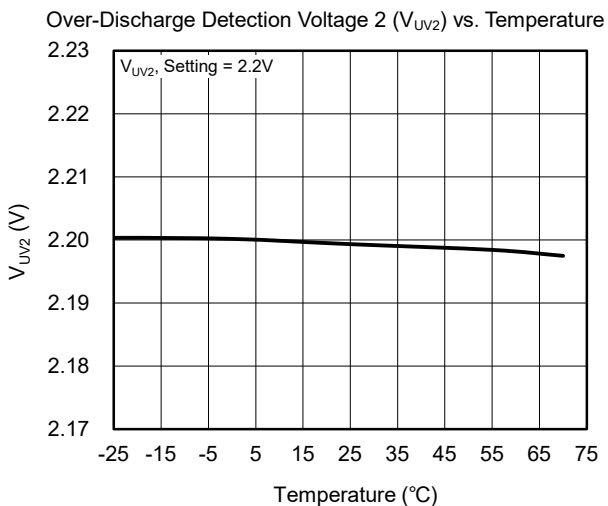
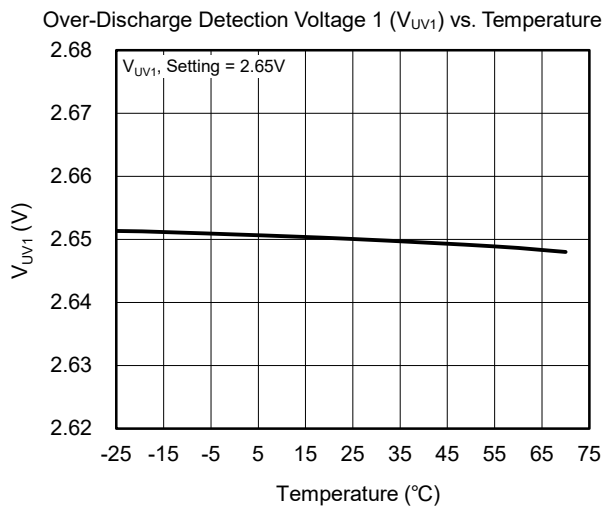
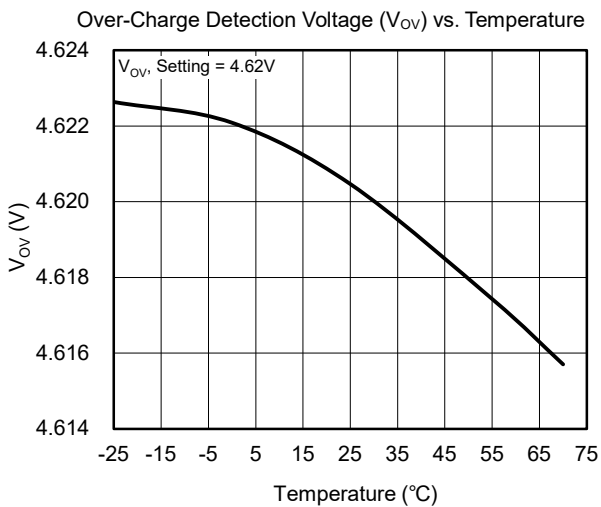

TYPICAL PERFORMANCE CHARACTERISTICS (continued)

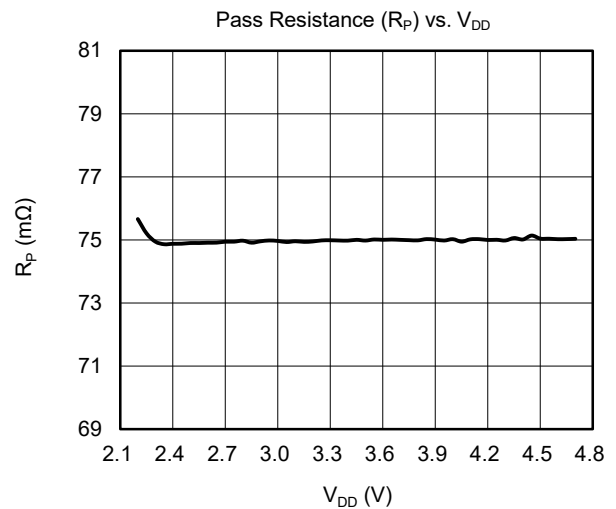
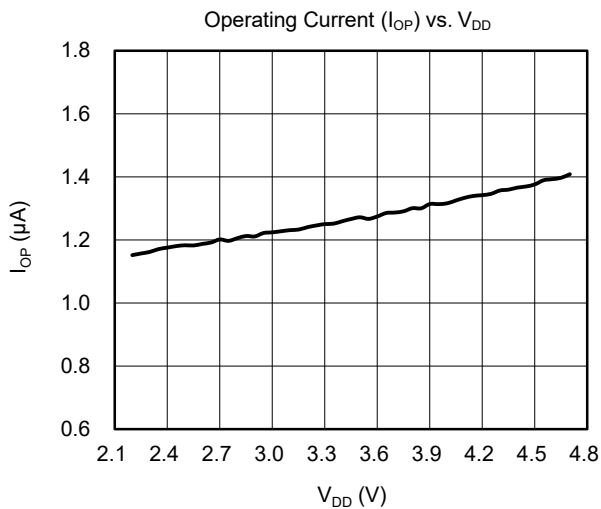
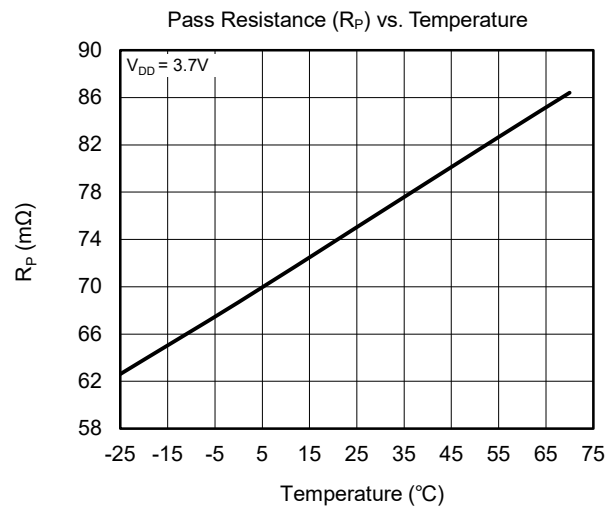
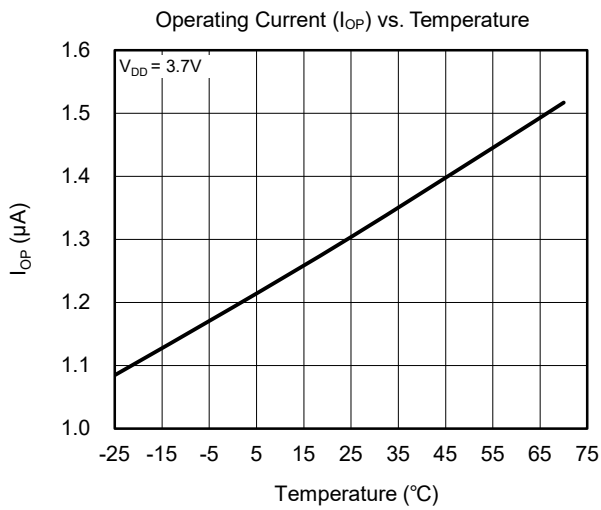

DETAILED DESCRIPTION

The SGM41107A is a Li-Ion/polymer battery protector with integrated battery switch. It provides a full set of protection functions on voltage and current, and can disconnect the battery using the integrated switch. To reduce the power consumption, the battery voltage and current are measured periodically (polling), but the short-circuit condition is continuously monitored when the switch is turned on so that the device can instantly respond and turn off the switch if a suspicious short is detected in the load.

Voltage Related Protections

The battery voltage, sensed between the VDD and BATN pins, is monitored periodically (with deglitch time) while the charge input and battery connection are detected instantly.

During charging, in every detection cycle, the battery is checked for over-voltage. When a high battery voltage is detected ($V_{BAT} > V_{OV}$), the battery switch is turned into charge block mode to prohibit any further charging and allows current only in the discharge direction. The charge is unblocked when the battery voltage drops to over-charge release voltage ($V_{OV} - 210\text{mV}$) due to discharge. The battery over-voltage threshold (V_{OV}) depends on the selected "AA" code of the device.

During discharging, in every detection cycle, the battery is checked for low voltage. When a low battery voltage is detected ($V_{BAT} < V_{UV1}$ or $V_{BAT} < V_{UV2}$, depending on CTL voltage), the battery switch blocks battery discharge direction and the device goes to under-voltage protection status. The battery switch allows current only in the charge direction, and the charge over-current detection does not function in the under-voltage protection status. The battery low voltage threshold (V_{UV1} and V_{UV2}) depends on the selected "B" and "C" codes of the device. And the device releases the under-voltage protection status only when the charger is detected and the battery voltage rises above V_{UV} (over-discharge detection voltage).

Current Related Protections

When a charger is connected, if over-charge current reaches I_{OC} and lasts for t_{OCC} or longer, the SGM41107A enters over-charge current state and the status is released when the discharge current flows and the load is connected.

When over-discharge current condition occurs and keeps for over-discharge current detection delay (t_{ODC}), the discharge path closes. The SGM41107A enters over-discharge current state and the status is released when the charge is detected.

Short-Circuit Protection

When discharge current exceeds short-circuit current threshold (I_{SHORT}), discharge path disconnects instantly in t_{OCS} , in order to protect the battery from potential over-current stress. When the charger is detected, it releases the status.

0V Voltage Charging Function

This feature enables recharging an attached battery that has very low voltage. When the charger is connected voltage is approximately 1.05V, the charging starts. If the battery voltage is in the range of 0V to V_{UV} , the charge MOSFET is turned on and the charge current flows through the discharge MOSFET body diode.

Power-On Self-Locking Function

The SGM41107A is self-locked and the battery cannot discharge at first welding. The status is released when the charger is detected.

Battery Reverse Polarity Attachment

In the case of reverse battery attachment, the current into the load is not blocked by the device. The reverse current will not damage the device and it is safe unless the current is too high and results in overheating damage.

Control Pin Function

CTL Pin Active UVP1

When the CTL pin voltage is equal to or lower than 0.4V and lasts for 2.2s or longer, the under-voltage protection threshold is set to V_{UV1} .

CTL Pin Active UVP2

When the CTL pin voltage is higher than 0.55V and lower than 1.15V and lasts for 13ms or longer, the under-voltage protection threshold is set to V_{UV2} .

CTL Pin Active Shipping Mode

When the CTL pin voltage is equal to or higher than 1.35V and lasts for 0.56s or longer, the SGM41107A turns off the charge and discharge MOSFETs and the charging and discharging is stopped.

DETAILED DESCRIPTION (continued)

Parallel Battery Packs

When two battery packs are connected in parallel utilizing SGM41107As, a momentary current surge may cause charge over-current protection in the pack with the lower voltage. The higher voltage pack could enter a discharge over-current protection. The charge over-current or discharge over-current protection resets only after the higher voltage battery pack discharges to a voltage slightly higher than the lower voltage pack. After this discharge, both packs can conduct.

Caution: The battery short or load side terminal short outside the protection circuit's loop during battery attaching may cause excessive high surge current and excessive high current-breaking voltage surge, which may cause damage or degrade the life duration of battery and protection circuit. It is recorded that the accidental anode to ground plane shorting causes heavy surge, which can actually be avoided by leaving enough clearance around the anode pad on PCB or soldering/attaching the anode firstly in assembly (as the short between cathode to ground will not cause excessive surge).

Cautions for Application

Caution about ESD damage to the battery: The battery pack might be the biggest element in equipment and induce much during an ESD event. Careful design of guided discharge path is desired for the equipment case sealing air-gap discharge over the battery and those connected to the battery closely.

Caution on electrochemical corrosion: As a battery can apply potential over the electrodes continuously and cause electrochemical corrosion, the corrosion product may spread in the hollow beneath a surface mount device and cause leakage. Moisture-proof coating is recommended, especially when using compact devices.

Cautions for Evaluation Test

Some types of electronic load simulators may have excessive inrush current, and some BPM testers may have voltage transition surges, which may trigger the protection of the SGM41107A. Careful attention is required for doing such evaluations with this kind of equipment. External voltage and current limits within the conditions specified in the Absolute Maximum Ratings section of this datasheet are required.

Select Protection Parameters

Battery models from different vendors may be customized for different applications. Consult the battery vendor for protection limits for specific battery model.

Parameters for the protection circuit and of the charger circuit affecting same variables should be set for proper charge or discharge protection sequence. For example, the over-voltage threshold of the battery should be 50mV to 100mV higher than constant voltage threshold of the charger.

Cautions on parameter misalignment: If the V_{OV} is lower than the full charge voltage of the battery charger, the protection circuit cuts off the battery charge path before the battery is fully charged, and turns into the non-conductive locked-off state, if the I_{OC} is lower than the charge current, the protection circuit also turns itself into the locked-off state. In either V_{OV} or I_{OC} , the charger input should be removed and then reapplied to activate the protection circuit from the locked-off state to the conducting state. If the charger is not removed after a V_{OV} or I_{OC} event, the battery will not be charged even if the battery voltage is depleted.

REVISION HISTORY

NOTE: Page numbers for previous revisions may differ from page numbers in the current version.

Changes from Original to REV.A (APRIL 2026)	Page
Changed from product preview to production data.....	All

PACKAGE INFORMATION

PACKAGE OUTLINE DIMENSIONS

XTDFN-1x1-4L

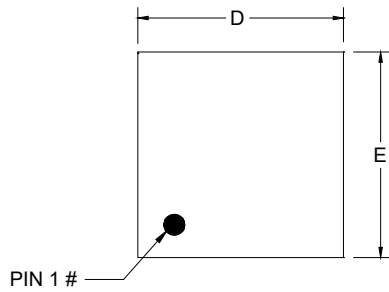

TOP VIEW

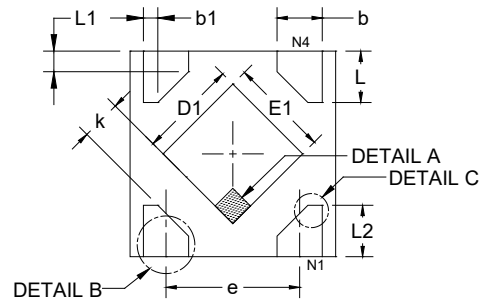

BOTTOM VIEW

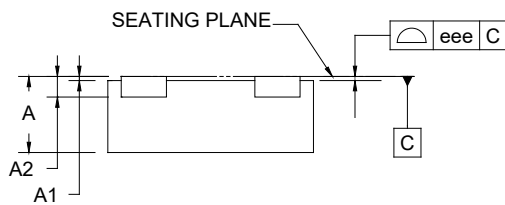

SIDE VIEW

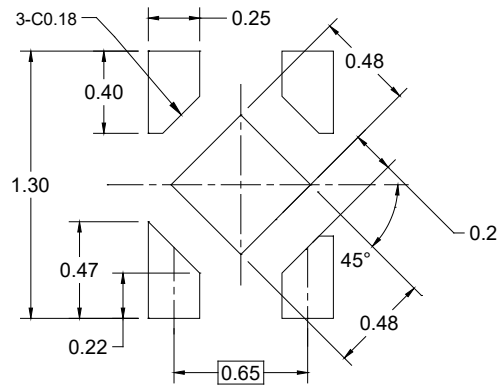

RECOMMENDED LAND PATTERN (Unit: mm)

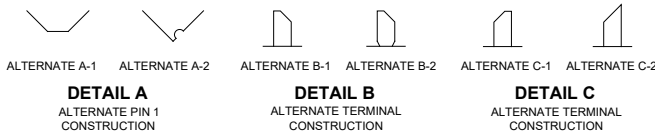

Symbol	Dimensions In Millimeters		
	MIN	NOM	MAX
A	0.340	0.370	0.400
A1	0.000	0.020	0.050
A2	0.100 REF		
b	0.170	-	0.300
b1	0.068 REF		
D	0.950	1.000	1.050
E	0.950	1.000	1.050
D1	0.430	0.480	0.530
E1	0.430	0.480	0.530
L	0.200	0.250	0.300
L1	0.093 REF		
L2	0.200	-	0.370
e	0.650 BSC		
k	0.150	-	-
eee	-	0.050	-

NOTE: This drawing is subject to change without notice.

TAPE AND REEL INFORMATION

REEL DIMENSIONS

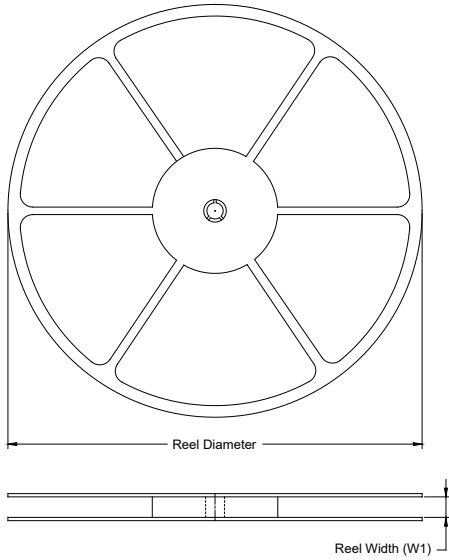

TAPE DIMENSIONS

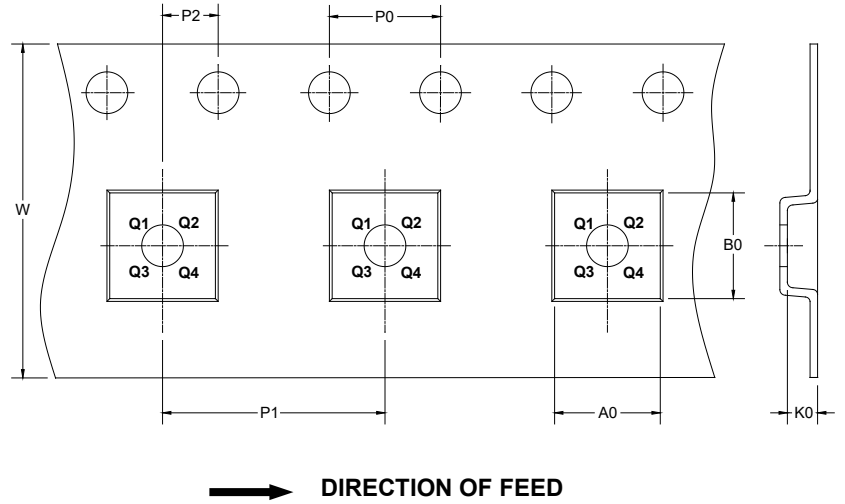

NOTE: The picture is only for reference. Please make the object as the standard.

KEY PARAMETER LIST OF TAPE AND REEL

Package Type	Reel Diameter	Reel Width W1 (mm)	A0 (mm)	B0 (mm)	K0 (mm)	P0 (mm)	P1 (mm)	P2 (mm)	W (mm)	Pin1 Quadrant
XTDFN-1×1-4L	7"	9.5	1.16	1.16	0.50	4.0	2.0	2.0	8.0	Q1

DD0001

PACKAGE INFORMATION

CARTON BOX DIMENSIONS

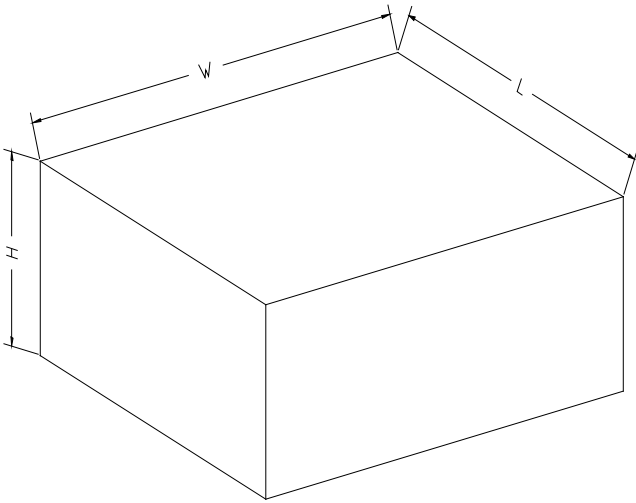

NOTE: The picture is only for reference. Please make the object as the standard.

KEY PARAMETER LIST OF CARTON BOX

Reel Type	Length (mm)	Width (mm)	Height (mm)	Pizza/Carton
7" (Option)	368	227	224	8
7"	442	410	224	18

D00002