



SGMNQ19360

60V, Power, Single N-Channel, DFN Package, MOSFET

FEATURES

- Low On-State Resistance
- Low Total Gate Charge and Capacitance Losses
- RoHS Compliant and Halogen Free

APPLICATIONS

- Power Tool
- Brushless DC Motor Control
- Hotswap/In-Rush Current Management
- DC/DC Converters
- Power Load Switch and eFuse
- SSD Power/OVP Switch
- Wireless Charging Switch

EQUIVALENT CIRCUIT

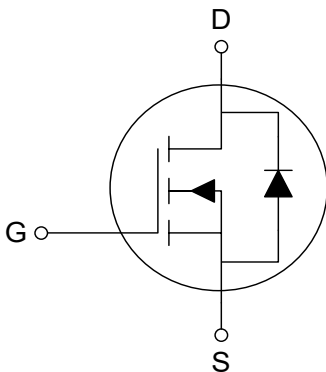

PRODUCT SUMMARY

PACKAGE	$R_{DS(on)}$ (TYP) $V_{GS} = 10V$	$R_{DS(on)}$ (MAX) $V_{GS} = 10V$	I_D (MAX) $T_C = +25^\circ C$
PDFN-5×6-8BL	15mΩ	19.5mΩ	33A
PDFN-3.3×3.3-8AL	15mΩ	19.5mΩ	30A
TDFN-2×2-6BL	15mΩ	19.5mΩ	27A

PIN CONFIGURATIONS

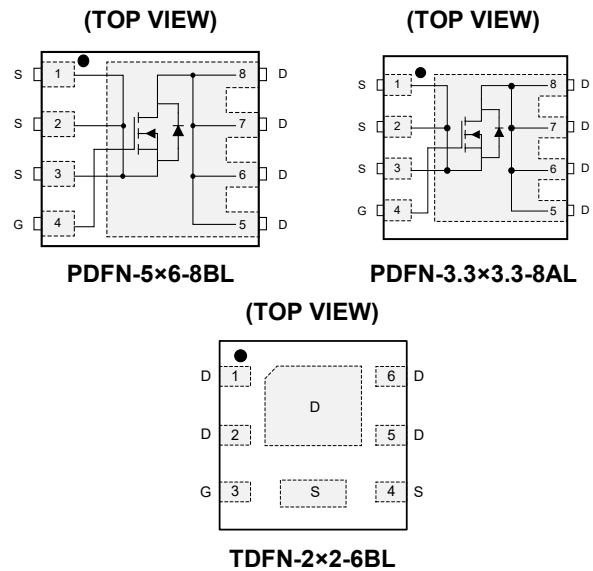

ABSOLUTE MAXIMUM RATINGS

PARAMETER	SYMBOL	VALUE	UNITS	
Drain-to-Source Voltage	V_{DS}	60	V	
Gate-to-Source Voltage	V_{GS}	± 20	V	
Drain Current ⁽¹⁾ PDFN-5×6-8BL	I_D	$T_C = +25^\circ\text{C}$	33	A
		$T_C = +100^\circ\text{C}$	21	
		$T_A = +25^\circ\text{C}$	9	
		$T_A = +70^\circ\text{C}$	7	
Drain Current ⁽¹⁾ PDFN-3.3×3.3-8AL	I_D	$T_C = +25^\circ\text{C}$	30	A
		$T_C = +100^\circ\text{C}$	19	
		$T_A = +25^\circ\text{C}$	9	
		$T_A = +70^\circ\text{C}$	7	
Drain Current ⁽¹⁾ TDFN-2×2-6BL	I_D	$T_C = +25^\circ\text{C}$	27	A
		$T_C = +100^\circ\text{C}$	17	
		$T_A = +25^\circ\text{C}$	6.9	
		$T_A = +70^\circ\text{C}$	5	
Drain Current (Pulse) ⁽²⁾ PDFN-5×6-8BL	I_{DM}	80	A	
Drain Current (Pulse) ⁽²⁾ PDFN-3.3×3.3-8AL	I_{DM}	72	A	
Drain Current (Pulse) ⁽²⁾ TDFN-2×2-6BL	I_{DM}	60	A	

PARAMETER	SYMBOL	VALUE	UNITS	
Total Dissipation PDFN-5×6-8BL	P_D	$T_C = +25^\circ\text{C}$	37	W
		$T_C = +100^\circ\text{C}$	15	
		$T_A = +25^\circ\text{C}$	2.5	
		$T_A = +70^\circ\text{C}$	1.6	
Total Dissipation PDFN-3.3×3.3-8AL	P_D	$T_C = +25^\circ\text{C}$	32	W
		$T_C = +100^\circ\text{C}$	13	
		$T_A = +25^\circ\text{C}$	2.2	
		$T_A = +70^\circ\text{C}$	1.4	
Total Dissipation TDFN-2×2-6BL	P_D	$T_C = +25^\circ\text{C}$	31	W
		$T_C = +100^\circ\text{C}$	12	
		$T_A = +25^\circ\text{C}$	1.9	
		$T_A = +70^\circ\text{C}$	1.2	
Avalanche Current ⁽³⁾	I_{AS}	26.1	A	
Avalanche Energy ⁽³⁾	E_{AS}	34.06	mJ	
Junction Temperature	T_J	+150	$^\circ\text{C}$	
Storage Temperature Range	T_{STG}	-55 to +150	$^\circ\text{C}$	
Lead Temperature (Soldering, 10s)		+260	$^\circ\text{C}$	

Stresses beyond those listed in Absolute Maximum Ratings may cause permanent damage to the device. Exposure to absolute maximum rating conditions for extended periods may affect reliability.

NOTES:

1. The current will be limited by package, PCB, thermal design and operating temperature.
2. $t_{PULSE} < 10\mu\text{s}$.
3. Parts are 100% tested at $V_{GS} = 10\text{V}$, $I_L = 18.4\text{A}$, and $E_{AS} = 17.1\text{mJ}$.

PACKAGE/ORDERING INFORMATION

MODEL	PACKAGE DESCRIPTION	SPECIFIED TEMPERATURE RANGE	ORDERING NUMBER	PACKAGE MARKING	PACKING OPTION
SGMNQ19360	PDFN-5×6-8BL	-55°C to +150°C	SGMNQ19360TPDA8G/TR	SGM1TN TPDA8 XXXXX	Tape and Reel, 4000
	PDFN-3.3×3.3-8AL	-55°C to +150°C	SGMNQ19360TPDB8G/TR	SGM1J7 TPDB8 XXXXX	Tape and Reel, 5000
	TDFN-2×2-6BL	-55°C to +150°C	SGMNQ19360TTEN6G/TR	2NG XXXX	Tape and Reel, 3000

MARKING INFORMATION

NOTE: XXXXX = Date Code, Trace Code and Vendor Code.

PDFN-5×6-8BL and PDFN-3.3×3.3-8AL

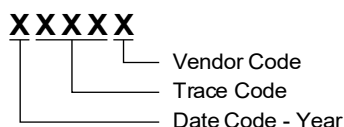

NOTE: XXXX = Date Code, Trace Code and Vendor Code.

TDFN-2×2-6BL

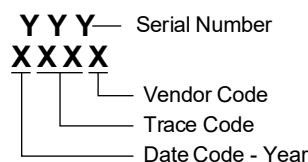

Green (RoHS & HSF): SG Micro Corp defines "Green" to mean Pb-Free (RoHS compatible) and free of halogen substances. If you have additional comments or questions, please contact your SGMICRO representative directly.

DISCLAIMER

SG Micro Corp reserves the right to make any change in circuit design, or specifications without prior notice.

THERMAL RESISTANCE

PARAMETER		SYMBOL	TYP	UNITS
Junction-to-Case Thermal Resistance	PDFN-5×6-8BL	R _{θJC}	3.3	°C/W
	PDFN-3.3×3.3-8AL		3.8	
	TDFN-2×2-6BL		4	
Junction-to-Ambient Thermal Resistance ⁽¹⁾	PDFN-5×6-8BL	R _{θJA}	49	°C/W
	PDFN-3.3×3.3-8AL		56	
	TDFN-2×2-6BL		65	

NOTE: 1. R_{θJA} is determined with the device mounted on one square inch of copper pad, 2oz copper on FR4 board.

ELECTRICAL CHARACTERISTICS(T_A = +25°C, unless otherwise noted.)

PARAMETER	SYMBOL	CONDITIONS	MIN	TYP	MAX	UNITS	
Static OFF Characteristics							
Drain-to-Source Breakdown Voltage	V _{BR_DSS}	V _{GS} = 0V, I _D = 250μA	60			V	
Zero Gate Voltage Drain Current	I _{DSS}	V _{GS} = 0V, V _{DS} = 48V			1	μA	
Gate-to-Source Leakage Current	I _{GSS}	V _{GS} = ±20V, V _{DS} = 0V			±100	nA	
Static ON Characteristics							
Gate-to-Source Threshold Voltage	V _{GS_TH}	V _{GS} = V _{DS} , I _D = 250μA	1.2	1.75	2.5	V	
Drain-to-Source On-State Resistance	R _{DS(on)}	V _{GS} = 10V, I _D = 10A		15	19.5	mΩ	
		V _{GS} = 4.5V, I _D = 10A	PDFN-5×6-8BL and PDFN-3.3×3.3-8AL		22		30
			TDFN-2×2-6BL		23		35
Forward Transconductance	g _{FS}	V _{DS} = 5V, I _D = 10A		13		S	
Gate Resistance	R _G	V _{GS} = 0V, V _{DS} = 0V, f = 1MHz		1		Ω	
Diode Characteristics							
Diode Forward Voltage	V _{F_SD}	V _{GS} = 0V, I _S = 1A		0.7	1.2	V	
Reverse Recovery Time	t _{RR}	V _{GS} = 0V, I _S = 10A, di/dt = 100A/μs		16		ns	
Reverse Recovery Charge	Q _{RR}			6		nC	
Dynamic Characteristics							
Input Capacitance	C _{ISS}	V _{GS} = 0V, V _{DS} = 30V, f = 1MHz		568		pF	
Output Capacitance	C _{OSS}			141			
Reverse Transfer Capacitance	C _{RSS}			16			
Total Gate Charge	Q _G	V _{DS} = 45V, I _D = 10A	V _{GS} = 10V		13.3	nC	
			V _{GS} = 4.5V		7.1		
Gate-to-Source Charge	Q _{GS}	V _{GS} = 4.5V, V _{DS} = 45V, I _D = 10A		2.2			
Gate-to-Drain Charge	Q _{GD}			3.6			
Switch Characteristics							
Turn-On Delay Time	t _{D_ON}	V _{GS} = 10V, V _{DS} = 45V, I _D = 10A, R _G = 3Ω		1.3		ns	
Rise Time	t _R			16.6			
Turn-Off Delay Time	t _{D_OFF}			9.1			
Fall Time	t _F			2.8			

TYPICAL PERFORMANCE CHARACTERISTICS

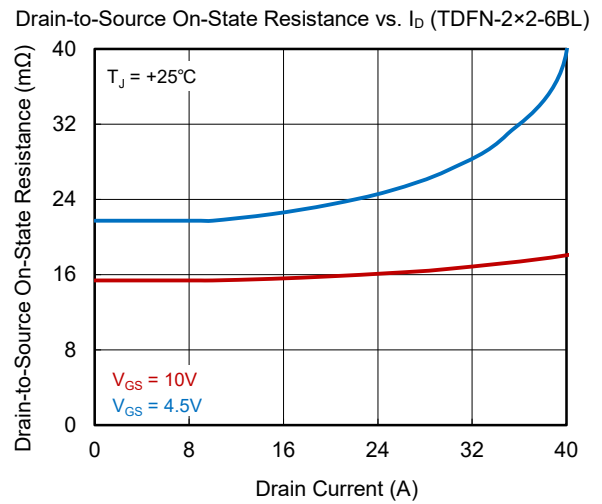
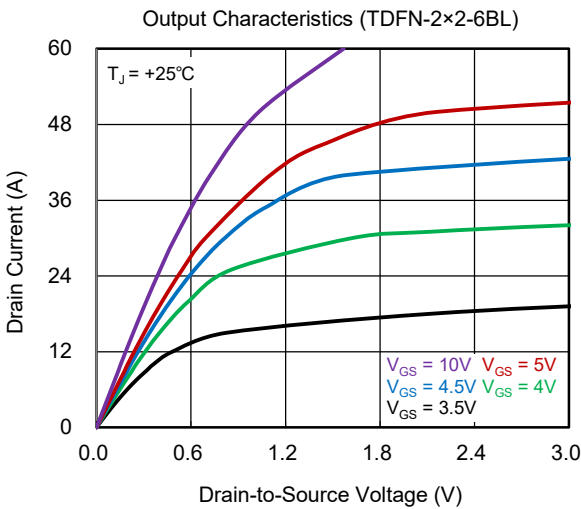
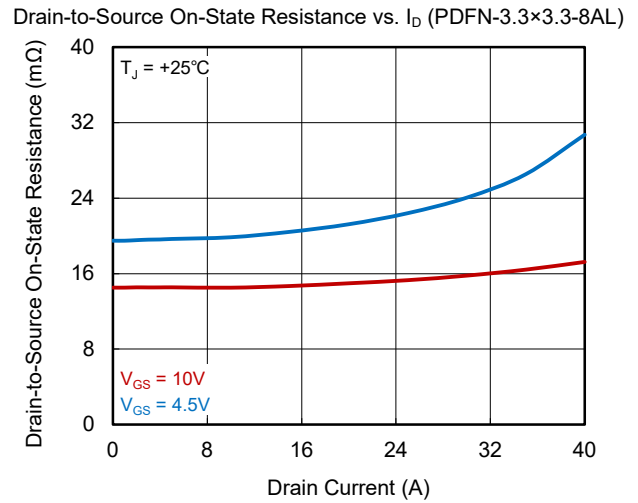
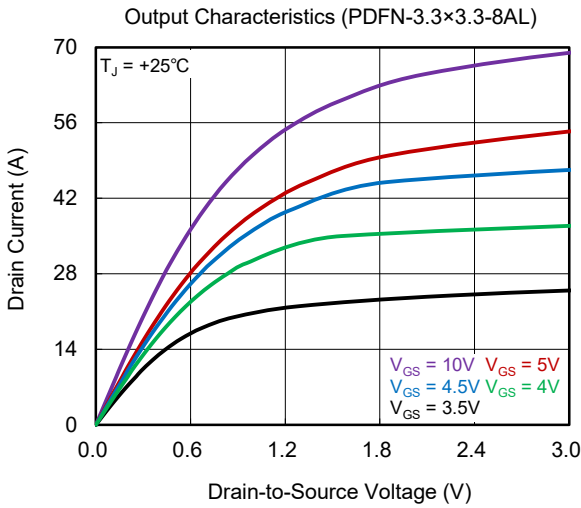
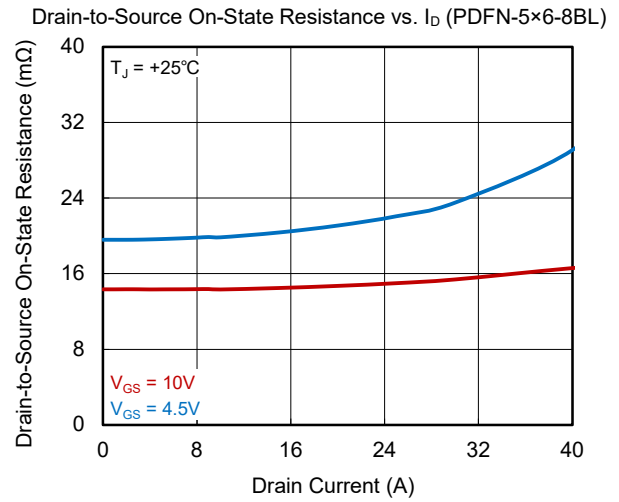
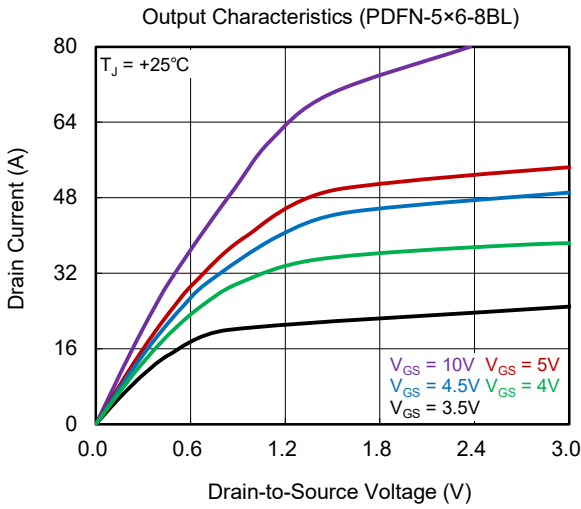

TYPICAL PERFORMANCE CHARACTERISTICS (continued)

Drain-to-Source On-State Resistance vs. V_{GS} (PDFN-5×6-8BL)

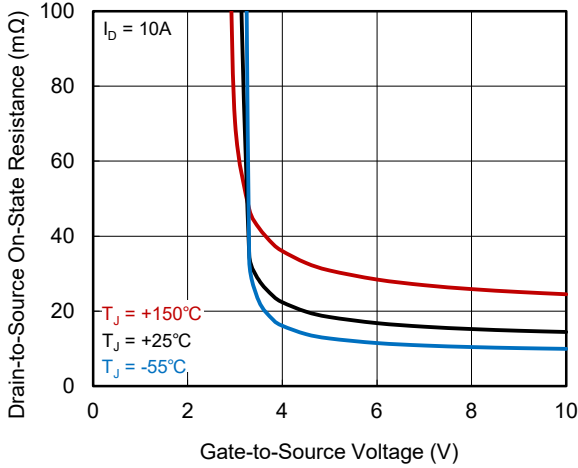

Diode Forward (PDFN-5×6-8BL)

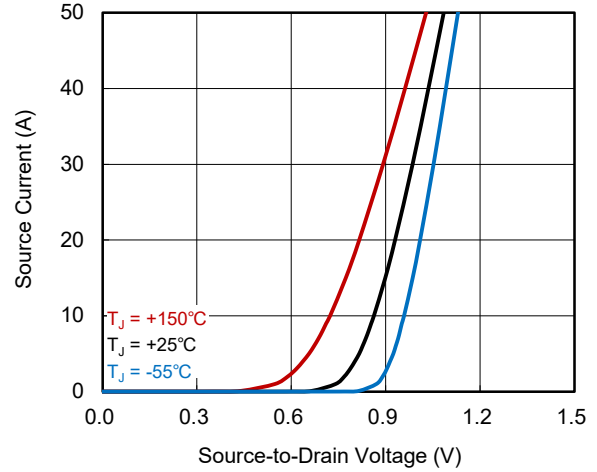

Drain-to-Source On-State Resistance vs. V_{GS} (PDFN-3.3×3.3-8AL)

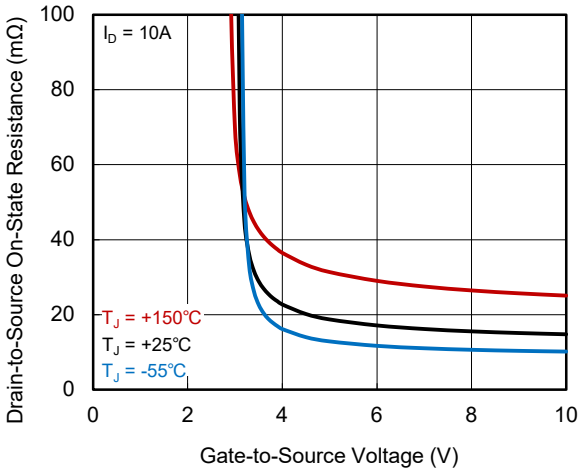

Diode Forward (PDFN-3.3×3.3-8AL)

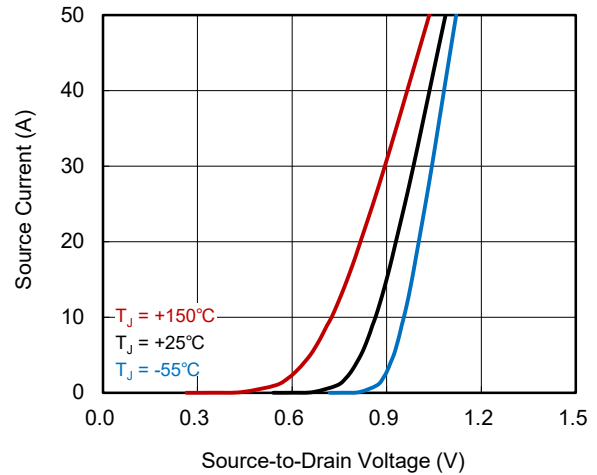

Drain-to-Source On-State Resistance vs. V_{GS} (TDFN-2×2-6BL)

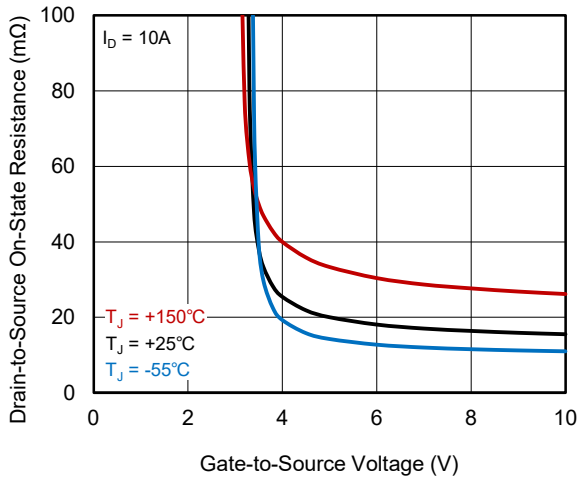

Diode Forward (TDFN-2×2-6BL)

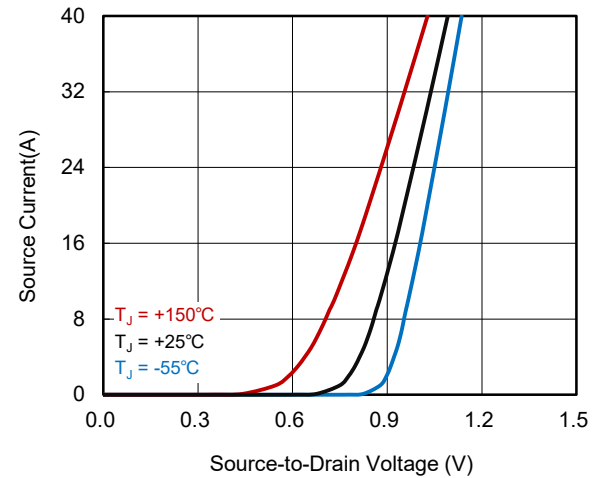

TYPICAL PERFORMANCE CHARACTERISTICS (continued)

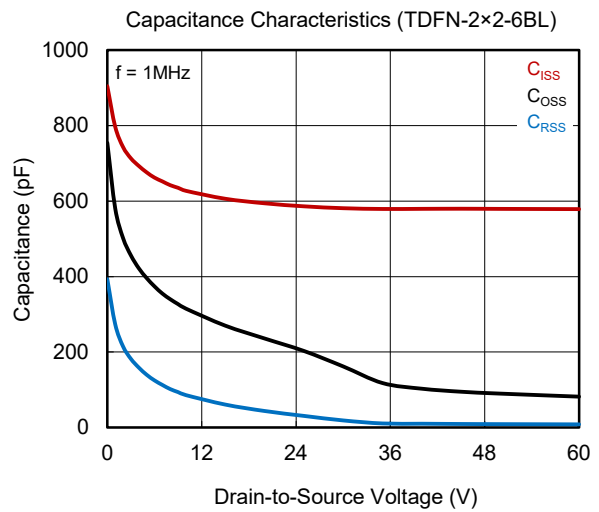
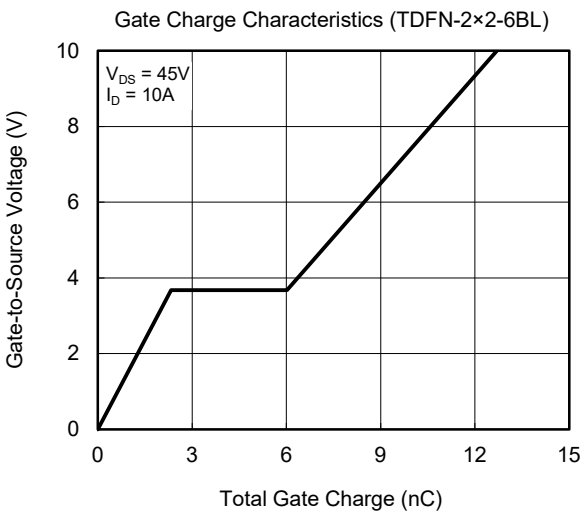
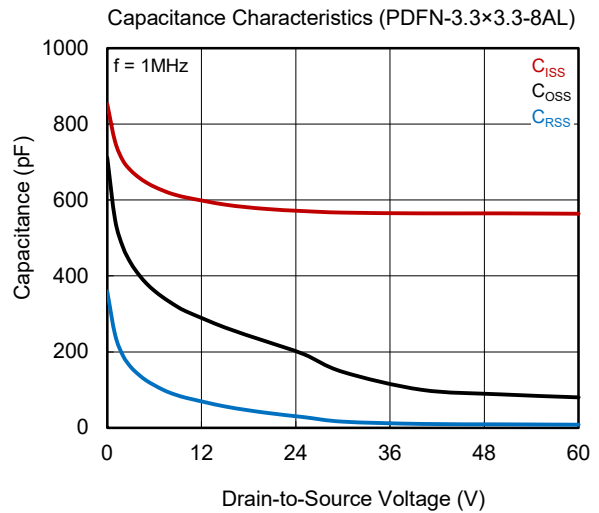
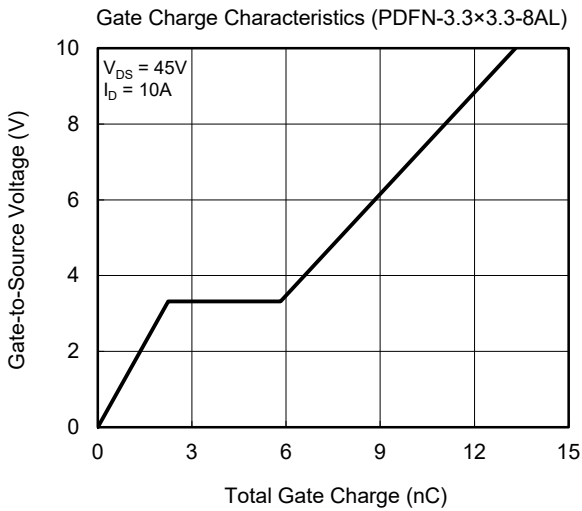
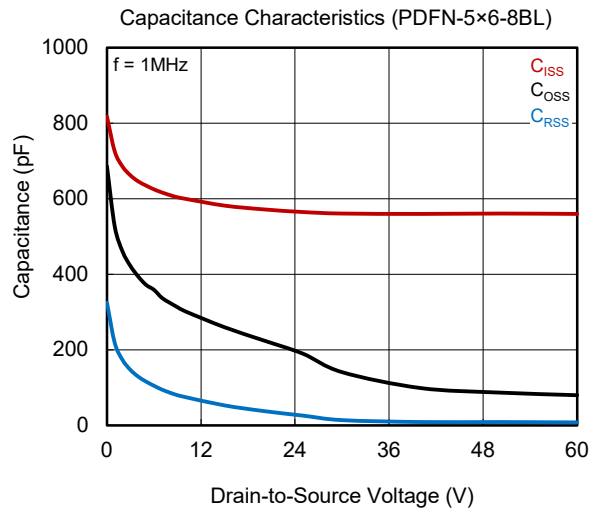
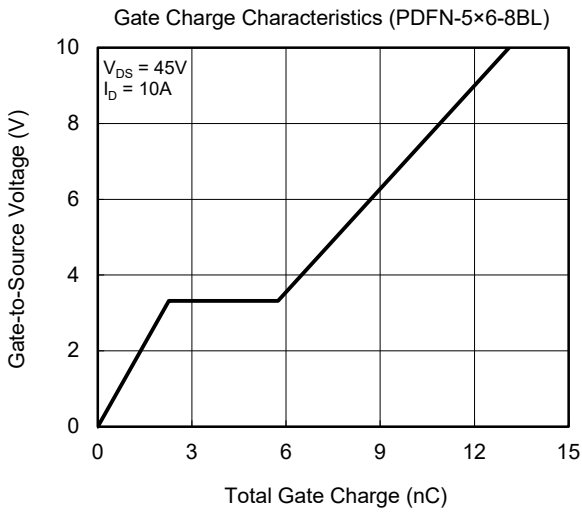

TYPICAL PERFORMANCE CHARACTERISTICS (continued)

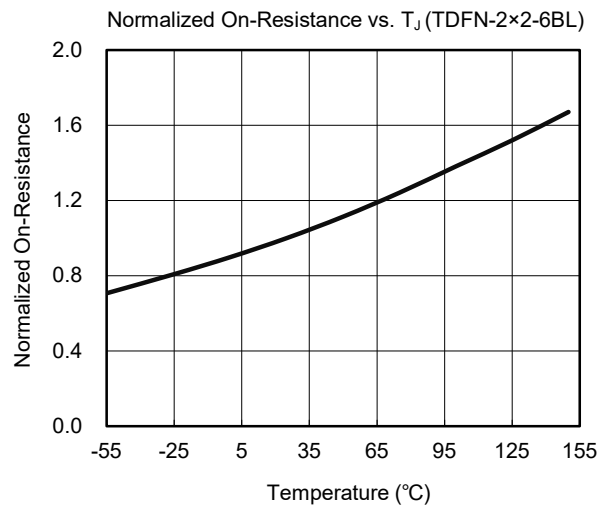
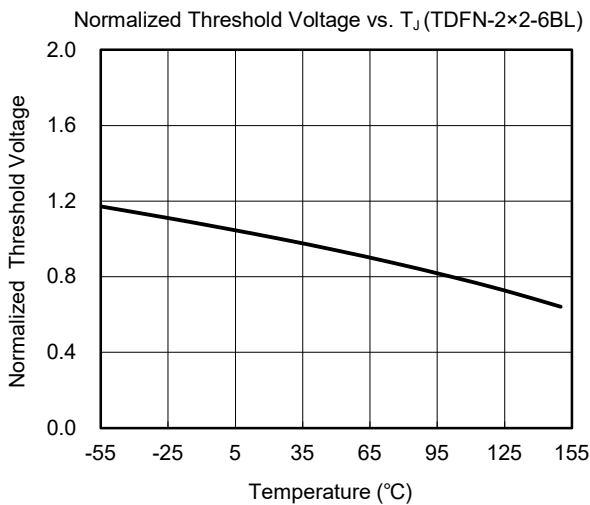
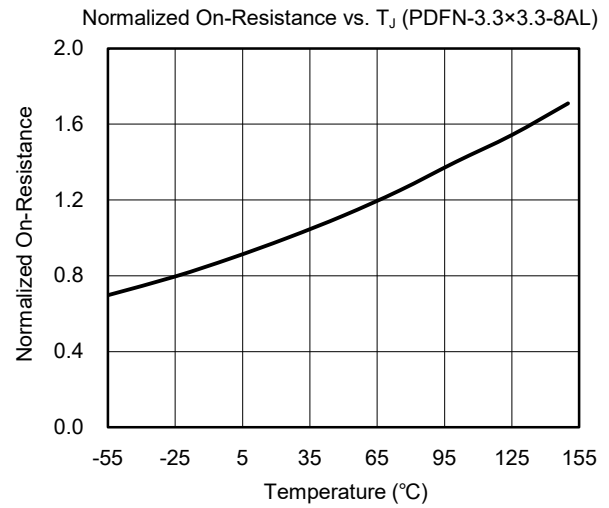
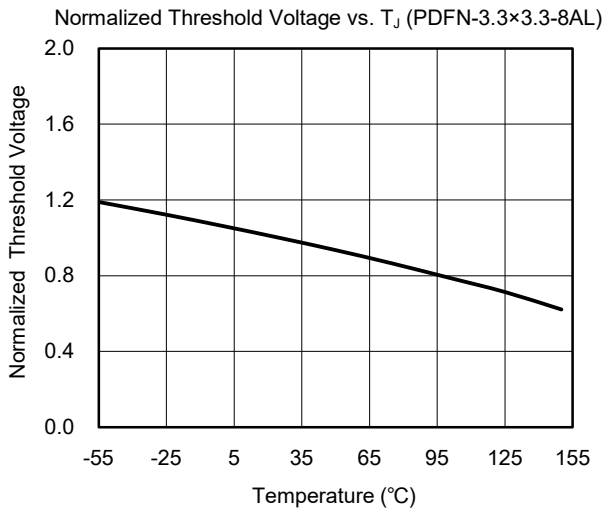
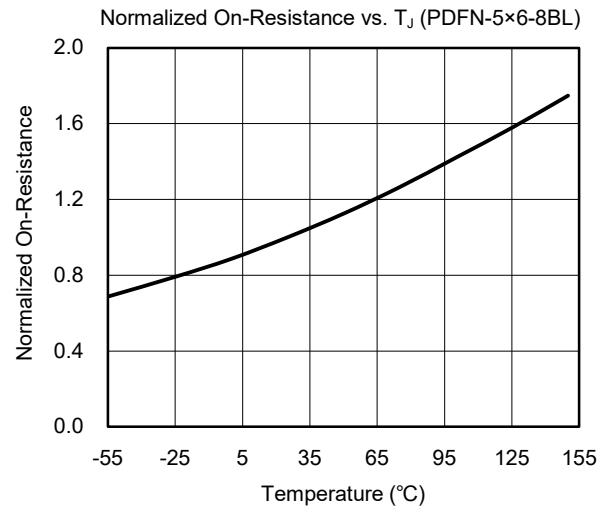
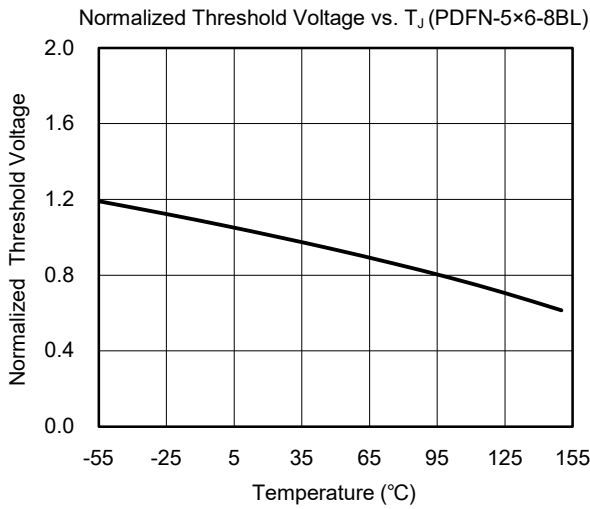

TYPICAL PERFORMANCE CHARACTERISTICS (continued)

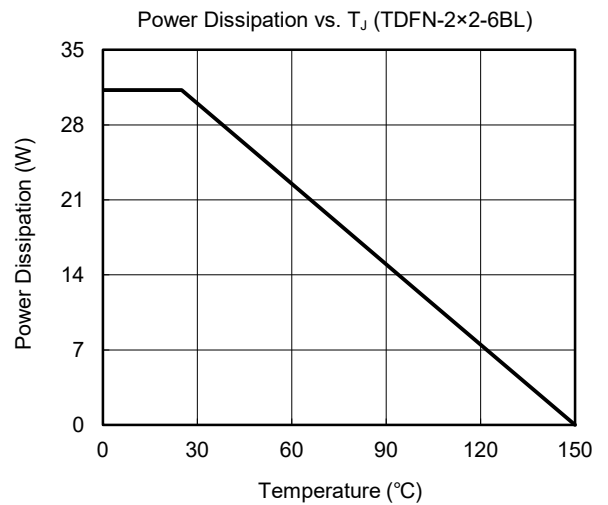
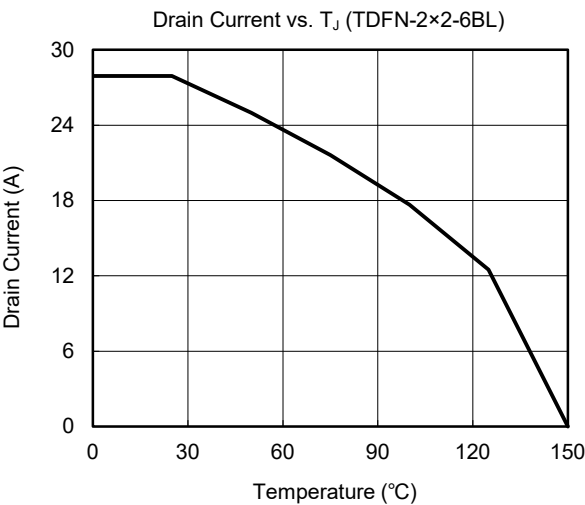
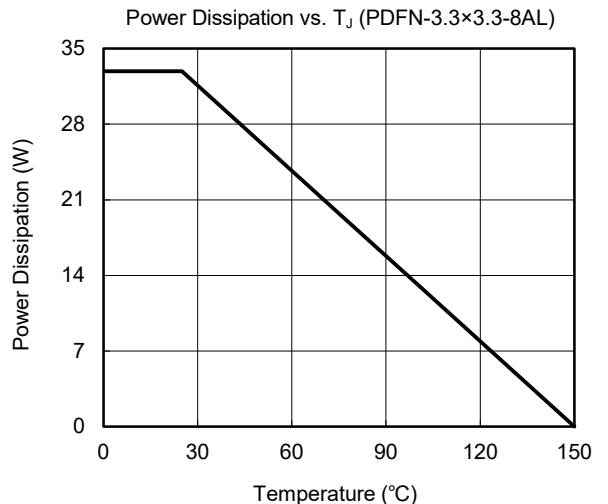
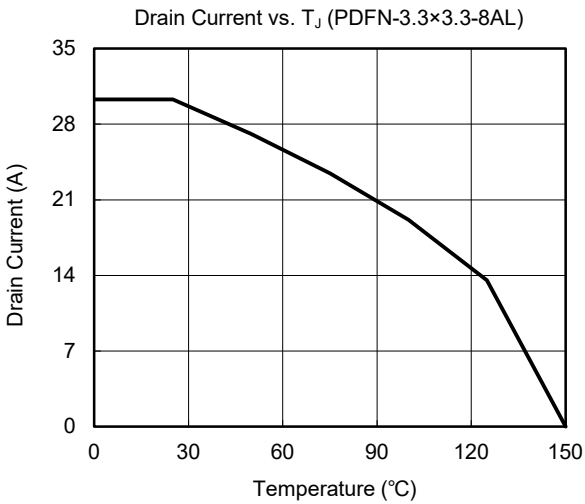
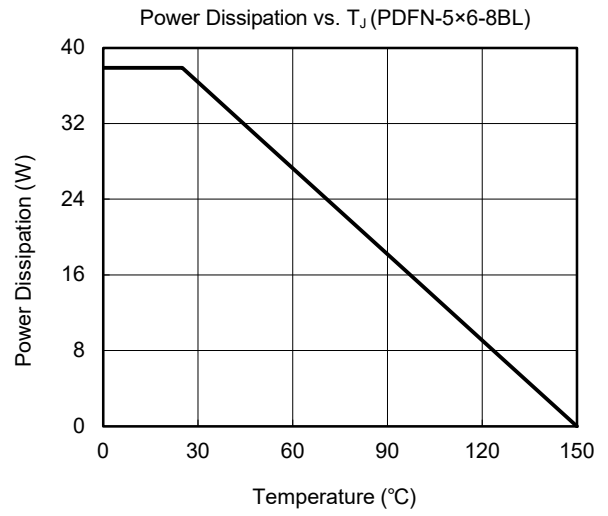
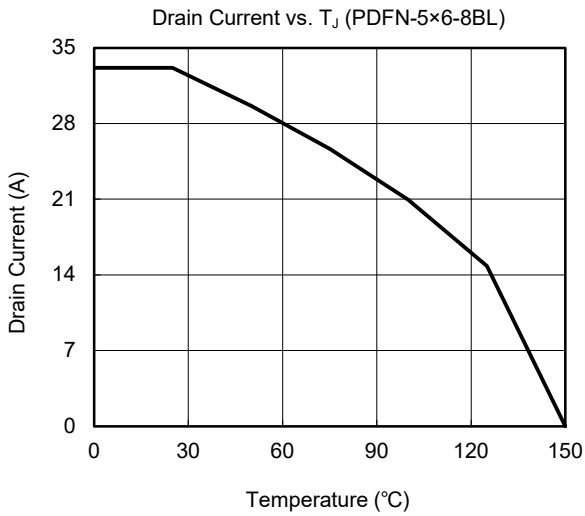

TYPICAL PERFORMANCE CHARACTERISTICS (continued)

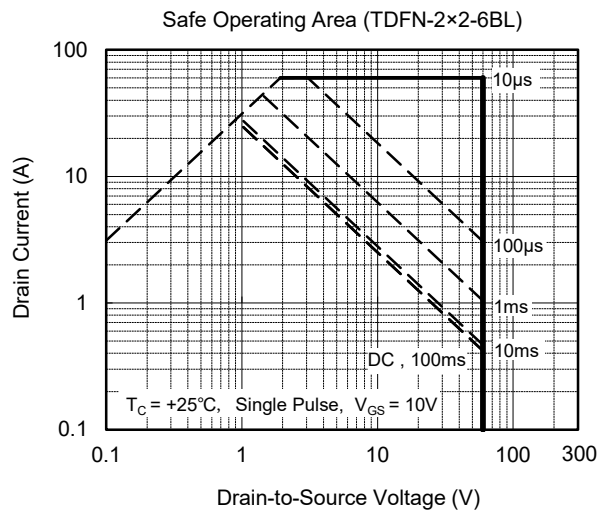
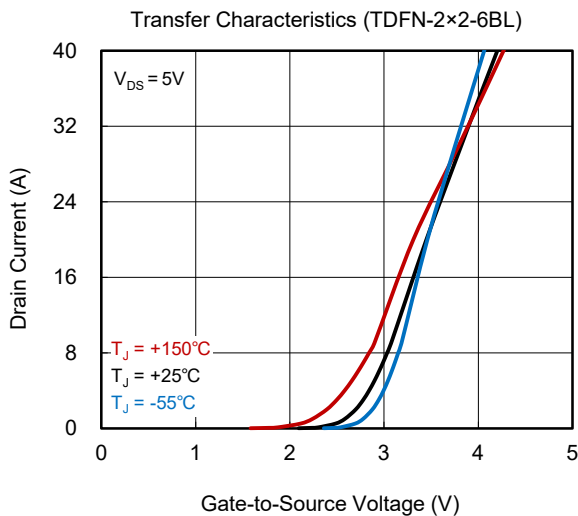
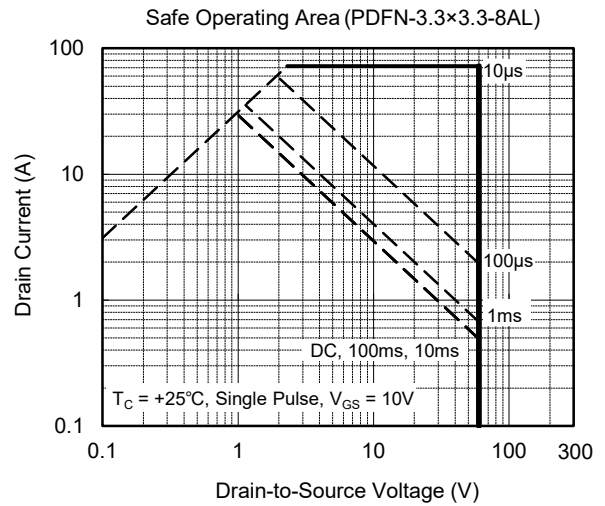
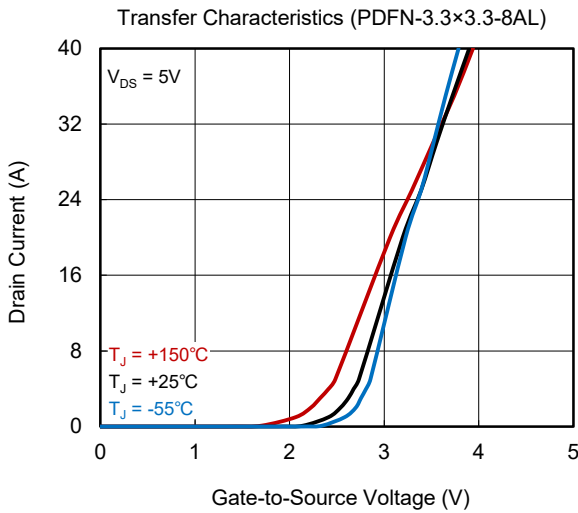
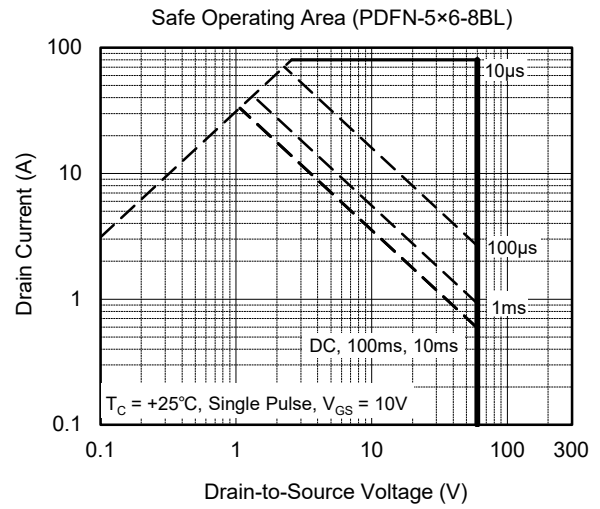
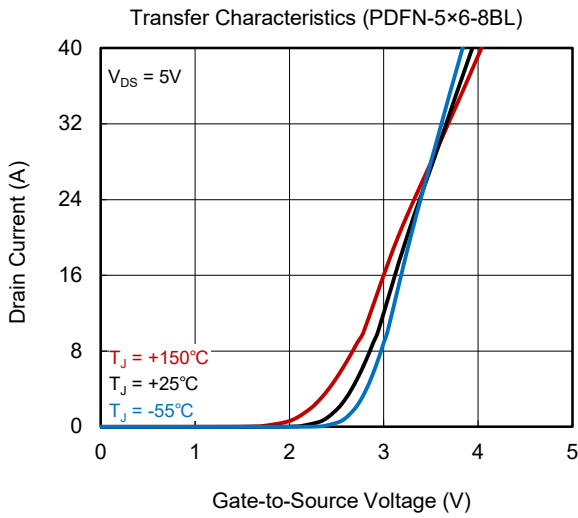

TYPICAL PERFORMANCE CHARACTERISTICS (continued)

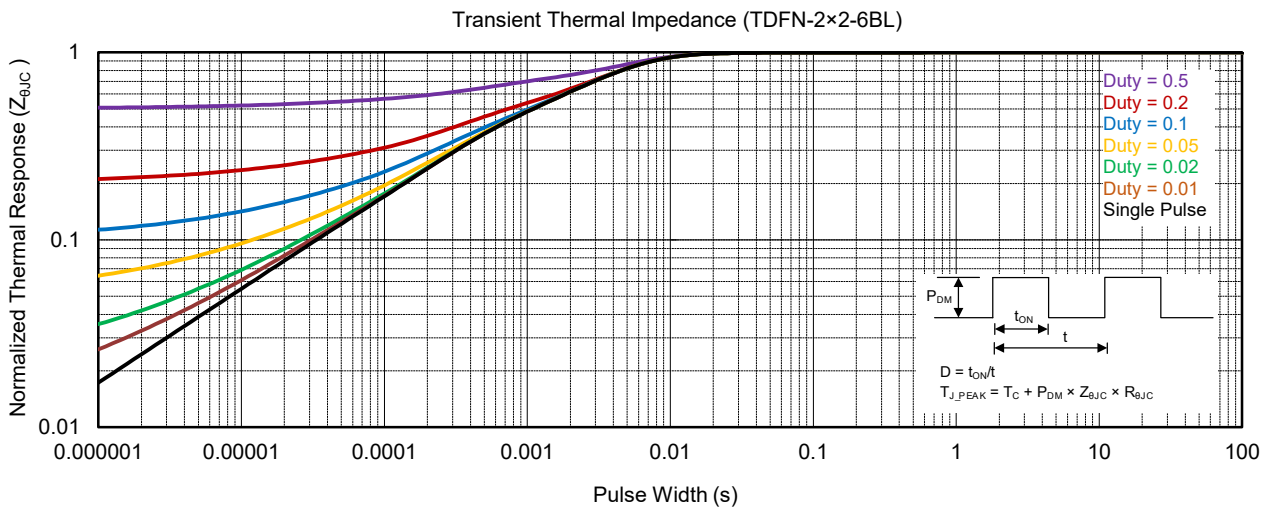
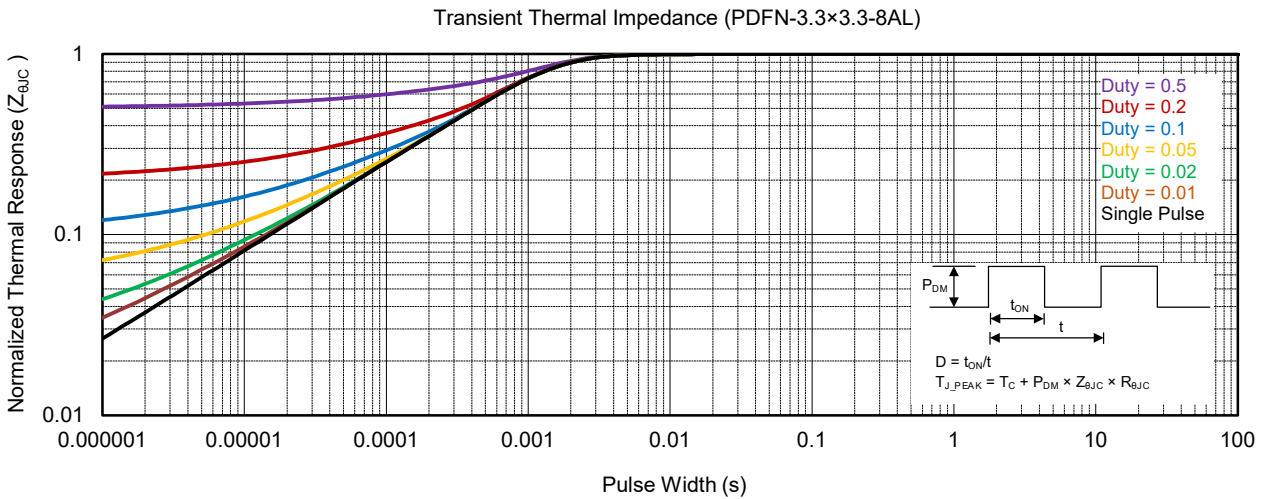
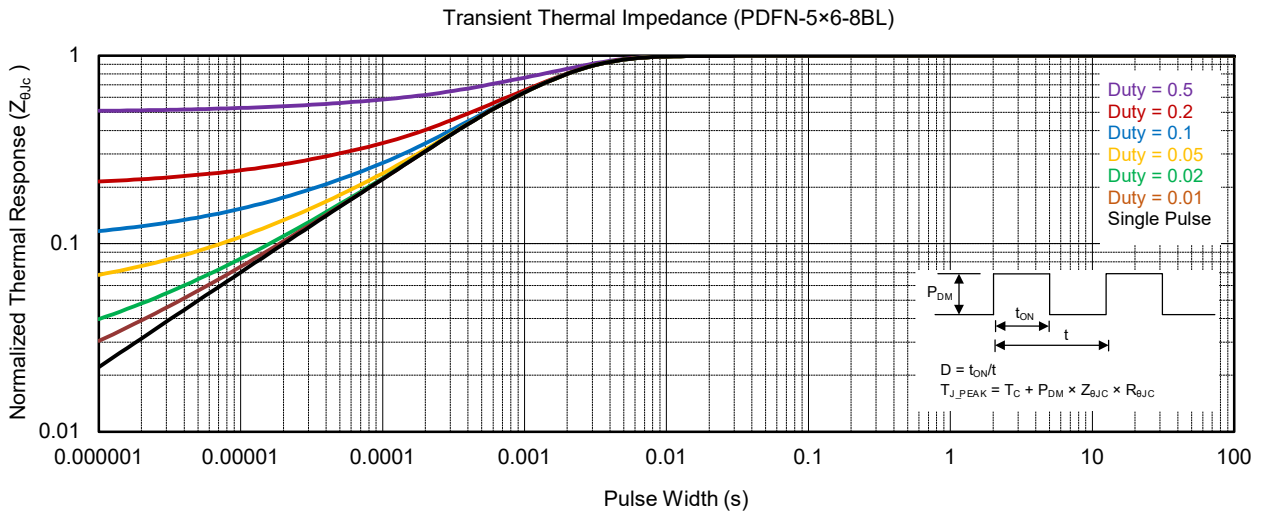

REVISION HISTORY

NOTE: Page numbers for previous revisions may differ from page numbers in the current version.

APRIL 2026 – REV.A.1 to REV.A.2	Page
Updated TDFN-2×2-6BL package	All

FEBRUARY 2026 – REV.A to REV.A.1	Page
Updated PDFN-5×6-8BL package	All

Changes from Original to REV.A (SEPTEMBER 2025)	Page
Changed from product preview to production data.....	All

PACKAGE OUTLINE DIMENSIONS

PDFN-5×6-8BL

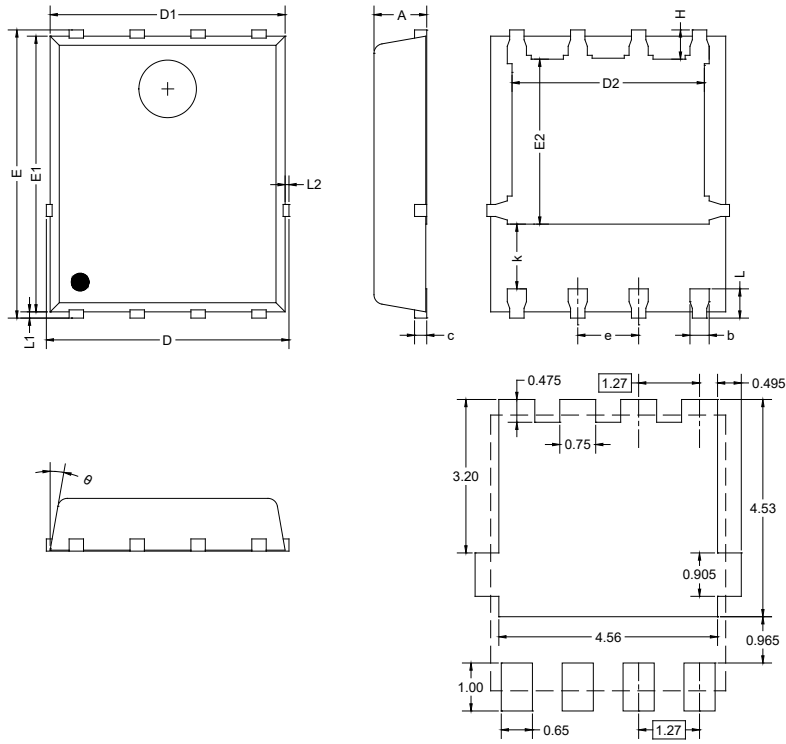

RECOMMENDED LAND PATTERN (Unit: mm)

Symbol	Dimensions In Millimeters		
	MIN	NOM	MAX
A	1.000	1.100	1.200
b	0.300	0.400	0.500
c	0.150	0.250	0.350
D	4.800	-	5.400
D1	4.800	4.900	5.000
D2	3.910	4.010	4.310
E	5.900	6.000	6.250
E1	5.650	5.750	5.850
E2	3.300	3.440	3.540
e	1.270 BSC		
H	0.350	0.610	0.710
k	1.100	-	-
L	0.380	0.610	0.710
L1	0.050	0.130	0.250
L2	-	-	0.220
θ	8°	10°	12°

NOTE: This drawing is subject to change without notice.

PACKAGE OUTLINE DIMENSIONS

PDFN-3.3×3.3-8AL

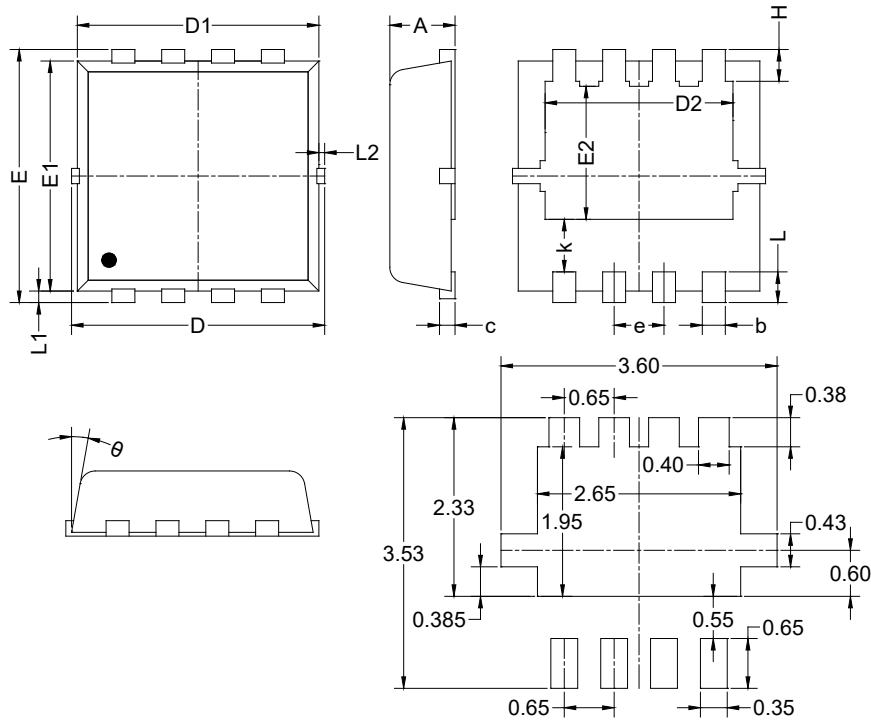

RECOMMENDED LAND PATTERN (Unit: mm)

Symbol	Dimensions in Millimeters		
	MIN	NOM	MAX
A	0.700	0.800	0.900
b	0.250	0.300	0.350
c	0.140	0.150	0.200
D	3.100	3.300	3.500
D1	3.050	3.150	3.250
D2	2.350	2.450	2.550
E	3.100	3.300	3.500
E1	2.900	3.000	3.100
E2	1.640	1.740	1.840
e	0.650 BSC		
H	0.320	0.420	0.520
k	0.590	0.690	0.790
L	0.250	0.400	0.550
L1	0.100	0.150	0.200
L2	-	-	0.150
θ	8°	10°	12°

NOTE: This drawing is subject to change without notice.

PACKAGE OUTLINE DIMENSIONS

TDFN-2x2-6BL

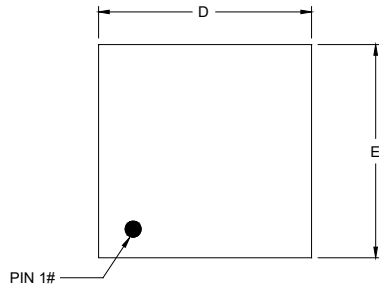

TOP VIEW

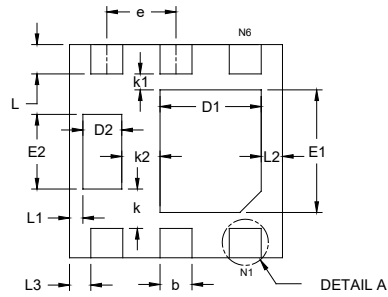

BOTTOM VIEW

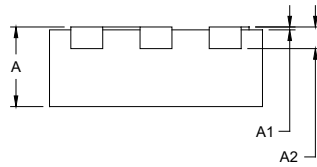

SIDE VIEW

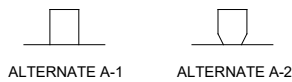

DETAIL A

ALTERNATE TERMINAL CONSTRUCTION

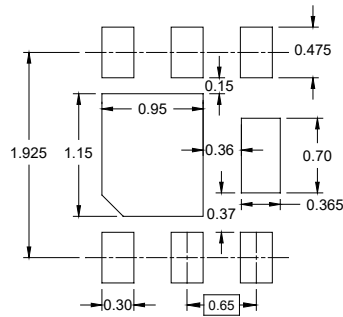

RECOMMENDED LAND PATTERN (Unit: mm)

Symbol	Dimensions In Millimeters		
	MIN	NOM	MAX
A	0.700	0.750	0.800
A1	0.000	0.020	0.050
A2	0.200 REF		
b	0.250	0.300	0.350
D	1.900	2.000	2.100
E	1.900	2.000	2.100
D1	0.850	0.950	1.050
E1	1.050	1.150	1.250
D2	0.315	0.365	0.415
E2	0.650	0.700	0.750
e	0.650 BSC		
k	0.370 REF		
k1	0.150 REF		
k2	0.360 REF		
L	0.225	0.275	0.325
L1	0.125 REF		
L2	0.200 REF		
L3	0.200 REF		

NOTE: This drawing is subject to change without notice.

PACKAGE INFORMATION

TAPE AND REEL INFORMATION

REEL DIMENSIONS

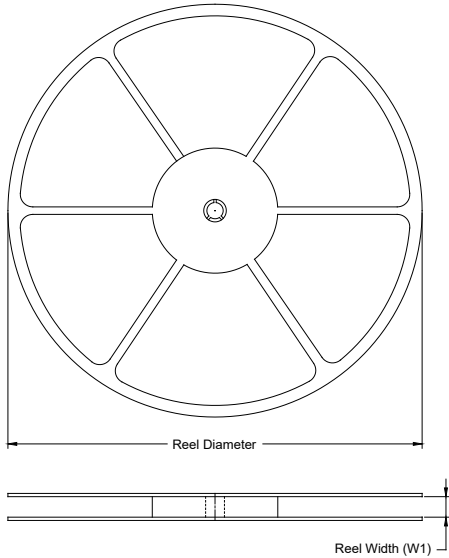

TAPE DIMENSIONS

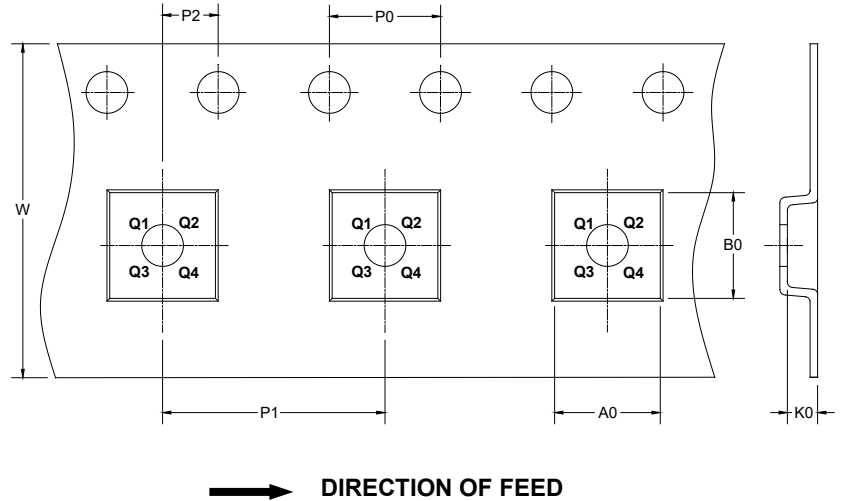

NOTE: The picture is only for reference. Please make the object as the standard.

KEY PARAMETER LIST OF TAPE AND REEL

Package Type	Reel Diameter	Reel Width W1 (mm)	A0 (mm)	B0 (mm)	K0 (mm)	P0 (mm)	P1 (mm)	P2 (mm)	W (mm)	Pin1 Quadrant
PDFN-5×6-8BL	13"	12.4	6.45	5.30	1.40	4.0	8.0	2.0	12.0	Q1
PDFN-3.3×3.3-8AL	13"	12.4	3.60	3.60	1.10	4.0	8.0	2.0	12.0	Q1
TDFN-2×2-6BL	7"	9.5	2.30	2.30	1.00	4.0	4.0	2.0	8.0	Q1

DD0001

PACKAGE INFORMATION

CARTON BOX DIMENSIONS

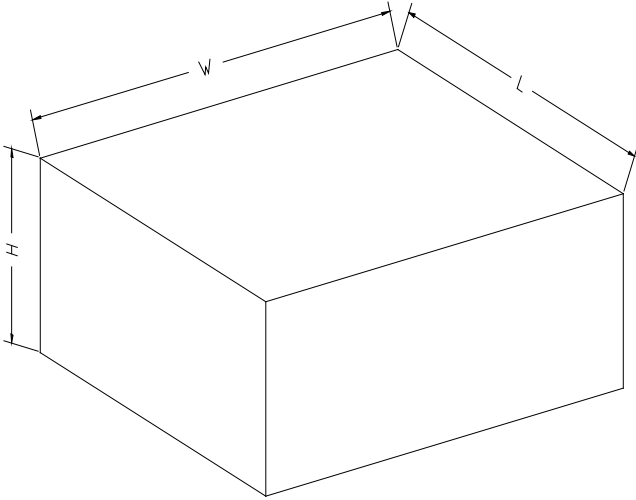

NOTE: The picture is only for reference. Please make the object as the standard.

KEY PARAMETER LIST OF CARTON BOX

Reel Type	Length (mm)	Width (mm)	Height (mm)	Pizza/Carton
7" (Option)	368	227	224	8
7"	442	410	224	18
13"	386	280	370	5

DD0002