

GENERAL DESCRIPTION

The SGM2821 is a high efficiency, high-performance, Class-D audio power amplifier with dual mode of Automatic Level Control (ALC). It operates from 2.5V to 5.5V supply voltage. When powered with 5V supply voltage, it is capable of delivering a continuous average output of 2.4W into 4Ω load with 1% THD+N.

As a Class-D audio amplifier, the SGM2821 features up to 88% efficiency and 72dB PSRR at 217Hz which make the device ideal for battery-powered high-quality audio applications.

A key benefit of the SGM2821 over typical Class-D audio power amplifiers is that it generates much less EMI emissions, thus greatly simplifying the system design for portable applications. The device also includes the over-current and short-circuit protections with auto-recovery, which ensures the device can be operated safely and reliably without the need for system interaction.

APPLICATIONS

- Mobile Phones
- Portable Navigation Devices
- Multimedia Internet Devices
- Portable Speakers

TYPICAL APPLICATION

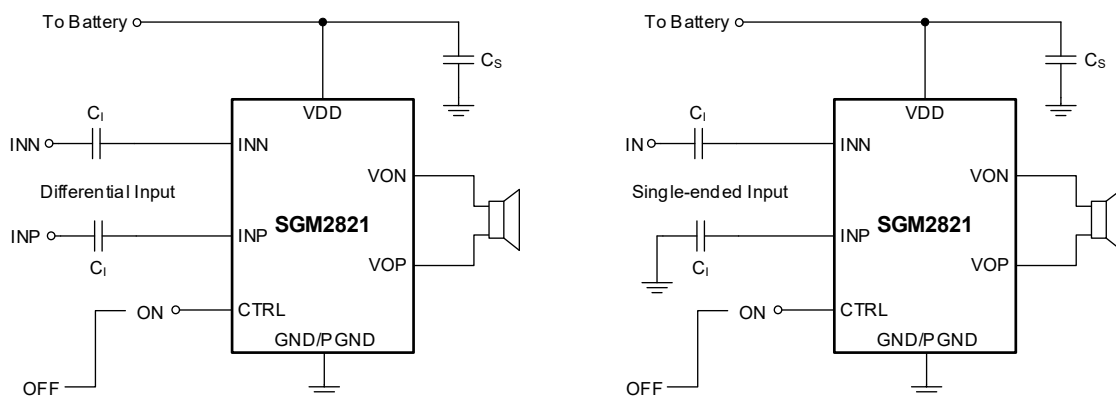

Figure 1. Typical Application Circuits

FEATURES

- Filterless Class-D Operation
- High Efficiency up to 88%
- Automatic Level Control to Eliminate Output Clipping
- Output Power at 5V Supply (ALC-OFF)
 - ◆ 3.0W (4Ω Load, 10% THD+N)
 - ◆ 2.4W (4Ω Load, 1% THD+N)
 - ◆ 1.7W (8Ω Load, 10% THD+N)
 - ◆ 1.4W (8Ω Load, 1% THD+N)
- Low THD+N: 0.05% ($V_{DD} = 3.6V$, $f = 1kHz$, $R_L = 8\Omega$, $P_O = 0.5W$)
- ALC Range: 13dB
- Low Quiescent Current: 2.6mA at $V_{DD} = 3.6V$
- Low Shutdown Current: 0.1μA (TYP)
- High PSRR: 72dB at 217Hz
- No Bypass Capacitor Required for the Common-Mode Bias
- Under-Voltage Lockout
- Auto-Recovering Over-Current and Short-Circuit Protections
- Thermal Overload Protection
- Low EMI Design
- Available in a Green UTQFN-1.5×1.5-9L Package

PACKAGE/ORDERING INFORMATION

MODEL	PACKAGE DESCRIPTION	SPECIFIED TEMPERATURE RANGE	ORDERING NUMBER	PACKAGE MARKING	PACKING OPTION
SGM2821	UTQFN-1.5×1.5-9L	-40°C to +85°C	SGM2821YUSN9G/TR	087 XXX	Tape and Reel, 3000

MARKING INFORMATION

NOTE: XXX = Date Code and Trace Code.

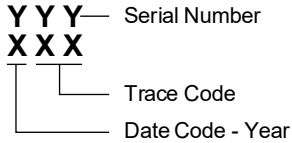

Green (RoHS & HSF): SG Micro Corp defines "Green" to mean Pb-Free (RoHS compatible) and free of halogen substances. If you have additional comments or questions, please contact your SGMICRO representative directly.

ABSOLUTE MAXIMUM RATINGS

- Supply Voltage..... -0.3V to 6V
- All Other Pins.....-0.3V to $V_{DD} + 0.3V$
- Package Thermal Resistance
- UTQFN-1.5×1.5-9L, θ_{JA} 128°C/W
- Junction Temperature.....+150°C
- Storage Temperature Range -65°C to +150°C
- Lead Temperature (Soldering, 10s).....+260°C
- ESD Susceptibility
- HBM.....4000V
- CDM 1000V

RECOMMENDED OPERATING CONDITIONS

- Supply Voltage, V_{DD}2.5V to 5.5V
- Minimum Load Resistance, R_{LOAD} , $V_{DD} < 4.6V$ 3.2Ω
- Minimum Load Resistance, R_{LOAD} , $V_{DD} \geq 4.6V$ 3.6Ω
- Operating Ambient Temperature, T_A -40°C to +85°C

OVERSTRESS CAUTION

Stresses beyond those listed in Absolute Maximum Ratings may cause permanent damage to the device. Exposure to absolute maximum rating conditions for extended periods may affect reliability. Functional operation of the device at any conditions beyond those indicated in the Recommended Operating Conditions section is not implied.

ESD SENSITIVITY CAUTION

This integrated circuit can be damaged if ESD protections are not considered carefully. SGMICRO recommends that all integrated circuits be handled with appropriate precautions. Failure to observe proper handling and installation procedures can cause damage. ESD damage can range from subtle performance degradation to complete device failure. Precision integrated circuits may be more susceptible to damage because even small parametric changes could cause the device not to meet the published specifications.

DISCLAIMER

SG Micro Corp reserves the right to make any change in circuit design, or specifications without prior notice.

PIN CONFIGURATION

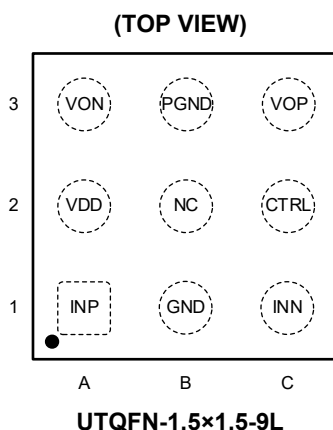

PIN DESCRIPTION

PIN	NAME	DESCRIPTION
A1	INP	Positive Audio Input Terminal.
A2	VDD	Power Supply.
A3	VON	Negative BTL Audio Output Terminal.
B1	GND	Ground.
B2	NC	No Internal Connection.
B3	PGND	Power Ground.
C1	INN	Negative Audio Input Terminal.
C2	CTRL	Shutdown and ALC Mode Control.
C3	VOP	Positive BTL Audio Output Terminal.

IMPORTANT APPLICATION NOTES

1. When turning on the supply voltage or cancelling the shutdown mode, it must first enter ALC-1 mode as the default state. Be sure that the device stays in ALC-1 mode for a period longer than 10µs, and then lower the voltage level of the CTRL pin to enter other operating modes.
2. As a Class-D power audio amplifier, the SGM2821 requires adequate power supply decoupling to ensure its optimum performance such as output power, efficiency, and THD+N. Place a 10µF decoupling ceramic capacitor as close to the VDD pin as possible.
3. It is recommended to employ a ground plane for SGM2821 on the system board.
4. Use a simple ferrite bead filter for further EMI suppression. Choose a ferrite bead with a rated current which is no less than 2A or greater for applications with a load resistance less than 6Ω. Also, place the respective ferrite bead filters as close to the output pins, VOP and VON, as possible.
5. For applications where the power supply is rated more than 4.6V or the load resistance less than 6Ω, it is strongly recommended to add a simple snubber circuit (as shown in Figure 8) between the two output pins, VOP and VON, to prevent the device from accelerated deterioration or abrupt destruction due to excessive inductive flybacks that are induced on fast output switching or by an over-current or short-circuit condition.

TEST SETUP FOR PERFORMANCE TESTING

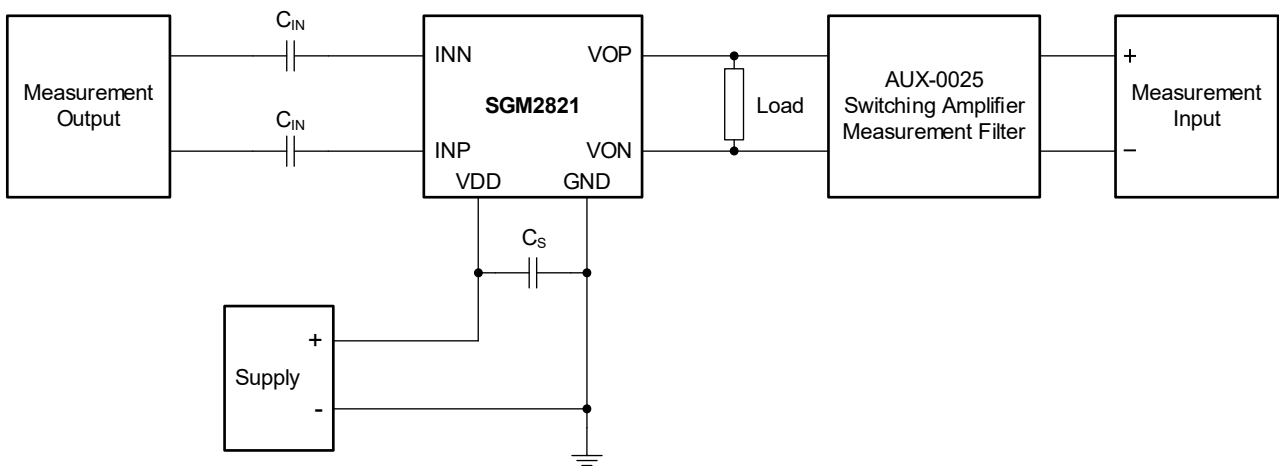

NOTE:
1. A 33µH inductor is placed in series with the load resistor to emulate a small speaker for efficiency measurements.

Figure 2. Test Block Diagram

ELECTRICAL CHARACTERISTICS

($T_A = -40^\circ\text{C}$ to $+85^\circ\text{C}$, $V_{DD} = 2.5\text{V}$ to 5.5V , $R_L = 8\Omega + 33\mu\text{H}$, Gain = 9V/V , $C_I = 0.1\mu\text{F}$, $f = 1\text{kHz}$, all typical values are at $T_A = +25^\circ\text{C}$, unless otherwise noted.)

PARAMETER	SYMBOL	CONDITIONS	MIN	TYP	MAX	UNITS
Supply Voltage	V_{DD}		2.5		5.5	V
Power-Up Threshold Voltage	V_{UVLU}	V_{DD} from Low-to-High		2.2	2.5	V
Power-Down Threshold Voltage	V_{UVLD}	V_{DD} from High-to-Low	1.8	2		V
Quiescent Current	I_{DD}	$V_{DD} = 2.5\text{V}$, No Load, Inputs AC-Grounded		2.0	3.6	mA
		$V_{DD} = 3.6\text{V}$, No Load, Inputs AC-Grounded		2.6	3.8	mA
		$V_{DD} = 5.5\text{V}$, No Load, Inputs AC-Grounded		3.3	4.5	mA
Shutdown Current	I_{SD}	CTRL Low		0.1	1.2	μA
Maximum Output Power $V_{DD} = 5\text{V}$, Load = $8\Omega + 33\mu\text{H}$	$P_{O, ALC-OFF}$	THD+N = 10%		1.7		W
		THD+N = 1%		1.4		
Maximum Output Power $V_{DD} = 3.6\text{V}$, Load = $8\Omega + 33\mu\text{H}$		THD+N = 10%		0.88		W
		THD+N = 1%		0.7		
Maximum Output Power $V_{DD} = 5\text{V}$, Load = $4\Omega + 33\mu\text{H}$	$P_{O, ALC-OFF}$	THD+N = 10%		3		W
		THD+N = 1%		2.4		
Maximum Output Power $V_{DD} = 3.6\text{V}$, Load = $4\Omega + 33\mu\text{H}$		THD+N = 10%		1.5		W
		THD+N = 1%		1.2		
Constant Output Power (ALC) Load = $8\Omega + 33\mu\text{H}$	$P_{O, ALC}$	$V_{IN} = 0.6\text{V}_{RMS}$, $V_{DD} = 5\text{V}$		1.25		W
		$V_{IN} = 0.4\text{V}_{RMS}$, $V_{DD} = 3.6\text{V}$		0.65		
Constant Output Power (ALC) Load = $4\Omega + 33\mu\text{H}$		$V_{IN} = 0.6\text{V}_{RMS}$, $V_{DD} = 5\text{V}$		2.2		W
		$V_{IN} = 0.4\text{V}_{RMS}$, $V_{DD} = 3.6\text{V}$		1.15		
Gain	A_V	$R_i = 0\Omega$	7.5	9	10.5	V/V
Maximum ALC Attenuation	A_{MAX}			13		dB
Output Resistance in Shutdown Mode	R_O	CTRL Low		2.5		$\text{k}\Omega$
Input Resistance	R_{IN}	@INP, INN		29		$\text{k}\Omega$
CTRL Input Resistance	R_{CTRL}			330		$\text{k}\Omega$
VREF Voltage	V_{REF}	$V_{DD} > 3\text{V}$		1.6		V
Total Harmonic Distortion + Noise Load = $8\Omega + 33\mu\text{H}$	THD+N	$V_{DD} = 3.6\text{V}$, $P_O = 0.5\text{W}$		0.05		%
		$V_{DD} = 5\text{V}$, $P_O = 1\text{W}$		0.05		
Total Harmonic Distortion + Noise Load = $4\Omega + 33\mu\text{H}$		$V_{DD} = 3.6\text{V}$, $P_O = 1\text{W}$		0.05		%
		$V_{DD} = 5\text{V}$, $P_O = 2\text{W}$		0.05		
Output Voltage Noise	V_N	A-Weighted, Gain = 19dB, Inputs AC-Grounded		110		μV_{RMS}
Output Offset Voltage	V_{OS}	Inputs AC-Grounded		± 15	± 55	mV
Efficiency	η	$V_{DD} = 5\text{V}$, $P_O = 1\text{W}$, $R_L = 8\Omega + 33\mu\text{H}$		88		%
Power Supply Rejection Ratio	PSRR	$f = 217\text{Hz}$		72		dB
Common Mode Rejection Ratio	CMRR	$V_{IN} = 0.2\text{V}_{RMS}$		55		dB
Startup Time	t_{STUP}			29		ms
PWM Carrier Frequency	f_{PWM}			500		kHz

ELECTRICAL CHARACTERISTICS (continued)

($T_A = -40^\circ\text{C}$ to $+85^\circ\text{C}$, $V_{DD} = 2.5\text{V}$ to 5.5V , $R_L = 8\Omega + 33\mu\text{H}$, Gain = 9V/V , $C_I = 0.1\mu\text{F}$, $f = 1\text{kHz}$, all typical values are at $T_A = +25^\circ\text{C}$, unless otherwise noted.)

PARAMETER	SYMBOL	CONDITIONS	MIN	TYP	MAX	UNITS
Over-Current Threshold	I_{LIMIT}	$V_{DD} = 5\text{V}$		2		A
Over-Temperature Threshold	T_{OTP}			160		$^\circ\text{C}$
Over-Temperature Hysteresis	T_{HYS}			30		$^\circ\text{C}$
ALC-1 Mode Setting Threshold Voltage	V_{MODE1}	$T_A = +25^\circ\text{C}$	1.48		V_{DD}	V
ALC-2 Mode Setting Threshold Voltage	V_{MODE2}	$T_A = +25^\circ\text{C}$	0.85		1.12	V
ALC-OFF Mode Setting Threshold Voltage	V_{MODE3}	$T_A = +25^\circ\text{C}$	0.4		0.58	V
Shutdown Mode Setting Threshold Voltage	V_{MODE4}	$T_A = +25^\circ\text{C}$	0		0.1	V

FUNCTIONAL BLOCK DIAGRAM

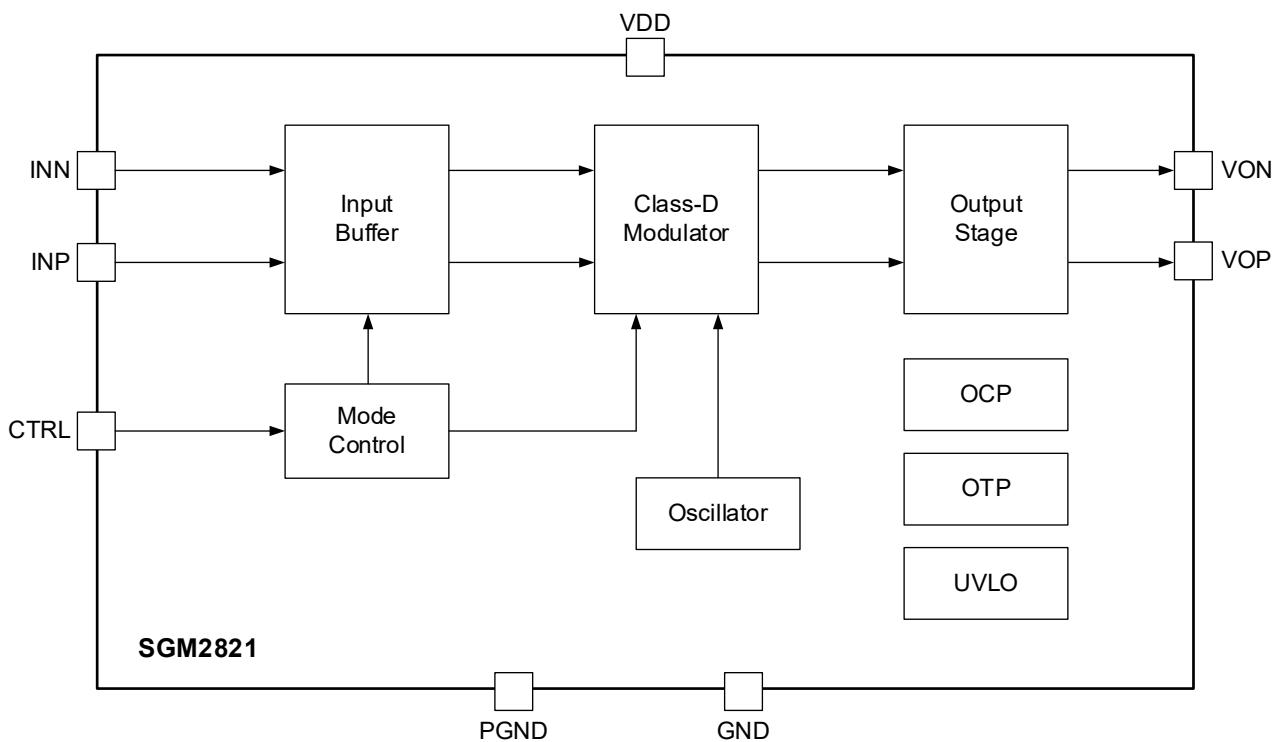
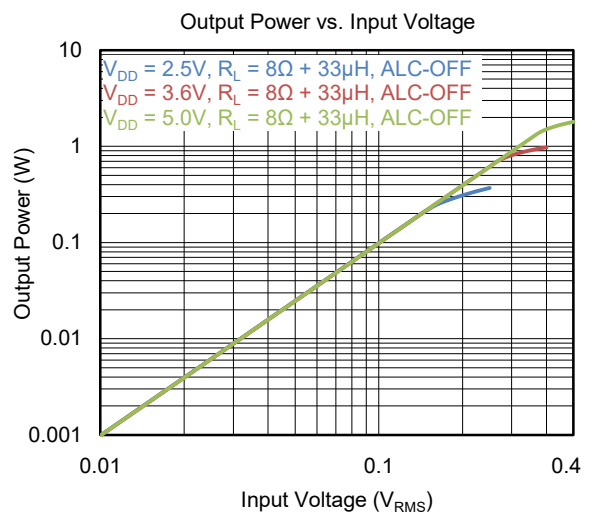
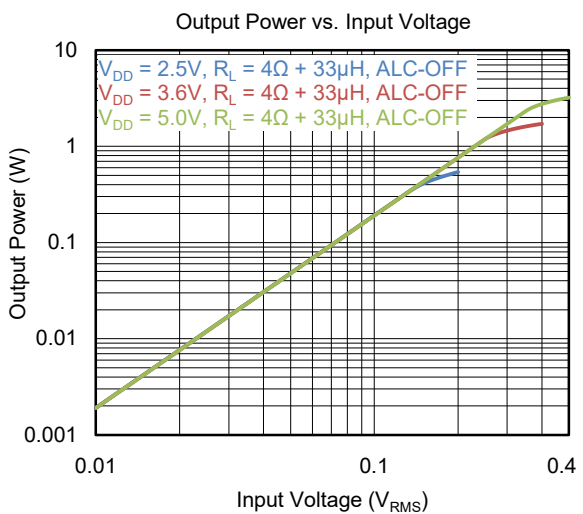
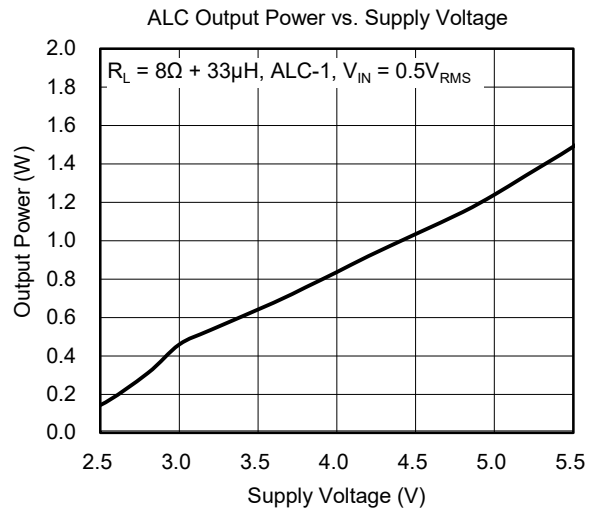
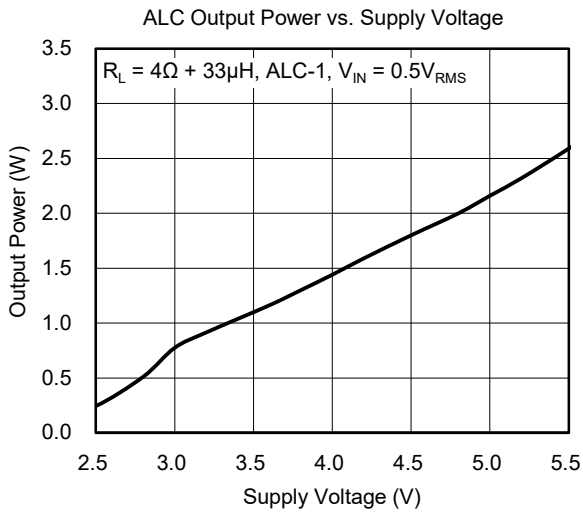
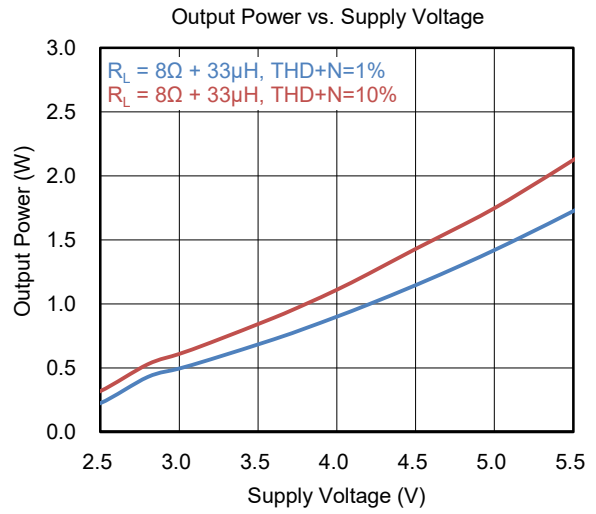
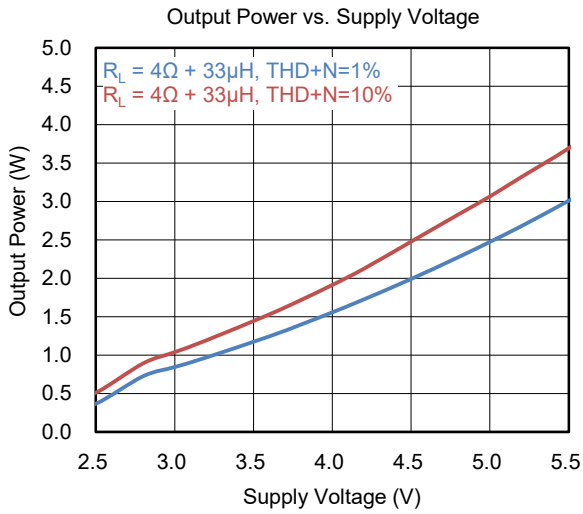

Figure 3. Block Diagram

TYPICAL PERFORMANCE CHARACTERISTICS

T_A = +25°C, V_{DD} = 3.6V, f = 1kHz, Gain = 9V/V, C_I = 0.1µF, unless otherwise noted.



TYPICAL PERFORMANCE CHARACTERISTICS (continued)

T_A = +25°C, V_{DD} = 3.6V, f = 1kHz, Gain = 9V/V, C_i = 0.1µF, unless otherwise noted.

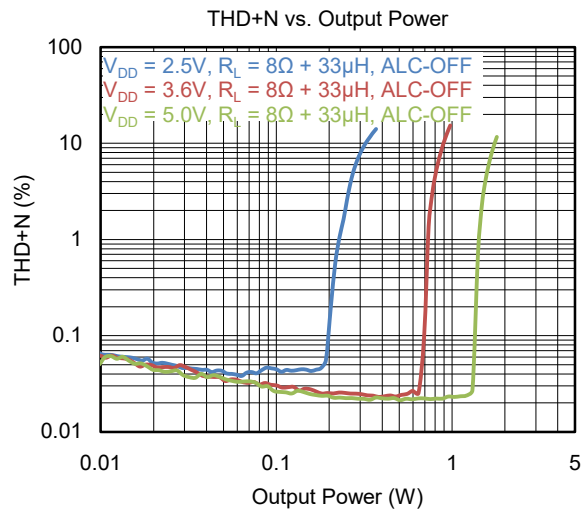
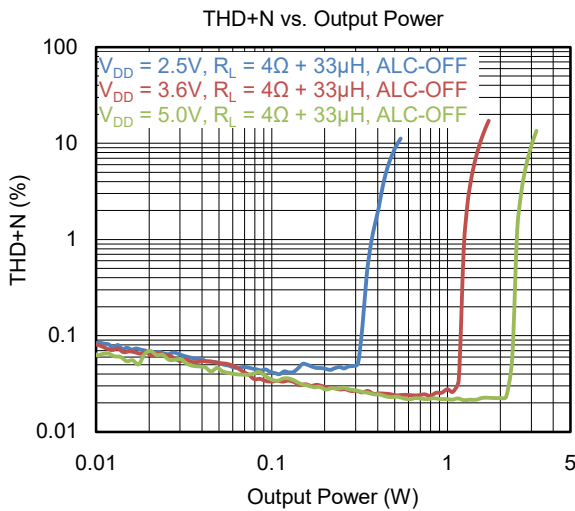
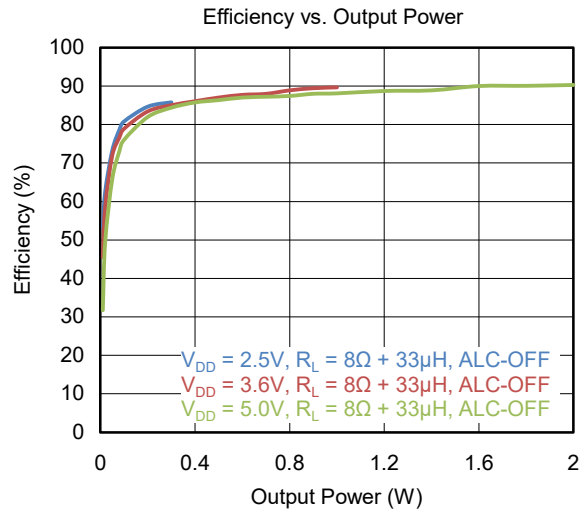
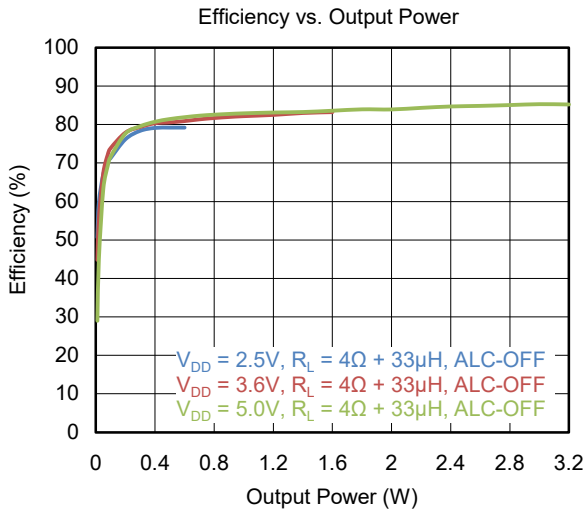
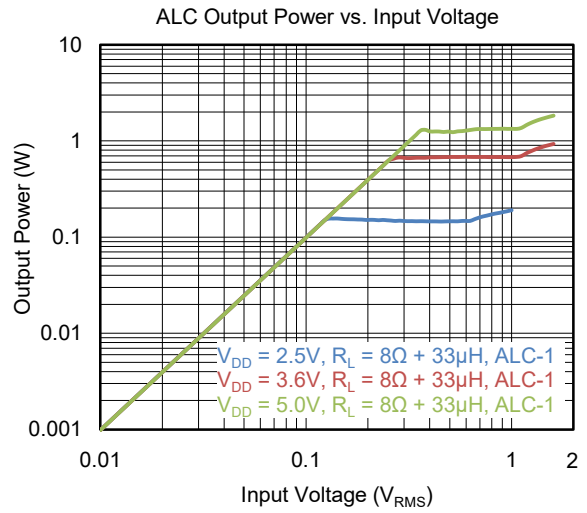
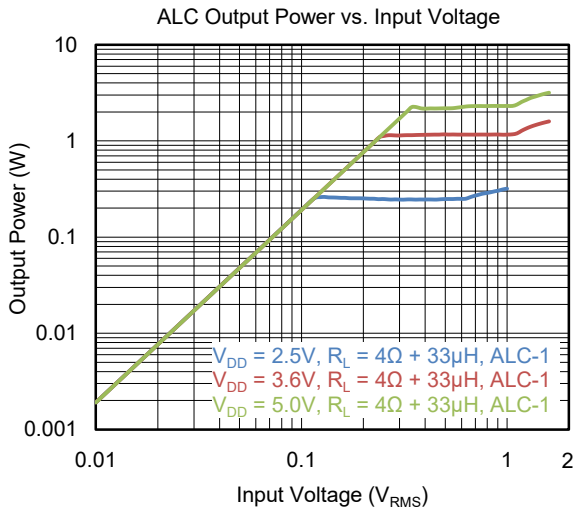

TYPICAL PERFORMANCE CHARACTERISTICS (continued)

T_A = +25°C, V_{DD} = 3.6V, f = 1kHz, Gain = 9V/V, C_I = 0.1µF, unless otherwise noted.

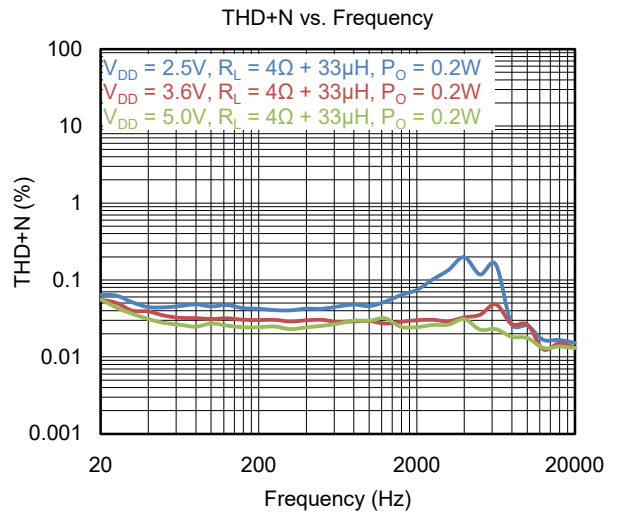
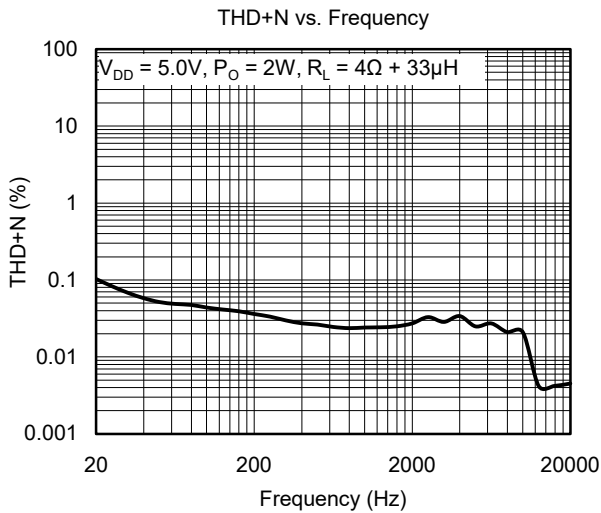
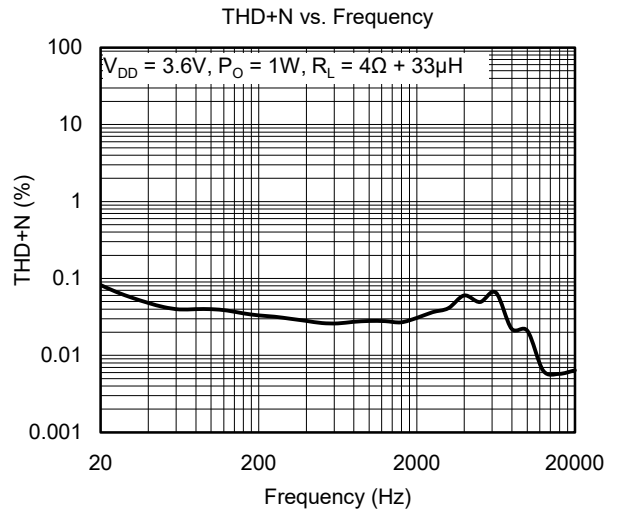
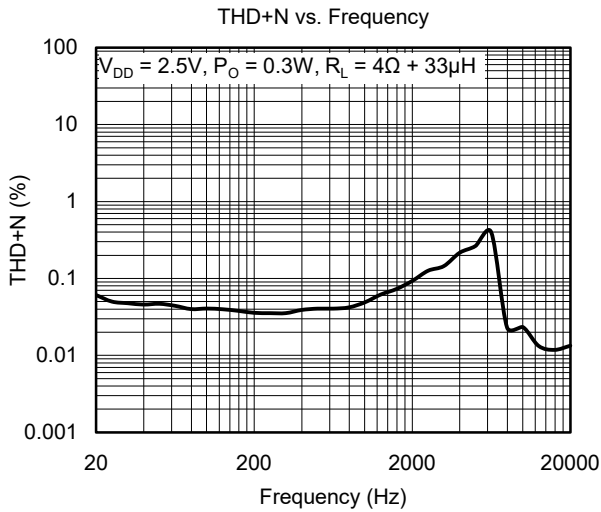
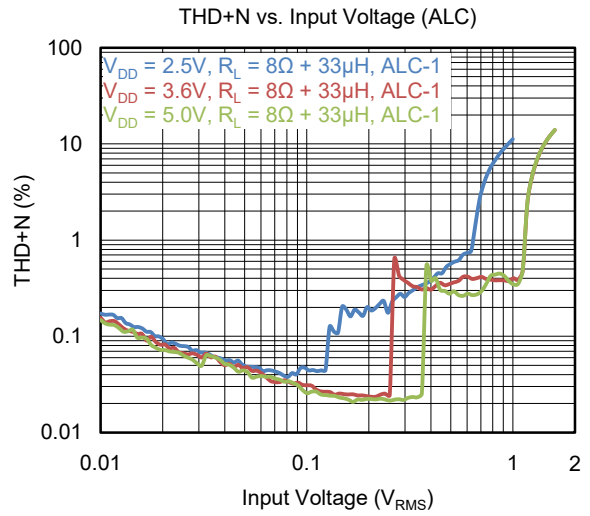
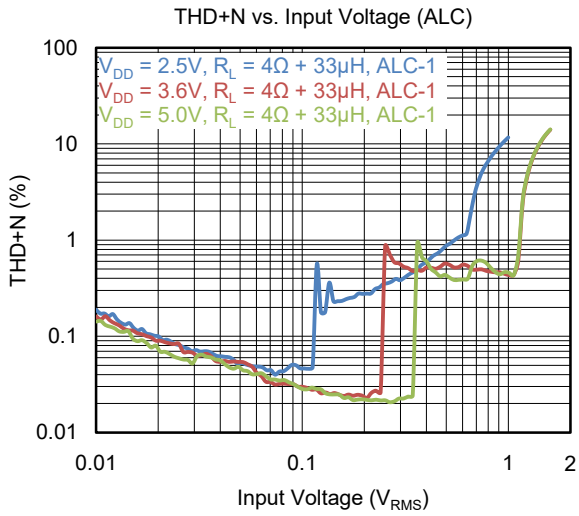

TYPICAL PERFORMANCE CHARACTERISTICS (continued)

T_A = +25°C, V_{DD} = 3.6V, f = 1kHz, Gain = 9V/V, C_I = 0.1µF, unless otherwise noted.

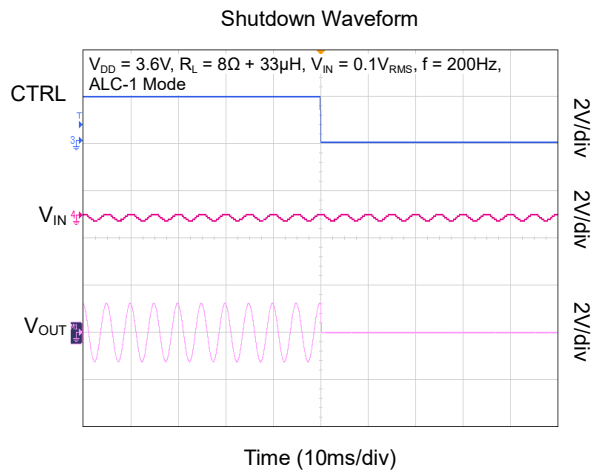
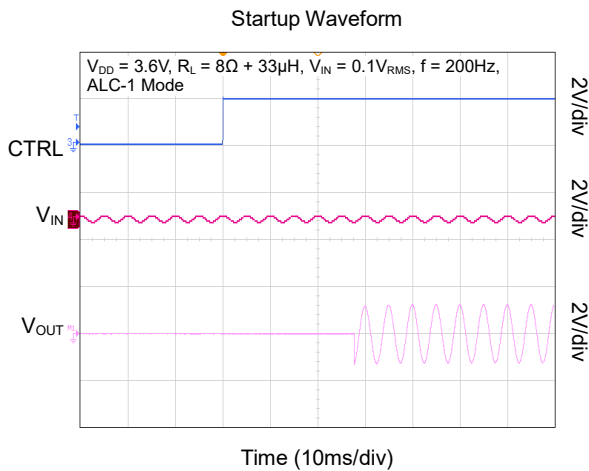
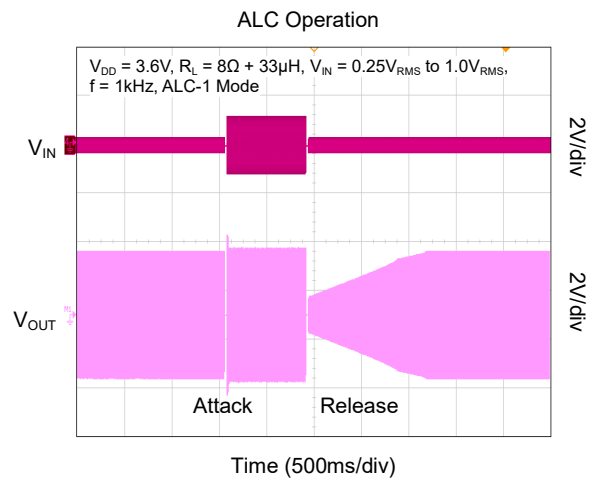
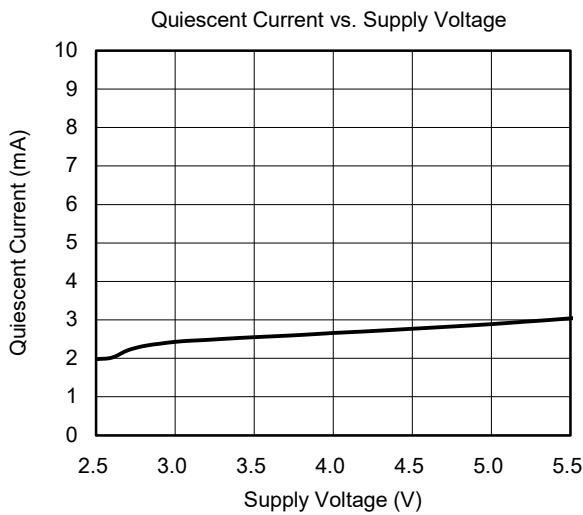
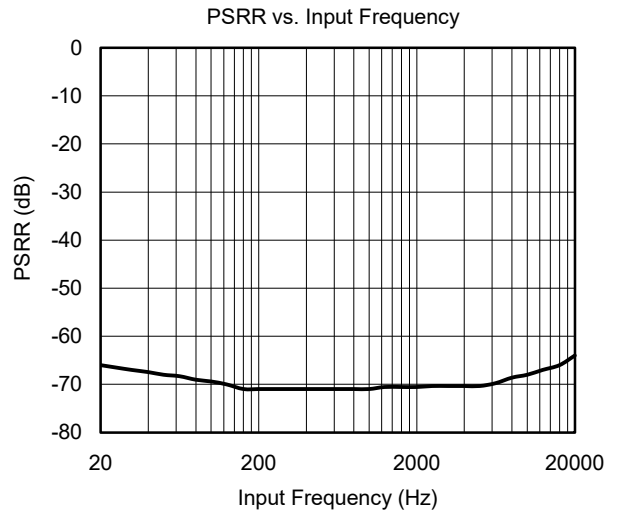
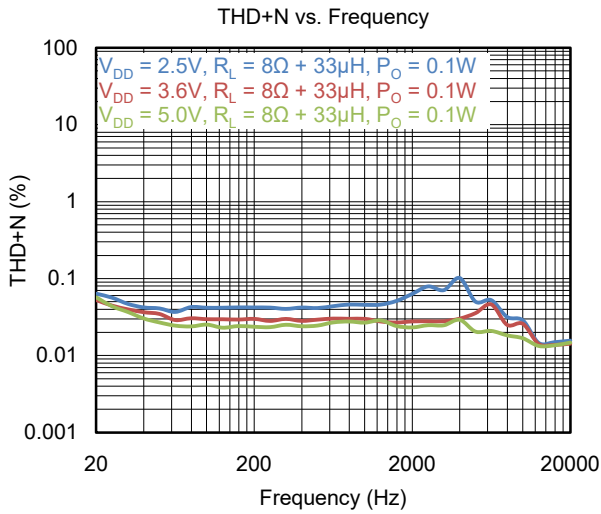

APPLICATION INFORMATION

The SGM2821 is a high efficiency, high-performance, filterless Class-D audio power amplifier with dual modes of Automatic Level Control (ALC). The SGM2821 operates from 2.5V to 5.5V supply. When powered with 5V supply voltage, the SGM2821 is capable of delivering up to 3W into a 4Ω load or 1.7W into an 8Ω load, with 10% THD+N in ALC-OFF mode.

As a Class-D power audio amplifier, the SGM2821 features 88% high efficiency and 72dB PSRR at 217Hz which make the device ideal for battery-supplied, high-quality audio applications. A key benefit of the SGM2821 over typical Class-D audio power amplifiers is that it generates much less EMI emissions, thus greatly simplifying the system design for portable applications. The device includes the circuitry can minimize turn-on and turn-off transients (also known as pops-and-clicks), as well as auto-recovering over-current protection (OCP) and short-circuit protection (SCP).

Furthermore, the SGM2821 includes under-voltage lockout to ensure proper operation when the device is first powered up, and thermal-overload protection to safeguard the die temperature during operation.

Fully Differential Amplifier

The SGM2821 is configured in a fully differential topology. The fully differential topology ensures that the amplifier outputs a differential voltage on the output that is equal to the differential input times the gain. The common-mode feedback ensures that the common-mode voltage at the output is biased around 1.6V

regardless of the common-mode voltage at the input. Although the fully differential topology of the SGM2821 can still be used with a single-ended input, it is highly recommended that the SGM2821 be used with differential inputs in a noisy environment, like a wireless handset, to ensure maximum noise rejection.

Automatic Level Control (ALC)

The automatic level control is to maintain the audio output signals for a maximum voltage swing without distortion when an excessive input that may cause output clipping is applied. With the ALC function, the SGM2821 lowers the voltage gain of the amplifier to an appropriate value such that the clipping at the outputs is eliminated. It also eliminates the clipping of the output signal due to the reduction of the power-supply voltage.

The attack time and release time of the ALC are separately set for ALC-1 and ALC-2 modes, as shown in Table 1. The attack time is defined as the time interval required for the gain fall to its steady-state gain, assumed that a sufficiently large input signal is applied. The release time is the time interval required for the amplifier to exit out of the present mode of operation.

Table 1. Attack Time and Release Time

Mode	Attack Time	Release Time
ALC-1	25ms	1.2s
ALC-2	6ms	0.6s

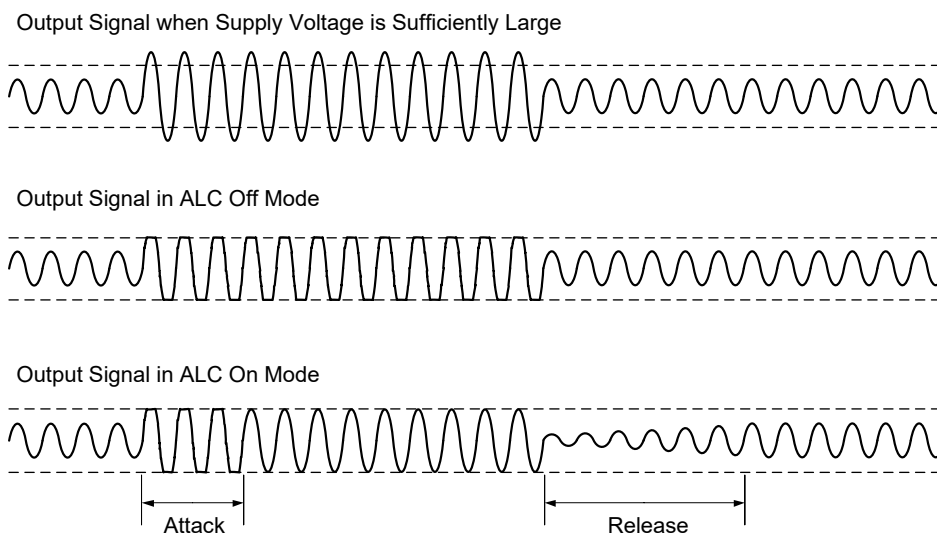

Figure 4. Automatic Level Control Diagram

APPLICATION INFORMATION (continued)

Mode Control

Shutdown and Startup

When the CTRL pin is pulled to ground, the SGM2821 is forced into the shutdown mode. In the shutdown mode, all the circuitry is disabled and the supply current is eliminated except leakage current, and the differential outputs are shorted to ground through an internal resistor (2.5kΩ) individually. Once in the shutdown mode, the CTRL pin must remain low for at least 1ms (the shutdown settling time), before it can be brought high again. When the CTRL pin is asserted high, the device exits out of the shutdown mode and enters into the ALC-1 mode after a startup time (t_{STUP}) of 29ms.

CTRL Voltage Setting

The mode of operation in SGM2821 is determined by the voltage applied to the CTRL pin. An example of setting the mode of operation by a host processor or microcontroller is shown in Figure 5. As depicted in the Figure 5, three external resistors (R_{CTRL1} , R_{CTRL2} and R_{CTRL3} with $\pm 1\%$ accuracy) connected to the CTRL pin and two GPIO ports from the host are used to set the voltage at the CTRL pin. By asserting the two GPIO pins high or low, 4 modes of operation (ALC-1, ALC-2, ALC-OFF and Shutdown) are defined, as described in Table 2. It is recommended to add a ceramic capacitor ($\geq 0.1\mu F$) to the CTRL pin to smooth out the mode transition as well as to minimize noise interference.

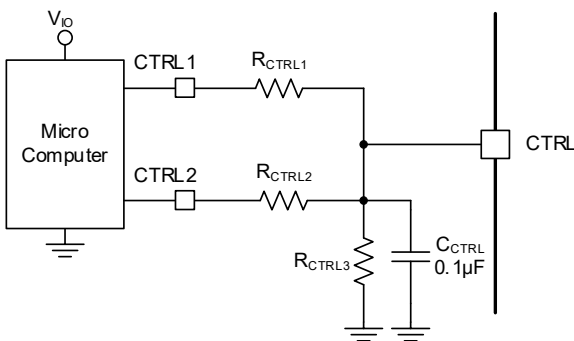

Figure 5. Mode Control Circuit 1

Table 2. 4-Mode Control

CTRL1	CTRL2	MODE
H	H	ALC-1
H	L	ALC-2
L	H	ALC-OFF
L	L	Shutdown Mode

In Table 2, 'H' indicates a high-level output voltage (V_{IO}) at the host's I/O ports. 'L' indicates a low-level output voltage (GND) at the ports. To generate a proper voltage at the CTRL pin for a specific mode of operation, the two GPIO ports are required to have sufficient pull-down capability. Also, the ground (GND) of the host must be at the same potential as that of SGM2821. Furthermore, the voltage at the CTRL pin is a function of the supply voltage (V_{IO}) applied onto the host. Table 3 defines suitable resistors to be used for various supply voltages at V_{IO} .

Table 3. CTRL Circuit Setup

V_{IO}	1.8V	2.5V	3.0V	3.3V	5.0V
R_{CTRL1}	6.81kΩ	26.7kΩ	34.0kΩ	34.0kΩ	68.1kΩ
R_{CTRL2}	13.7kΩ	53.6kΩ	68.1kΩ	68.1kΩ	137kΩ
R_{CTRL3}	27.4kΩ	30.9kΩ	25.5kΩ	21.5kΩ	21.5kΩ

In applications where only ALC-1 and shutdown modes are needed, the CTRL circuit diagram can be simplified as shown in Figure 6. In this case, one external resistor (R_{CTRL1}) and one GPIO port are used to set the voltage at the CTRL pin. The value of the resistor is chosen such that the resulting RC time constant ($\geq 1ms$) will provide sufficient noise rejection at the CTRL pin. Two modes of operation (ALC-1 and Shutdown) are defined, as described in Table 4. It is recommended to add a ceramic capacitor ($\geq 0.1\mu F$) to the CTRL pin to smooth out the mode transition as well as to minimize noise interference.

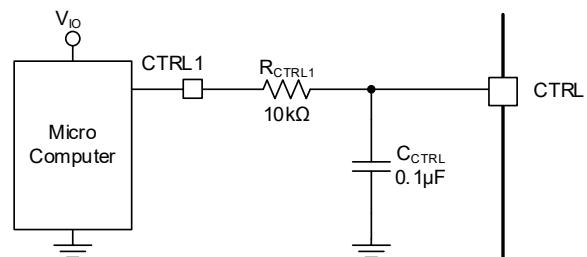

Figure 6. Mode Control Circuit 2

Table 4. 2-Mode Control

CTRL1	MODE
H	ALC-1
L	Shutdown Mode

APPLICATION INFORMATION (continued)

Mode Transition

When SGM2821 exits shutdown mode to working state, it must first enter ALC-1 mode as the default state. Be sure that the device stays in ALC-1 mode for a period longer than 10 μ s. After the startup, the device can be configured into another active state, either ALC-2 or ALC-OFF, and can also transition back and forth among three active modes as dictated by the host without constraints.

Filterless Design

Traditional Class-D amplifiers require an output filter. The filter adds cost and the size of the system board. Furthermore, it degrades the performance of power efficiency and THD+N. The SGM2821's filterless modulation scheme does not require an output filter. Because the switching frequency of the SGM2821 is well beyond the bandwidth of most speakers, voice coil movement due to the switching frequency is very small. Use a speaker with a series inductance larger than 10 μ H. An 8 Ω speaker typically exhibits a series inductance in the range from 20 μ H to 100 μ H.

However, LC filter is required when the trace between the SGM2821 and the speaker exceeds 100mm. Long trace acts like tiny antenna and generates EMI emissions which may result in FCC and CE certification failures.

Low EMI Design

Traditional Class-D amplifiers require the use of external LC filters, or shielding, to minimize EMI emissions. The SGM2821 uses a proprietary edge-rate-controlled (ERC) circuitry to reduce EMI emissions, while maintaining high efficiency.

How to Reduce EMI

The SGM2821 does not require an LC output filter for short connections from the amplifier to the speaker. However, additional EMI suppressions can be made by use of a ferrite bead in conjunction with a capacitor, as shown in Figure 7. Choose a ferrite bead with low DC resistance (DCR) and high impedance (100 Ω ~ 330 Ω) at high frequencies (> 100MHz). The current flowing through the ferrite bead must be also taken into consideration. The effectiveness of ferrites can be

greatly aggravated at much lower than the rated current values. Choose a ferrite bead with at least 2A rated current. The capacitor value varies based on the chosen ferrite bead and the actual speaker lead length. Choose a capacitor less than 1nF based on EMI performance.

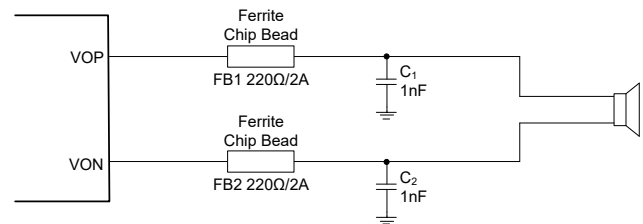

Figure 7. Ferrite Bead Filter to Reduce EMI

RC Snubber Circuit

For applications where the power supply is rated more than 4.6V or the load resistance less than 6 Ω , it may become necessary to add an RC snubber circuit between the two output pins, VOP and VON, for robustness and reliability. Figure 8 shows a simple RC snubber circuit, which can be used to prevent the device from accelerated deterioration or abrupt destruction due to excessive inductive flybacks that are induced on fast output switching or by an over-current or short-circuit condition.

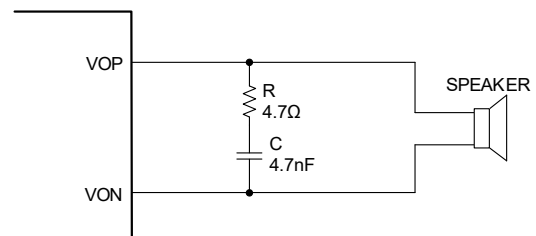

Figure 8. RC Snubber Circuit

Under-Voltage Lockout (UVLO)

The SGM2821 incorporates circuitry designed to detect a low supply voltage. When the supply voltage drops below 2V (TYP), the SGM2821 goes into shutdown mode. The device will emerge out of the shutdown mode and resume its normal operation only when the supply voltage is restored to above 2.2V (TYP) and the CTRL pin is pulled high.

APPLICATION INFORMATION (continued)**Auto-Recovering Over-Current Protection (OCP) & Short-Circuit Protection (SCP)**

Once an over-current or a short-circuit condition at the differential outputs is detected, either to the power supply or to ground or to each other, the SGM2821 goes into shutdown mode. During shutdown, the SGM2821 activates auto-recovering process whose aim is to return the device to normal operation once the fault condition is removed. This process repeatedly examines if the fault condition persists, and returns the device to normal operation immediately after the fault condition is removed. This feature helps protect the device from large currents and maintain long-term reliability while removing the need for external system interaction to resume normal operation.

Over-Temperature Shutdown (OTSD)

The thermal-overload protection on the SGM2821 prevents the device from being damaged when the die temperature exceeds +160°C. Once the die temperature exceeds the prescribed value, the device will be forced into shutdown mode and the outputs are disabled. Note that this is not a latched fault. Instead, the thermal fault will be cleared once the temperature of the die is lowered by 30°C. This large hysteresis will prevent it from generating motor boating sound and allow the device resume normal operation without the need for external system interaction.

Pop-and-Click Suppression

When asserting CTRL pin from low to high level, the SGM2821 features a 29ms startup turn-on time to suppress the click-pop noise. For the best power-off pop performance, the amplifier should be placed in shutdown mode before removing the power supply voltage.

Decoupling Capacitor (C_S)

The decoupling capacitor stabilizes the power supply voltage applied onto the SGM2821, thus improving its THD performance. It also prevents voltage ringing with a long lead. A ceramic capacitor of 10μF with low equivalent-series-resistance (ESR) is required for decoupling and to be placed as close to the SGM2821 as possible to minimize the resistance and inductance of the traces between the device and the capacitor. To filter out lower-frequency noise, a capacitor of 100μF or greater should be placed close to the SGM2821.

Input Capacitors (C_I)

The input capacitors and input resistors determine the corner frequency of the high-pass filter. The corner frequency (f_c) is calculated with the Equation 1.

$$f_c = \frac{1}{2\pi R_i C_i} \quad (1)$$

where R_i = 29kΩ.

The corner frequency directly influences the low frequency signals and consequently determines output bass quality.

PCB Layout

As the output power increases, the interconnect resistance (PCB traces and wires) among the audio amplifier, load, and power supply creates a voltage drop. The voltage loss on the traces between the SGM2821 and the load results in lower output power and lower efficiency. The higher trace resistance between the supply and the SGM2821 has the same effect as a poorly regulated supply, increasing the voltage ripples on the supply line and also reducing the peak output power. The effect of the residual trace resistance will be intensified as the output current increases. To maintain the highest output voltage swing for a maximum output power, the PCB traces that connect the output pins to the load and the supply pins to the power supply should be as wide and short as possible to minimize trace resistance.

The use of power and ground planes will give the best THD+N performance. While reducing trace resistance, the use of power planes also creates parasitic capacitors that help filter the power supply line.

The inductive nature of the speakers can also result in overshoots on one or both edges, clamped by the parasitic diodes to ground and VDD in each case. From an EMI standpoint, this is the highly unfavorable waveform that will radiate or conduct to other components on the system board and cause interference. It is essential to keep the power and output traces short and well shielded if possible. Use of ground planes, beads, and micro-strip layout techniques are all useful in preventing unwanted interference.

APPLICATION INFORMATION (continued)

As the distance from the SGM2821 to the speaker increases, the amount of EMI radiation will increase since the output wires or traces acting as antenna become more efficient with their lengths. Acceptable EMI is highly application specific. Ferrite beads placed close to the SGM2821 may be needed to reduce EMI radiation. The value of the ferrite beads is also application specific.

TYPICAL APPLICATION CIRCUITS

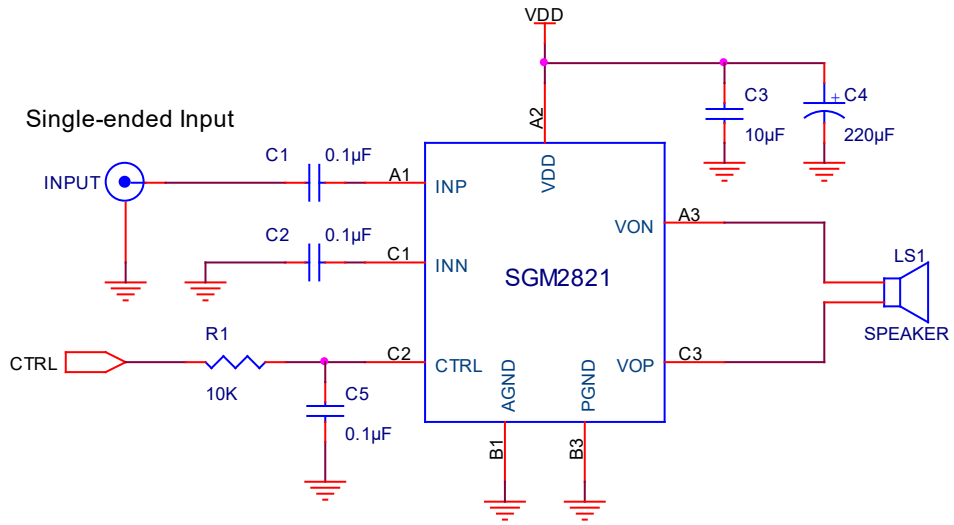

Figure 9. Single-Ended Input with One Control Signal (for 2-Mode Operation)

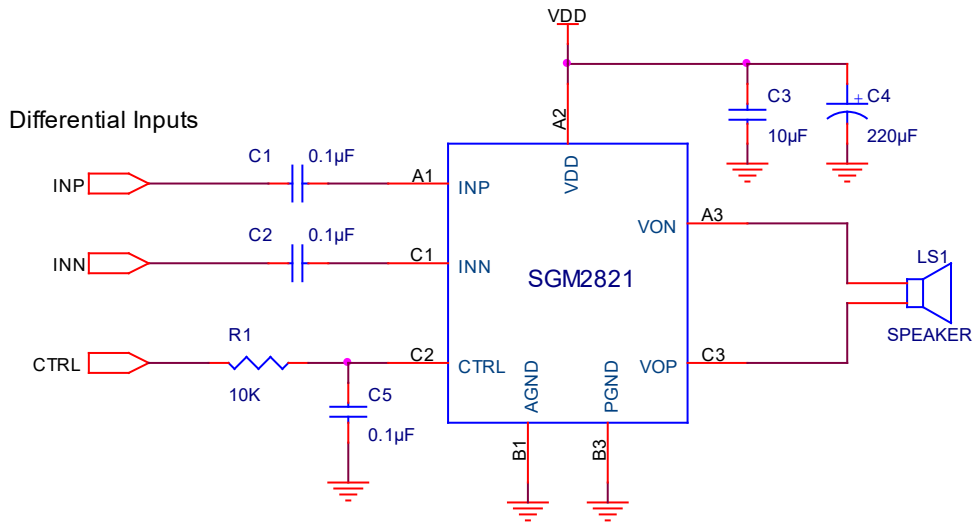

Figure 10. Differential Input with One Control Signal (for 2-Mode Operation)

SGM2821

3W Low EMI Class-D Audio Power Amplifier with Dual Mode of Automatic Level Control

TYPICAL APPLICATION CIRCUITS (continued)

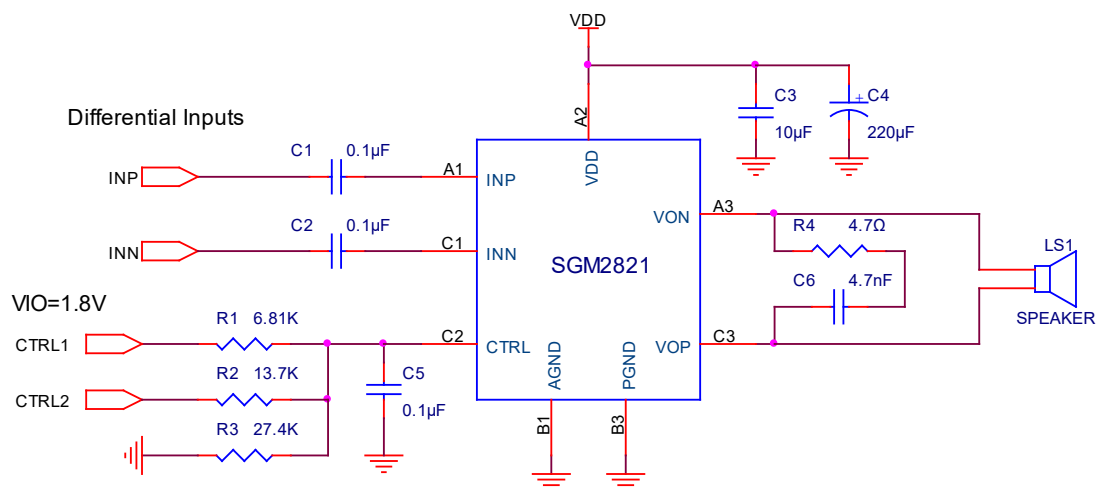

Figure 11. Differential Inputs with Two Control Signals (for 4-Mode Operation)

REVISION HISTORY

NOTE: Page numbers for previous revisions may differ from page numbers in the current version.

Changes from Original (OCTOBER 2023) to REV.A	Page
Changed from product preview to production data.....	All

PACKAGE OUTLINE DIMENSIONS

UTQFN-1.5×1.5-9L

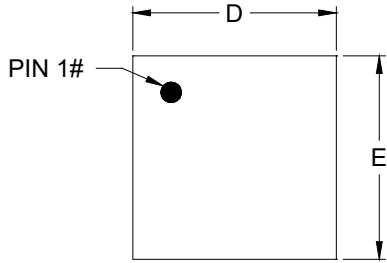

TOP VIEW

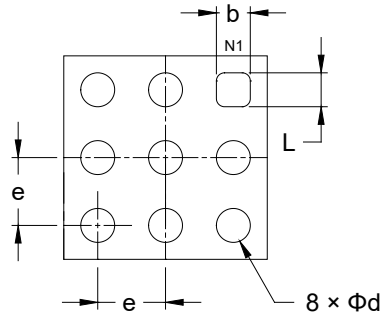

BOTTOM VIEW

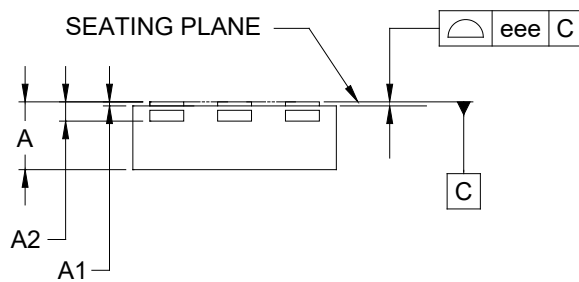

SIDE VIEW

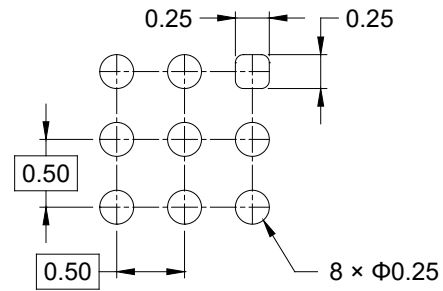

RECOMMENDED LAND PATTERN (Unit: mm)

Symbol	Dimensions In Millimeters		
	MIN	MOD	MAX
A	0.450	-	0.550
A1	0.000	-	0.050
A2	0.152 REF		
b	0.174	-	0.326
D	1.400	-	1.600
E	1.400	-	1.600
d	0.174	-	0.326
e	0.500 BSC		
L	0.174	-	0.326
eee	0.050		

NOTE: This drawing is subject to change without notice.

TAPE AND REEL INFORMATION

REEL DIMENSIONS



TAPE DIMENSIONS



NOTE: The picture is only for reference. Please make the object as the standard.

KEY PARAMETER LIST OF TAPE AND REEL

Package Type	Reel Diameter	Reel Width W1 (mm)	A0 (mm)	B0 (mm)	K0 (mm)	P0 (mm)	P1 (mm)	P2 (mm)	W (mm)	Pin1 Quadrant
UTQFN-1.5×1.5-9L	7"	9.5	1.70	1.70	0.75	4.0	4.0	2.0	8.0	Q1

000001

PACKAGE INFORMATION

CARTON BOX DIMENSIONS



NOTE: The picture is only for reference. Please make the object as the standard.

KEY PARAMETER LIST OF CARTON BOX

Reel Type	Length (mm)	Width (mm)	Height (mm)	Pizza/Carton
7" (Option)	368	227	224	8
7"	442	410	224	18

DD0002