

### GENERAL DESCRIPTION

The SGM855 is a nano-power system timer which only consumes 40nA (TYP) quiescent current. It has a programmable watchdog to interrupt the power MOSFET with the DRV pin. Hence, it is suitable for power gating in duty-cycled or battery-powered applications. Due to the power saving feature of SGM855, smaller battery can be adopted under power collection system or wireless sensor applications. The SGM855 can program the timer interval from 100ms to 8200s through the resistor placed between the DELAY/M\_DRV pin and GND. Besides, the user can choose the timer to operate in timer mode or one-shot mode by the EN/ONE\_SHOT pin.

The SGM855 is available a Green SOT-23-6 Package.

### FEATURES

- **Supply Voltage Range: 1.8V to 5.5V**
- **Low Current Consumption: 40nA (TYP) at 2.5V**
- **Programmable Time Intervals: 100ms to 8200s**
- **Timer Accuracy: 1% (TYP)**
- **Resistor Selectable Time Interval**
- **Manual MOSFET Power-On**
- **One-Shot Feature**
- **Available in a Green SOT-23-6 Package**

### APPLICATIONS

- Battery-Powered Systems
- Internet of Things (IoT)
- Anti-Intrusion System
- Anti-Tamper System
- Home Automation Sensors
- Temperature Regulating System
- Consumer Electronics
- Wireless Sensor
- White Household Appliances
- Industrial Applications

### TYPICAL APPLICATION

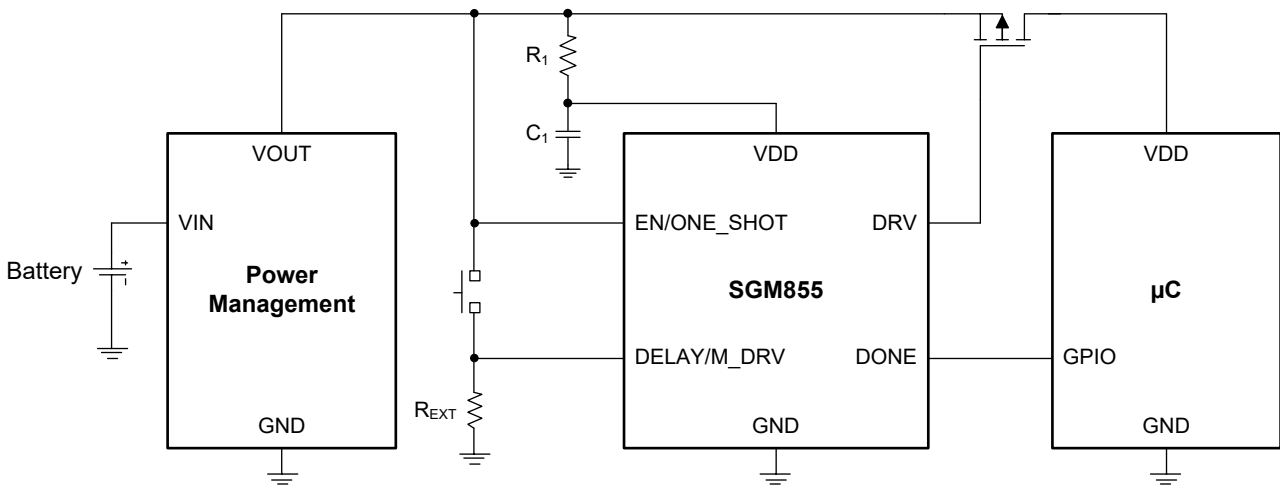

Figure 1. Typical Application Circuit

**PACKAGE/ORDERING INFORMATION**

| MODEL  | PACKAGE DESCRIPTION | SPECIFIED TEMPERATURE RANGE | ORDERING NUMBER | PACKAGE MARKING | PACKING OPTION      |
|--------|---------------------|-----------------------------|-----------------|-----------------|---------------------|
| SGM855 | SOT-23-6            | -40°C to +105°C             | SGM855GN6G/TR   | 1H5<br>XXXXX    | Tape and Reel, 3000 |

**MARKING INFORMATION**

NOTE: XXXXX = Date Code, Trace Code and Vendor Code.

**XXXXX**

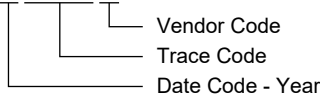

Green (RoHS & HSF): SG Micro Corp defines "Green" to mean Pb-Free (RoHS compatible) and free of halogen substances. If you have additional comments or questions, please contact your SGMICRO representative directly.

**ABSOLUTE MAXIMUM RATINGS**

- Supply Voltage,  $V_{DD}$ ..... -0.3V to 6V
- Input Voltage at Any Pin <sup>(1)</sup>.....-0.3V to  $V_{DD} + 0.3V$
- Package Thermal Resistance
- SOT-23-6,  $\theta_{JA}$ ..... 131.9°C/W
- SOT-23-6,  $\theta_{JB}$ ..... 31.2°C/W
- SOT-23-6,  $\theta_{JC}$ ..... 61°C/W
- Junction Temperature.....+150°C
- Storage Temperature Range.....-65°C to +150°C
- Lead Temperature (Soldering, 10s).....+260°C
- ESD Susceptibility <sup>(2) (3)</sup>
- HBM..... ±4000V
- CDM..... ±1000V

**NOTES:**

1. The voltage between any two pins should not exceed 6V.
2. For human body model (HBM), all pins comply with ANSI/ESDA/JEDEC JS-001 specifications.
3. For charged device model (CDM), all pins comply with ANSI/ESDA/JEDEC JS-002 specifications.

**RECOMMENDED OPERATING CONDITIONS**

- Supply Voltage,  $V_{DD}$ .....1.8V to 5.5V
- Operating Temperature Range.....-40°C to +105°C

**OVERSTRESS CAUTION**

Stresses beyond those listed in Absolute Maximum Ratings may cause permanent damage to the device. Exposure to absolute maximum rating conditions for extended periods may affect reliability. Functional operation of the device at any conditions beyond those indicated in the Recommended Operating Conditions section is not implied.

**ESD SENSITIVITY CAUTION**

This integrated circuit can be damaged if ESD protections are not considered carefully. SGMICRO recommends that all integrated circuits be handled with appropriate precautions. Failure to observe proper handling and installation procedures can cause damage. ESD damage can range from subtle performance degradation to complete device failure. Precision integrated circuits may be more susceptible to damage because even small parametric changes could cause the device not to meet the published specifications.

**DISCLAIMER**

SG Micro Corp reserves the right to make any change in circuit design, or specifications without prior notice.

**PIN CONFIGURATION**

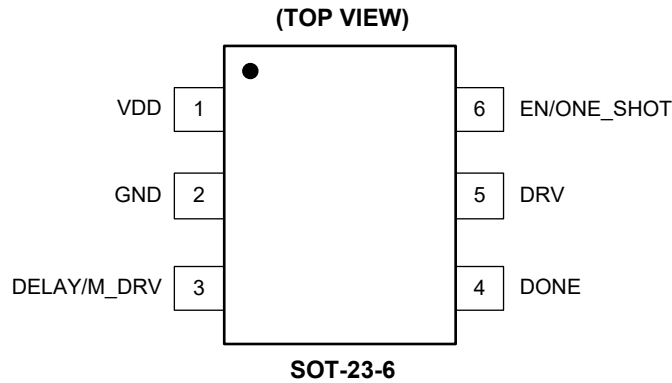

**PIN DESCRIPTION**

| PIN | NAME        | TYPE | FUNCTION   |
|-----|-------------|------|--|
| 1   | VDD         | P    | Supply Voltage Pin.  |
| 2   | GND         | G    | Ground.  |
| 3   | DELAY/M_DRV | I    | Time Interval Set and Manual MOSFET Power-On. Putting a resistor between the DELAY/M_DRV pin and GND determines the time interval. It can also be used to turn on the MOSFET manually.   |
| 4   | DONE        | I    | Watchdog Input Pin. Periodically logic high at this pin means correct operation of the microcontroller.  |
| 5   | DRV         | O    | Power MOSFET Driving Pin. Connect this pin to the gate of the MOSFET. The power MOSFET is on when DRV goes low.  |
| 6   | EN/ONE_SHOT | I    | Mode Selection Pin. When EN/ONE_SHOT is logic high, the SGM855 works in timer mode. When EN/ONE_SHOT is logic low, the SGM855 works in one-shot mode and the power MOSFET will be turned on again until a new active DELAY/M_DRV occurs. |

NOTE: I = input, O = output, P = power, G = ground.

**ELECTRICAL CHARACTERISTICS**(V<sub>DD</sub> = 2.5V, T<sub>J</sub> = +25°C, unless otherwise noted.)

| PARAMETER  | SYMBOL               | CONDITIONS  | MIN                   | TYP                   | MAX                   | UNITS  |    |
|--|----------------------|---|-----------------------|-----------------------|-----------------------|--------|----|
| <b>Power Supply</b>                                |                      |   |                       |                       |                       |        |    |
| Supply Current at Operation Mode                   | I <sub>DD_OP</sub>   |   |                       | 40                    | 55                    | nA     |    |
| Supply Current at Sense Mode <sup>(1)</sup>        | I <sub>DD_SEN</sub>  | Digital conversion of external resistance (R <sub>EXT</sub> ) |                       | 120                   | 150                   | μA     |    |
| <b>Timer</b>                                       |                      |   |                       |                       |                       |        |    |
| Time Interval Period                               | t <sub>IP</sub>      | 1650 selectable time intervals                                | Minimum time interval |                       | 100                   | ms     |    |
|  |                      |   | Maximum time interval |                       | 8200                  | s      |    |
| Time Interval Setting Accuracy <sup>(2)</sup>      |                      | Excluding reliability test                                    |                       |                       | ±2.6                  | %      |    |
|  |                      | Including reliability test                                    |                       |                       | ±3.5                  |        |    |
| Resistance Detection Accuracy over Temperature     |                      | T <sub>J</sub> = -40°C to +105°C                              |                       |                       | 90                    | ppm/°C |    |
| Time Interval Setting Accuracy over Supply Voltage |                      | V <sub>DD</sub> = 1.8V to 5.5V                                |                       |                       | ±0.06                 | %/V    |    |
| Oscillator Accuracy                                | t <sub>OSC</sub>     | Excluding reliability test                                    |                       |                       | ±1.0                  | %      |    |
|  |                      | Including reliability test                                    |                       |                       | ±2.1                  |        |    |
| Oscillator Accuracy over Temperature               |                      | T <sub>J</sub> = -40°C to +105°C                              |                       |                       | 200                   | ppm/°C |    |
| Oscillator Accuracy over Supply Voltage            |                      | V <sub>DD</sub> = 1.8V to 5.5V                                |                       |                       | ±0.13                 | %/V    |    |
| DONE Pulse Width                                   | t <sub>DONE</sub>    |   |                       | 100                   |                       | ns     |    |
| DRV Pulse Width                                    | t <sub>DRV</sub>     | DONE signal not received                                      |                       |                       | 320                   | ms     |    |
| Time to Convert R <sub>EXT</sub>                   | t <sub>R_EXT</sub>   |   |                       |                       | 100                   | 120    | ms |
| <b>Digital Logic Levels</b>                        |                      |   |                       |                       |                       |        |    |
| Logic High Threshold DONE Pin                      | V <sub>IH</sub>      |   |                       | 0.7 × V <sub>DD</sub> |                       | V      |    |
| Logic Low Threshold DONE Pin                       | V <sub>IL</sub>      |   |                       |                       | 0.3 × V <sub>DD</sub> | V      |    |
| Logic Output High Level DRV Pin                    | V <sub>OH</sub>      | I <sub>OUT</sub> = 100μA                                      |                       | V <sub>DD</sub> - 0.3 |                       | V      |    |
|  |                      | I <sub>OUT</sub> = 1mA  |                       | V <sub>DD</sub> - 0.7 |                       | V      |    |
| Logic Output Low Level DRV Pin                     | V <sub>OL</sub>      | I <sub>OUT</sub> = -100μA                                     |                       |                       | 0.3                   | V      |    |
|  |                      | I <sub>OUT</sub> = -1mA                                       |                       |                       | 0.7                   | V      |    |
| Logic High Threshold DELAY/M_DRV Pin               | V <sub>IHM_DRV</sub> |   |                       | 1.5                   |                       | V      |    |

## NOTES:

- Current of load and pull-up resistor are not included.
- This accuracy represents the error of different chip detection results when the external resistance is the same ideal resistance, excluding the error of the external resistance itself.

**TIMING REQUIREMENTS**

| PARAMETER                        | SYMBOL          | CONDITIONS            | MIN | TYP | MAX | UNITS |
|----------------------------------|-----------------|-----------------------|-----|-----|-----|-------|
| Rise Time DRV <sup>(1)</sup>     | $t_{R\_DRV}$    | Capacitive load 50pF  |     | 50  |     | ns    |
| Fall Time DRV <sup>(1)</sup>     | $t_{F\_DRV}$    | Capacitive load 50pF  |     | 50  |     | ns    |
| DONE to DRV Delay <sup>(1)</sup> | $t_{DLY\_DONE}$ |                       |     | 100 |     | ns    |
| Valid Manual MOSFET Power-On     | $t_{M\_DRV}$    | Observation time 30ms | 20  |     |     | ms    |
| De-Bounce Manual MOSFET Power-On | $t_{DB}$        |                       |     | 20  |     | ms    |

NOTS:

- 1. Guaranteed by design.

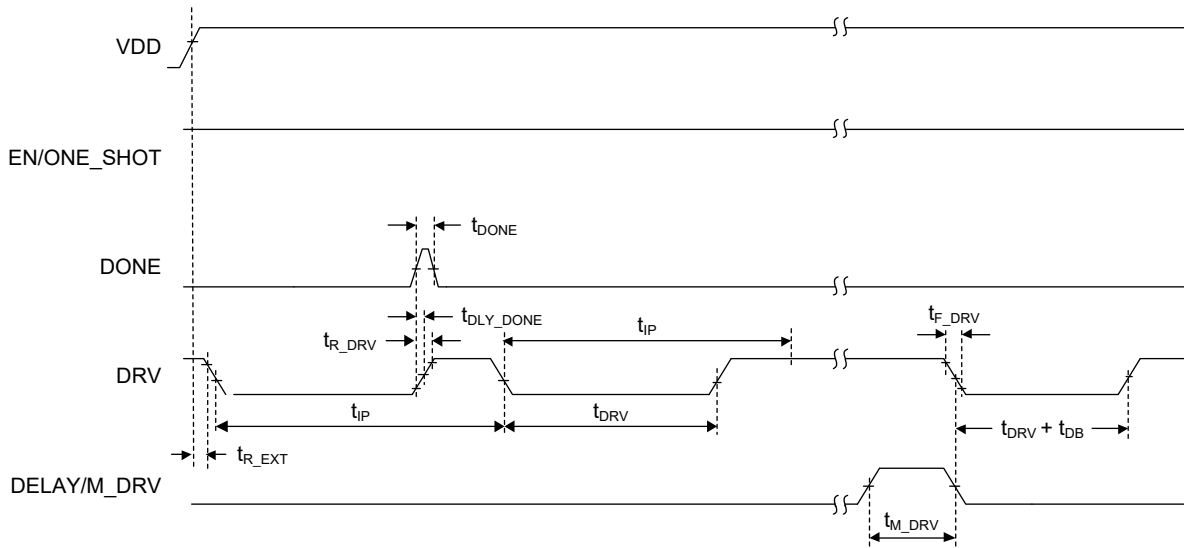

NOTE: It is recommended that the DONE signal must be given at least 200ns after the DRV falling edge to ensure the chip can correctly identify the DONE signal.

**Figure 2. Timing Diagram**

TYPICAL PERFORMANCE CHARACTERISTICS

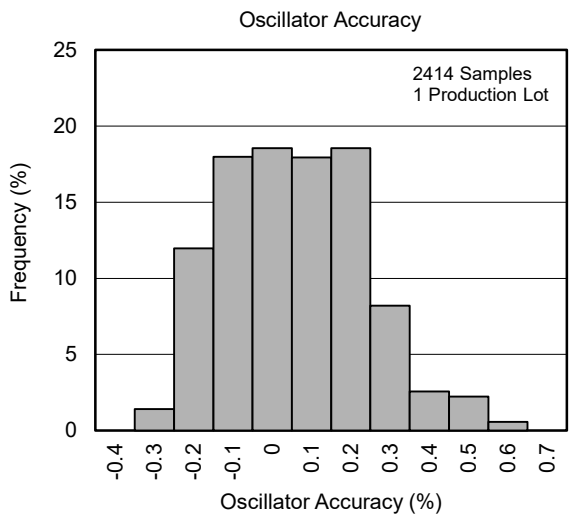
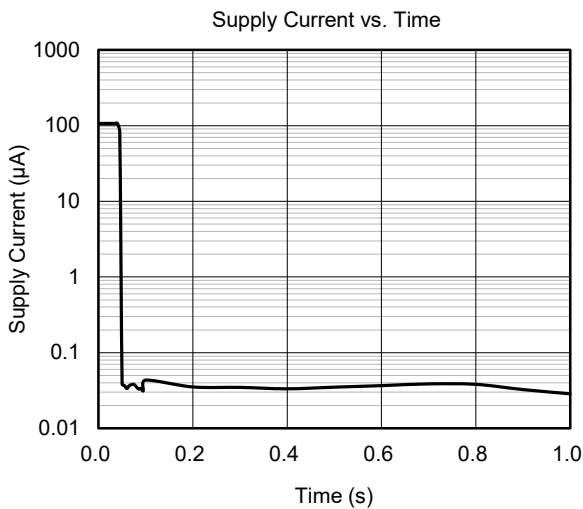
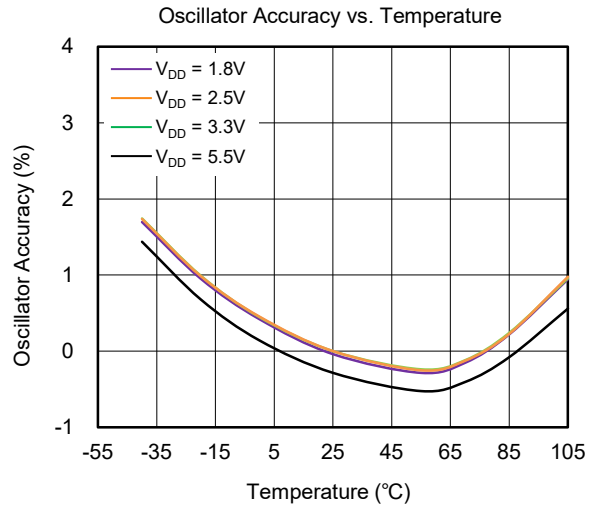
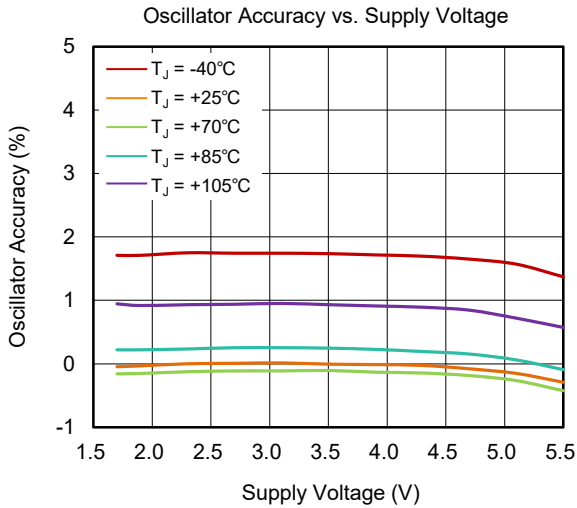
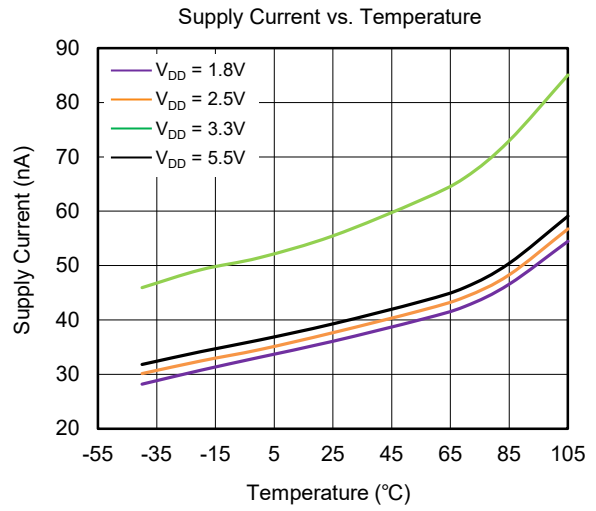
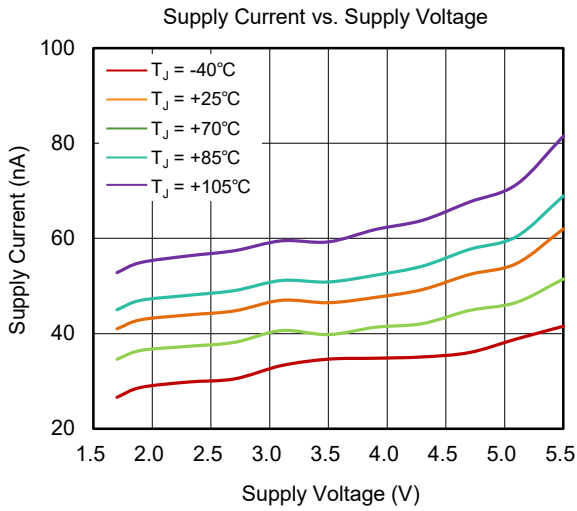

TYPICAL PERFORMANCE CHARACTERISTICS

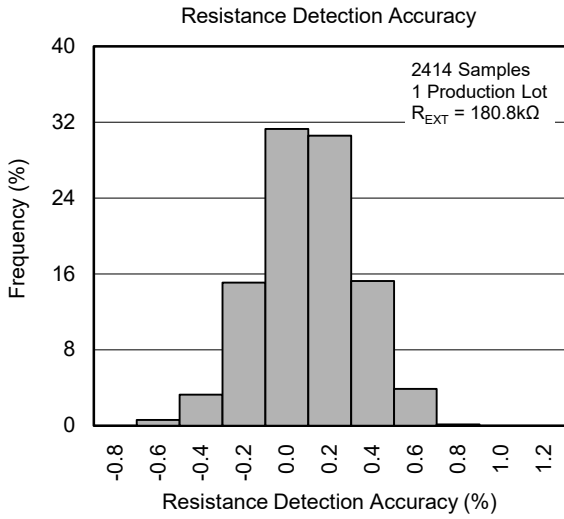
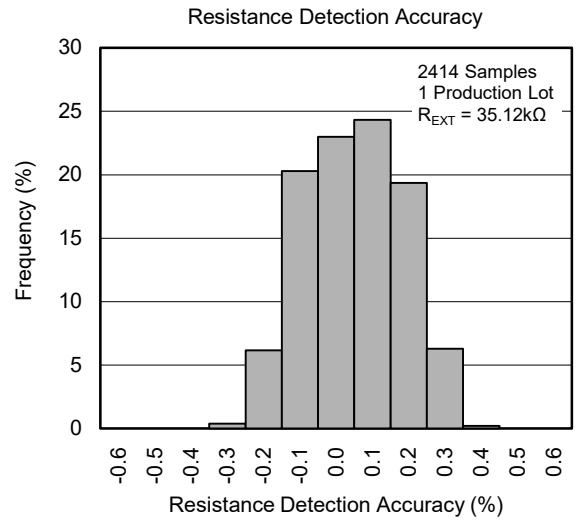
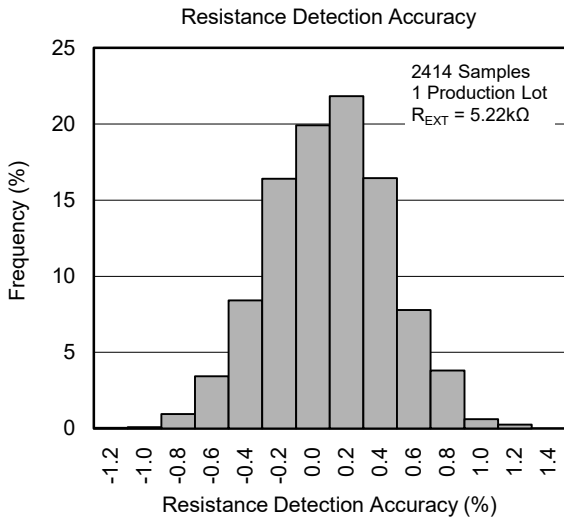

FUNCTIONAL BLOCK DIAGRAM

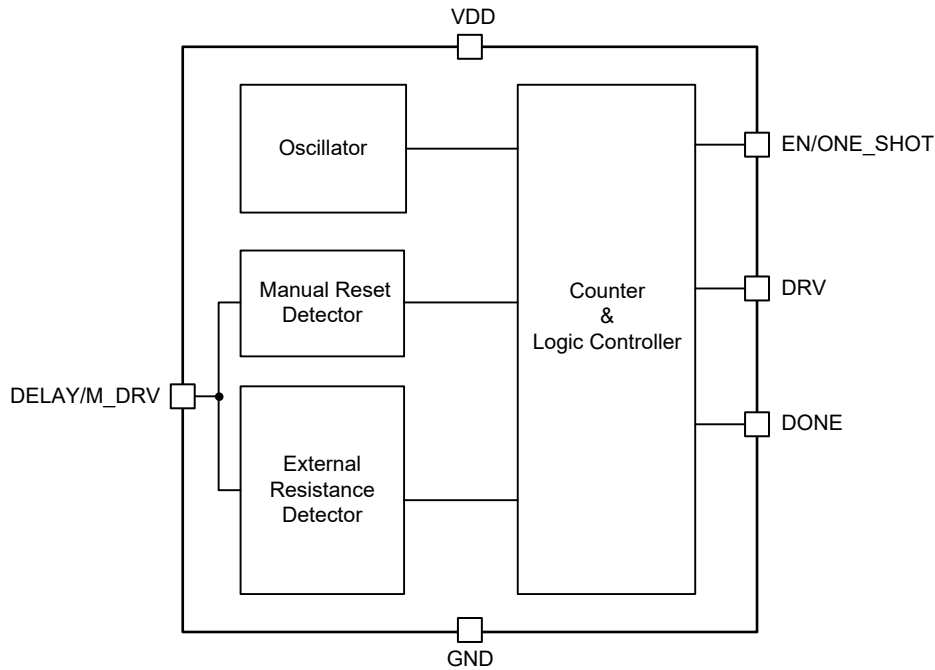

Figure 3. Block Diagram

DETAILED DESCRIPTION

Overview

The SGM855 is a nano-power system timer for power gating. It is designed for power-cycled applications with interval period varying from 100ms to 8200s.

When configured in timer mode (with EN/ONE\_SHOT pin set to high), the SGM855 periodically outputs a DRV signal to drive a MOSFET, thereby activating the microcontroller (µC). The operation follows this logic:

- If the µC sends a DONE signal back within the programmed timing window ( $t_{DRV}$ ), the SGM855 deactivates the µC immediately.
- If no valid DONE signal is received within  $t_{DRV}$ , the SGM855 keeps the µC powered for the full duration of  $t_{DRV}$ , ensuring sustained operation until the timeout.

When configured in one-shot mode (with EN/ONE\_SHOT pin set to low), the SGM855 outputs a DRV signal to drive the MOSFET only once.

Feature Description

The SGM855 enters timer mode or one-shot mode with different EN/ONE\_SHOT voltage. The DELAY/M\_DRV

pin is used to determine the timer interval period ( $t_{IP}$ ) in the startup procedure and manually power on the MOSFET by pulling high this pin to VDD.

DRV

The gate of the MOSFET is connected to the DRV pin. When DRV is set to low, the MOSFET is activated (turned on). The DRV pulse duration matches the programmed time interval minus a fixed 50ms. If a DONE signal is received from the µC before the remaining time (programmed interval minus 50ms) completes, the pulse ends early, immediately turning the MOSFET off. In the absence of a DONE signal within this adjusted timeframe, the DRV pin remains high for the final 50ms of the programmed interval, ensuring the MOSFET is fully turned off before the next cycle begins. The DRV pin defaults to high (MOSFET off) following resistance measurement in the beginning. The SGM855 initiates the DRV control signal at the start of each refreshed programmed time interval. Finally, manual power-on attempts are ignored while the DRV pin is low and the MOSFET is active.

DETAILED DESCRIPTION (continued)

DONE

The DONE is an input logic pin, and it is not allowed to be floating. And the SGM855 will recognize the rising edge of the DONE pulse. It is recommended to set the pulse width larger than 100ns. Besides, the SGM855 only recognizes the first DONE signal when multiple DONE signals are sent within one time interval of  $t_{IP}$ . Note that the DONE signal will not be recognized in the last 50ms of the current time interval. It is recommended that the DONE signal must be given at least 200ns after the DRV falling edge to ensure the chip can correctly identify the DONE signal.

If a valid DONE signal is recognized while the DRV is still asserted low, the DRV will go high as soon as possible.

Device Functional Modes

Startup

During startup, after power-on reset (POR), the SGM855 detects the resistance of the external resistor connected between DELAY/M\_RST pin and GND only one time and convert it to time interval period ( $t_{IP}$ ) within  $t_{R\_EXT}$ . After the resistance reading procedure, the SGM855 enters the timer mode or one-shot mode by the EN/ONE\_SHOT value. Wire EN/ONE\_SHOT to either GND or VDD based on the desired mode of operation.

Timer Mode

In timer mode (EN/ONE\_SHOT = high), the SGM855 generates periodic DRV pulses based on the programmed time interval. The duration of these DRV pulses is determined by receiving a DONE pulse from the  $\mu C$ . See Figure 4.

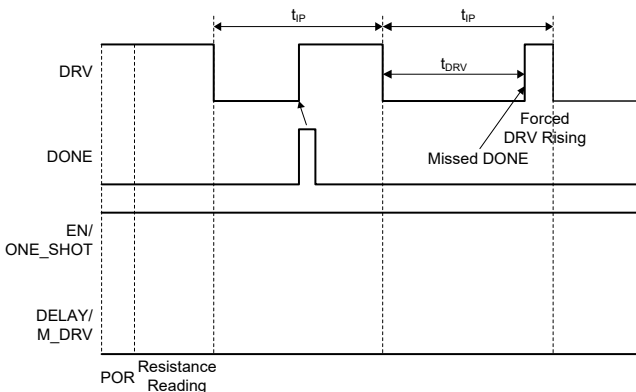

Figure 4. Startup Timer Mode

One-Shot Mode

During one-shot mode (EN/ONE\_SHOT = low), the SGM855 pulls down the DRV pin only once. The pulse length is determined by when the DONE pulse is released from the  $\mu C$  (See Figure 5). If no DONE pulse is received, the DRV pin is released at the final 50ms (See Figure 6).

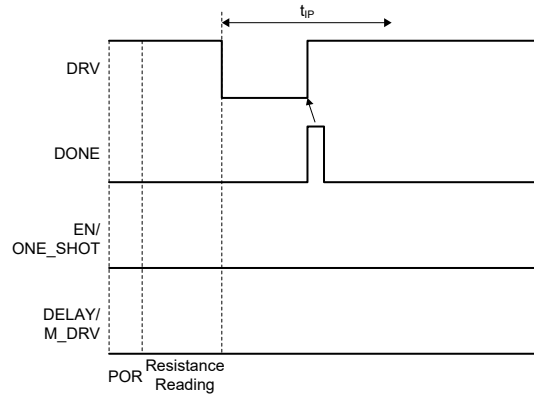

Figure 5. Startup One-Shot Mode (DONE Received within  $t_{IP}$ )

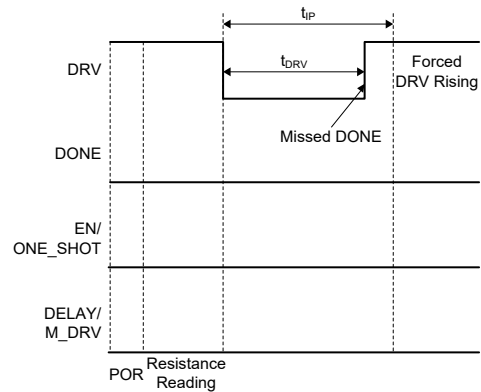

Figure 6. Startup One-Shot Mode (No DONE Received within  $t_{IP}$ )

Programming

Configuring the Time Interval with the DELAY/M\_DRV Pin

The time interval between two adjacent DRV pulses (measured at their falling edges in timer mode) is determined by an external resistance ( $R_{EXT}$ ) connected between the DELAY/M\_DRV pin and ground. This resistance must be selected within the range of 500 $\Omega$  to 180k $\Omega$ , and a minimum 1% precision resistor is recommended for accuracy. It is not allowed to connect a capacitor to DELAY/M\_RST pin. And it is also recommended that the trace between the resistor on DELAY/M\_RST pin and GND is as short as possible.

DETAILED DESCRIPTION (continued)

Besides, other interfering signals should be kept far away for good detection. For detailed guidance on calculating and setting the time interval using  $R_{EXT}$ , refer to the Time Interval Period Programming through External Resistance section.

Manual MOSFET Power-On Applied to the DELAY/M\_DRV Pin

When the DELAY/M\_DRV pin is connected to VDD, the SGM855 detects this action as a manual MOSFET power-on condition, which bypasses the programmed time interval setting. If a manual power-on signal is applied during POR or during the resistance-reading procedure, the ongoing reading process is immediately abandoned and will restart only after the DELAY/M\_DRV is released. A pulse on the DELAY/M\_DRV pin is recognized as a valid manual power-on command only if it persists for a minimum of 20ms (with a 30ms observation window to confirm the validity of the signal). The manual power-on function can be implemented using a momentary-action switch for tactile or mechanical control.

If the DRV is already low (MOSFET on), the manual MOSFET power-on is ignored.

DELAY/M\_DRV

Usually,  $R_{EXT}$  ranging from  $500\Omega$  to  $180k\Omega$  is recommended for the DELAY/M\_DRV pin to configure  $t_{IP}$ . In the POR and resistance reading procedure, the DELAY/M\_DRV pin is connected to an analog circuit by a mux. After that, the DELAY/M\_DRV pin is cut off to a digital circuit.

When a logic high signal is applied to the DELAY/M\_DRV pin, the SGM855 interprets this as a manual power-on command. The internal de-bounce circuitry, which is active on both rising and falling edges, ensures immunity to signal glitches on the DELAY/M\_DRV input.

To be a valid DELAY/M\_DRV, the high state must persist for over 20ms (with a 30ms observation window for validation). Once recognized, the DRV signal is asserted within the next 10ms, its duration determined by the programmed time interval minus 50ms, or truncated earlier if a DONE signal is received.

A valid manual power-on resets all internal counters, which restart only after the DELAY/M\_DRV transitions back to low. However, due to the asynchronous nature of the manual input and its variable duration, the low state for DRV may exhibit  $\pm 5ms$  uncertainty. Prolonged assertion of high on DELAY/M\_DRV forces the MOSFET on duration beyond the programmed interval. During this period, incoming DONE signals are ignored. Additionally, if the DRV is already low (indicating MOSFET active), subsequent manual power-on commands are suppressed until DRV returns to high.

Circuitry

The manual power-on is usually finished by a mechanical switch. There are two approaches to implement and the main difference is the current consumption.

When power efficiency is not the primary concern, a single-pole single-throw (SPST) switch configuration reduces costs. Here, the DELAY/M\_DRV pin connects to VDD with a resistor  $R_{EXT}$ . The resulting power-on current sourced from VDD can be determined by dividing VDD by  $R_{EXT}$  (See Figure 9).

When the lower current consumption is more significant, take a single-pole double-throw (SPDT) switch is more suitable (See Figure 10).

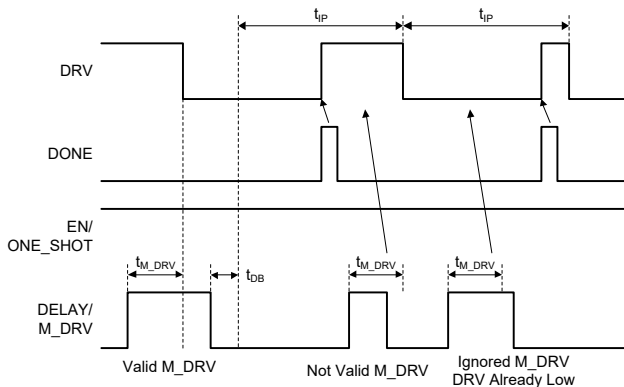

Figure 7. Manual MOSFET Power-On in Timer Mode

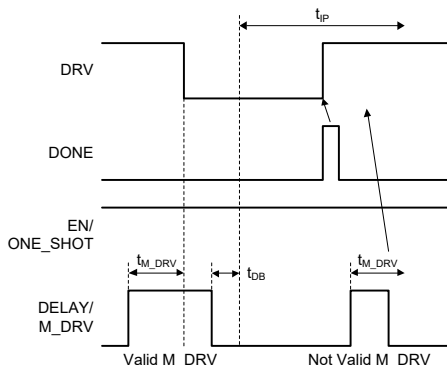

Figure 8. Manual MOSFET Power-On in One-Shot Mode

DETAILED DESCRIPTION (continued)

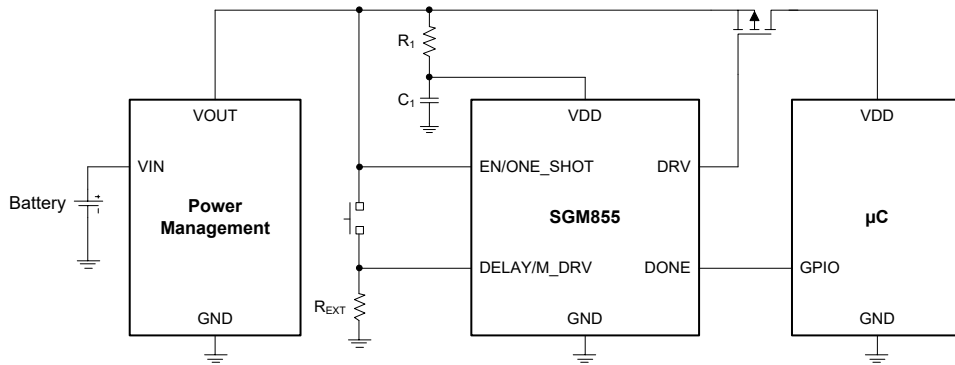

Figure 9. Manual MOSFET Power-On with SPST Switch

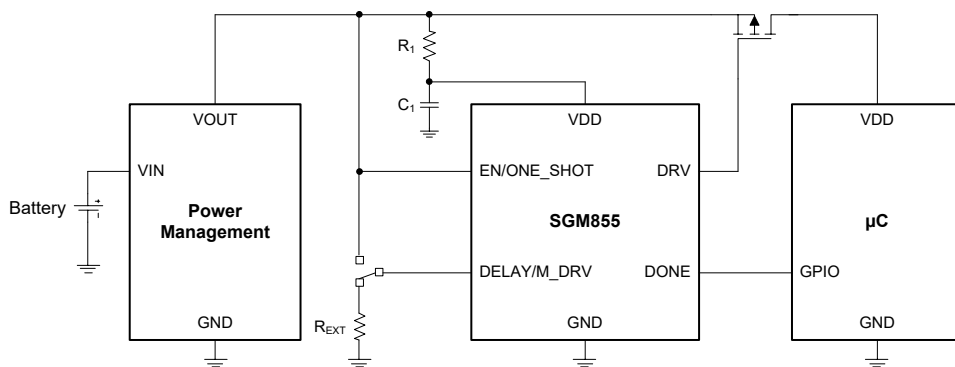

Figure 10. Manual MOSFET Power-On with SPDT Switch

Time Interval Period Programming through External Resistance

To set the time interval below 1 second, the external resistance  $R_{EXT}$  is selected according to Table 1.

Table 1. First 9 Time Intervals

| $t_P$ (ms) | Resistance (k $\Omega$ ) |
|------------|--------------------------|
| 100        | 0.5                      |
| 200        | 1                        |
| 300        | 1.5                      |
| 400        | 2                        |
| 500        | 2.5                      |
| 600        | 3                        |
| 700        | 3.5                      |
| 800        | 4                        |
| 900        | 4.5                      |

To set the time interval over 1 second, the external resistance  $R_{EXT}$  is selected according to Equation 1.

$$R_{EXT} = 5.2 \times T^{0.3932} \quad (1)$$

Users can also calculate the time interval period through Equation 2 (the inverse function of Equation 1).

$$T = 0.0153 \times R_{EXT}^{2.543} \quad (2)$$

where:

T is the desired time interval in seconds,  $R_{EXT}$  is the resistance value in k $\Omega$ .

Figure 11 is provided to facilitate customers to estimate the  $R_{EXT}$ .

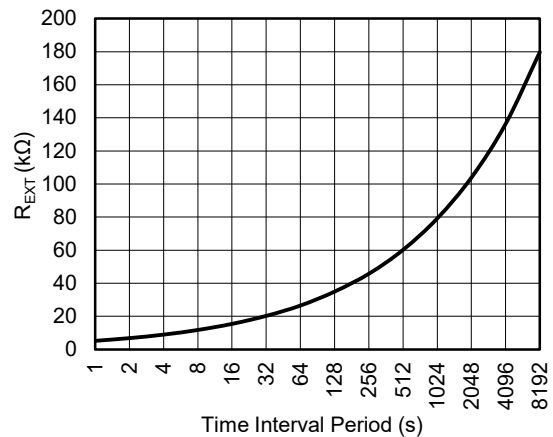

Figure 11.  $R_{EXT}$  vs. Time Interval Period

**DETAILED DESCRIPTION (continued)****Time Interval Period Setting Error**

The error of time interval period mainly consists of the following two parts: internal oscillator accuracy error and resistance detection error. It should be pointed out that this interval period setting error caused by the chip is discussed here, excluding the error caused by the external resistance. In order to reduce the error caused by external resistance, users should use high-precision resistance as much as possible. The examples below illustrate the procedure.

**Example 1:**

$V_{DD} = 2.5V$ ,  $T_J = +25^\circ C$ , and the target time interval  $t_{TARGET1}$  is 500ms. The required  $R_{EXT}$  is selected as 2.5k $\Omega$  according to Table 1.

Because the first 9 intervals are discrete intervals by multiples of 100ms, the resistance detecting tolerance is wide and can be neglected. The oscillator accuracy is  $\pm 1\%$  (If reliability drift is included, the accuracy is 2.1%), therefore, when  $R_{EXT}$  is 2.5k $\Omega$ , the actual time interval is:

$$\begin{aligned} 500 \times (1-1\%) \leq t_{IP}(\text{ms}) \leq 500 \times (1+1\%) \\ 495 \leq t_{IP}(\text{ms}) \leq 505 \end{aligned} \quad (3)$$

**Example 2:**

$V_{DD} = 2.5V$ ,  $T_J = +25^\circ C$ , and the target time interval  $t_{TARGET2}$  is 120s. The required  $R_{EXT}$  is calculated as 34k $\Omega$  according to Equation 1.

The resistance detection accuracy according to the Electrical Characteristics table is  $\pm 2.6\%$  approximately (if reliability drift is included, the accuracy is 3.5%), the approximate  $t_{IP}$  range excluding oscillator accuracy is:

$$\begin{aligned} 0.0153 \times [34 \times (1-2.6\%)]^{2.543} \leq t_{IP}(\text{s}) \\ \leq 0.0153 \times [34 \times (1+2.6\%)]^{2.543} \\ 112.2 \leq t_{IP}(\text{s}) \leq 128.1 \end{aligned} \quad (4)$$

The oscillator accuracy is  $\pm 1\%$ , so the final approximate  $t_{IP}$  range is:

$$\begin{aligned} 112.2 \times (1-1\%) \leq t_{IP}(\text{s}) \leq 128.1 \times (1+1.1\%) \\ 111.1 \leq t_{IP}(\text{s}) \leq 129.4 \end{aligned} \quad (5)$$

APPLICATION INFORMATION

In battery-powered systems, minimizing current consumption is critical. The SGM855 is specifically designed for periodic environmental monitoring applications. In these applications, conventional solutions often rely on a  $\mu\text{C}$ 's watchdog or internal timers for wake-up functions, where those components typically exhibit suboptimal power efficiency. By implementing periodic power gating of the  $\mu\text{C}$  or the entire system via the SGM855, the overall supply current can be reduced to mere tens of nA during inactive periods.

Typical Application

The SGM855 is ideal for low-power sensor nodes (e.g., humidity and temperature monitoring) requiring infrequent data transmission. In home environments, where temperature changes slowly, measurements and data transfers can be executed at very low rates (e.g., every 30 seconds). The SGM855 enables full shutdown of the RF microcontroller during inactive periods, dramatically extending battery life compared to traditional designs.

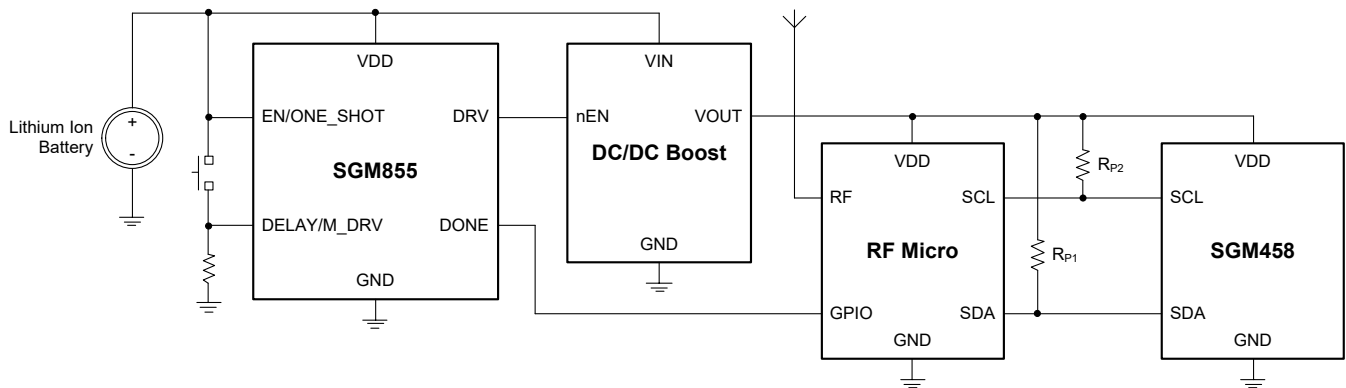

Figure 12. Sensor Node

Design Requirements

The primary focus for design is minimizing power consumption to extend battery life to years, leveraging the capability of SGM855 to fully shut down the RF microcontroller during inactive periods. Since environmental data (e.g., temperature/humidity) only requires 30s to 60s sampling intervals, this "deep-off" mode eliminates standby currents, making the SGM855 indispensable for ultra-low power IoT applications.

Detailed Design Procedure

Under strict battery-life constraints, the design mandates the use of ultra-low power voltage regulators and low-leakage MOSFETs to enable precise  $\mu\text{C}$  power gating. The initial design phase requires a detailed power-consumption analysis across all operational modes of each component. For instance, the sensor measurement mode activates the RF microcontroller for normal operation and data transmission. By strategically selecting the duration of each operational mode and balancing measurement or transmission intervals (e.g., 30s to 60s) with extended low-power

states, the system can adhere to application requirements while maximizing battery longevity.

Application Curve

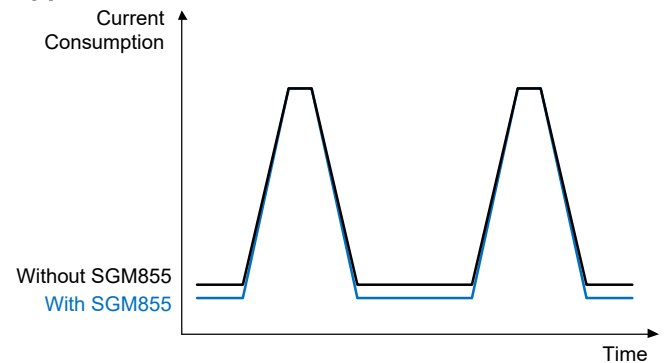

Figure 13. Effect of SGM855 on Current Consumption

Power Supply Recommendations

The SGM855 requires a voltage supply within 1.8V and 5.5V. To immune the power supply noise, an RC low-pass filter is strongly recommended as Figure 1 shows. The recommended resistance value is 10 $\Omega$ , and the ceramic X7R capacitor value is 1 $\mu\text{F}$ .

**APPLICATION INFORMATION (continued)**

**Layout**

It is not allowed to connect a capacitor to DELAY/M\_RST pin. Because of the DELAY/M\_DRV pin is sensitive to parasitic capacitance when detecting the resistance, it is recommended that the trace between the external resistor on this pin and GND track is as short as possible.

Make sure that the DRV pin of SGM855 is close to the gate of the MOSFET in order to reduce the parasitic capacitance and improve the signal integrity.

Keep EN/ONE\_SHOT trace as close as possible to VDD or GND.

**REVISION HISTORY**

NOTE: Page numbers for previous revisions may differ from page numbers in the current version.

| <b>JANUARY 2026 – REV.A to REV.A.1</b>                | <b>Page</b> |
|---|-------------|
| Updated Detailed Description section .....            | 12          |
| <b>Changes from Original to REV.A (APRIL 2025)</b>    | <b>Page</b> |
| Changed from product preview to production data ..... | All         |

PACKAGE OUTLINE DIMENSIONS

SOT-23-6

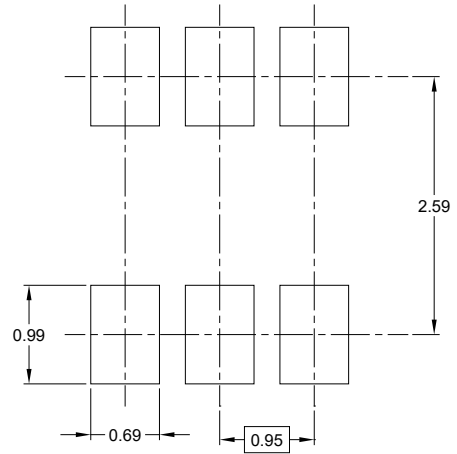
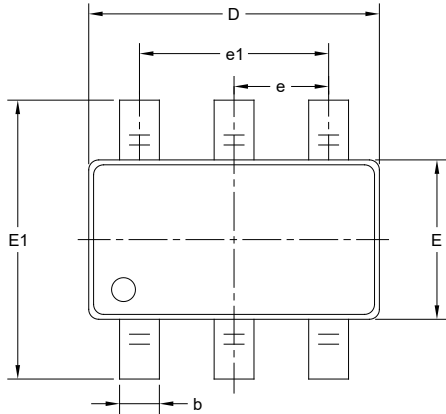

RECOMMENDED LAND PATTERN (Unit: mm)

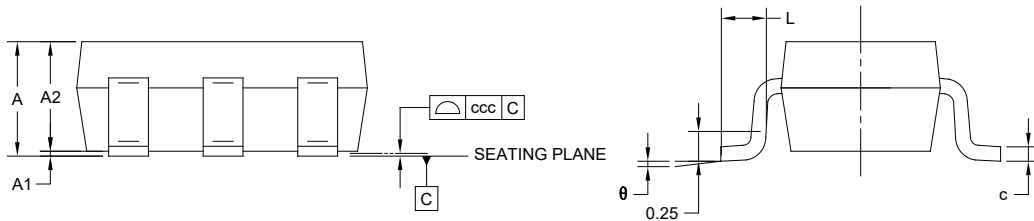

| Symbol   | Dimensions In Millimeters |     |       |
|----------|---------------------------|-----|-------|
|          | MIN                       | NOM | MAX   |
| A        | -                         | -   | 1.450 |
| A1       | 0.000                     | -   | 0.150 |
| A2       | 0.900                     | -   | 1.300 |
| b        | 0.300                     | -   | 0.500 |
| c        | 0.080                     | -   | 0.220 |
| D        | 2.750                     | -   | 3.050 |
| E        | 1.450                     | -   | 1.750 |
| E1       | 2.600                     | -   | 3.000 |
| e        | 0.950 BSC                 |     |       |
| e1       | 1.900 BSC                 |     |       |
| L        | 0.300                     | -   | 0.600 |
| $\theta$ | 0°                        | -   | 8°    |
| ccc      | 0.100                     |     |       |

NOTES:

1. This drawing is subject to change without notice.
2. The dimensions do not include mold flashes, protrusions or gate burrs.
3. Reference JEDEC MO-178.

TAPE AND REEL INFORMATION

REEL DIMENSIONS

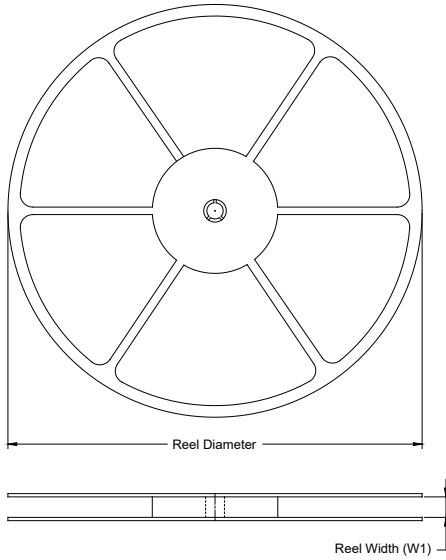

TAPE DIMENSIONS

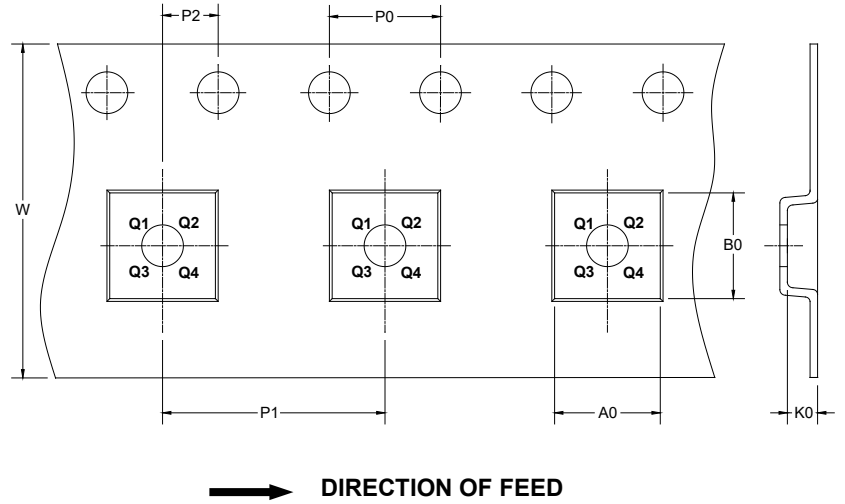

NOTE: The picture is only for reference. Please make the object as the standard.

KEY PARAMETER LIST OF TAPE AND REEL

| Package Type | Reel Diameter | Reel Width W1 (mm) | A0 (mm) | B0 (mm) | K0 (mm) | P0 (mm) | P1 (mm) | P2 (mm) | W (mm) | Pin1 Quadrant |
|--------------|---------------|--------------------|---------|---------|---------|---------|---------|---------|--------|---------------|
| SOT-23-6     | 7"            | 9.5                | 3.23    | 3.17    | 1.37    | 4.0     | 4.0     | 2.0     | 8.0    | Q3            |

DD0001

# PACKAGE INFORMATION

## CARTON BOX DIMENSIONS

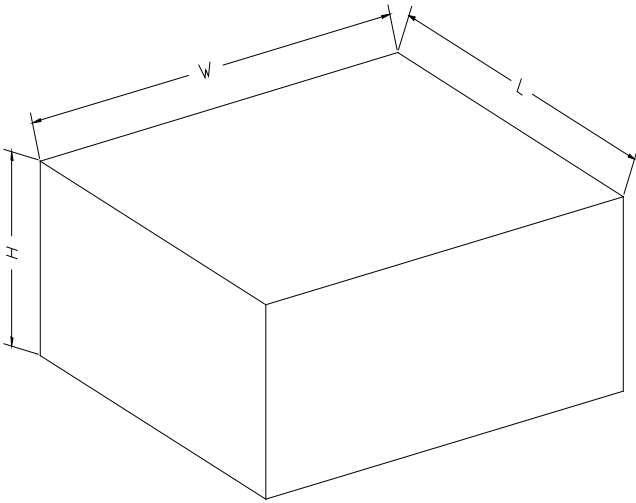

NOTE: The picture is only for reference. Please make the object as the standard.

## KEY PARAMETER LIST OF CARTON BOX

| Reel Type   | Length (mm) | Width (mm) | Height (mm) | Pizza/Carton |
|-------------|-------------|------------|-------------|--------------|
| 7" (Option) | 368         | 227        | 224         | 8            |
| 7"          | 442         | 410        | 224         | 18           |

D00002