



# SGM845xQ

## -16V to 80V, 1.3MHz, Automotive High-Precision Current Sense Amplifier with Open-Drain Comparator and Reference

### GENERAL DESCRIPTION

The SGM845xQ is a high-precision current sense amplifier with wide common-mode range from -16V to 80V to measure voltage drops across shunt resistors, irrespective of the supply voltage. The small gain error ( $\pm 0.03\%$ , TYP), low offset voltage ( $\pm 100\mu\text{V}$ , TYP), and high DC CMRR (130dB, TYP) make it capable for high precision current measurements. The device has a high signal bandwidth of 1.3MHz, which is designed for high-voltage high-speed applications such as rapid over-current protection. The SGM845xQ includes an open-drain comparator and a 0.6V internal reference. The current trip point is adjustable via two external resistors. The comparator also features a latching function that can be overridden by grounding the nRESET pin or leaving it open.

Functioning from a single supply voltage between 2.7V and 20V, the SGM845xQ consumes low supply current of 1.5mA. It is offered in five different gain settings: 20V/V, 50V/V, 100V/V, 200V/V, and 500V/V. These gain options cater to a diverse range of current-sensing applications, covering a broad dynamic range.

The device is AEC-Q100 qualified (Automotive Electronics Council (AEC) standard Q100 Grade 1) and it is suitable for automotive applications.

The SGM845xQ is available in a Green MSOP-8 package.

### FEATURES

- AEC-Q100 Qualified for Automotive Applications Device Temperature Grade 1  
 $T_A = -40^\circ\text{C}$  to  $+125^\circ\text{C}$
- Wide Common-Mode Voltage Range:
  - ◆ Operational Voltage: -16V to 80V
  - ◆ Survival Voltage: -20V to 85V
- High Signal Bandwidth: 1.3MHz
- Slew Rate: 8V/ $\mu\text{s}$
- Excellent CMRR: 130dB
- Gain Error Accuracy:  $\pm 0.03\%$  (TYP),  $\pm 0.65\%$  (MAX)
- Offset Voltage Accuracy:  $\pm 100\mu\text{V}$  (TYP),  $\pm 600\mu\text{V}$  (MAX)
- On-Board Open-Drain Comparator
- Internal Comparator Voltage Reference: 0.6V
- Propagation Delay Time: 1 $\mu\text{s}$
- Comparator with Latching Function
- Available Gains:
  - ◆ SGM845AQ: 20V/V
  - ◆ SGM845BQ: 50V/V
  - ◆ SGM845CQ: 100V/V
  - ◆ SGM845DQ: 200V/V
  - ◆ SGM845EQ: 500V/V
- Available in a Green MSOP-8 Package

### APPLICATIONS

Electric Power Steering (EPS)  
eTurbo/Charger  
Starter/Generator  
Brake System  
Regenerative Braking

### SIMPLIFIED SCHEMATIC

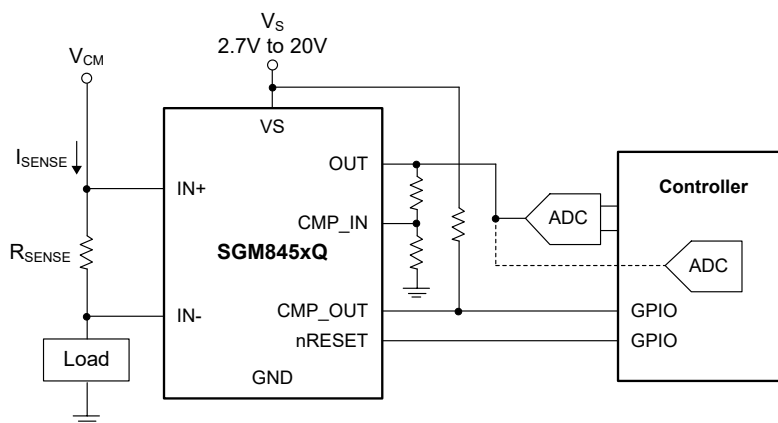

Figure 1. Simplified Schematic

# -16V to 80V, 1.3MHz, High-Precision Current Sense Amplifier with Open-Drain Comparator and Reference

## SGM845xQ

### PACKAGE/ORDERING INFORMATION

MODEL	PACKAGE DESCRIPTION	SPECIFIED TEMPERATURE RANGE	ORDERING NUMBER	PACKAGE MARKING	PACKING OPTION
SGM845AQ	MSOP-8	-40°C to +125°C	SGM845AQMS8G/TR	2A1MS8 XXXXX	Tape and Reel, 4000
SGM845BQ	MSOP-8	-40°C to +125°C	SGM845BQMS8G/TR	2A2MS8 XXXXX	Tape and Reel, 4000
SGM845CQ	MSOP-8	-40°C to +125°C	SGM845CQMS8G/TR	2A3MS8 XXXXX	Tape and Reel, 4000
SGM845DQ	MSOP-8	-40°C to +125°C	SGM845DQMS8G/TR	2A4MS8 XXXXX	Tape and Reel, 4000
SGM845EQ	MSOP-8	-40°C to +125°C	SGM845EQMS8G/TR	2A5MS8 XXXXX	Tape and Reel, 4000

### MARKING INFORMATION

NOTE: XXXXX = Date Code, Trace Code and Vendor Code.

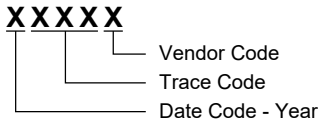

Green (RoHS & HSF): SG Micro Corp defines "Green" to mean Pb-Free (RoHS compatible) and free of halogen substances. If you have additional comments or questions, please contact your SGMICRO representative directly.

### ABSOLUTE MAXIMUM RATINGS

Supply Voltage, $V_S$ .....	-0.3V to 22V
Analog Inputs	
Differential $V_{IN+} - V_{IN-}$ .....	-60V to 60V
$V_{IN+}$ , $V_{IN-}$ (with respect to GND).....	-20V to 85V
Analog Output Voltage, $V_{OUT}$ .....	GND - 0.3V to $V_S + 0.3V$
Comparator Reset Pin Voltage .....	GND - 0.3V to $V_S + 0.3V$
Comparator Analog Input Voltage .....	.....
.....	GND - 0.3V to MIN (5.5V, $V_S$ )
Comparator Output Voltage .....	GND - 0.3V to 22V
Input Current into Any Pin.....	5mA
Package Thermal Resistance	
MSOP-8, $\theta_{JA}$ .....	136.5°C/W
MSOP-8, $\theta_{JB}$ .....	83.2°C/W
MSOP-8, $\theta_{JC}$ .....	49.9°C/W
Junction Temperature.....	+150°C
Storage Temperature Range .....	-65°C to +150°C
Lead Temperature (Soldering, 10s).....	+260°C
ESD Susceptibility <sup>(1) (2)</sup>	
HBM.....	±6000V
CDM .....	±2000V

#### NOTES:

- For human body model (HBM), all pins comply with AEC-Q100-002 specification.
- For charged device model (CDM), all pins comply with AEC-Q100-011 specification.

### RECOMMENDED OPERATING CONDITIONS

Common-Mode Input Range, $V_{CM}$ .....	-16V to 80V (48V, TYP)
Operating Supply Voltage, $V_S$ .....	2.7V to 20V (5V, TYP)
Differential Sense Input Range, $V_{SENSE}$ .....	0V to $V_S/G$
Operating Ambient Temperature Range .....	-40°C to +125°C
Operating Junction Temperature Range .....	-40°C to +125°C

### OVERSTRESS CAUTION

Stresses beyond those listed in Absolute Maximum Ratings may cause permanent damage to the device. Exposure to absolute maximum rating conditions for extended periods may affect reliability. Functional operation of the device at any conditions beyond those indicated in the Recommended Operating Conditions section is not implied.

### ESD SENSITIVITY CAUTION

This integrated circuit can be damaged if ESD protections are not considered carefully. SGMICRO recommends that all integrated circuits be handled with appropriate precautions. Failure to observe proper handling and installation procedures can cause damage. ESD damage can range from subtle performance degradation to complete device failure. Precision integrated circuits may be more susceptible to damage because even small parametric changes could cause the device not to meet the published specifications.

### DISCLAIMER

SG Micro Corp reserves the right to make any change in circuit design, or specifications without prior notice.

**PIN CONFIGURATION**

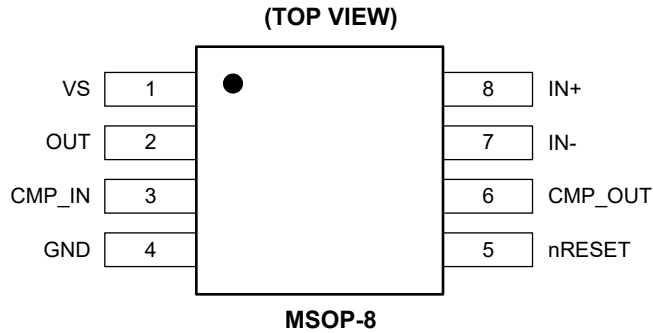

**PIN DESCRIPTION**

PIN	NAME	TYPE	FUNCTION
1	VS	P	2.7V to 20V Power Supply. Place a 0.1µF capacitor from VS pin to GND close to the device.
2	OUT	O	Output Voltage.
3	CMP_IN	I	Comparator Input.
4	GND	G	Ground.
5	nRESET	I	Active Low Comparator Reset Pin. Setting it low activates transparent mode, and setting it high activates latch mode.
6	CMP_OUT	O	Comparator Output. When nRESET is high, the comparator latches high.
7	IN-	I	Negative Sense Input Connection of Shunt Resistor. Connect it to the load side of sense resistor for high-side applications. Connect it to the ground side of sense resistor for low-side applications.
8	IN+	I	Positive Sense Input Connection of Shunt Resistor. Connect it to the bus-voltage side of sense resistor for high-side applications. Connect it to the load side of sense resistor for low-side applications.

NOTE: I = input, O = output, P = power, G = ground.

# -16V to 80V, 1.3MHz, High-Precision Current Sense SGM845xQ Amplifier with Open-Drain Comparator and Reference

## ELECTRICAL CHARACTERISTICS

( $V_S = 5.0V$ ,  $V_{SENSE} = V_{IN+} - V_{IN-} = 0.5V/Gain$ ,  $V_{CM} = V_{IN-} = 48V$ , and  $R_{PULL-UP} = 5.1k\Omega$  connected from  $CMP\_OUT$  to  $V_S$ ,  $T_A = -40^\circ C$  to  $+125^\circ C$ , typical values are measured at  $T_A = +25^\circ C$ , unless otherwise noted.)

PARAMETER	SYMBOL	CONDITIONS	MIN	TYP	MAX	UNITS	
<b>Power Supply</b>							
Supply Voltage Range	$V_S$		2.7		20	V	
Quiescent Current	$I_Q$	$T_A = +25^\circ C$		1.5	2.0	mA	
		$T_A = -40^\circ C$ to $+125^\circ C$			2.2		
<b>Input</b>							
Common-Mode Input Range	$V_{CM}$		-16		80	V	
Common-Mode Rejection Ratio	CMRR	SGM845AQ, $V_{IN+} = -16V$ to $80V$ , $T_A = -40^\circ C$ to $+125^\circ C$	108	130		dB	
		SGM845BQ/CQ/DQ/EQ, $V_{IN+} = -16V$ to $80V$ , $T_A = -40^\circ C$ to $+125^\circ C$	118	134			
		$f = 50kHz$		70			
Offset Voltage, RTI <sup>(1)</sup>	$V_{OS}$	SGM845AQ	$T_A = +25^\circ C$		$\pm 100$	$\pm 400$	$\mu V$
			$T_A = -40^\circ C$ to $+125^\circ C$			$\pm 600$	
		SGM845BQ	$T_A = +25^\circ C$		$\pm 50$	$\pm 300$	
			$T_A = -40^\circ C$ to $+125^\circ C$			$\pm 400$	
		SGM845CQ/DQ/EQ	$T_A = +25^\circ C$		$\pm 50$	$\pm 200$	
			$T_A = -40^\circ C$ to $+125^\circ C$			$\pm 300$	
Power-Supply Rejection Ratio, RTI	PSRR	SGM845AQ, $V_S = 2.7V$ to $20V$ , $T_A = -40^\circ C$ to $+125^\circ C$		$\pm 3$	$\pm 20$	$\mu V/V$	
		SGM845BQ/CQ/DQ/EQ, $V_S = 2.7V$ to $20V$ , $T_A = -40^\circ C$ to $+125^\circ C$		$\pm 1$	$\pm 10$		
Input Bias Current	$I_B$	$I_{B+}, I_{B-}, V_{SENSE} = 0mV$	$T_A = +25^\circ C$		$\pm 0.1$	$\pm 0.5$	$\mu A$
			$T_A = -40^\circ C$ to $+125^\circ C$			$\pm 2$	
<b>Output</b>							
Gain	G	SGM845AQ		20		V/V	
		SGM845BQ		50			
		SGM845CQ		100			
		SGM845DQ		200			
		SGM845EQ		500			
Gain Error	GERR	SGM845AQ/BQ/CQ/DQ, $GND + 100mV \leq V_{OUT} \leq V_S - 200mV$	$T_A = +25^\circ C$	$\pm 0.03$	$\pm 0.2$	%	
			$T_A = -40^\circ C$ to $+125^\circ C$				$\pm 0.4$
		SGM845EQ, $GND + 100mV \leq V_{OUT} \leq V_S - 200mV$	$T_A = +25^\circ C$	$\pm 0.03$	$\pm 0.3$		
			$T_A = -40^\circ C$ to $+125^\circ C$				$\pm 0.65$
Nonlinearity Error	$NL_{ERR}$	$GND + 100mV \leq V_{OUT} \leq V_S - 200mV$		$\pm 0.01$		%	
Maximum Capacitive Load		No sustained oscillation, no isolation resistor		500		pF	
<b>Voltage Output</b>							
Swing to $V_S$ (Power Supply Rail)	$V_{SP}$	$R_{LOAD} = 10k\Omega$ to $GND$		$V_S - 50$	$V_S - 150$	mV	
Swing to $GND$	$V_{SN}$	$R_{LOAD} = 10k\Omega$ to $GND$ , $V_{SENSE} = 0mV$		$V_{GND} + 5$	$V_{GND} + 20$	mV	
<b>Frequency Response</b>							
Bandwidth	BW	SGM845AQ, $C_{LOAD} = 5pF$ , $V_{SENSE} = 200mV$		1300		kHz	
		SGM845BQ, $C_{LOAD} = 5pF$ , $V_{SENSE} = 80mV$		1300			
		SGM845CQ, $C_{LOAD} = 5pF$ , $V_{SENSE} = 40mV$		1000			
		SGM845DQ, $C_{LOAD} = 5pF$ , $V_{SENSE} = 20mV$		400			
		SGM845EQ, $C_{LOAD} = 5pF$ , $V_{SENSE} = 8mV$		400			

# -16V to 80V, 1.3MHz, High-Precision Current Sense Amplifier with Open-Drain Comparator and Reference

## SGM845xQ

### ELECTRICAL CHARACTERISTICS (continued)

( $V_S = 5.0V$ ,  $V_{SENSE} = V_{IN+} - V_{IN-} = 0.5V/Gain$ ,  $V_{CM} = V_{IN-} = 48V$ , and  $R_{PULL-UP} = 5.1k\Omega$  connected from  $CMP\_OUT$  to  $V_S$ ,  $T_A = -40^\circ C$  to  $+125^\circ C$ , typical values are measured at  $T_A = +25^\circ C$ , unless otherwise noted.)

PARAMETER	SYMBOL	CONDITIONS	MIN	TYP	MAX	UNITS	
Slew Rate	SR	Rising edge		8		V/ $\mu s$	
Settling Time	$t_s$	$V_{OUT} = 4V \pm 0.1V$ step, output settles to 0.5%		6		$\mu s$	
		$V_{OUT} = 4V \pm 0.1V$ step, output settles to 5%		1		$\mu s$	
<b>Noise</b>							
Voltage Noise Density	$V_{EN}$			201		nV/ $\sqrt{Hz}$	
<b>Comparator</b>							
Alert Threshold	$V_{TH}$	$T_A = +25^\circ C$	585	600	615	mV	
		$T_A = -40^\circ C$ to $+125^\circ C$	580		620		
Hysteresis				8		mV	
Small-Signal Propagation Delay	$t_p$	Comparator input overdrive = 20mV		1		$\mu s$	
Slew-Rate-Limited Propagation Delay		$V_{OUT}$ step = 0.5V to 4.5V, $V_{LIMIT}^{(2)} = 4V$		1		$\mu s$	
Input Bias Current, $CMP\_IN$ Pin	$I_{BCMP\_IN}$	$V_{CMP\_IN} = 0.4V$ to $1.2V$	$T_A = +25^\circ C$	$\pm 5$	$\pm 20$	nA	
			$T_A = -40^\circ C$ to $+125^\circ C$				250
High-Level Leakage Current	$I_{LKG}$	$V_{CMP\_OUT} = V_S$		0.01	1	$\mu A$	
Low-Level Output Voltage	$V_{OL}$	$I_{OL} = 2.35mA$	$T_A = +25^\circ C$		120	200	mV
			$T_A = -40^\circ C$ to $+125^\circ C$				
nRESET High-Level Input Voltage Threshold <sup>(3)</sup>	$V_{IH}$		1.3			V	
nRESET Low-Level Input Voltage Threshold <sup>(3)</sup>	$V_{IL}$				0.4	V	
Minimum nRESET Pulse Width				40		ns	
nRESET Propagation Delay				40		ns	

**NOTES:**

1. RTI = referred-to-input.
2.  $V_{LIMIT}$  represents  $V_{OUT}$  when the over-current threshold, determined by external resistors, is reached.
3. The nRESET features an internal 2M $\Omega$  pull-down resistor typically. Leaving nRESET open results in a low state and ensures transparent comparator operation.

# -16V to 80V, 1.3MHz, High-Precision Current Sense SGM845xQ Amplifier with Open-Drain Comparator and Reference

## TYPICAL PERFORMANCE CHARACTERISTICS

$T_A = +25^\circ\text{C}$ ,  $V_S = 5\text{V}$ ,  $V_{\text{SENSE}} = V_{\text{IN}+} - V_{\text{IN}-} = 0.5\text{V}/\text{Gain}$ ,  $V_{\text{CM}} = V_{\text{IN}-} = 48\text{V}$ , and  $R_{\text{PULL-UP}} = 5.1\text{k}\Omega$ , unless otherwise noted.

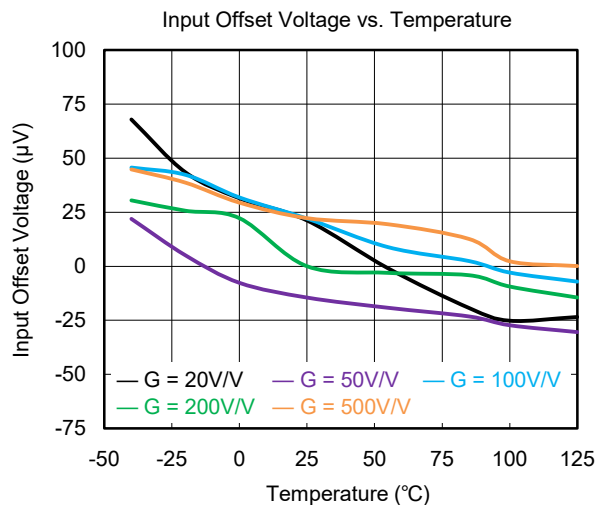
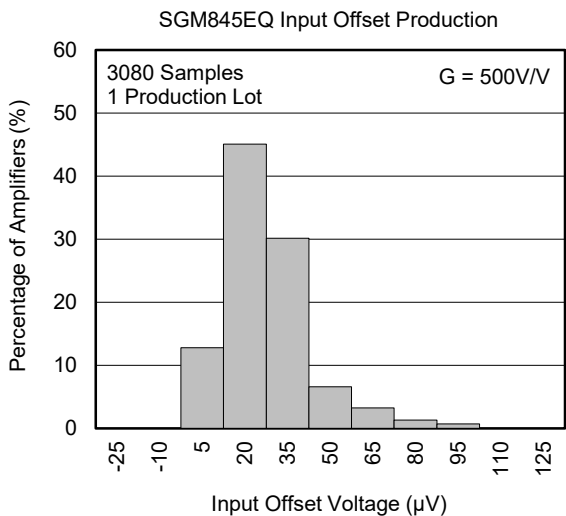
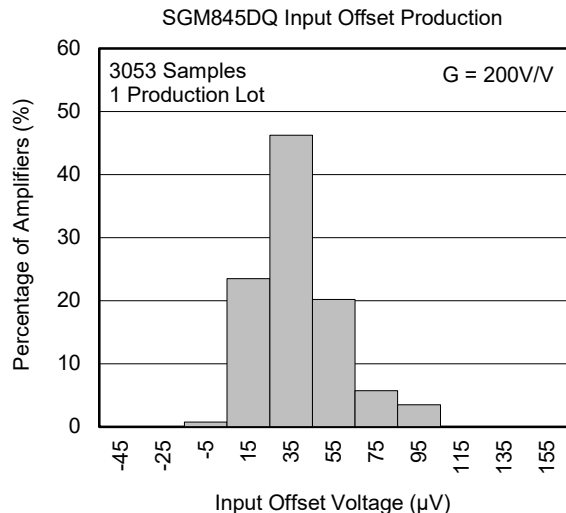
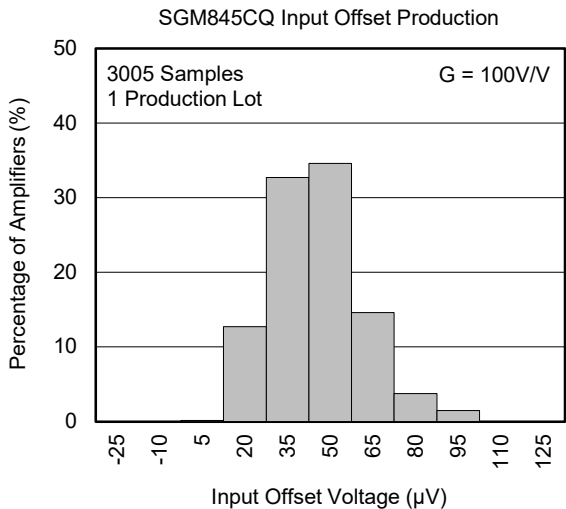
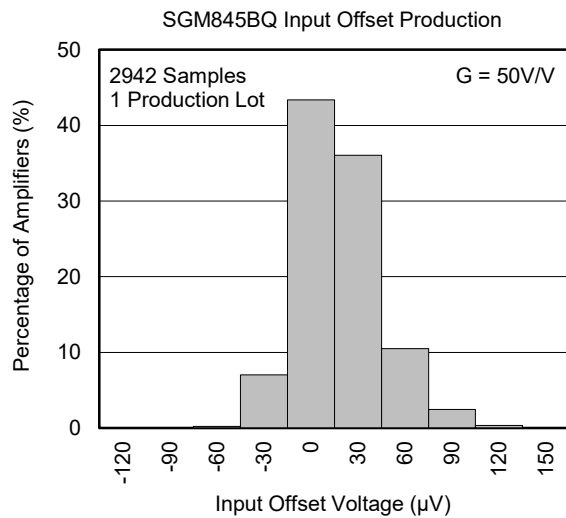
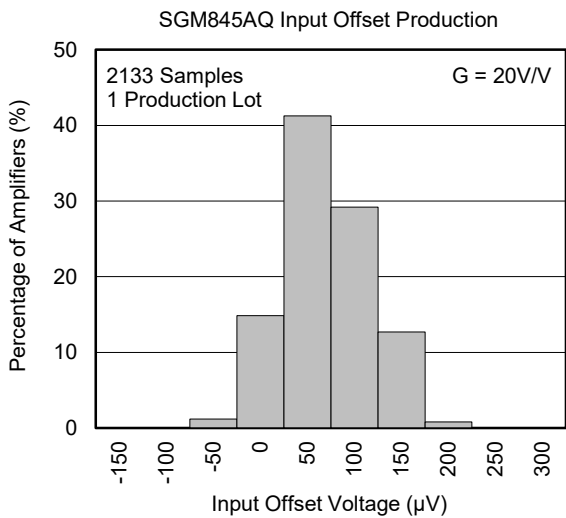

# -16V to 80V, 1.3MHz, High-Precision Current Sense Amplifier with Open-Drain Comparator and Reference

## SGM845xQ

### TYPICAL PERFORMANCE CHARACTERISTICS (continued)

$T_A = +25^\circ\text{C}$ ,  $V_S = 5\text{V}$ ,  $V_{\text{SENSE}} = V_{\text{IN}+} - V_{\text{IN}-} = 0.5\text{V}/\text{Gain}$ ,  $V_{\text{CM}} = V_{\text{IN}-} = 48\text{V}$ , and  $R_{\text{PULL-UP}} = 5.1\text{k}\Omega$ , unless otherwise noted.

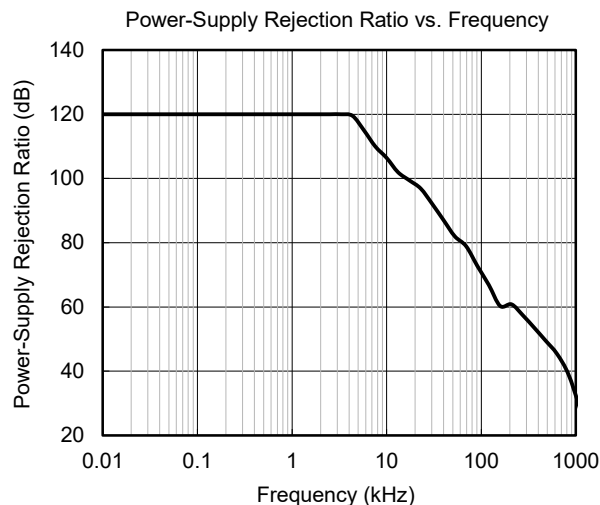
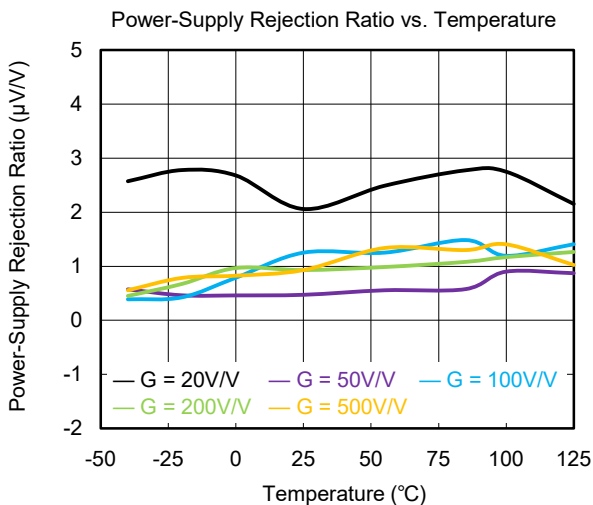
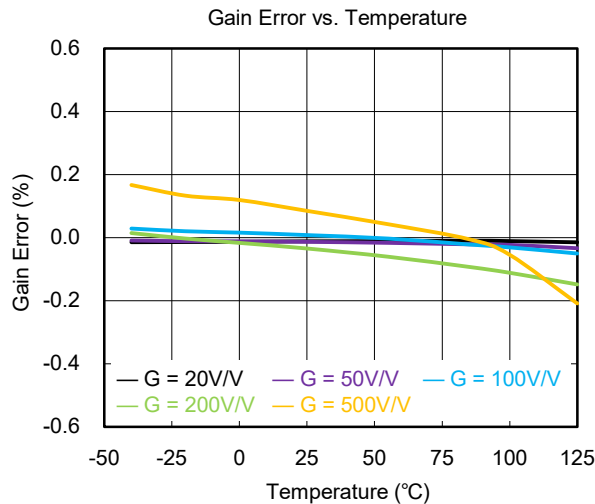
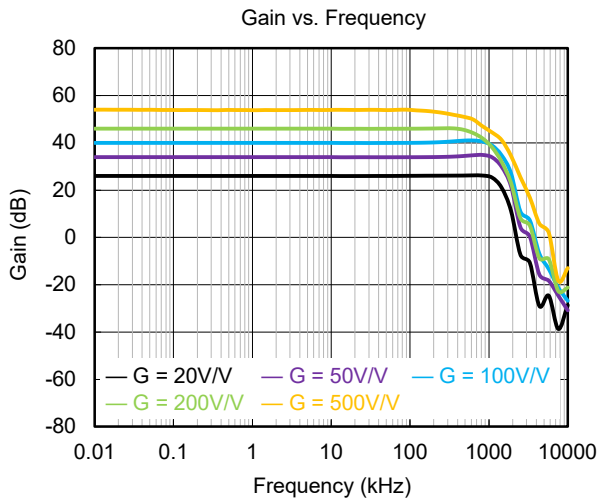
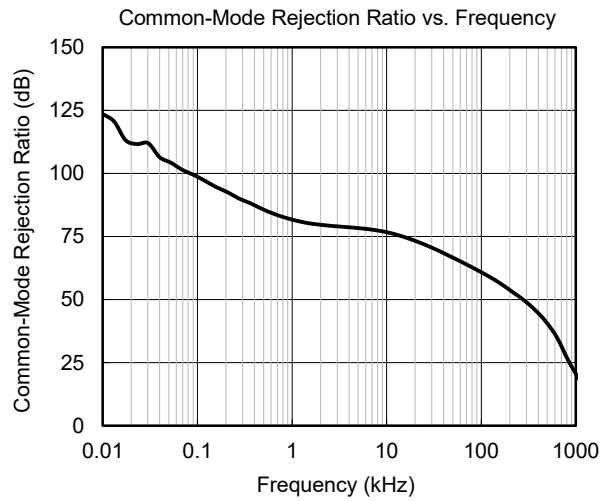
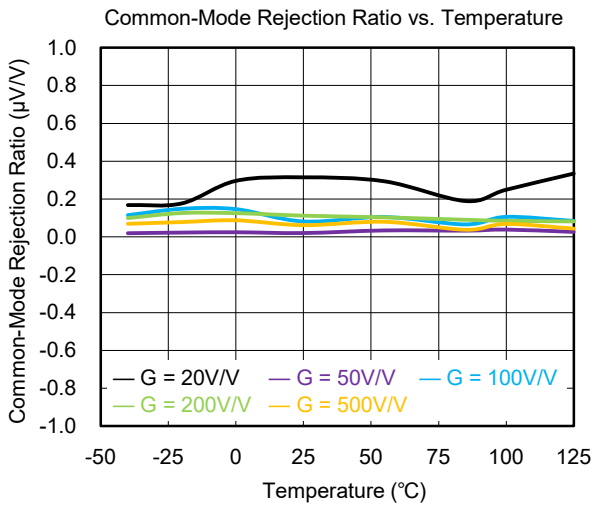

**TYPICAL PERFORMANCE CHARACTERISTICS (continued)**

$T_A = +25^\circ\text{C}$ ,  $V_S = 5\text{V}$ ,  $V_{\text{SENSE}} = V_{\text{IN}+} - V_{\text{IN}-} = 0.5\text{V}/\text{Gain}$ ,  $V_{\text{CM}} = V_{\text{IN}-} = 48\text{V}$ , and  $R_{\text{PULL-UP}} = 5.1\text{k}\Omega$ , unless otherwise noted.

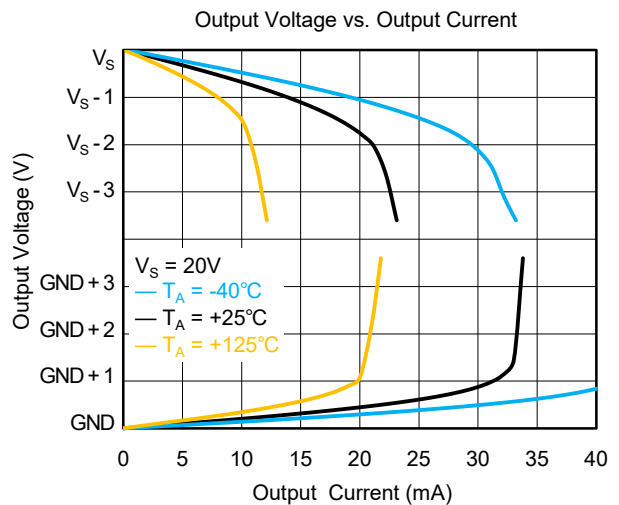
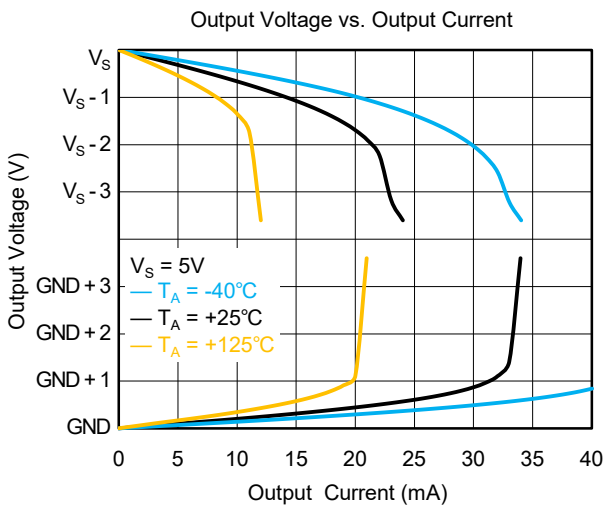
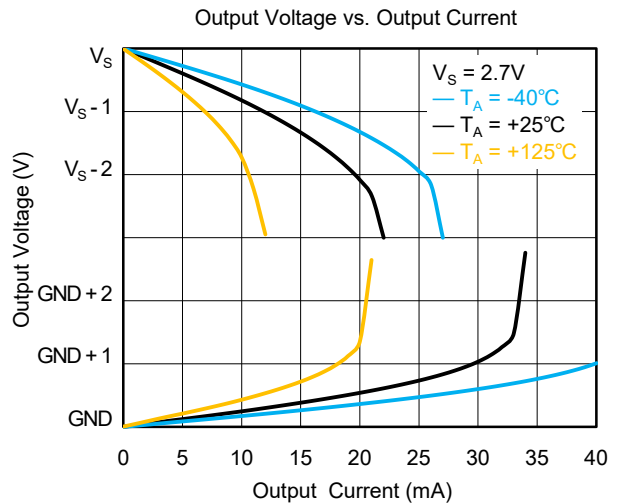
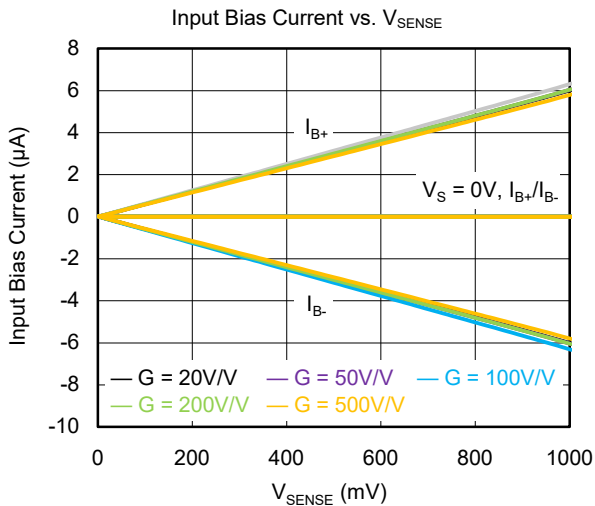
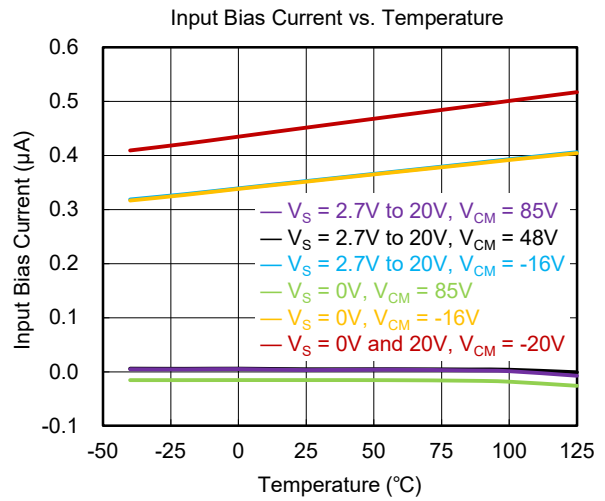
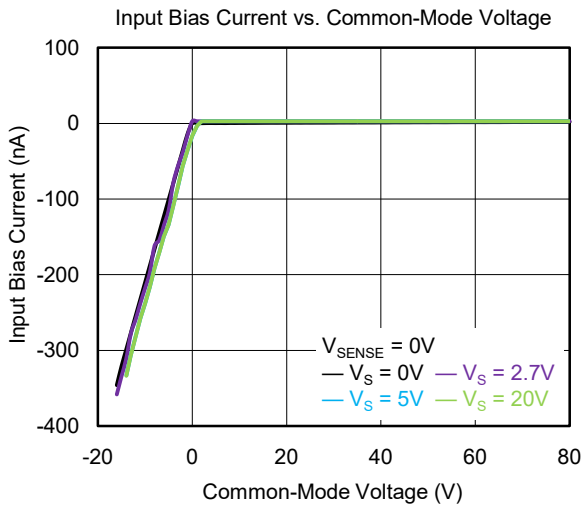

# -16V to 80V, 1.3MHz, High-Precision Current Sense Amplifier with Open-Drain Comparator and Reference

## SGM845xQ

### TYPICAL PERFORMANCE CHARACTERISTICS (continued)

$T_A = +25^\circ\text{C}$ ,  $V_S = 5\text{V}$ ,  $V_{\text{SENSE}} = V_{\text{IN}+} - V_{\text{IN}-} = 0.5\text{V}/\text{Gain}$ ,  $V_{\text{CM}} = V_{\text{IN}-} = 48\text{V}$ , and  $R_{\text{PULL-UP}} = 5.1\text{k}\Omega$ , unless otherwise noted.

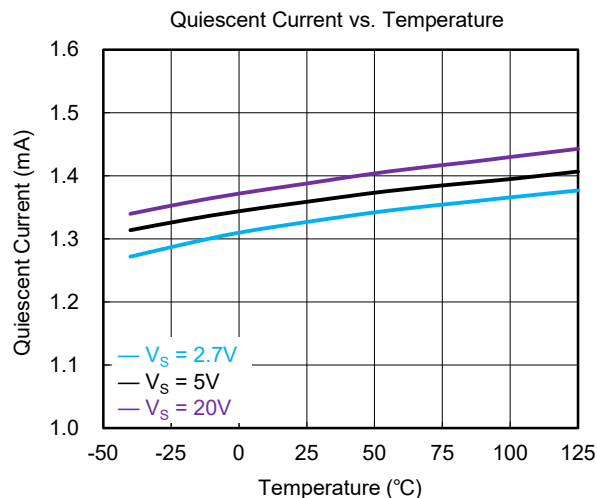
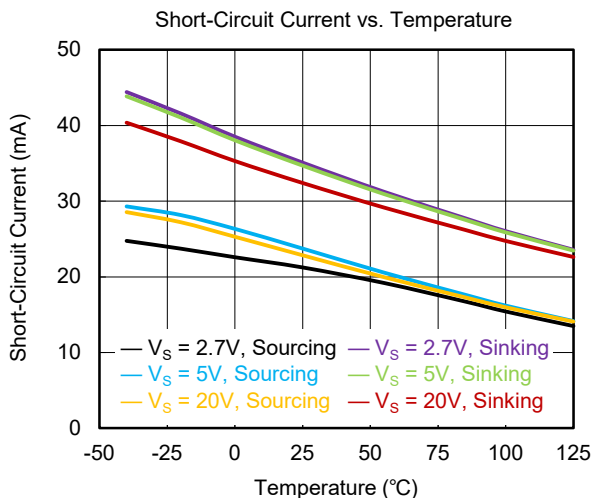
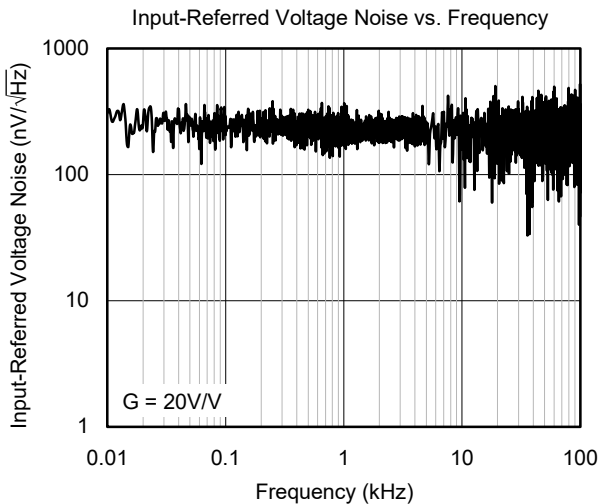
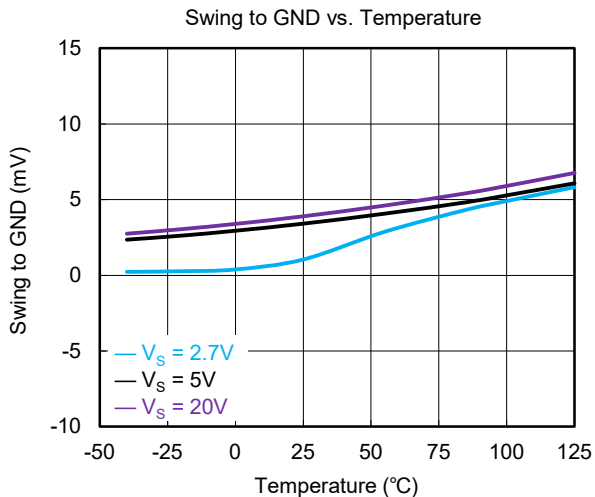
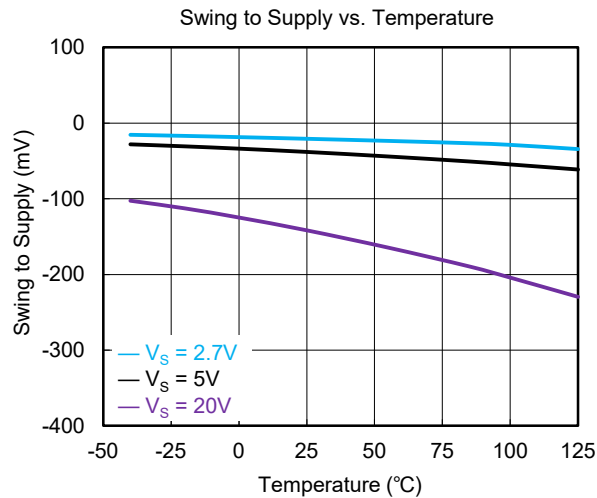
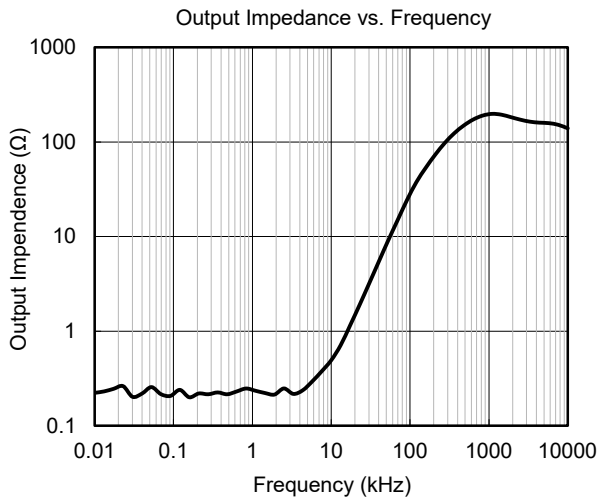

**TYPICAL PERFORMANCE CHARACTERISTICS (continued)**

$T_A = +25^\circ\text{C}$ ,  $V_S = 5\text{V}$ ,  $V_{\text{SENSE}} = V_{\text{IN}+} - V_{\text{IN}-} = 0.5\text{V}/\text{Gain}$ ,  $V_{\text{CM}} = V_{\text{IN}-} = 48\text{V}$ , and  $R_{\text{PULL-UP}} = 5.1\text{k}\Omega$ , unless otherwise noted.

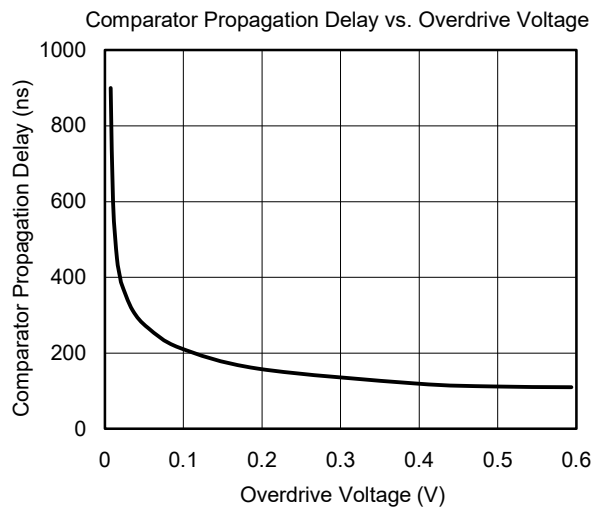
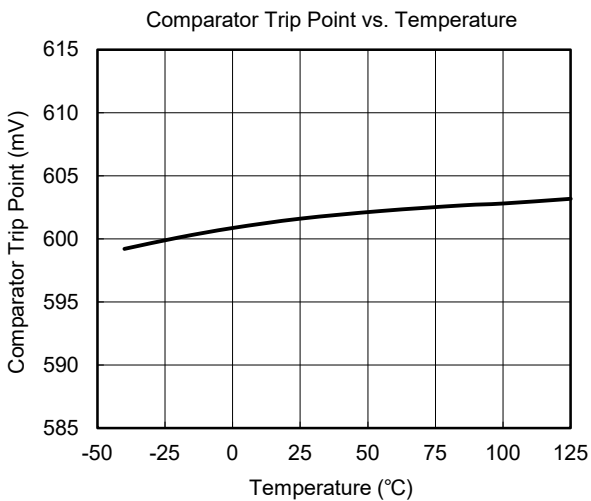
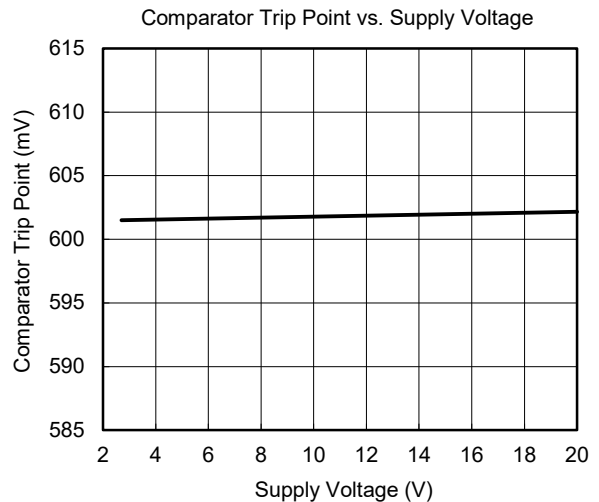
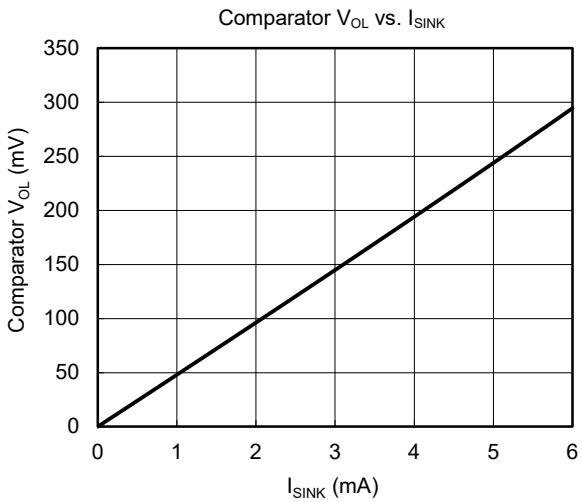
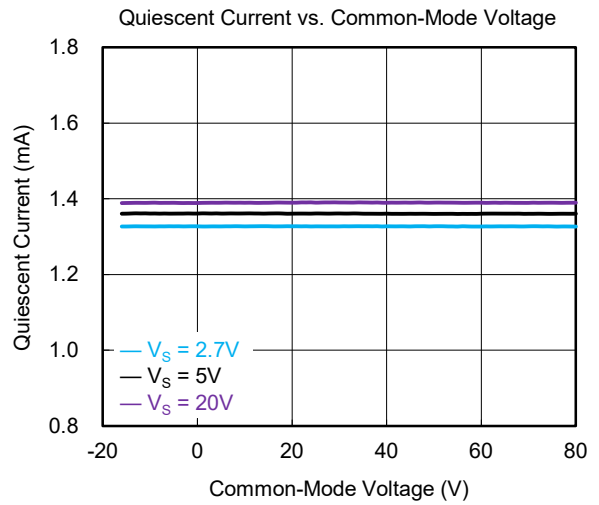
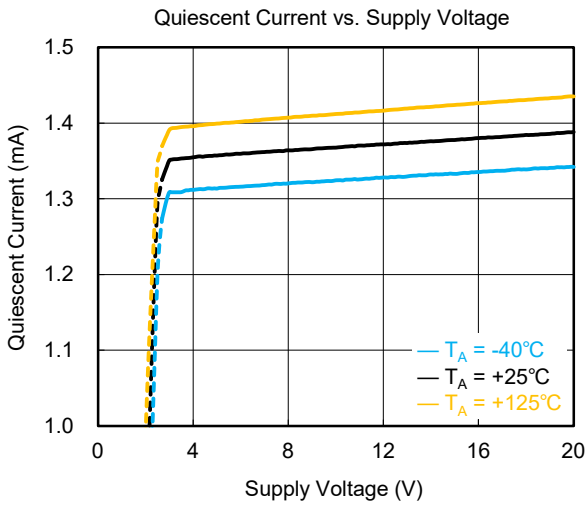

# SGM845xQ

# -16V to 80V, 1.3MHz, High-Precision Current Sense Amplifier with Open-Drain Comparator and Reference

## TYPICAL PERFORMANCE CHARACTERISTICS (continued)

$T_A = +25^\circ\text{C}$ ,  $V_S = 5\text{V}$ ,  $V_{\text{SENSE}} = V_{\text{IN}+} - V_{\text{IN}-} = 0.5\text{V}/\text{Gain}$ ,  $V_{\text{CM}} = V_{\text{IN}-} = 48\text{V}$ , and  $R_{\text{PULL-UP}} = 5.1\text{k}\Omega$ , unless otherwise noted.

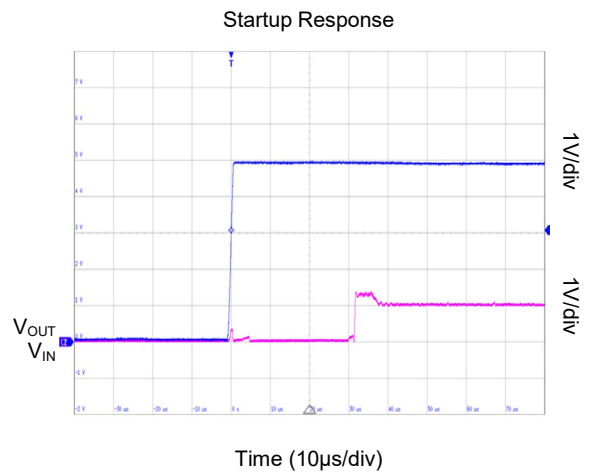
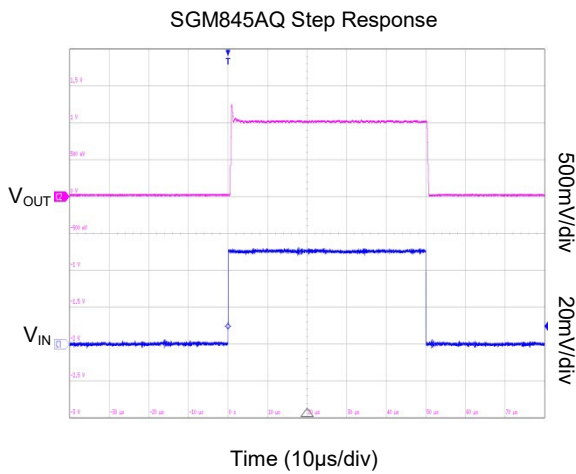
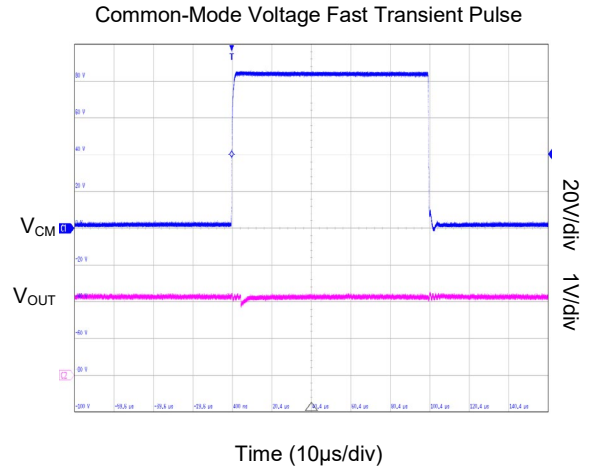
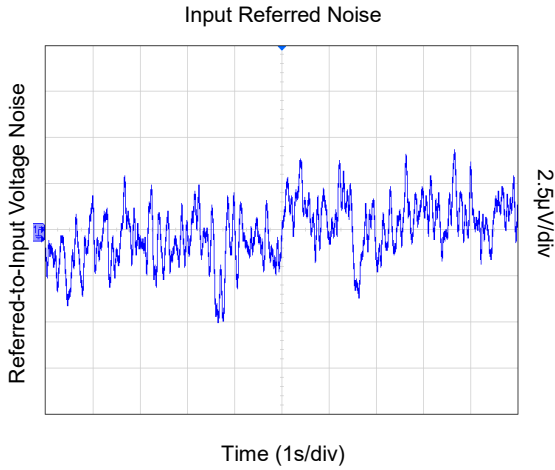
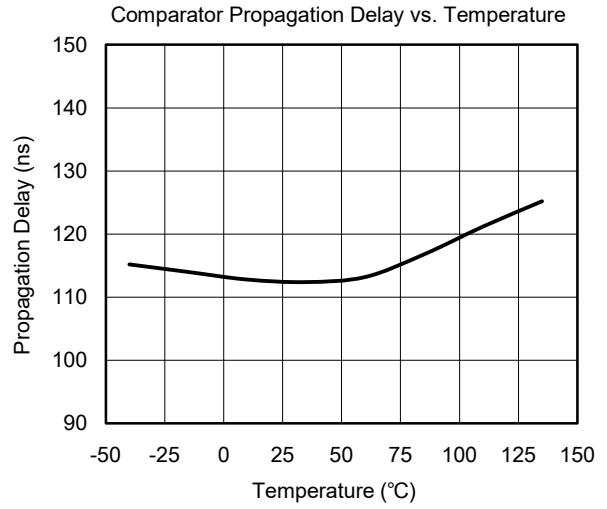
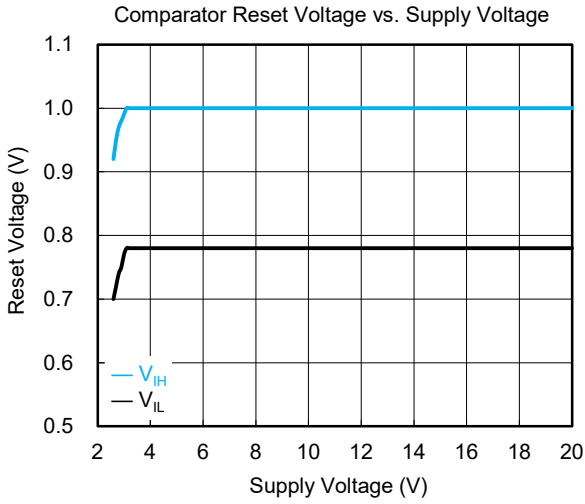

**TYPICAL PERFORMANCE CHARACTERISTICS (continued)**

$T_A = +25^\circ\text{C}$ ,  $V_S = 5\text{V}$ ,  $V_{\text{SENSE}} = V_{\text{IN}+} - V_{\text{IN}-} = 0.5\text{V}/\text{Gain}$ ,  $V_{\text{CM}} = V_{\text{IN}-} = 48\text{V}$ , and  $R_{\text{PULL-UP}} = 5.1\text{k}\Omega$ , unless otherwise noted.

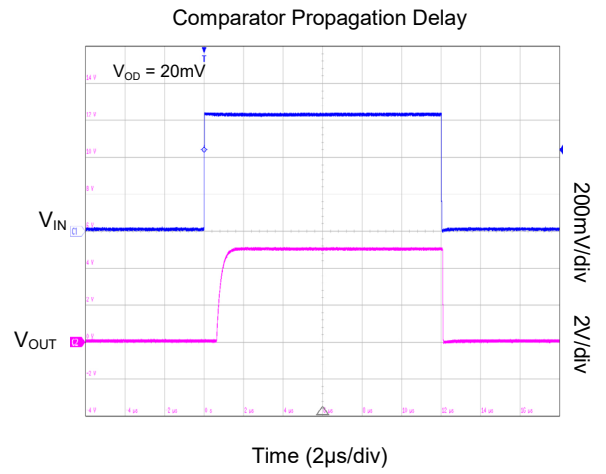
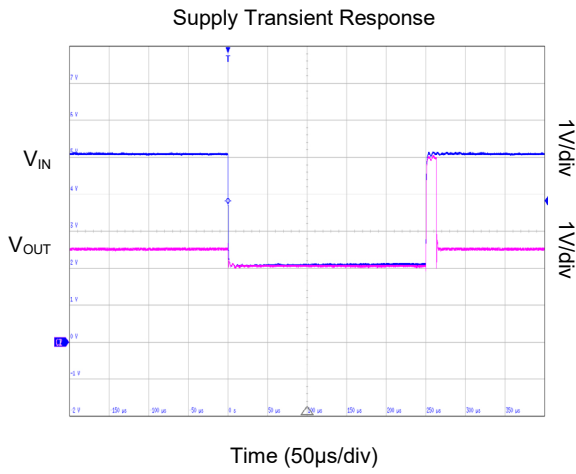

**FUNCTIONAL BLOCK DIAGRAM**

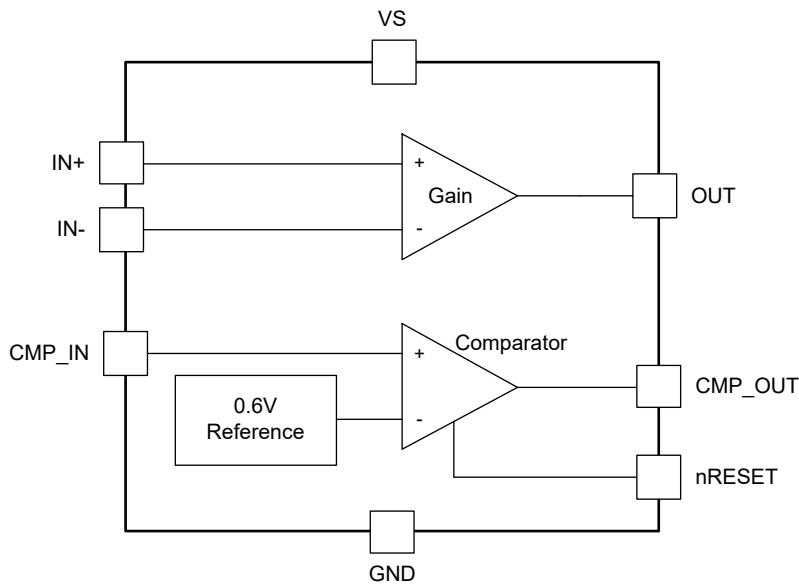

Figure 2. Block Diagram

# SGM845xQ **-16V to 80V, 1.3MHz, High-Precision Current Sense Amplifier with Open-Drain Comparator and Reference**

## DETAILED DESCRIPTION

### Overview

The SGM845xQ is a high-speed, high-precision current-sense amplifier designed for demanding applications operating in noisy, high-voltage environments. It combines a wide common-mode range of -16V to 80V with a precision zero-drift topology, delivering exceptional accuracy. Its architecture is specifically engineered for superior PWM rejection, effectively mitigating output disturbances caused by rapid common-mode transients common in motor control and switched-mode power supplies. With a high signal bandwidth of 1.3MHz and a fast slew rate, the SGM845xQ is ideal for both precise DC current measurement and critical over-current protection events. The device integrates a versatile open-drain comparator with a 0.6V reference, providing a complete solution for current monitoring and fault detection.

### Feature Description

#### High PWM Rejection for Noisy Environments

A key feature of the SGM845xQ is its excellent rejection of large, high-frequency common-mode voltage swings (dV/dt), often referred to as PWM rejection. In applications such as H-bridge motor drivers or solenoid controls, the common-mode voltage across the shunt resistor can transition rapidly. The SGM845xQ's high bandwidth (1.3MHz) and high slew rate (8V/μs) allow its internal circuitry to settle quickly, preventing these common-mode transients from being rectified and appearing as unwanted disturbances or errors on the output signal. This results in a cleaner, more accurate representation of the actual load current, simplifying system design and improving control loop stability.

#### High Signal Bandwidth for Fast Response

The SGM845xQ offers a high signal bandwidth of 1.3MHz, which is crucial for applications requiring rapid detection of current events. This high bandwidth, combined with the integrated fast comparator, enables a very short propagation delay from the input sense resistor to the comparator's output. This makes the SGM845xQ an excellent choice for implementing fast-acting over-current protection (OCP) circuits, helping to protect power stages and loads from damaging fault conditions. The unique multi-stage design ensures that high bandwidth is maintained across different gain options, providing consistent performance for a wide range of currents.

#### Wide Common-Mode Range Operation

The SGM845xQ employs an advanced input stage topology that decouples the input common-mode voltage range from the device's power supply voltage ( $V_S$ ). This allows the SGM845xQ to accurately sense currents on rails from -16V to 80V, regardless of whether it is powered by a 3.3V, 5V, or up to a 20V supply. This feature provides immense flexibility, enabling the device to be used in high-side, low-side, or even in-line current sensing configurations that extend well beyond its own supply rails.

#### Precision Zero-Drift Front-End

At the core of the SGM845xQ is a zero-drift input architecture, which delivers exceptional precision with a typical offset voltage of just  $\pm 100\mu\text{V}$  and near-zero offset drift over temperature. This high level of accuracy enables the use of smaller shunt resistors to minimize power loss without sacrificing measurement resolution, a critical advantage in power-sensitive applications. The internal gain is set by a highly matched, low-drift resistor network, ensuring a stable and predictable gain error across the entire operating temperature range from  $-40^\circ\text{C}$  to  $+125^\circ\text{C}$ .

#### Low Input Bias Current

A significant advantage of the SGM845xQ's architecture is its low and remarkably stable input bias current across the entire -16V to 80V common-mode range. Unlike traditional topologies where bias current can increase significantly with common-mode voltage, the SGM845xQ maintains a consistent input characteristic. This behavior minimizes measurement errors that would otherwise be introduced by varying source impedances, ensuring high accuracy even in systems with fluctuating bus voltages. This predictable performance simplifies error budgeting and enhances overall system reliability.

#### Low $V_{\text{SENSE}}$ Operation

The SGM845xQ excels at accurately measuring very small differential voltages ( $V_{\text{SENSE}}$ ), thanks to its precision zero-drift front-end. The architecture inherently provides ultra-low offset voltage and near-zero drift, enabling the device to resolve microvolt-level signals across its full operating temperature range. This capability is particularly valuable in high-current applications, as it allows designers to specify shunt resistors with very low ohmic values.

# SGM845xQ -16V to 80V, 1.3MHz, High-Precision Current Sense Amplifier with Open-Drain Comparator and Reference

## DETAILED DESCRIPTION (continued)

Using smaller shunts directly translates to significant reductions in power dissipation ( $I^2R$  loss) and thermal stress, leading to a more efficient and reliable system design. The minimum measurable  $V_{SENSE}$  is primarily determined by the device's output swing-to-ground capability ( $V_{SN}$ ) and the selected gain.

### Wide Fixed Gain Output

To accommodate a wide variety of current sensing applications, the SGM845xQ is offered in five fixed-gain options: 20V/V, 50V/V, 100V/V, 200V/V, and 500V/V. Each version is factory-calibrated to achieve an exceptionally low typical gain error of just  $\pm 0.03\%$ . Furthermore, the gain is remarkably stable over temperature, with a typical drift of only 10ppm/ $^{\circ}C$ . This high level of precision and thermal stability ensures reliable and repeatable current measurements across the full operating range of  $-40^{\circ}C$  to  $+125^{\circ}C$ , making the SGM845xQ an ideal choice for high-performance systems. Designers can select the optimal gain to maximize the signal-to-noise ratio and best utilize the input range of their ADC.

The gain of the SGM845xQ is set by a precision, low-drift internal resistor network. While the ratio of these internal resistors is excellently matched and stable over temperature to guarantee gain accuracy, their absolute values can have a wider manufacturing tolerance. Therefore, SGMICRO strongly advises against adding external resistors in an attempt to modify the gain, as this would introduce significant and unpredictable errors. The device should be used with its intended fixed gain.

### Wide Supply Range

The SGM845xQ operates over a wide supply voltage range from 2.7V to 20V, making it compatible with a variety of standard logic and analog rails. A key architectural benefit is that the device's input common-mode voltage capability is completely independent of its supply voltage. However, the output voltage swing is inherently limited by the supply rails. The output can swing to within a few millivolts of ground (see  $V_{SN}$  in the Electrical Characteristics table) and typically up to 200mV below the positive supply rail ( $V_S$ ), providing a wide dynamic range for the amplified current sense signal.

### Integrated Comparator

The SGM845xQ incorporates a flexible open-drain comparator, which features a precise, internal 0.6V

voltage reference for threshold detection. The comparator's input,  $CMP\_IN$ , is designed to accommodate signals from 0V up to 5.5V or  $V_S$ , whichever is lower. To ensure stable and reliable switching in noisy industrial environments, a built-in 8mV (TYP) hysteresis is included. This feature prevents output chattering when the input signal is around the trip point, as illustrated in Figure 3. The comparator's open-drain output offers significant system design flexibility, as it can be pulled up to any voltage rail from 0V to 20V via an external resistor, independent of the SGM845xQ's own supply voltage.

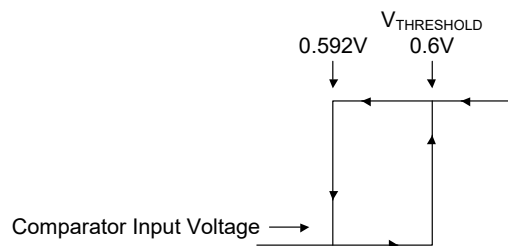

Figure 3. The Comparator Threshold and Hysteresis

### nRESET Function

The nRESET pin provides powerful control over the comparator's operational mode, allowing designers to select between transparent and latching behavior to best suit their application's logic, as shown in Figure 4. Specifically, when the nRESET pin is held low or left floating, the comparator functions in a transparent mode, with its output dynamically following the input signal relative to the 0.6V threshold. For applications requiring event capture, pulling the nRESET pin high activates the latching mode. Once triggered by an input exceeding the threshold, the comparator's output latches high and remains in that state irrespective of subsequent input changes. This mode is particularly useful for capturing transient fault events without requiring continuous monitoring by a microcontroller. Releasing the latch is simple: the nRESET pin must be returned to a low or floating state to restore transparent operation.

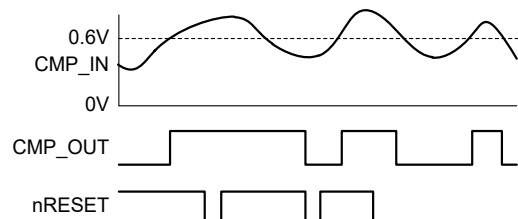

Figure 4. The Comparator nRESET Function

**DETAILED DESCRIPTION (continued)**

**Short Propagation Delay**

The SGM845xQ is engineered for speed. The synergistic combination of its high-speed current sense amplifier and the fast internal comparator results in a remarkably short total propagation delay of just 1μs. This delay is measured from the moment the differential sense voltage across the shunt resistor exceeds the configured over-current threshold, to the point where the comparator's output flags the event. The signal path — from sense resistor, through the amplifier, the external V<sub>OUT</sub> divider network, and finally the comparator — is optimized for minimal latency. This rapid, end-to-end response makes the SGM845xQ exceptionally well-suited for implementing robust and fast-acting OCP in systems where component protection is paramount.

**Comparator Input Bias Current**

The comparator input of the SGM845xQ employs a high-impedance design, ensuring that the comparator's input bias current (I<sub>BCMP\_IN</sub>) remains at the nA level across the entire input voltage (V<sub>CMP\_IN</sub>) range. As depicted in Figure 5, this results in a linear relationship between the bias current and the input voltage. Critically, for input voltages near the 0.6V comparator threshold, the bias current remains about 18nA at room temperature. This characteristic ensures that the bias current does not significantly compromise the accuracy of the alert threshold (V<sub>TH</sub>). To further optimize V<sub>TH</sub> precision, it is advisable to avoid high-value resistors for the external voltage divider. As a guideline, the total resistance of this network (shown in the Figure 6) should be kept under 100kΩ.

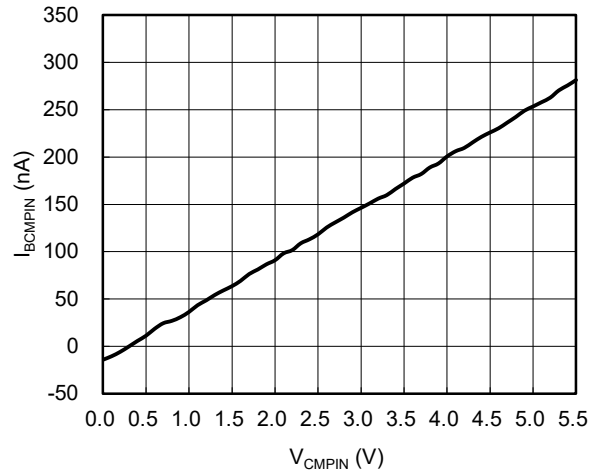

**Figure 5. Comparator I<sub>BCMP\_IN</sub> vs. V<sub>CMP\_IN</sub>**

**Device Functional Modes**

**Basic Connections**

A fundamental circuit configuration for the SGM845xQ is illustrated in Figure 6. The device is versatile enough to be configured for unidirectional current sensing in either high-side or low-side arrangements. For optimal accuracy, the input pins (IN+ and IN-) should be connected to the shunt resistor using Kelvin (4-wire) connections. This technique minimizes the impact of any parasitic resistance in series with the shunt element.

Stable operation requires a power-supply bypass capacitor. In systems with noisy or high-impedance power sources, additional decoupling may be necessary to filter out supply-line noise. Bypass capacitors should be placed in close proximity to the device's VS and GND pins. A value of 0.01μF is typically recommended.

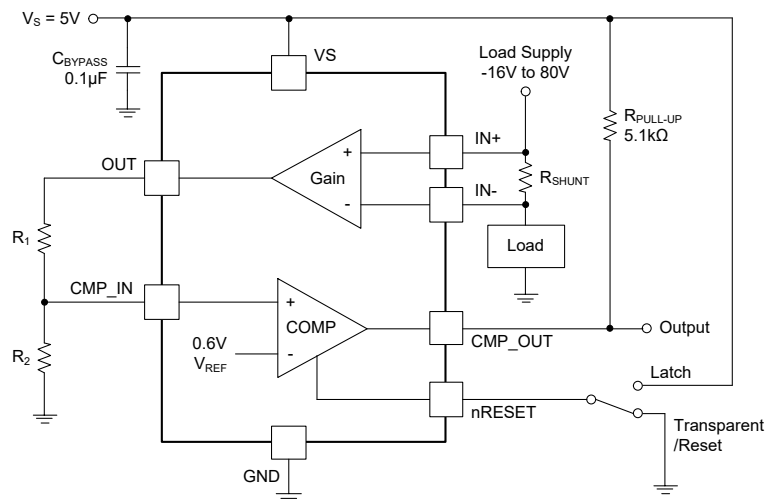

**Figure 6. Basic Connections**

**DETAILED DESCRIPTION (continued)**

**Over-Current Threshold Connection**

As shown in Figure 6, the SGM845xQ’s internal comparator can be configured to generate an over-current alert. The trip point is determined by comparing a divided-down version of the amplifier’s output voltage ( $V_{OUT}$ ) against the internal 0.6V reference. The external resistors,  $R_1$  and  $R_2$ , form this voltage divider. Equation 1 defines the mathematical relationship between the over-current threshold and the values of the gain,  $R_{SHUNT}$ ,  $R_1$  and  $R_2$ .

$$I_{SENSE\_ALERT\_THRESHOLD} = \frac{0.6 \times (R_1 + R_2)}{R_2 \times G \times R_{SHUNT}} \quad (1)$$

Since  $R_1$  and  $R_2$  present a load to the OUT pin, SGMICRO suggests their sum be greater than 10kΩ to preserve the output swing range and reduce overall supply current. However, as noted in the Comparator Input Bias Current section, excessively high resistor values can affect the threshold accuracy ( $V_{TH}$ ). The Application Information section provides examples for selecting appropriate resistor values.

**High-side Switch Over-Current Shutdown**

The SGM845xQ measures the differential voltage produced by current flowing through a shunt resistor.

Figure 7 presents an application circuit where the SGM845xQ is used to control a high-side switch during an over-current event. When the monitored current surpasses the user-defined threshold, the comparator’s output (CMP\_OUT) goes high. This signal, in turn, drives an external transistor ( $Q_1$ ) to turn off the main high-side switch. The transistor  $Q_1$  serves to isolate the low-voltage CMP\_OUT pin from the high-voltage supply rail.

For unidirectional current measurement, the shunt resistor can be placed in several locations. Options 1 and 2 represent high-side sensing, while option 3 is low-side sensing. Although both are high-side methods, option 1 measures the total current including that drawn by  $Q_1$ , whereas option 2 does not. High-side sensing offers the advantages of being immune to ground disturbances and capable of detecting load shorts. It requires a current sense amplifier with high CMRR and a wide common-mode range, as the inputs are near the supply potential. Low-side sensing does not necessitate a high-voltage amplifier but can introduce ground noise and is unable to detect direct shorts to ground at the load.

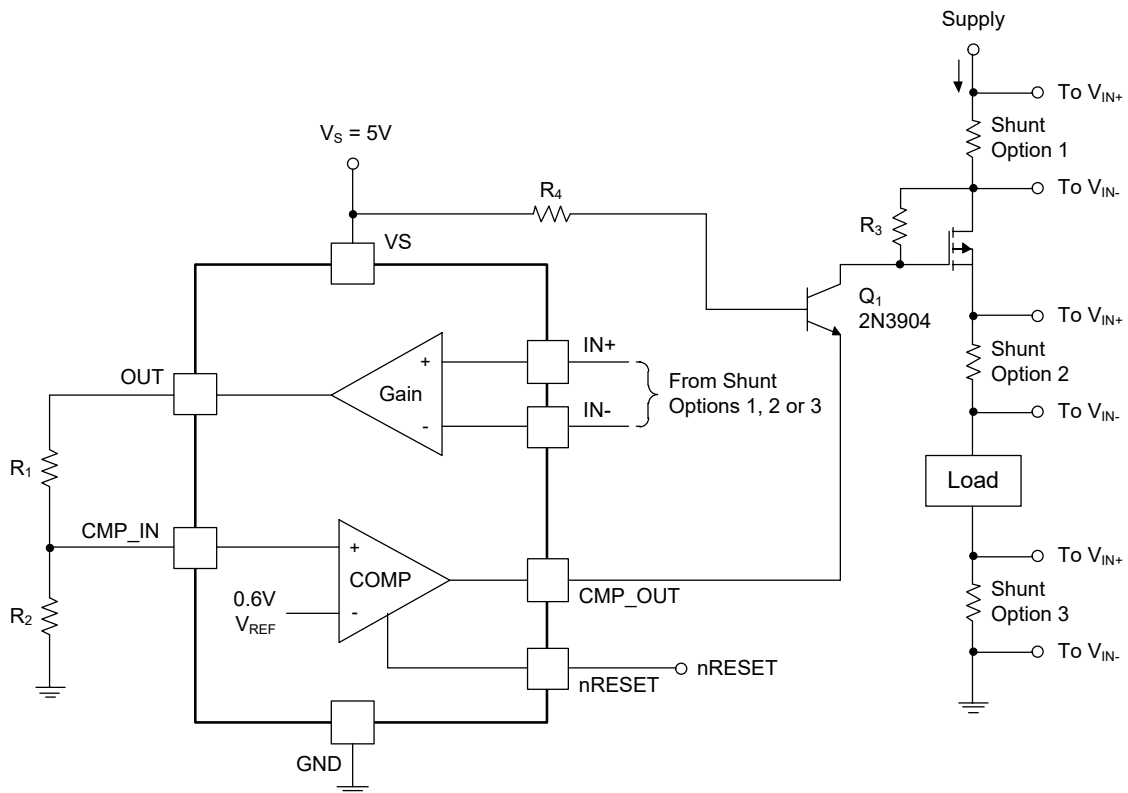

**Figure 7. High-side Switch for Over-Current Shutdown**

# SGM845xQ -16V to 80V, 1.3MHz, High-Precision Current Sense Amplifier with Open-Drain Comparator and Reference

## DETAILED DESCRIPTION (continued)

### Bidirectional Over-current Comparator

While the SGM845xQ is designed for unidirectional operation, two devices can be configured to monitor bidirectional currents, as shown in Figure 8. In this arrangement, each SGM845xQ is responsible for one

direction of current flow, as the polarity of the differential voltage across the shunt resistor will be opposite for each. Together, they provide a comprehensive bidirectional over-current monitoring solution.

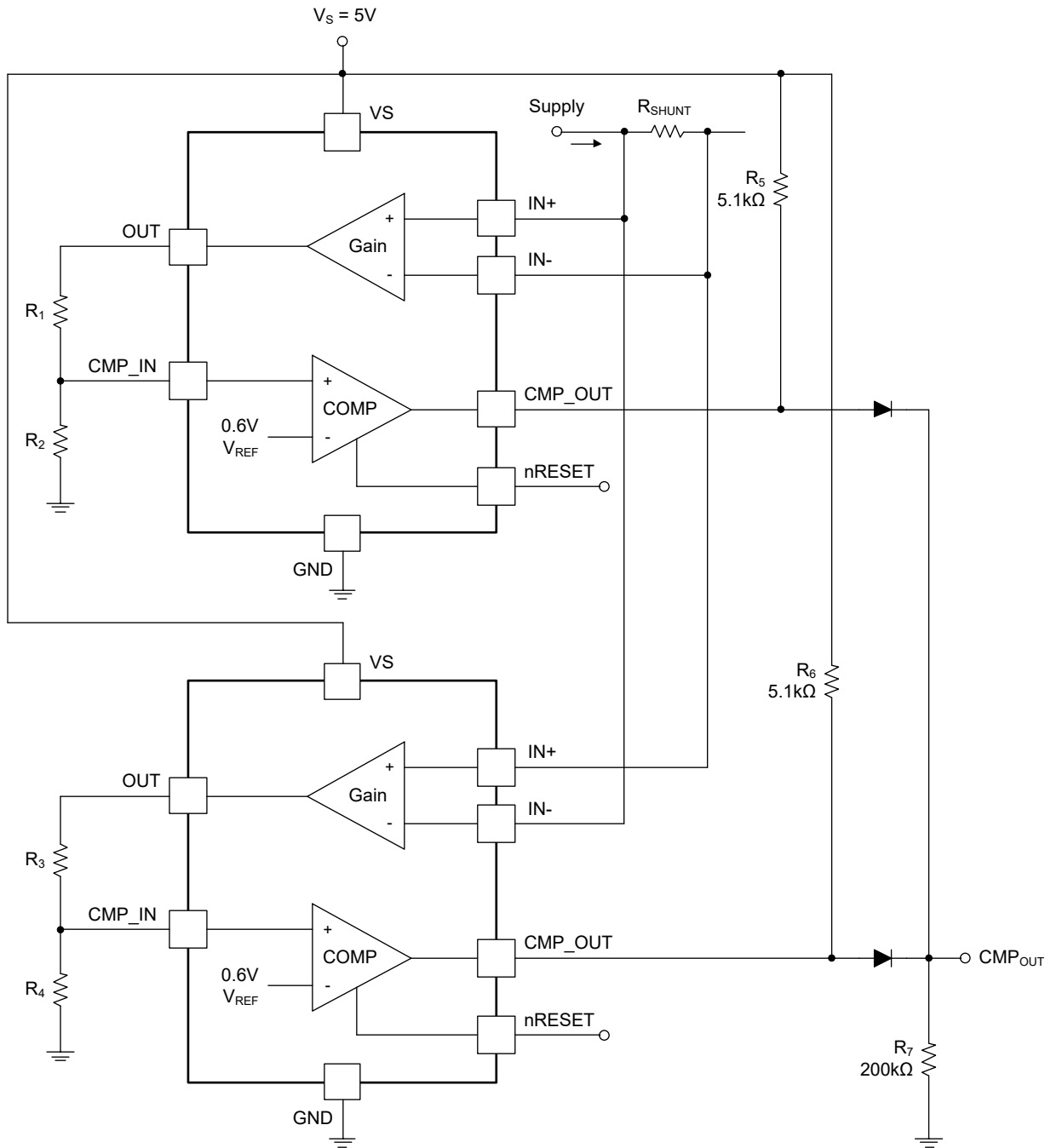

**Figure 8. Ground Referenced Output**

# -16V to 80V, 1.3MHz, High-Precision Current Sense Amplifier with Open-Drain Comparator and Reference

## SGM845xQ

### APPLICATION INFORMATION

The primary function of the SGM845xQ is to amplify the small differential voltage generated across a current-shunt resistor ( $R_{SENSE}$ ) as current is delivered to a load. Due to its wide input common-mode voltage range and high common-mode rejection ratio (CMRR), the SGM845xQ can be deployed across a diverse array of voltage rails while consistently delivering accurate current measurements.

#### R<sub>SENSE</sub> and Device Gain Selection

Selecting the appropriate sense resistor ( $R_{SENSE}$ ) and amplifier gain is critical for optimizing the performance of any current sensing system. For maximum accuracy, it is generally advisable to choose the largest possible  $R_{SENSE}$  value. A larger resistance produces a stronger differential input signal for a given current, which effectively minimizes the relative error contribution from the amplifier's input offset voltage.

However, the selection of  $R_{SENSE}$  is constrained by practical considerations, including the resistor's physical size, its packaging, and most importantly, its power dissipation limit. The maximum allowable value for the sense resistor, based on a power dissipation budget, can be calculated using Equation 2.

$$R_{SENSE} < \frac{PD_{MAX}}{I_{MAX}^2} \quad (2)$$

where:

$PD_{MAX}$  represents the maximum permissible power dissipation in the  $R_{SENSE}$  component.

$I_{MAX}$  is the peak current expected to flow through  $R_{SENSE}$ .

Maximize the accuracy of a current sense amplifier, SGMICRO recommends to choose the largest current sense resistor value possible in an application. A larger value sense resistor maximizes the differential input signal for a given amount of current flow and reduces the error contribution of the offset voltage. However, there are practical limits as to how large the current-sense resistor value can be in a given application because of the physical dimensions of the resistor, package construction and maximum power

dissipation. Equation 2 gives the maximum value for the current-sense resistor for a given power dissipation budget. Further constraints on the choice of  $R_{SENSE}$  and gain (G) are imposed by the amplifier's power supply voltage ( $V_S$ ) and its output swing-to-rail limitations. The amplified signal must fit within the output dynamic range. Equation 3 establishes the condition to prevent the output from clipping at the positive supply rail:

$$I_{MAX} \times R_{SENSE} \times G < V_{SP} \quad (3)$$

where:

$I_{MAX}$  is the maximum current through  $R_{SENSE}$ .

G is the selected gain of the amplifier.

$V_{SP}$  is the positive output swing limit, as specified in the Electrical Characteristics table.

When designing, a trade-off between the  $R_{SENSE}$  value and the amplifier gain must be managed to avoid positive output saturation. If an  $R_{SENSE}$  value chosen for optimal power dissipation results in a calculated output voltage that exceeds  $V_{SP}$ , a lower-gain version of the SGM845xQ should be selected.

Similarly, the negative output swing limitation dictates the minimum practical value for the sense resistor in a given application. To ensure the output signal is not clipped near ground, the condition in Equation 4 must be met:

$$I_{MIN} \times R_{SENSE} \times G > V_{SN} \quad (4)$$

where:

$I_{MIN}$  is the minimum current that will flow through  $R_{SENSE}$ .

G is the gain of the current-sense amplifier.

$V_{SN}$  is the negative output swing of the device.

Table 1 provides a practical example, illustrating the outcomes of using the five different gain variants of the SGM845xQ. The data highlights that higher-gain options enable the use of smaller shunt resistors, which in turn reduces the overall power dissipated in the sensing element. Note that the design example presented assumes a full-scale current of 10A, with the system configured for a maximum output voltage of 5V.

**Table 1. R<sub>SENSE</sub> Selection and Power Dissipation**

Parameter		Equation	Results at V <sub>S</sub> = 5 V				
			SGM845AQ	SGM845BQ	SGM845CQ	SGM845DQ	SGM845EQ
G	Gain		20V/V	50V/V	100V/V	200V/V	500V/V
V <sub>DIFF</sub>	Ideal differential input voltage	V <sub>DIFF</sub> = V <sub>OUT</sub> /G	250mV	100mV	50mV	25mV	10mV
R <sub>SENSE</sub>	Current sense resistor value	R <sub>SENSE</sub> = V <sub>DIFF</sub> /I <sub>MAX</sub>	25mΩ	10mΩ	5mΩ	2.5mΩ	1mΩ
P <sub>SENSE</sub>	Current-sense resistor power dissipation	R <sub>SENSE</sub> × I <sub>MAX</sub> <sup>2</sup>	2.5W	1W	0.5W	0.25W	0.1W

**APPLICATION INFORMATION (continued)**

**Typical Application**

The SGM845xQ is engineered as a unidirectional current sense amplifier. Its primary function is to accurately measure current flowing through a shunt resistor across a wide common-mode voltage range, from -16V up to 80V, making it suitable for a diverse set of applications.

**Current Sensing in a Solenoid Application**

**Design Requirements**

For this specific application example, the system operates with a common-mode voltage that varies between 0V and 24V. The SGM845xQ is powered by a 5V supply. The design objective is to monitor a maximum sense current of 1.5A, while triggering an alert if the current surpasses a threshold of 1.9A.

Adhering to the principles outlined in the  $R_{SENSE}$  and Device Gain Selection section, a shunt resistor ( $R_{SENSE}$ )

of 50mΩ and an amplifier gain of 50V/V are chosen. This combination provides an optimal output dynamic range for the specified current levels. The complete design parameters for this application are summarized in Table 2.

**Table 2. Design Parameters**

Design Parameters	Example Value
Power Supply Voltage	5V
Common-Mode Voltage Range	0V to 24V
Maximum Sense Current	1.5A
$R_{SENSE}$ Resistor	50mΩ
Gain Option	50V/V
Over-Current Threshold	1.9A
$R_1$	69.15kΩ
$R_2$	10kΩ

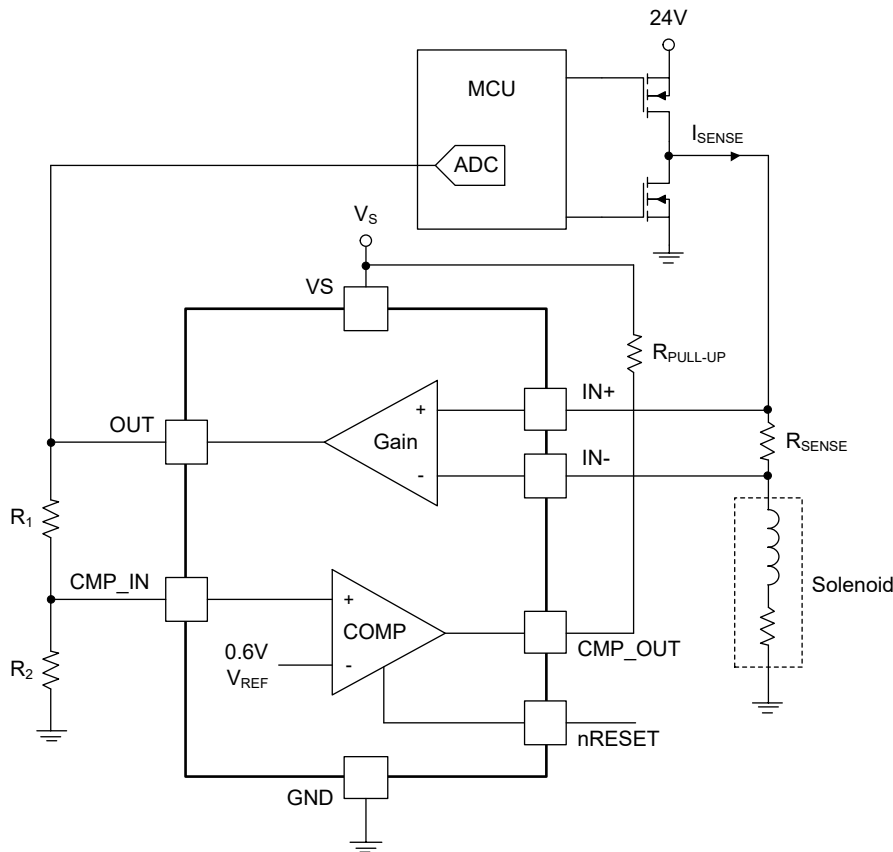

**Figure 9. Current Sensing in a Solenoid Application**

**APPLICATION INFORMATION (continued)**

**Detailed Design Procedure**

In a typical solenoid drive application, the SGM845xQ is employed to monitor the load current. This is achieved by measuring the voltage drop across a 50mΩ shunt resistor, which is strategically placed at the half-bridge output. The SGM845xQ senses the differential voltage across this shunt and applies an internal gain of 50V/V. The resulting amplified analog signal at the OUT pin is then fed into an analog-to-digital converter (ADC), typically within a microcontroller (MCU), for digital processing and monitoring. For the over-current detection circuit, the resistor R<sub>2</sub> is set to a fixed value of 10kΩ. This value is chosen to minimize the loading effect on the amplifier’s output (OUT), as recommended in the Basic Connections section. Subsequently, using Equation 1, the value for R<sub>1</sub> is calculated to be 69.15kΩ.

$$1.9A = \frac{0.6V \times (R_1 + 10k\Omega)}{10k\Omega \times 50 \times 50m\Omega}$$

Together, the R<sub>1</sub> (69.15kΩ) and R<sub>2</sub> (10kΩ) resistors form a voltage divider that scales the output signal before it is fed to the internal comparator. This divider network effectively establishes the over-current alert threshold at 1.9A.

Solenoid loads, being highly inductive in nature, are susceptible to various failure modes. They are commonly found in systems requiring precise control, such as positioners, fluid regulators, and valves. Continuous, real-time current monitoring can provide early indications of a deteriorating solenoid, preventing failures that could compromise the entire control loop. Furthermore, high-side current sensing with the SGM845xQ can detect potentially damaging ground faults in the solenoid or the driving FETs. The SGM845xQ’s high bandwidth and fast slew rate are key attributes that enable the rapid detection of such over-current events, thereby protecting the solenoid from short-to-ground fault damage.

It is important to note that the SGM845xQ is a unidirectional amplifier, designed for operation with a positive differential input voltage (V<sub>SENSE</sub>). Applying a negative V<sub>SENSE</sub> will drive the device into an overload or saturated state. The amplifier will require a specific recovery time to return to linear operation once V<sub>SENSE</sub> becomes positive again. The duration of this overload recovery time is proportional to the magnitude and duration of the negative V<sub>SENSE</sub> applied.

**Low-Side Switch Over-Current Shutdown**

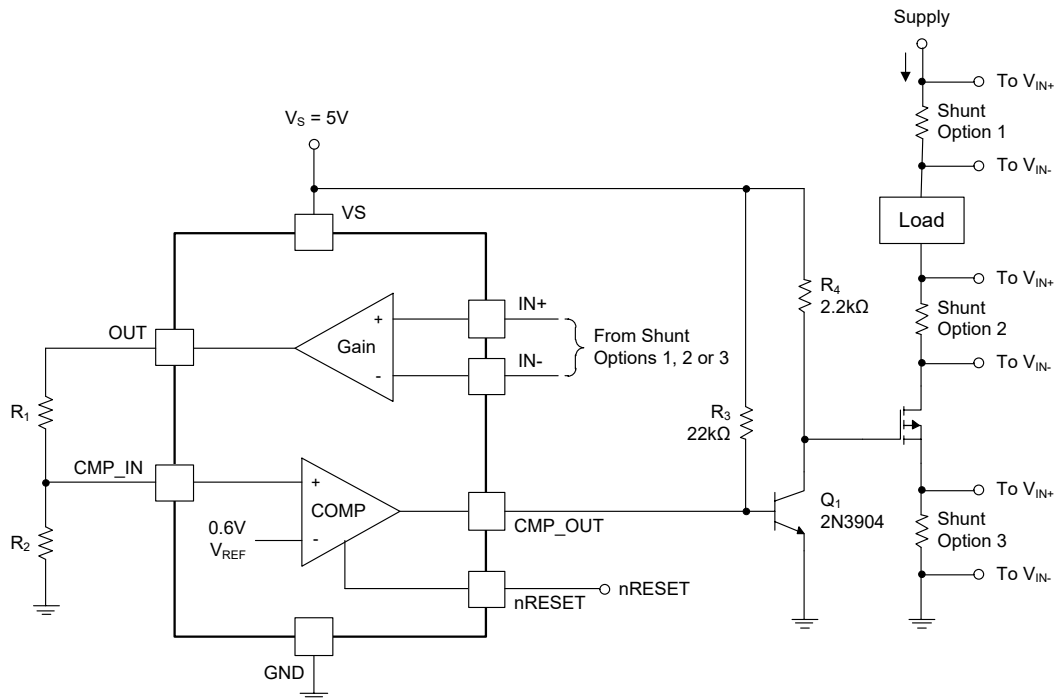

**Figure 10. Low-side Switch Over-Current Shutdown**

**APPLICATION INFORMATION (continued)**

**Design Requirements**

This application demonstrates how the SGM845xQ can be used for over-current protection. The device monitors a unidirectional current flowing through a shunt resistor. An over-current event is detected when the resulting differential input voltage surpasses a predefined threshold. Upon reaching the trip point set by the  $R_1/R_2$  divider, the comparator's output (CMP\_OUT) transitions to a high state. This signal then activates an external transistor ( $Q_1$ ), which in turn pulls the gate of the main pass-FET low, effectively interrupting the current flow.

For this particular design example, the common-mode voltage is fixed at 5V, and the SGM845xQ is also powered by a 5V supply. The system is designed to handle a maximum sense current of 1A and must trigger a shutdown if the current exceeds 1.2A.

Following the selection methodology outlined in the  $R_{SENSE}$  and Device Gain Selection section, a shunt resistor ( $R_{SHUNT}$ ) of 100m $\Omega$  is paired with the 20V/V gain version of the SGM845xQ. This combination ensures an adequate output dynamic range for the application. All relevant design parameters are consolidated in Table 3.

**Table 3. Design Parameters**

Design Parameters	Example Value
Power Supply Voltage	5V
Common-Mode Voltage Range	5V
Maximum Sense Current	1A
$R_{SENSE}$ Resistor	100m $\Omega$
Gain Option	20V/V
Over-Current Threshold	1.2A
$R_1$	10.2k $\Omega$
$R_2$	3.4k $\Omega$

**Detailed Design Procedure**

Figure 10 illustrates the fundamental connections for this SGM845xQ application. It is crucial that the input terminals (IN+ and IN-) are connected to the current sense resistor with minimal trace length to avoid introducing parasitic series resistance. In this circuit, the SGM845xQ monitors the current across a 100m $\Omega$  shunt placed in series with the load. The device measures the differential voltage developed across this shunt and applies a fixed internal gain of 20V/V to the signal.

To establish the over-current threshold,  $R_1$  is set to a fixed value of 10.2k $\Omega$ , a choice made to prevent significant loading of the OUT pin as suggested in the Basic Connections guidelines. Using Equation 1, the corresponding value for  $R_2$  is then calculated to be 3.4k $\Omega$ . This resistive divider, formed by  $R_1$  (10.2k $\Omega$ ) and  $R_2$  (3.4k $\Omega$ ), scales the amplifier's output voltage down to create the input for the comparator, thereby setting the over-current alert threshold to 1.2A.

**Power Supply Recommendations**

The SGM845xQ is capable of making accurate measurements on voltage rails that extend far beyond  $V_S$ . This is possible because its inputs (IN+ and IN-) can operate over a wide common-mode range, from -16V to 80V, independent of the  $V_S$  potential. As a practical example, even when the SGM845xQ is powered by a 5V supply, it can accurately monitor current on a shunt with a common-mode voltage as high as 80V.

**Power Supply Decoupling**

For stable operation, a bypass capacitor should be placed as close as possible to VS and GND pins. SGMICRO recommends a bypass capacitor of at least 0.1 $\mu$ F. For systems with particularly noisy or high-impedance power supplies, additional or larger decoupling capacitors may be beneficial.

**LAYOUT**

**Layout Guidelines**

Attention to good layout practices is always recommended.

The input pins should be connected to the sense resistor pads using a Kelvin (4-wire) connection. This technique ensures that the measurement is sensitive only to the voltage drop across the current-sensing element itself, excluding any voltage drops across the high-current traces. Improper routing can easily introduce parasitic trace resistance between the input pins, which, given the low resistance of the shunt, can lead to significant measurement inaccuracies.

As mentioned previously, the power-supply bypass capacitor (typically 0.1µF) must be positioned in immediate proximity to the VS and GND pins of the device. This placement minimizes the inductance of the

connection loop, ensuring effective filtering of high-frequency noise from the power supply.

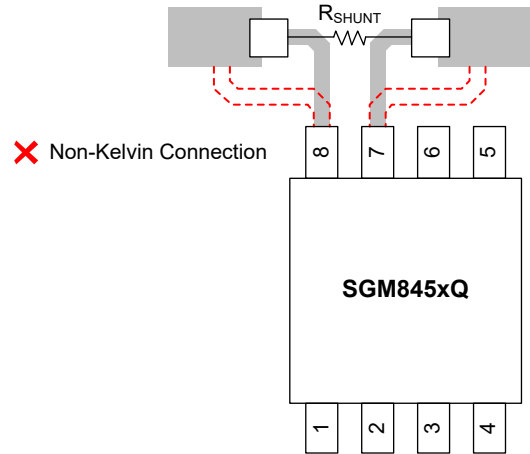

**Figure 11. Shunt Connections to the SGM845xQ**

**REVISION HISTORY**

NOTE: Page numbers for previous revisions may differ from page numbers in the current version.

Changes from Original to REV.A (JUNE 2026)	Page
Changed from product preview to production data.....	All

PACKAGE OUTLINE DIMENSIONS

MSOP-8

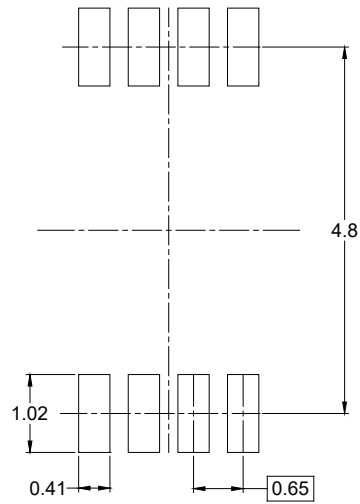
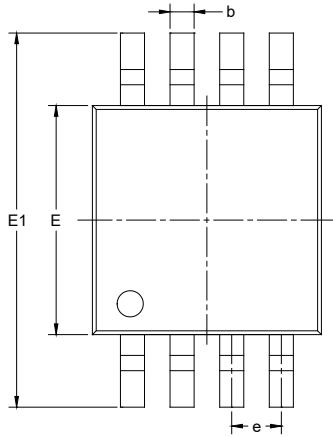

RECOMMENDED LAND PATTERN (Unit: mm)

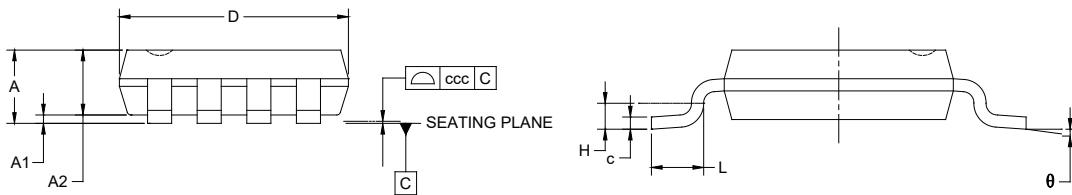

Symbol	Dimensions In Millimeters		
	MIN	NOM	MAX
A	-	-	1.100
A1	0.000	-	0.150
A2	0.750	-	0.950
b	0.220	-	0.380
c	0.080	-	0.230
D	2.800	-	3.200
E	2.800	-	3.200
E1	4.650	-	5.150
e	0.650 BSC		
L	0.400	-	0.800
H	0.250 TYP		
θ	0°	-	8°
ccc	0.100		

NOTES:

1. This drawing is subject to change without notice.
2. The dimensions do not include mold flashes, protrusions or gate burrs.
3. Reference JEDEC MO-187.

TAPE AND REEL INFORMATION

REEL DIMENSIONS

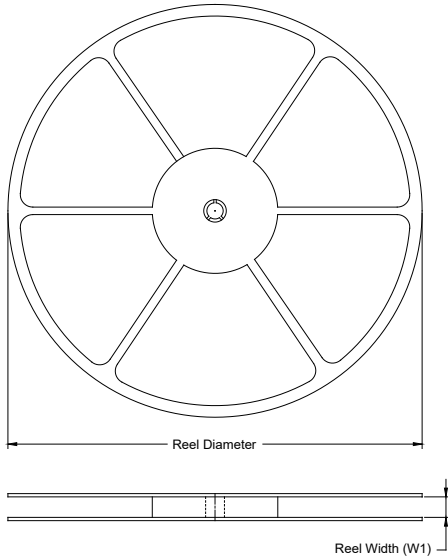

TAPE DIMENSIONS

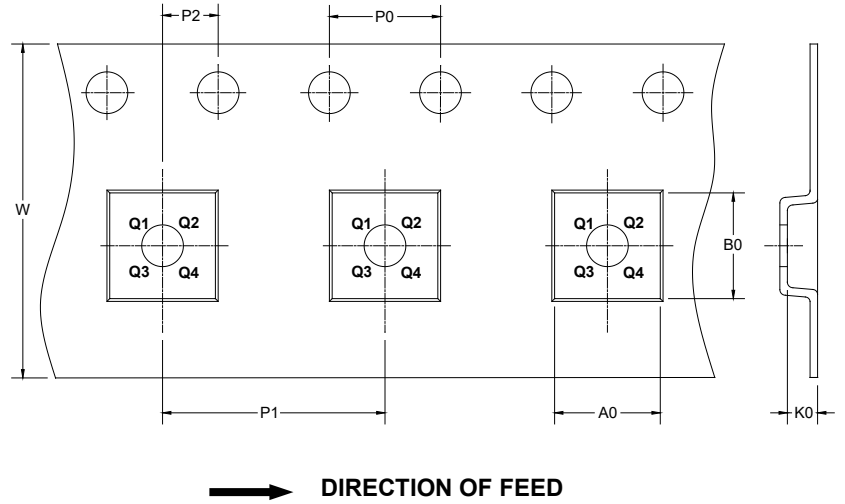

NOTE: The picture is only for reference. Please make the object as the standard.

KEY PARAMETER LIST OF TAPE AND REEL

Package Type	Reel Diameter	Reel Width W1 (mm)	A0 (mm)	B0 (mm)	K0 (mm)	P0 (mm)	P1 (mm)	P2 (mm)	W (mm)	Pin1 Quadrant
MSOP-8	13"	12.4	5.30	3.20	1.50	4.0	8.0	2.0	12.0	Q1

DD0001

# PACKAGE INFORMATION

## CARTON BOX DIMENSIONS

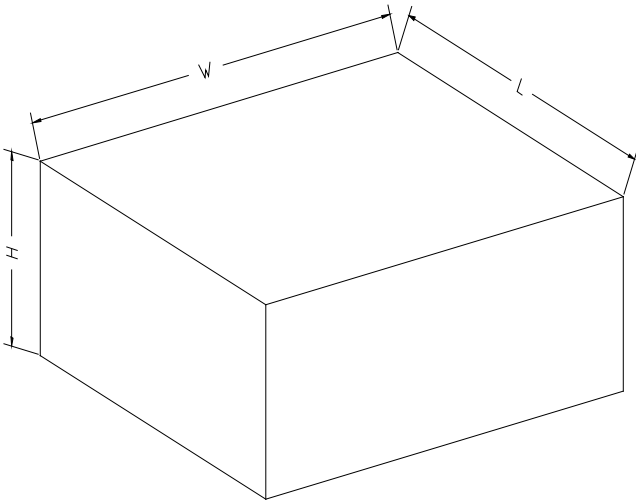

NOTE: The picture is only for reference. Please make the object as the standard.

## KEY PARAMETER LIST OF CARTON BOX

Reel Type	Length (mm)	Width (mm)	Height (mm)	Pizza/Carton
13"	386	280	370	5

DD0002