

GENERAL DESCRIPTION

The SGM62180 is a two-phase, synchronous Buck DC/DC converter with integrated power MOSFETs using two identical current balanced phases with peak current mode control. The SGM62180 is a perfect low profile solution for height restricted applications.

The Buck converter operates with phase delay to minimize the required input capacitance and reduce the EMI generation.

With a wide 4.5V to 16V input voltage range and a very low quiescent current (30µA), the SGM62180 is well suitable for systems powered by multi-cell Li-Ion batteries, particularly for 12V applications. It can deliver 6A continuous current which is equally shared between the phases. Dividing current between two phases allows the use of thinner inductors required for low profile designs.

The efficiency is automatically maximized in the full duty cycle range by adjusting the switching frequency to the optimal value depending on V_{IN} and V_{OUT} . The loss is also minimized at very light loads by the automatic activation of the power-save mode (PSM).

Other features include tracking, adjustable soft-start time, and power-good output signal. The SGM62180 can operate with 100% duty cycle for very low dropout. It is also capable to work at high step-down ratios without duty cycle limitation.

This device is available in a tiny 24-bump Green WLCSP package with 0.5mm pin pitch.

FEATURES

- Two-Phase with Phase Shift Operation
- Peak Current Controlled Constant Off-Time Mode
- Balanced Current Sharing
- Wide 4.5V to 16V Operating Input Voltage Range
- 0.9V to 6V Adjustable Output Voltage Range
- 6A Maximum Continuous Output Current
- 30µA (TYP) Low Quiescent Current
- Power-Save Mode (PSM) Operation in Light Loads
- Adjustable Soft-Start
- Voltage Tracking Capability
- Monotonic Start with Pre-biased Output
- Power-Good Output
- Hiccup Mode Over-Current Protection
- Over-Temperature Protection with Auto Recovery
- Available in a Green WLCSP-3.1×2.1-24B Package

APPLICATIONS

- Low Profile POL Supply
- Narrow Voltage DC (NVDC) Powered Systems
- Battery Powered Systems with Dual/Triple Li-Ion Cells
- Ultra-Portable and Embedded Tablet PC
- Computing Network Solutions
- Micro Servers, SSD

TYPICAL APPLICATION

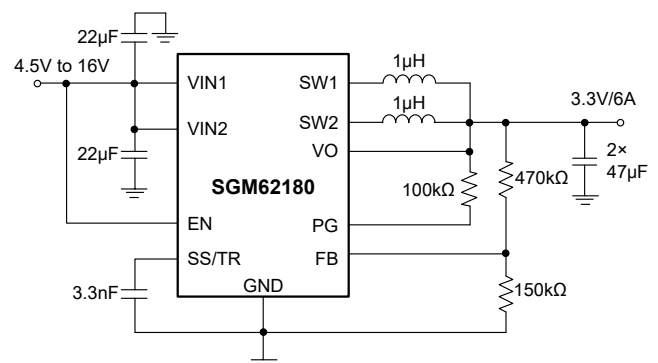

Figure 1. Typical Application Circuit

PACKAGE/ORDERING INFORMATION

MODEL	PACKAGE DESCRIPTION	SPECIFIED TEMPERATURE RANGE	ORDERING NUMBER	PACKAGE MARKING	PACKING OPTION
SGM62180	WLCSP-3.1×2.1-24B	-40°C to +125°C	SGM62180XG/TR	SGM 62180XG XXXXX XX#XX	Tape and Reel, 3000
	WLCSP-3.1×2.1-24B	-40°C to +125°C	SGM62180XSG/TR	SGM 62180XG XXXXX XX#XX	Tape and Reel, 6000

MARKING INFORMATION

NOTE: XXXXX = Date Code, Trace Code and Vendor Code, XX = Coordinate Information, # = Wafer ID Number.

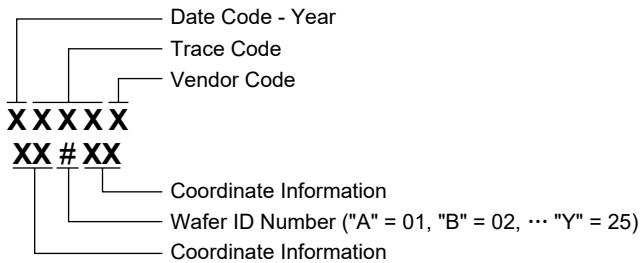

Green (RoHS & HSF): SG Micro Corp defines "Green" to mean Pb-Free (RoHS compatible) and free of halogen substances. If you have additional comments or questions, please contact your SGMICRO representative directly.

ABSOLUTE MAXIMUM RATINGS

VIN1, VIN2 Voltage.....	-0.3V to 17V
EN Voltage.....	-0.3V to VIN + 0.3V
PG Voltage	-0.3V to 12V
SW1, SW2 (DC) Voltage.....	-0.3V to VIN + 0.3V
SW1, SW2 (AC, Less than 10ns) Voltage.....	-2V to 24.5V
SS/TR Voltage	-0.3V to VIN + 0.3V, but ≤ 7V
FB, VO Voltage.....	-0.3V to 7V
Power-Good Sink Current.....	10mA
Package Thermal Resistance	
WLCSP-3.1×2.1-24B, θJA	70°C/W
Junction Temperature.....	+150°C
Storage Temperature Range	-65°C to +150°C
Lead Temperature (Soldering, 10s).....	+260°C
ESD Susceptibility	
HBM.....	2000V
CDM	1000V

RECOMMENDED OPERATING CONDITIONS

Input Voltage Range	4.5V to 16V
Output Voltage Range	0.9V to 6V
Maximum Output Current, IOUT_MAX	
0.9V ≤ VOUT ≤ 3.3V.....	6A (MIN)
3.3V < VOUT.....	6A (TYP)
Operating Junction Temperature Range.....	-40°C to +125°C

OVERSTRESS CAUTION

Stresses beyond those listed in Absolute Maximum Ratings may cause permanent damage to the device. Exposure to absolute maximum rating conditions for extended periods may affect reliability. Functional operation of the device at any conditions beyond those indicated in the Recommended Operating Conditions section is not implied.

ESD SENSITIVITY CAUTION

This integrated circuit can be damaged if ESD protections are not considered carefully. SGMICRO recommends that all integrated circuits be handled with appropriate precautions. Failure to observe proper handling and installation procedures can cause damage. ESD damage can range from subtle performance degradation to complete device failure. Precision integrated circuits may be more susceptible to damage because even small parametric changes could cause the device not to meet the published specifications.

DISCLAIMER

SG Micro Corp reserves the right to make any change in circuit design, or specifications without prior notice.

PIN CONFIGURATION

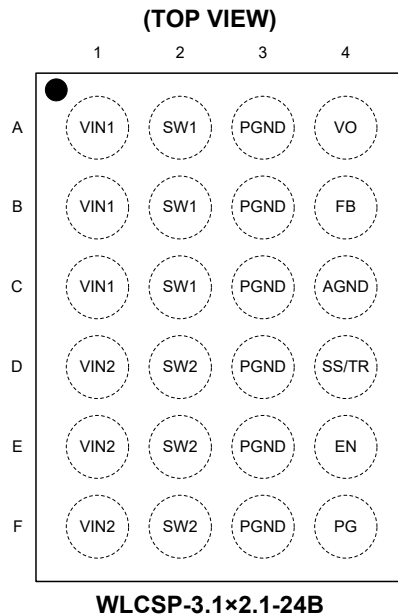

PIN DESCRIPTION

PIN	NAME	TYPE	FUNCTION
A1, B1, C1	VIN1	I	Supply Voltage for Phase 1 (Master) Converter.
A2, B2, C2	SW1	O	Switch Node for Phase 1 (Master). Connect L_1 between SW1 and the output capacitor.
A3, B3, C3, D3, E3, F3	PGND	G	Power Ground Pins.
A4	VO	O	Output Voltage Connection. Connect this pin to the converter output (near output capacitor).
B4	FB	I	Output Voltage Sense (Feedback) Pin. Connect the center node of the resistor divider between VO pin and AGND. Keep connecting traces short and away from high dv/dt signals.
D1, E1, F1	VIN2	I	Supply Voltage for Phase 2 (Slave/Follower).
D2, E2, F2	SW2	O	Switch Node for Phase 2 (Slave/Follower). Connect L_2 between SW2 and the output capacitor.
C4	AGND	G	Analog Ground. Connect it directly to PGND under the chip on the PCB. The AGND trace should not carry high current. The input, output and switching currents must travel through the PGND traces/planes.
D4	SS/TR	I/O	Soft-Start and Tracking Input. Use an external capacitor ($> 220\text{pF}$) between this pin and AGND to adjust the rise time of the output voltage ramp (soft-start time). V_{OUT} will follow and track the voltage applied to this pin if it is between 20mV and 1.2V ($V_{\text{FB}} = 0.64 \times V_{\text{SS/TR}}$).
E4	EN	I	Enable Input Pin (High = Enabled, Low = Disabled). EN can also be used to adjust the input UVLO.
F4	PG	O	Open-Drain Power-Good Output. PG = High means that V_{OUT} is in regulation and ready for the load system, and PG = Low means that V_{OUT} is below regulation. A pull-up resistor is needed if this feature is used.

NOTE: I: input, O: output, G = ground.

ELECTRICAL CHARACTERISTICS

(V_{IN} = 4.5V to 16V, T_J = -40°C to +125°C, typical values are tested at V_{IN} = 12V and T_J = +25°C, unless otherwise noted).

PARAMETER	SYMBOL	CONDITIONS	MIN	TYP	MAX	UNITS	
Supply							
Input Voltage Range	V _{IN}		4.5		16	V	
Operating Quiescent Current	I _Q	EN = High, I _{OUT} = 0mA, no switching, T _J = -40°C to +85°C		30	45	μA	
Shutdown Current	I _{SD}	EN = Low (≤ 0.3V), T _J = -40°C to +85°C		1.6	3	μA	
Under-Voltage Lockout Threshold ⁽¹⁾	V _{UVLO}	Falling input voltage	3.44	3.7	3.95	V	
		Hysteresis		270		mV	
UVLO Rising Delay				1		ms	
Thermal Shutdown	T _{SD}	Rising temperature		155		°C	
		Hysteresis		20			
Control (EN, SS/TR, PG)							
Rising Threshold Voltage (EN)	V _{H_EN}		0.96	1.03	1.10	V	
Falling Threshold Voltage (EN)	V _{L_EN}		0.86	0.93	1.00	V	
Input Leakage Current (EN)	I _{LKG_EN}	EN = V _{IN} = 15V		11	20	μA	
SS/TR Pin Source Current	I _{SS/TR}		4.4	5	5.6	μA	
Power-Good Threshold Voltage	V _{TH_PG}	Rising (%V _{FB})	93	96	99.5	%	
		Falling (%V _{FB})	89	92	95.5		
Power-Good Output Low Voltage	V _{OL_PG}	I _{PG} = -2mA		0.1	0.2	V	
Input Leakage Current (PG)	I _{LKG_PG}			0.01	0.3	μA	
Power Switch							
High-side MOSFET On-Resistance	R _{DSON}	V _{IN} = 7.5V	Phase 1		24	58	mΩ
			Phase 2				
Low-side MOSFET On-Resistance			Phase 1		13	27	mΩ
			Phase 2				
High-side MOSFET Current Limit	I _{LIM}	Each phase, V _{IN} = 7.5V	4.3	5.2	6.1	A	
Phase Shift Delay Time	t _{PSD}	Phase 2 after Phase 1, PWM mode		280		ns	
Minimum On Time				100		ns	
Maximum Duty Cycle				100		%	
Output							
Internal Reference Voltage	V _{REF}		0.790	0.800	0.811	V	
Input Leakage Current (FB)	I _{LKG_FB}	V _{FB} = 1V		0.01	0.2	μA	
Output Discharge Resistance	R _{DISCHARGE}	EN = Low		60		Ω	
Output Voltage Range		V _{IN} ≥ V _{OUT}	0.9		6	V	
Hiccup On-Time	t _{H_ON}			1		ms	
Hiccup Off-Time	t _{H_OFF}			5		ms	

NOTE:

1. The minimum V_{IN} value (4.5V) is not affected by UVLO threshold or hysteresis tolerances.

TYPICAL PERFORMANCE CHARACTERISTICS

$V_{IN} = 12V$, $V_{OUT} = 3.3V$ and $T_A = +25^\circ C$, unless otherwise noted.

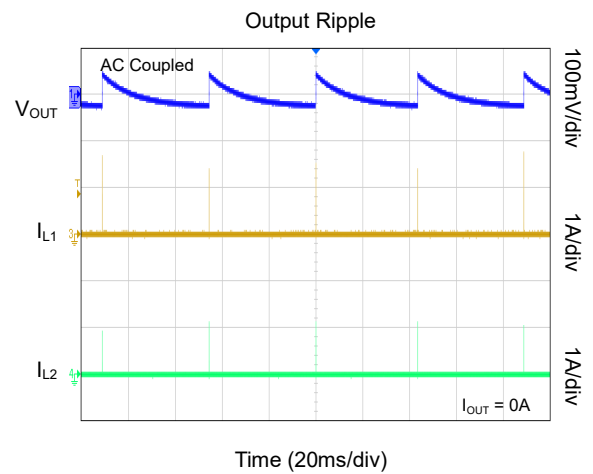
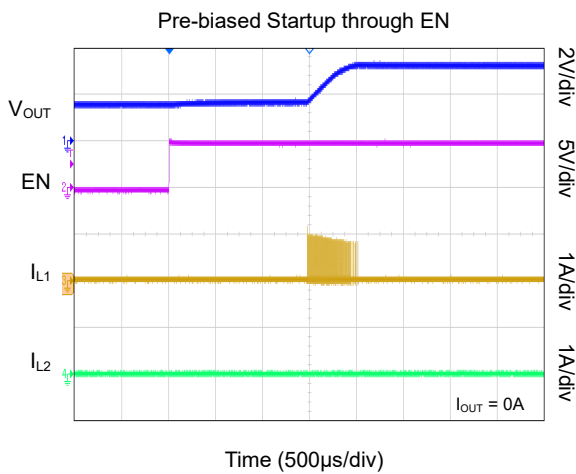
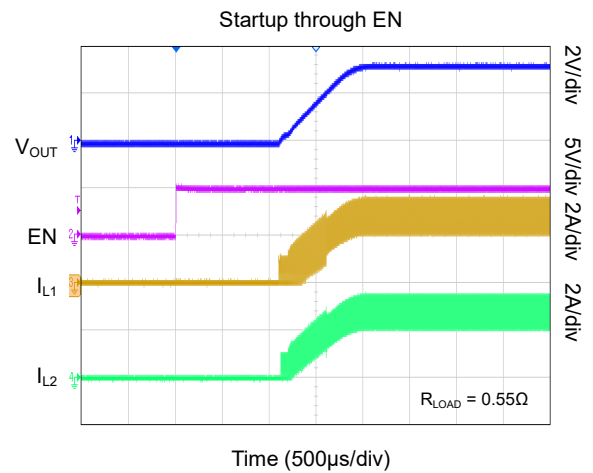
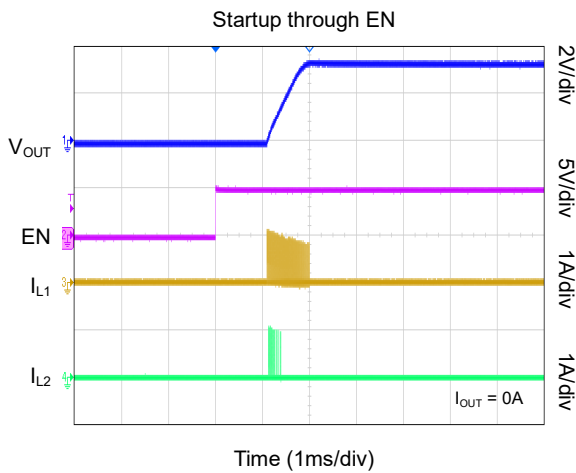
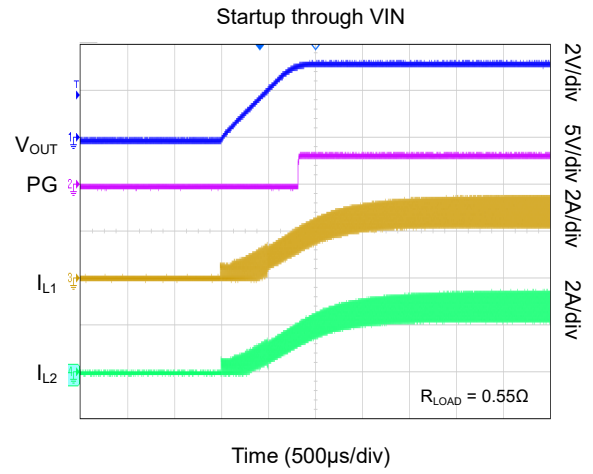
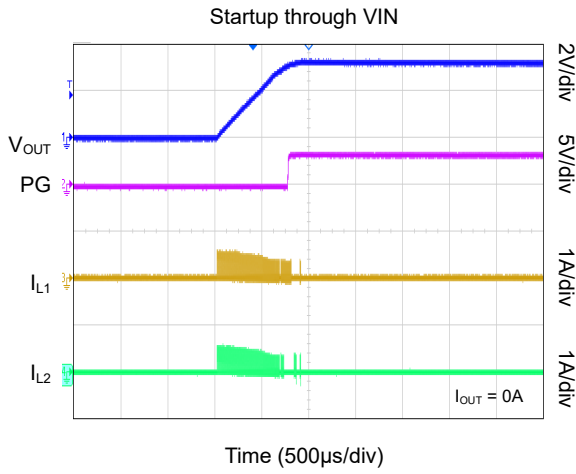

TYPICAL PERFORMANCE CHARACTERISTICS (continued)

$V_{IN} = 12V$, $V_{OUT} = 3.3V$ and $T_A = +25^\circ C$, unless otherwise noted.

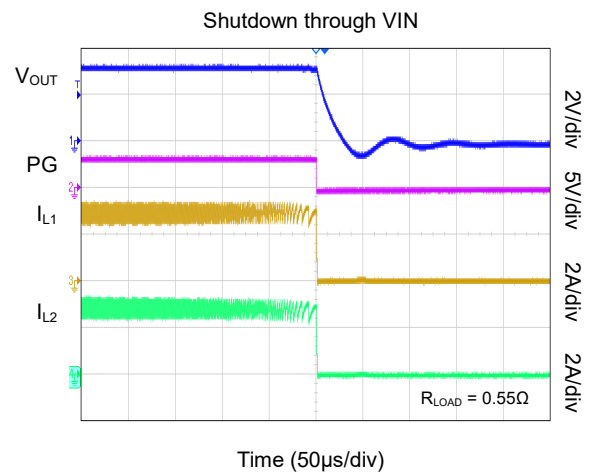
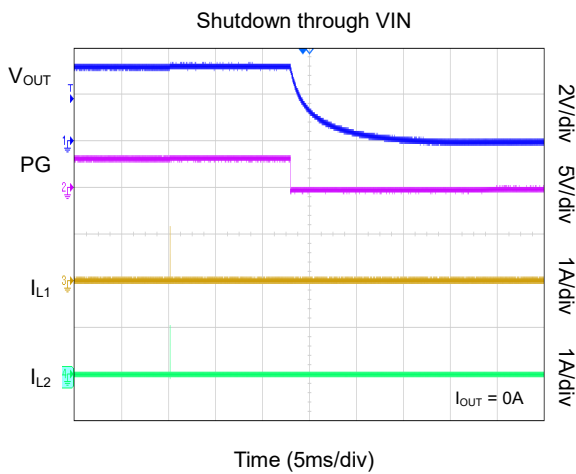
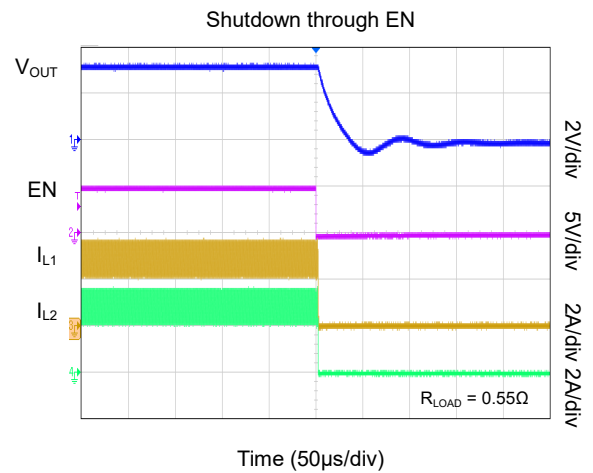
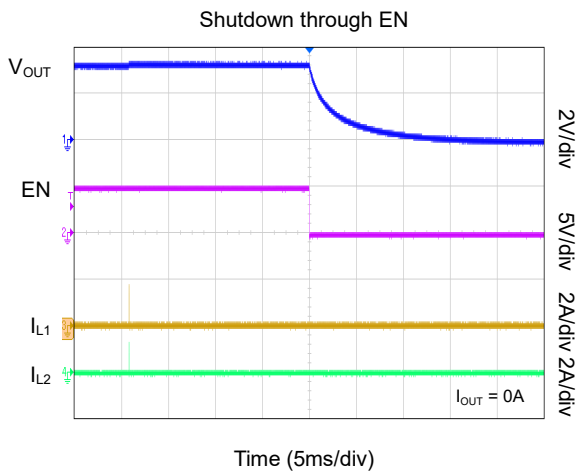
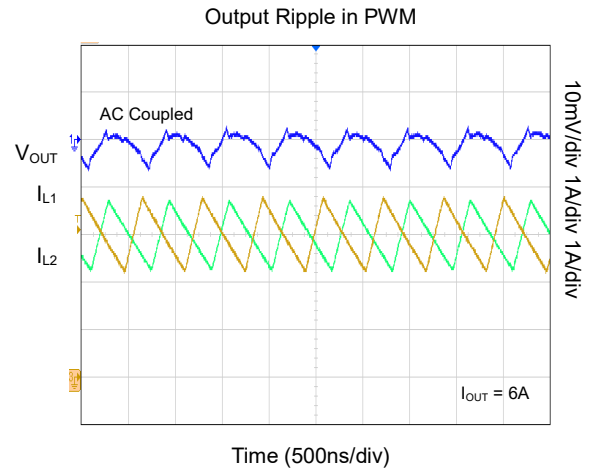
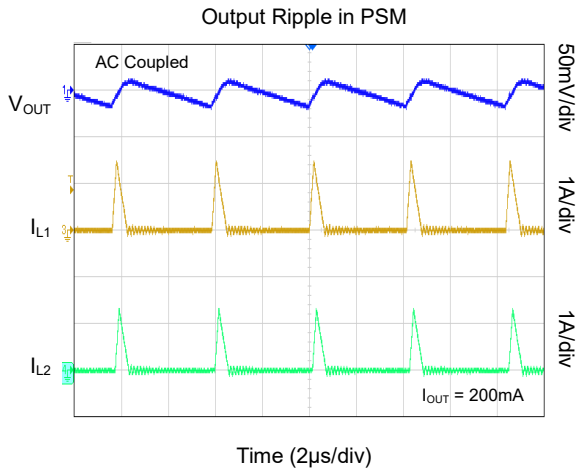

TYPICAL PERFORMANCE CHARACTERISTICS (continued)

$V_{IN} = 12V$, $V_{OUT} = 3.3V$ and $T_A = +25^\circ C$, unless otherwise noted.

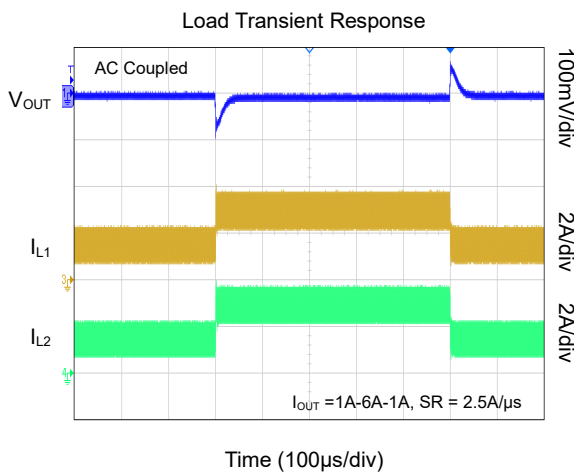
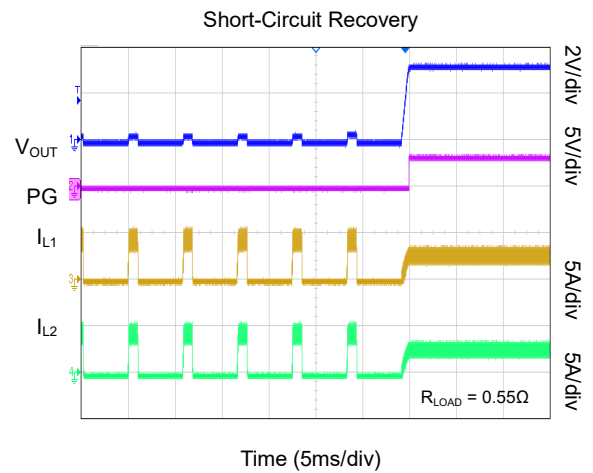
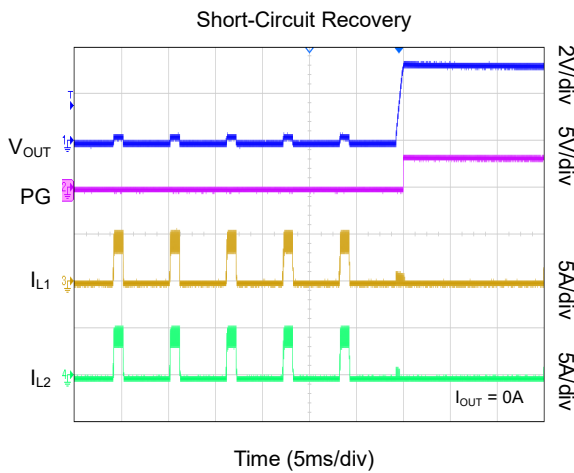
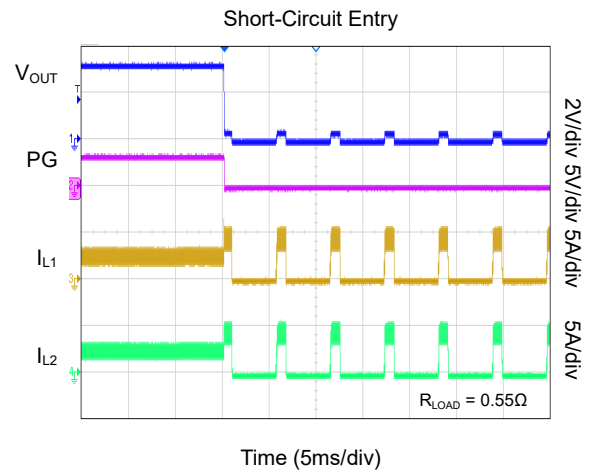
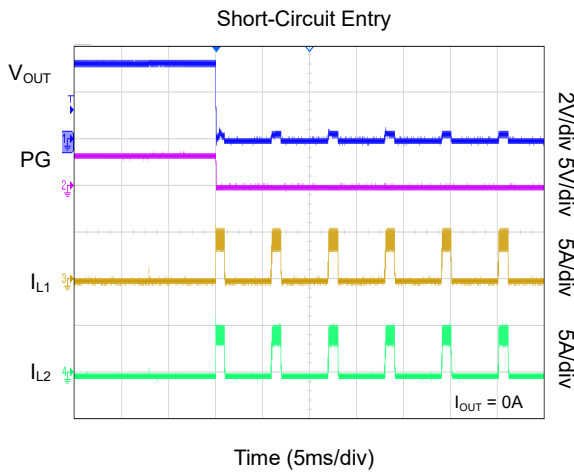

FUNCTIONAL BLOCK DIAGRAM

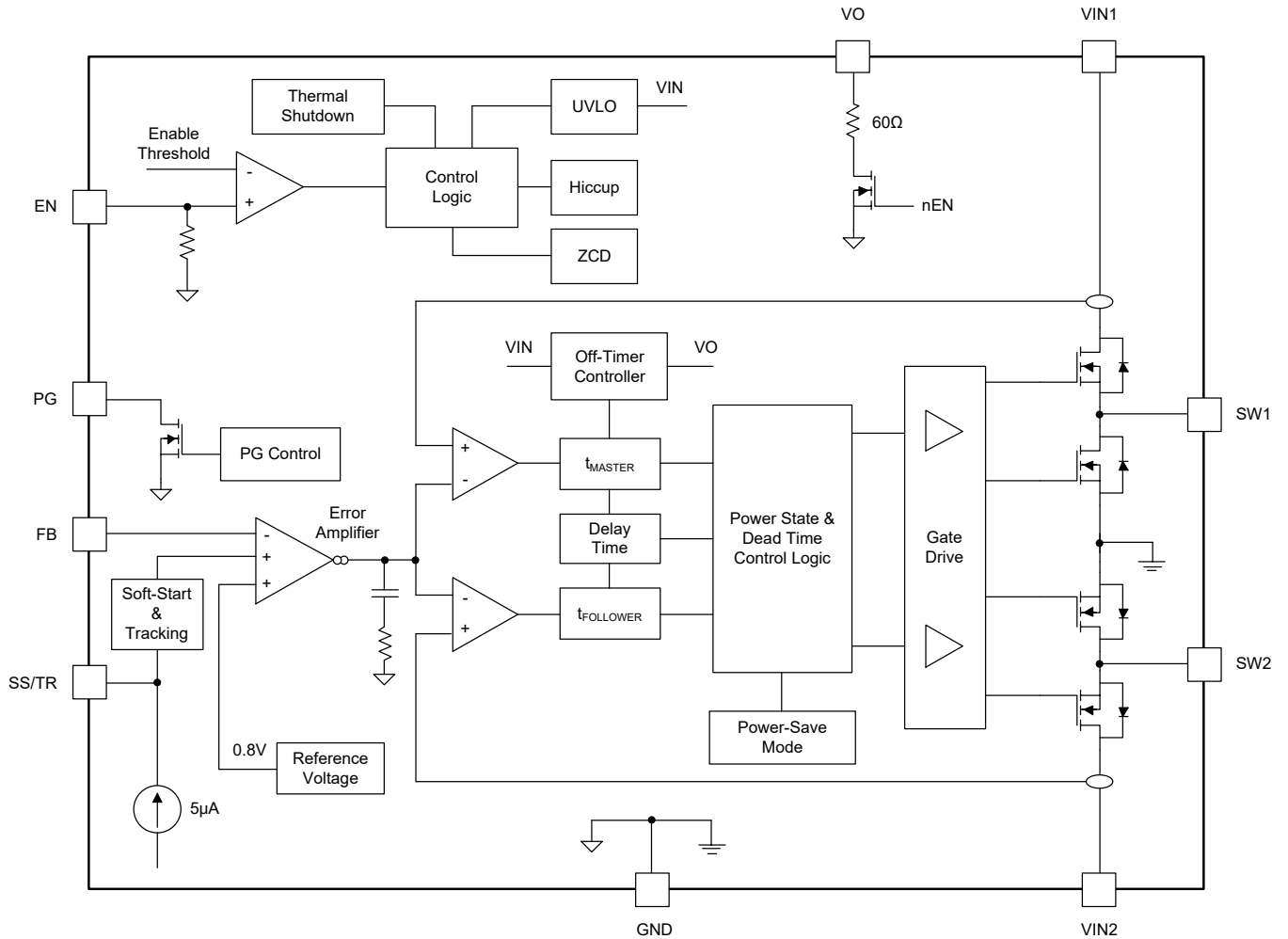

Figure 2. SGM62180 Functional Block Diagram

DETAILED DESCRIPTION

Overview

The SGM62180 is an efficient two-phase synchronous Buck converter with peak current mode control. It is a perfect choice for low-profile and minimal solution size designs which are typically needed in applications converting multi-cell Li-Ion sources to 0.9V to 6V outputs. The regulator is internally compensated. The inner current loop of each phase controls the peak inductor current in each cycle independently. The switching frequency is automatically adapted by an off-time controller to achieve efficiency maximization over the full load and duty cycle range, and also to change the operating mode into the PSM in light loads. In the steady state condition, the switching frequency is unchanged and is set depending on V_{IN} and V_{OUT} .

The load current is equally shared between the two phases of the SGM62180. The two phases are built identically and the control loop of the follower phase is connected with a fixed delay to the control loop of the master phase. Both phases have the same regulation thresholds and peak current set points to ensure a phase-shifted current-balanced operation. Due to this dual phase topology, the SGM62180 can provide continuous 6A output current in a very small solution size with high conversion performance.

Under-Voltage Lockout (UVLO)

The under-voltage lockout (UVLO) is a necessary feature to avoid malfunctioning of the internal circuits due to insufficient supply. If the input voltage falls below the UVLO threshold, the device will be shut down. The UVLO falling threshold is 3.7V (TYP). It has a 270mV hysteresis band (TYP) for turning on. There is a 1ms delay for enabling the device after V_{IN} exceeds the UVLO rising threshold. The power supply UVLO threshold can be adjusted above the 3.7V device threshold using the EN pin. See the Application Information section for details.

Enable/Shutdown (EN)

Conversion is started when a proper input voltage is present on V_{IN} and the enable input (EN) is set to high. The rising (1.03V) and falling (0.93V) thresholds are very convenient for precise on/off control, UVLO adjustment and power sequencing. It is also suitable for slow rising EN signals. The EN voltage can be pulled

down by a 350k Ω internal resistor to keep the device in off state if the EN pin is left open.

By pulling the EN voltage below 0.93V, the device is disabled, and a 60 Ω discharge resistor is connected between the output (VO) pin and ground.

To keep the device enabled, the EN pin can be connected to V_{IN} pin. In this case, a 1ms turn-on delay is inserted after V_{IN} exceeds V_{UVLO} and before soft-start (switching) ensures safe operation.

Power-Good (PG)

The power-good (PG) is an open-drain output that is provided to signal the status of the output voltage to the downstream system. The PG goes high when the V_{OUT} reaches to a narrow margin just below the programmed regulated output voltage. It will be pulled down immediately if the output goes out of regulation due to an overload or other reasons such as UVLO, thermal shutdown or disabling by EN pin. The PG pin can sink to around 2mA and must be pulled up by a resistor unless PG function is not used.

Table 1. Power-Good Pin Logic Table

Device Condition	PG State	
UVLO	$0.7V < V_{IN} < V_{UVLO}$	Low
Enable (EN = High)	$V_{FB} \geq V_{TH_PG}$	High-Z
	$V_{FB} \leq V_{TH_PG}$	Low
Shutdown (EN = Low)		Low
Thermal Shutdown	$T_J > T_{SD}$	Low
Power Supply Removal	$V_{IN} < 0.7V$	High-Z

Soft-Start/Tracking (SS/TR)

To avoid large inrush currents, this device is used for monotonic output ramp even in the presence of a pre-bias on the output. Limiting V_{OUT} slope also helps unwanted voltage drops if the input supply impedance is high. Every time the EN input goes high, the device switching is initiated and V_{OUT} starts to rise with a controlled slope. The rate is selected by an external capacitor (C_{SS}) connected between the SS/TR pin and AGND. The C_{SS} is charged by an internal 5 μ A current source. There is no limit for startup-time and large values can be selected. Do not float the SS/TR pin as it may cause overshoots on the output.

DETAILED DESCRIPTION (continued)

Equation 1 can be used to select the C_{SS} capacitor for a soft-start time of t_{SS} .

$$C_{SS} = t_{SS} \times \frac{5\mu A}{1.25V} \quad (1)$$

The SGM62180 has the capability to track an external voltage connected to the SS/TR pin. See the Tracking section for details.

Thermal Shutdown

To avoid damage from overheating, the junction temperature is continuously monitored. And if the temperature exceeds the shutdown level ($T_{SD} = +155^{\circ}C$, TYP), all power switches are turned off immediately and the discharge resistor is connected to the output. The PG is also pulled low. When the device is cooled off for $20^{\circ}C$ (typical hysteresis), the device automatically resumes normal operation after a soft-start.

Operating Modes

The SGM62180 output is regulated using a predictive off-time peak current mode control. With heavy loads, it works with PWM in the continuous conduction mode (CCM). But for light load, the converter starts to operate in discontinuous conduction mode (DCM) and the operation mode is switched to the PSM to minimize losses. The transition between PWM and PSM is automatically managed by the device.

Pulse Width Modulation Mode

In the PWM mode, the efficiency is maximized over the whole V_{IN} and V_{OUT} ranges by automatic adjustment of the off-time (t_{OFF}), based on the V_{IN} and V_{OUT} values. The predicted value is calculated by Equation 2:

$$t_{OFF} = \left(\frac{V_{IN}}{5 \times V_{OUT}} \times 500ns \right) + 50ns \quad (2)$$

While t_{OFF} is predicted from Equation 2, the on-time (t_{ON}) is determined by the required duty cycle:

$$t_{ON} = \frac{t_{OFF} \times V_{OUT}}{V_{IN} - V_{OUT}} \quad (3)$$

So, for any specific V_{IN} and V_{OUT} , the switching frequency is fixed and is determined by Equation 4:

$$f_s = \frac{1-D}{t_{OFF}} = \frac{1}{t_{OFF}} \times \left(1 - \frac{V_{OUT}}{V_{IN}} \right) \quad (4)$$

For example, when $V_{IN} = 12V$ and $V_{OUT} = 3.3V$, the switching frequency is $f_s = 1.75MHz$. And for $V_{OUT} = 1V$, it is 733kHz.

The master and follower phases have separate current control loops but use the same peak current set point for cycle by cycle peak current control and regulate their outputs to the same V_{OUT} level. Using the same current set points, the current peaks of the two phases are very well balanced and are not dependent on the inductor's DCR that may have large tolerances. The follower phase switches with a fixed delay after the master to get the phase shift advantages such as reduced input current ripple.

Power-Save Mode (PSM)

As the load is reduced, the internal error amplifier (EA) output is decreased. When it reaches to a preset fixed threshold, the light load condition is detected and the converter operation mode is changed from PWM to the PSM. In PSM, the converter frequency is reduced to minimize losses and the quiescent current. In this mode, the device employs a fixed peak current mode control technique, in which the peak current (I_{PEAK}) is determined by V_{IN} , V_{OUT} and L . In this technique, the HS switch is turned off when the inductor current reaches to the fixed peak threshold. And then the LS switch is turned on to conduct the inductor current. The HS switch will not turn on again until V_{OUT} falls to an internally preset low level (V_{OUT_LOW}). At very light loads, only one phase, either master or follower, may operate and remain active.

In PSM, the switching frequency can be calculated by Equation 5:

$$f_{PSM} = \frac{2 \times I_{OUT} \times V_{OUT} \times (V_{IN} - V_{OUT})}{L \times I_{PEAK}^2 \times V_{IN}} \quad (5)$$

It is clear that the switching frequency has a linear relationship with the output current in PSM.

DETAILED DESCRIPTION (continued)**100% Duty Cycle Mode**

The maximum on-time is not limited in the SGM62180. If $V_{IN} \approx V_{OUT}$, the device switches into the 100% duty cycle operation mode in which the HS switch is continuously kept on and the LS switch is kept off as long as V_{OUT} stays below its programmed value. The lowest V_{IN} value to keep the output regulation can be calculated from Equation 6:

$$V_{IN_MIN} = V_{OUT_MIN} + I_{OUT} \times \left(\frac{R_{DSON_HS}}{2} + DCR_{L1} \parallel DCR_{L2} \right) \quad (6)$$

The 100% duty cycle mode provides output regulation even with very small room that is specifically useful when the battery is depleted in the battery powered applications.

Automatic Efficiency Maximization (AEM)

The SGM62180 automatically adjusts the switching frequency to maximize its efficiency over the full input and output voltage range using the off-time predictive algorithm given in the Equation 2. Normally, the power losses of a switching converter are increased when the V_{OUT} is decreased and/or V_{IN} is increased. To reduce the losses (increase the efficiency), the switching frequency can be reduced when V_{IN} is high or V_{OUT} is low.

The efficiency enhancement is achieved over all duty cycles range. The efficiency improvement is especially noticeable at lower V_{OUT} values where the efficiency of a conventional fixed frequency converter drops significantly.

Moreover, by reducing the frequency at high V_{IN}/V_{OUT} ratios (small duty cycle), the on-time will remain above the marginal limits and the operating control range of the converter is extended. The minimum on-time for the high-side switches is about 100ns. Therefore, with the SGM62180 automatic efficiency maximization feature, operating at higher voltage ratios are possible compared with a similar fixed frequency converter.

Phase Shifting

There is an almost 280ns (TYP) fixed delay between the two phases in the PWM mode. Having a shift

between converter phases reduces the RMS of the switching pulse currents at the input of the converter that is supplied by the input capacitors. Because the input RMS current is reduced, smaller input capacitance is needed and the high frequency noise is reduced. In PSM, the phase shift is about 130ns when both phases are operating.

Current Protections

This device features current limiting, current balancing and short circuit protections. Peak current in each phase is limited independently but with equal levels. If the peak current limit is reached due to an overload or short circuit, the maximum current is provided for about 1ms and FB voltage decreases to 50% of the reference voltage. If the overload condition is not removed, the output starts hiccup and is turned off for about 5ms. After the 5ms off period, the device is restarted with a soft-start cycle. If the overload or short circuit condition is still present, the same hiccup cycle will repeat until the fault is removed.

Tracking

The SGM62180 has voltage tracking capability in which V_{OUT} can track the voltage applied at the SS/TR pin. The tracking input voltage of the SS/TR pin ranges from 50mV to 1.2V. The output is set such that the V_{FB} voltage is 0.64 times $V_{SS/TR}$ or:

$$V_{FB} \approx 0.64 \times V_{SS/TR} \quad (7)$$

The maximum $V_{SS/TR}$ that can be tracked is 1.25V. When the $V_{SS/TR}$ reaches near 1.2V, the SS/TR voltage will be internally clamped to 1/0.64 times of the reference voltage. And the output goes to the normal regulation. If the $V_{SS/TR}$ is reduced, the tracking will be started again, however, since the output does not sink current, V_{OUT} may slowly follow $V_{SS/TR}$, especially at light loads due to the output capacitor charges. The maximum voltage of SS/TR pin should never exceed its maximum rating of $V_{IN} + 0.3V$.

Note that if the $V_{FB} < 0.8V$, the output voltage tolerance can be lower than the specified accuracy.

APPLICATION INFORMATION

Typical Applications

The SGM62180 is a two phase synchronous Buck converter with 6A output current capability, 4.5V to 16V input voltage range and 0.9V to 6V programmable output voltage range. This device needs minimum number of external components as shown in Figure 3. The external components are: output filter L and C,

input capacitors, a small soft-start capacitor, output voltage programming resistor divider and an optional pull-up resistor for PG. The two-phase design allows using of two thin inductors rather than one large inductor and makes this device an excellent choice for low-profile applications.

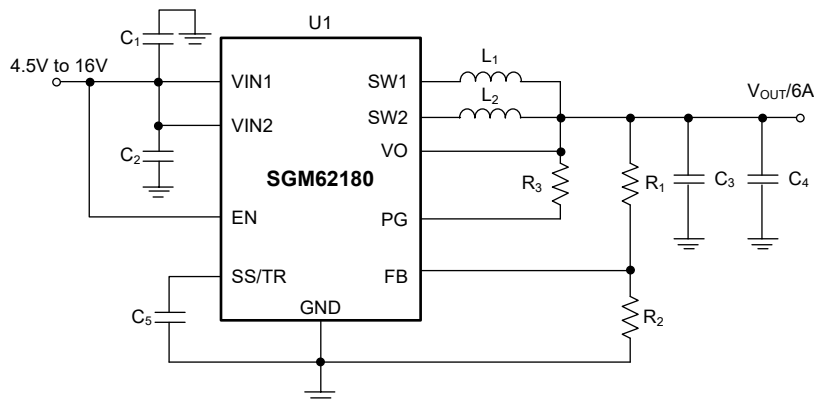

Figure 3. SGM62180 Typical 6A Converter with 4.5V to 16V Input

Design Requirements

Some design with SGM62180 for an overall solution size of < 99mm² and maximum height of 2.1mm is discussed. The selected components are listed in the following table.

Table 2. Components Used for High Efficiency Application Example

Reference Name	Description/Value	Manufacturer
C ₁ , C ₂	Ceramic capacitor GRM21BR61E226ME44, 2 × 22μF, 25V, X5R, 0805	muRata
C ₃ , C ₄	Ceramic capacitor GRM21BR1A476ME15L, 2 × 47μF, 10V, X5R, 0805	muRata
C ₅	Ceramic capacitor, 3.3nF, 10V, X5R, 0603	Standard
L ₁ , L ₂	Inductor XFL4020-102ME, 1μH ± 20%, 4 × 4 × 2.1mm	Coilcraft
R ₁	Chip resistor, value depending on V _{OUT}	Standard
R ₂	Chip resistor, value depending on V _{OUT}	Standard
R ₃	Chip resistor, 100kΩ, 0603, 5%	Standard
U1	SGM62180, 2 phase Buck converter, 3.1 × 2.1mm WLCSP	SGMICRO

APPLICATION INFORMATION (continued)

Detailed Design Procedure

Programming the Output Voltage

The center point of a resistor divider between V_{OUT} and AGND is connected to the FB pin to program the output voltage. The reference voltage is $V_{REF} = 0.8V$ and the V_{FB} which is calculated by $R_2 \times V_{OUT}/(R_1+R_2)$ is normally regulated to be equal to V_{REF} . The V_{OUT} output can be set between 0.9V to 6V. The R_1 and R_2 can be selected based on Equation 8:

$$\frac{R_1}{R_2} = \frac{V_{OUT}}{V_{FB}} - 1 \quad (8)$$

Larger resistors are preferred to improve light load efficiency, but using too large values reduces the noise immunity of the FB input. The bias currents may also affect the output accuracy. Set the divider current to 5 μ A for a good compromise, Equation 9 can be used to calculate R_2 :

$$R_2 = \frac{V_{FB}}{I_{FB}} = \frac{0.8V}{5\mu A} = 160k\Omega \quad (9)$$

And R_1 can be calculated from Equation 10:

$$R_1 = R_2 \times \left(\frac{V_{OUT}}{V_{FB}} - 1 \right) \quad (10)$$

For $V_{OUT} = 3.3V$, Equation 10 gives $R_1 = 500k\Omega$. The nearest standard resistor values are $R_1 = 470k\Omega$ and $R_2 = 150k\Omega$ that result in $V_{OUT} = 3.307V$ which is accurate enough. For more accurate output voltage, 0.1% resistors can be used.

If the FB pin is open or mistakenly programmed for large values, the internal clamp will limit the output voltage to about 7V.

Input Capacitor Selection

The input capacitor is needed for Buck converters to circulate the pulsating (AC) input current that is produced by the switching. Low ESR decoupling capacitors placed close to the VINx pins are critical for avoiding large voltage transients on the switches. They should have sufficient RMS current rating and be able to provide the peak currents. It is enough for most application with 2 \times 22 μ F (22 μ F on VIN1 and another one on VIN2 input) capacitors. They must be placed between VINx and nearby PGND pins and as close as possible to the device. Additional bulk capacitance may be added if required for the application. The worst-case effective capacitance must always remain above 2 \times 2 μ F (close to IC) + 10 μ F (bulk) on VIN pins to assure proper operation of the device. Low ESR multilayer ceramic capacitors are recommended for better filtering.

Output Filter Selection

The SGM62180 is internally compensated and is optimized for a range of LC values as provided in Table 3. The checked cells show the LC combinations that are proven for stability by lab tests and simulation. Other LC combinations must be tested if needed for specific applications. The given L and C values are nominal. The actual capacitance may have a +20% to -60% tolerance.

Table 3. Recommended LC Filter Nominal Values

V_{OUT} Value	Nominal L Value	Nominal C Value
$V_{OUT} \geq 1.8V$	1.0 μ H	2 \times 47 μ F
		4 \times 47 μ F
		6 \times 47 μ F
		8 \times 47 μ F
$V_{OUT} < 1.8V$	1.0 μ H	4 \times 47 μ F
		6 \times 47 μ F

Choose X5R or better grade ceramic dielectric types for input and output capacitors. Consider at least 25% room for voltage ratings. The 10V capacitors can be chosen for output capacitors to get lower thickness if capacitance reducing since the DC bias effect is acceptable for the application.

APPLICATION INFORMATION (continued)

Inductor Selection

Two 1μH inductors are normally chosen for the SGM62180. The DCR, saturation current and inductor height are the main parameters to choose depending on the required load current, efficiency and height restrictions. The ripple, RMS and peak inductor current calculations are summarized in Equations 11, 12 and 13 respectively.

$$\Delta I_L = \frac{V_{IN_MAX} - V_{OUT}}{L} \times \frac{V_{OUT}}{V_{IN_MAX} \times f_{SW}} \quad (11)$$

$$I_{L_RMS} = \sqrt{I_{OUT}^2 + \frac{\Delta I_L^2}{12}} \quad (12)$$

$$I_{L_PEAK} = I_{OUT} + \frac{\Delta I_L}{2} \quad (13)$$

The current flowing through the inductor is the inductor ripple current plus the output current. During power-up, faults or transient load conditions, the inductor current can increase above the calculated peak inductor current level calculated above. In transient conditions, the inductor current can increase up to the switch current limit of the device. For this reason, the most conservative approach is to specify an inductor with a saturation current rating equal to or greater than the switch current limit rather than the peak inductor current.

For low profile applications, a tradeoff between the physical inductor size and its losses are necessary. Normally, a smaller solution size is less efficient due to the higher DCR and/or core losses of the smaller inductors.

Output Capacitor Selection

Proper output capacitor selection is critical for the SGM62180 stability. C_{OUT} also determines transient response behavior and the magnitude of output ripple. In Table 4, the recommended output capacitor arrangements are provided for a range of output transient deviations in response to a 2A-6A-2A load step using 1μH inductors.

Low ESR ceramic capacitors with X5R or X7R (preferred) are recommended for the SGM62180 to get low output voltage ripple and temperature stable capacitance. Selecting higher output capacitance can provide tighter transient response and lower output voltage ripple. Larger C_{OUT} also improves the PSM output voltage accuracy. However, selecting a too large output capacitance may cause stability issues.

Table 4. Recommended Output Capacitor for SGM62180

V _{OUT} Value	Load Step	Nominal C Value ⁽¹⁾	Typical Transient Response Accuracy	
0.9V ⁽²⁾	2A-6A-2A ⁽³⁾	4 × 47μF	±100mV	±11%
1.8V ⁽²⁾	2A-6A-2A ⁽³⁾	2 × 47μF	±125mV	±7%
3.3V ⁽²⁾	2A-6A-2A ⁽³⁾	2 × 47μF	±165mV	±5%

NOTES:

- Due to the DC bias effect, the effective capacitance of the ceramic capacitors can drop significantly when the operating capacitor voltage is near the rated voltage depending on the selected package size, voltage rating and dielectric material.
- Use a 10pF feedforward capacitor, parallel to R₁, to improve stability and reduce output overshoots/undershoots caused by heavy load steps.
- The transient load step is tested with 1A/μs rising and falling slopes.

APPLICATION INFORMATION (continued)

Soft-Start Capacitor Selection

The soft-start time is set by a small external capacitor (C_{SS}) connected to the SS/TR pin. An internal $5\mu A$ current source charges the C_{SS} . The rising rate of the C_{SS} voltage determines the soft-start time as given by Equation 14:

$$C_{SS} = t_{SS} \times \frac{5\mu A}{1.25V} \quad (14)$$

Where t_{SS} is the soft-start ramp time in milli-seconds. For example, if $t_{SS} = 750\mu s$ is needed, the calculated C_{SS} will be $3nF$ and a standard $3.3nF$ capacitor can be used for C_{SS} . A minimum $220pF$ capacitor must be used for C_{SS} .

Do not leave SS/TR pin open to avoid output transients. The SS/TR pin may also be used as voltage input for output tracking as explained in the Tracking section.

Adjusting the UVLO Using Accurate EN Threshold

The accurate EN threshold voltage of the SGM62180 can be used to adjust the turn-on input voltage of the device using a resistive divider as shown in Figure 4.

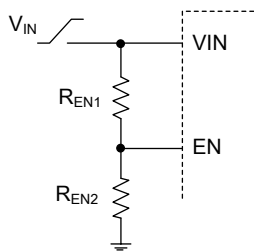

Figure 4. Adjusting UVLO by a Divider

The R_{EN1} and R_{EN2} are selected such that the EN = High level occurs at the desired V_{UVLO} level of the V_{IN} input. Use Equation 15 to calculate the divider resistors:

$$V_{UVLO} = V_{H_EN} \times \frac{R_{EN1} + R_{EN2} \parallel 350k\Omega}{R_{EN2} \parallel 350k\Omega} \quad (15)$$

Where V_{H_EN} ($1.03V$, TYP) is the rising threshold voltage of the EN pin. Consider a small current (e.g. $10\mu A$) in the divider at the nominal input voltage. For example, for an $8V$ input rail, choose $R_{EN1} + R_{EN2} \parallel 350k\Omega = 800k\Omega$. If the desired turn-on level is $5.5V$, the standard resistor values, derived from Equation 15, are $R_{EN1} = 634k\Omega$ and $R_{EN2} = 249k\Omega$. The device turns on when V_{IN} rises above $5.5V$ and turns off when input drops below $5.0V$ ($V_{L_EN} = 0.93V$, TYP).

Output Voltage Setting Design Examples

Some schematics for four common output voltage values ($0.9V$, $1.8V$, $3.3V$ and $5.0V$) are provided in Figure 5 to Figure 8.

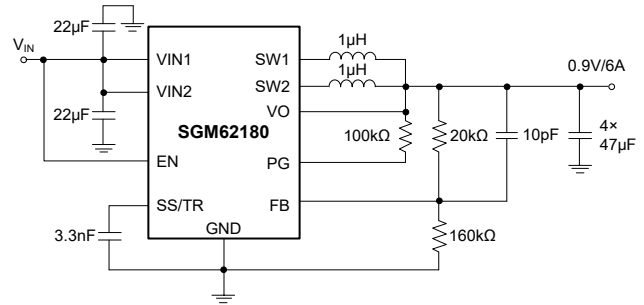

Figure 5. 0.9V/6A Power Supply

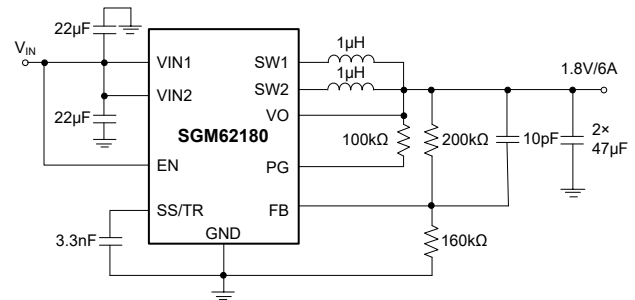

Figure 6. 1.8V/6A Power Supply

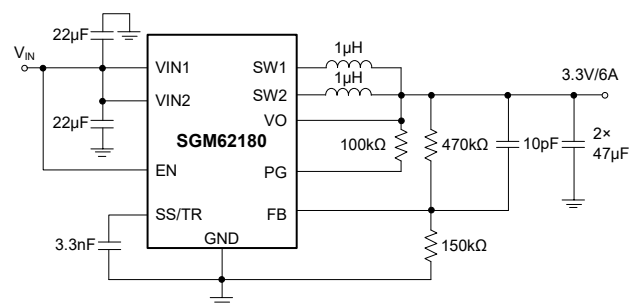

Figure 7. 3.3V/6A Power Supply

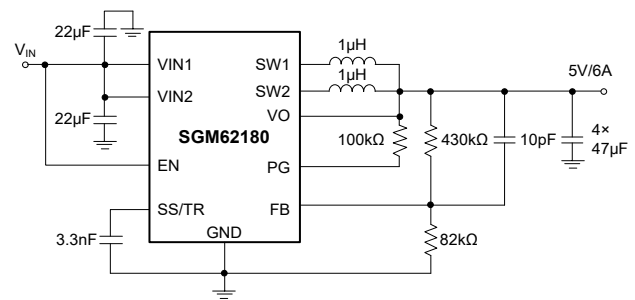

Figure 8. 5V/6A Power Supply

LAYOUT CONSIDERATIONS

Guidelines

To get a high performance power supply with the SGM62180, the PCB layout must be designed carefully with low noise and thermal relief considerations. Improper layout may result in poor performance in output regulation, stability, output accuracy, noise sensitivity and radiated EMI. Because the SGM62180 provides very high power density, the thermal design of the PCB for proper heat dissipation is critical for good thermal performance.

Layout

Figure 9 and Figure 10 show a recommended PCB layout for the SGM62180. This layout is designed based on the following important considerations to provide a very good electrical and thermal performance:

- (1) The input capacitors are placed as close as possible to the VINx and PGND pins to provide low resistive and inductive paths for the high di/dt input current. The input capacitance is split equally between VIN1 and VIN2 to avoid interference between the input lines.
- (2) The SW1 and SW2 connections from the device to the inductors are kept as short as possible with enough width to carry the output current.
- (3) The V_{OUT} regulation loop (FB) is routed close to the C_{OUT} and its ground connection. If the returns are through a ground plane in another layer, direct via connections are recommended, otherwise use the shortest path for C_{OUT} GND connection to avoid poor load regulation.
- (4) The FB node is sensitive to high dv/dt interference signals. Place the resistor divider as close as possible to the FB pin and avoid long traces in the divider network.

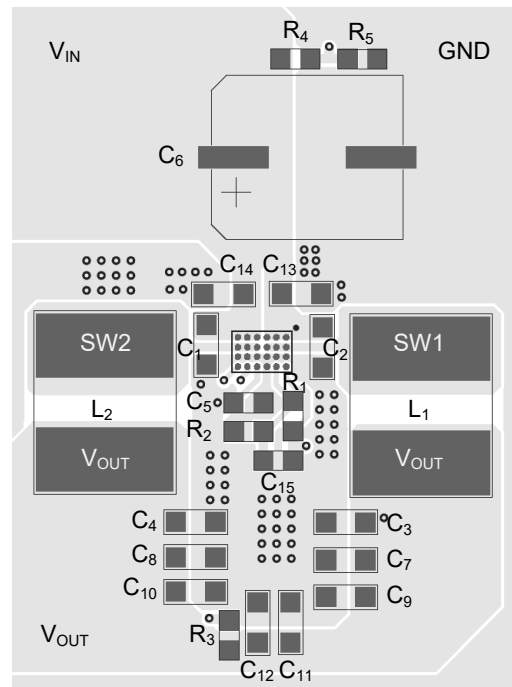

Figure 9. PCB Layout (Top View)

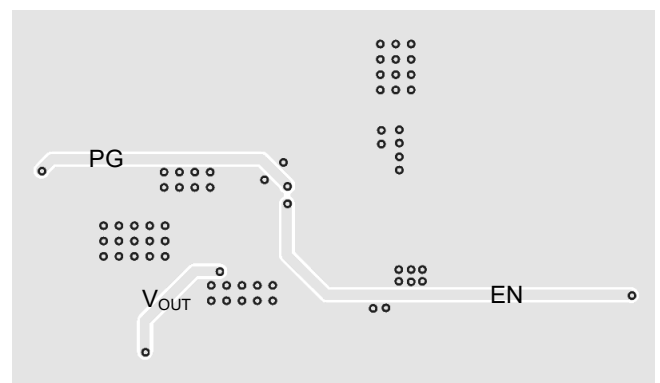

Figure 10. PCB Layout (Bottom View)

REVISION HISTORY

NOTE: Page numbers for previous revisions may differ from page numbers in the current version.

SEPTEMBER 2025 – REV.A.1 to REV.A.2	Page
Added SGM62180XSG/TR Model	2, 18

NOVEMBER 2022 – REV.A to REV.A.1	Page
Updated Application Information section.....	14

Changes from Original (SEPTEMBER 2022) to REV.A	Page
Changed from product preview to production data.....	All

PACKAGE OUTLINE DIMENSIONS

WLCSP-3.1×2.1-24B

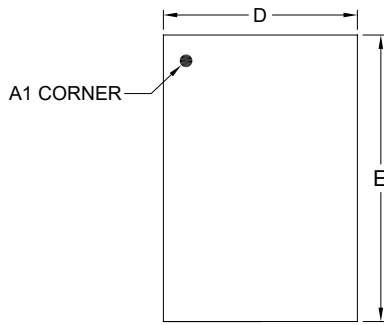

TOP VIEW

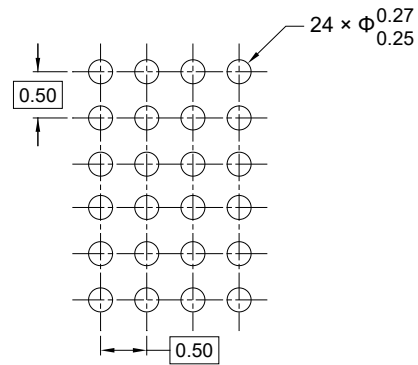

RECOMMENDED LAND PATTERN (Unit: mm)

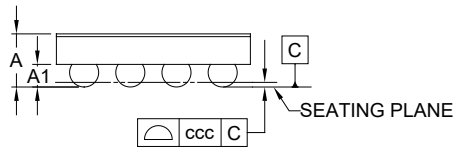

SIDE VIEW

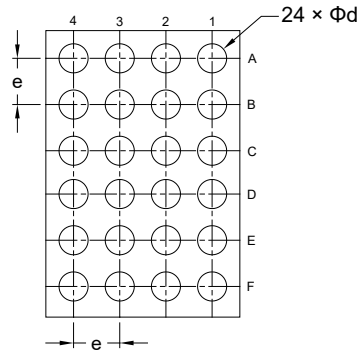

BOTTOM VIEW

Symbol	Dimensions in Millimeters		
	MIN	NOM	MAX
A	0.525	0.575	0.625
A1	0.215	0.245	0.275
D	2.070	2.100	2.130
E	3.070	3.100	3.130
d	0.280	0.315	0.350
e	0.500 BSC		
ccc	-	0.050	-

NOTE: This drawing is subject to change without notice.

PACKAGE INFORMATION

TAPE AND REEL INFORMATION

REEL DIMENSIONS

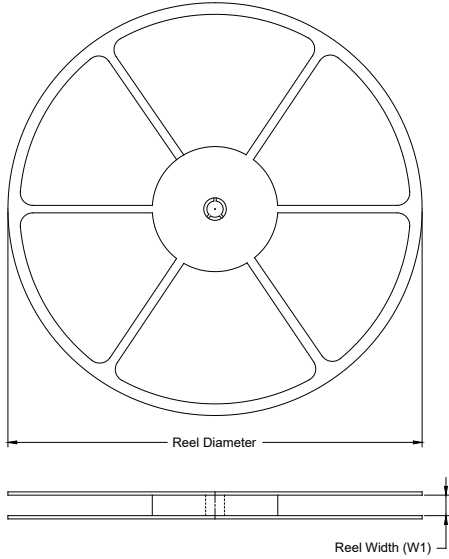

TAPE DIMENSIONS

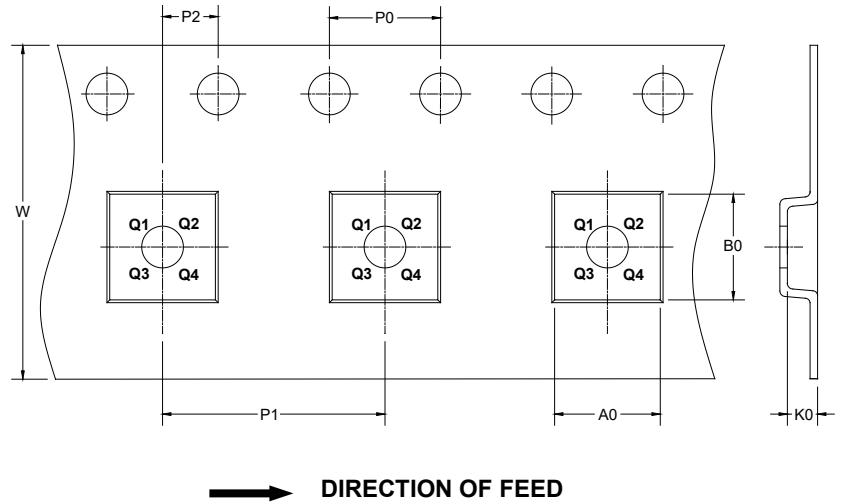

NOTE: The picture is only for reference. Please make the object as the standard.

KEY PARAMETER LIST OF TAPE AND REEL

Package Type	Reel Diameter	Reel Width W1 (mm)	A0 (mm)	B0 (mm)	K0 (mm)	P0 (mm)	P1 (mm)	P2 (mm)	W (mm)	Pin1 Quadrant
SGM62180XG/TR	13"	12.4	2.28	3.34	0.81	4.0	8.0	2.0	12.0	Q1
SGM62180XSG/TR	13"	12.4	2.28	3.28	0.80	4.0	4.0	2.0	12.0	Q1

DD0001

PACKAGE INFORMATION

CARTON BOX DIMENSIONS

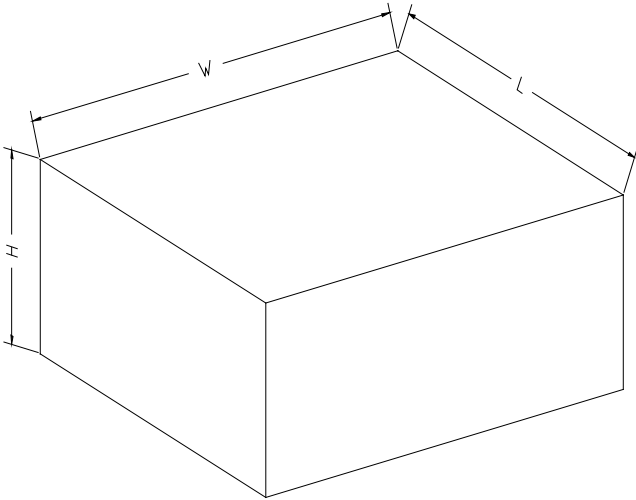

NOTE: The picture is only for reference. Please make the object as the standard.

KEY PARAMETER LIST OF CARTON BOX

Reel Type	Length (mm)	Width (mm)	Height (mm)	Pizza/Carton
13"	386	280	370	5

DD0002