

### GENERAL DESCRIPTION

SGM6627Q is a high-efficient Boost converter with high frequency. The device integrates a 0.13Ω power switch with 4.2A (TYP) current limit and supports an output voltage up to 18.5V. A pin selectable 650kHz or 1.2MHz switching frequency provides the device with fast transient response. This device also includes the built-in functions of soft-start, under-voltage lockout (UVLO) and thermal shutdown.

The device is AEC-Q100 qualified (Automotive Electronics Council (AEC) standard Q100 Grade 1) and it is suitable for automotive applications.

The SGM6627Q is available in a Green TDFN-3×3-10BL package.

### FEATURES

- **AEC-Q100 Qualified for Automotive Applications**  
**Device Temperature Grade 1**  
 $T_A = -40^{\circ}\text{C}$  to  $+125^{\circ}\text{C}$
- **2.5V to 5.5V Input Voltage Range**
- **Up to 18.5V Output Voltage**
- **4.2A (TYP) Current Limit**
- **650kHz/1.2MHz Selectable Switching Frequency**
- **Programmable Soft-Start**
- **Under-Voltage Lockout (UVLO)**
- **Thermal Shutdown**
- **Available in a Green TDFN-3×3-10BL Package**

### APPLICATIONS

- Automotive Body Electronics
- Automotive Infotainment Clusters
- Advanced Driver Assistance System (ADAS)
- Telemetry and Calling

### SIMPLIFIED SCHEMATIC

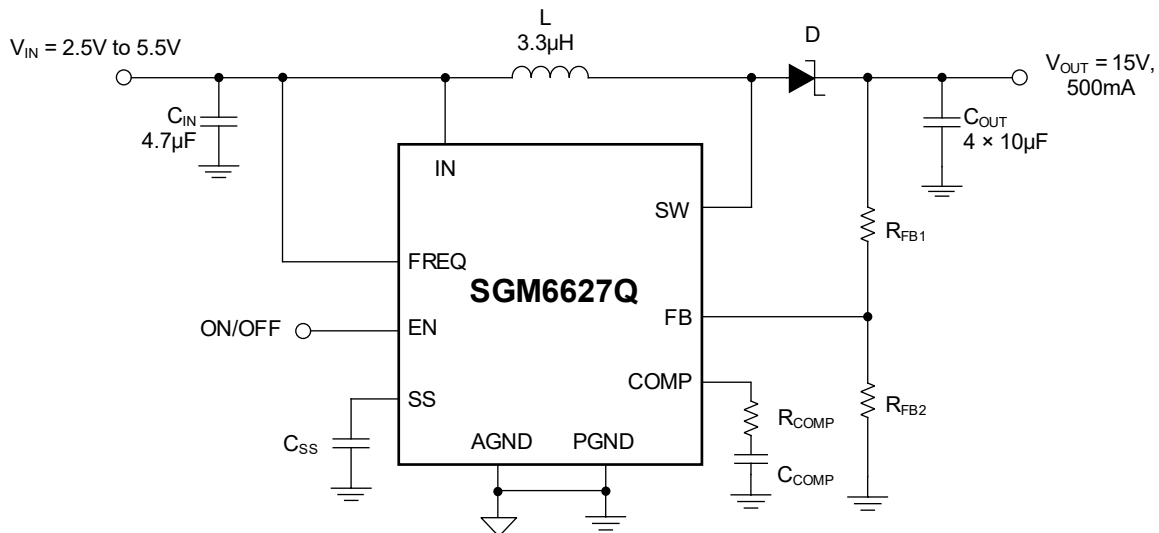

Figure 1. Simplified Schematic

**PACKAGE/ORDERING INFORMATION**

MODEL	PACKAGE DESCRIPTION	SPECIFIED TEMPERATURE RANGE	ORDERING NUMBER	PACKAGE MARKING	PACKING OPTION
SGM6627Q	TDFN-3×3-10BL	-40°C to +125°C	SGM6627QTHS10G/TR	1XS XXXXX XX#XX	Tape and Reel, 4000

**MARKING INFORMATION**

NOTE: XXXXX = Date Code, Trace Code and Vendor Code. XX#XX = Coordinate Information and Wafer ID Number.

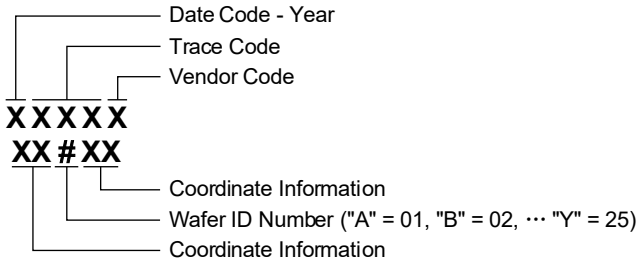

Green (RoHS & HSF): SG Micro Corp defines "Green" to mean Pb-Free (RoHS compatible) and free of halogen substances. If you have additional comments or questions, please contact your SGMICRO representative directly.

**ABSOLUTE MAXIMUM RATINGS**

Input Voltage Range .....	-0.3V to 6V
EN, FB, SS, FREQ, COMP .....	-0.3V to 6V
SW .....	-0.3V to 20V
Package Thermal Resistance	
TDFN-3×3-10BL, $\theta_{JA}$ .....	45.9°C/W
TDFN-3×3-10BL, $\theta_{JB}$ .....	18.8°C/W
TDFN-3×3-10BL, $\theta_{JC(TOP)}$ .....	44.4°C/W
TDFN-3×3-10BL, $\theta_{JC(BOT)}$ .....	8.3°C/W
Junction Temperature .....	+150°C
Storage Temperature Range .....	-65°C to +150°C
Lead Temperature (Soldering, 10s) .....	+260°C
ESD Susceptibility <sup>(1) (2)</sup>	
HBM .....	±3000V
CDM .....	±1000V

NOTES:

1. For human body model (HBM), all pins comply with AEC-Q100-002 specification.
2. For charged device model (CDM), all pins comply with AEC-Q100-011 specification.

**RECOMMENDED OPERATING CONDITIONS**

Input Voltage Range, $V_{IN}$ .....	2.5V to 5.5V
Boost Output Voltage Range, $V_{OUT}$ .....	$V_{IN} + 0.5V$ to 18.5V
Operating Junction Temperature Range .....	-40°C to +150°C

**OVERSTRESS CAUTION**

Stresses beyond those listed in Absolute Maximum Ratings may cause permanent damage to the device. Exposure to absolute maximum rating conditions for extended periods may affect reliability. Functional operation of the device at any conditions beyond those indicated in the Recommended Operating Conditions section is not implied.

**ESD SENSITIVITY CAUTION**

This integrated circuit can be damaged if ESD protections are not considered carefully. SGMICRO recommends that all integrated circuits be handled with appropriate precautions. Failure to observe proper handling and installation procedures can cause damage. ESD damage can range from subtle performance degradation to complete device failure. Precision integrated circuits may be more susceptible to damage because even small parametric changes could cause the device not to meet the published specifications.

**DISCLAIMER**

SG Micro Corp reserves the right to make any change in circuit design, or specifications without prior notice.

## PIN CONFIGURATION

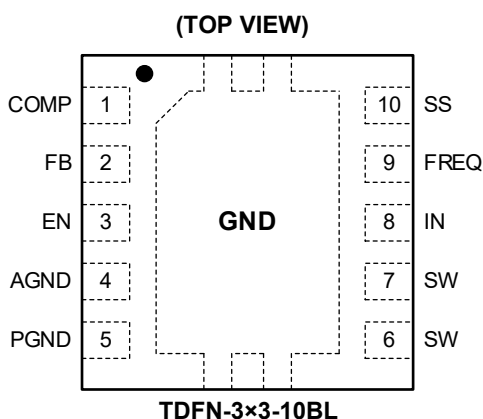

## PIN DESCRIPTION

PIN	NAME	TYPE	FUNCTION
1	COMP	I/O	Compensation Pin. Connect a capacitor and resistor in series.
2	FB	I	Feedback Input Pin. Feedback input to the error amplifier for regulated output.
3	EN	I	Enable Pin of the Boost Regulator. Logic low disables the chip and logic high enables it.
4	AGND	G	Analog Ground.
5	PGND	G	Power Ground.
6	SW	I	Switching Node of the Device.
7	SW	I	Switching Node of the Device.
8	IN	I	Supply Power Input Pin.
9	FREQ	I	Frequency Selection Pin. When FREQ is connected to GND, the device operates at 650kHz. When FREQ is connected to IN pin, the device operates at 1.2MHz.
10	SS	O	Soft-Start Control Pin. Connect a capacitor to this pin to set soft-start time. Open = no soft-start.
Exposed Pad	GND	G	Ground.

NOTE: I = input, O = output, I/O = input/output, G = ground.

**ELECTRICAL CHARACTERISTICS**(V<sub>IN</sub> = 5V, V<sub>EN</sub> = V<sub>IN</sub>, V<sub>OUT</sub> = 15V, T<sub>J</sub> = -40°C to +125°C, all typical values are measured at T<sub>J</sub> = +25°C, unless otherwise noted.)

PARAMETER	SYMBOL	CONDITIONS	MIN	TYP	MAX	UNITS
<b>Supply</b>						
Input Voltage Range	V <sub>IN</sub>		2.5		5.5	V
Operating Quiescent Current into IN Pin	I <sub>Q</sub>	Device not switching, V <sub>FB</sub> = 1.3V		70	110	μA
Shutdown Current into IN Pin	I <sub>SD_IN</sub>	EN = GND			1	μA
Under-Voltage Lockout Threshold	V <sub>UVLO</sub>	V <sub>IN</sub> falling			2.4	V
		V <sub>IN</sub> rising			2.5	V
Thermal Shutdown	T <sub>SD</sub>	Temperature rising		153		°C
Thermal Shutdown Hysteresis	T <sub>SD_HYS</sub>			12		°C
<b>Logic Signals of EN, FREQ</b>						
High-Level Input Voltage	V <sub>IH</sub>	V <sub>IN</sub> = 2.5V to 5.5V	1.2			V
Low-Level Input Voltage	V <sub>IL</sub>	V <sub>IN</sub> = 2.5V to 5.5V			0.4	V
Input Leakage Current	I <sub>IN_LEAK</sub>	EN = FREQ = GND			0.1	μA
<b>Boost Converter</b>						
Boost Output Voltage	V <sub>OUT</sub>		V <sub>IN</sub> + 0.5		18.5	V
Feedback Regulation Voltage	V <sub>FB</sub>		1.226	1.238	1.250	V
Transconductance Error Amplifier	gmEA			110		μA/V
Feedback Input Bias Current	I <sub>FB</sub>	V <sub>FB</sub> = 1.238V			0.1	μA
N-Channel MOSFET On-Resistance	R <sub>DSON</sub>	V <sub>IN</sub> = V <sub>GS</sub> = 5V, I <sub>SW</sub> = current limit		0.11	0.21	Ω
		V <sub>IN</sub> = V <sub>GS</sub> = 3V, I <sub>SW</sub> = current limit		0.14	0.24	
SW Leakage Current	I <sub>SW_LEAK</sub>	EN = GND, V <sub>SW</sub> = 6V			2	μA
N-Channel MOSFET Current Limit	I <sub>LIM</sub>		3.3	4.2	5.1	A
Soft-Start Current	I <sub>SS</sub>	V <sub>SS</sub> = 1.238V	9	11	13	μA
Switching Frequency	f <sub>SW</sub>	FREQ = V <sub>IN</sub> = 5V, V <sub>OUT</sub> = 15V, I <sub>OUT</sub> = 500mA	0.9	1.2	1.5	MHz
		FREQ = GND, V <sub>IN</sub> = 5V, V <sub>OUT</sub> = 15V, I <sub>OUT</sub> = 500mA	505	650	795	kHz
Line Regulation		V <sub>IN</sub> = 2.5V to 5.5V, I <sub>OUT</sub> = 10mA		0.0005		%/V
Load Regulation		V <sub>IN</sub> = 5V, I <sub>OUT</sub> = 1mA to 1A		0.25		%/A

TYPICAL PERFORMANCE CHARACTERISTICS

T<sub>A</sub> = +25°C, V<sub>IN</sub> = 5V, unless otherwise noted.

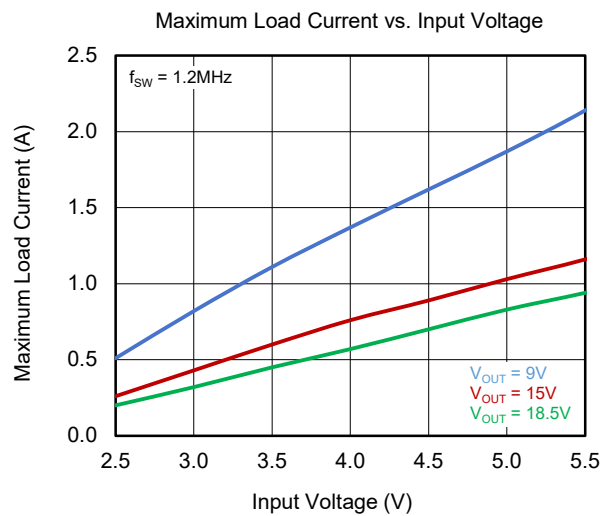
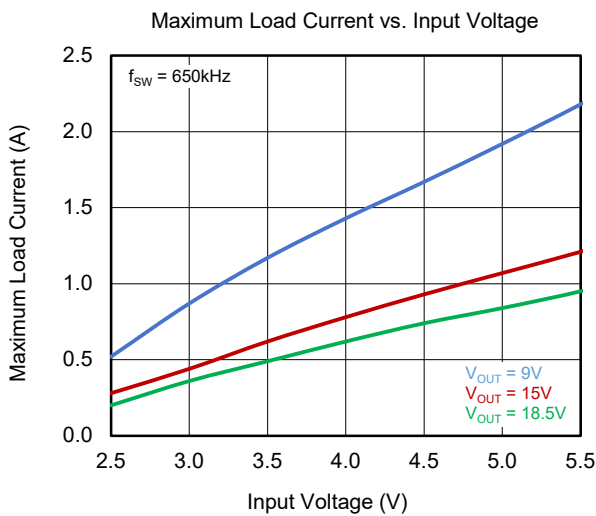
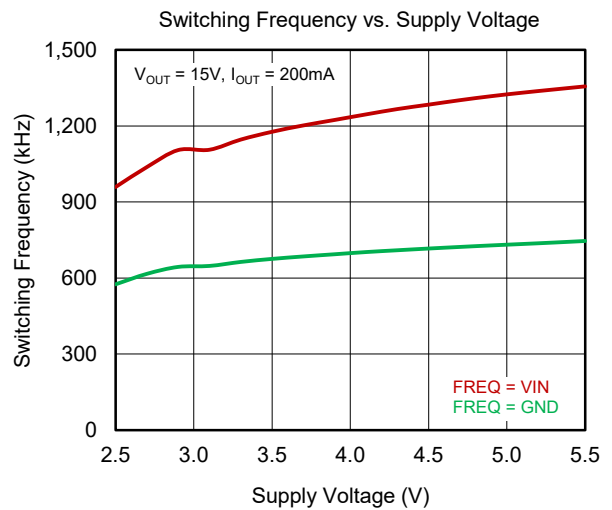
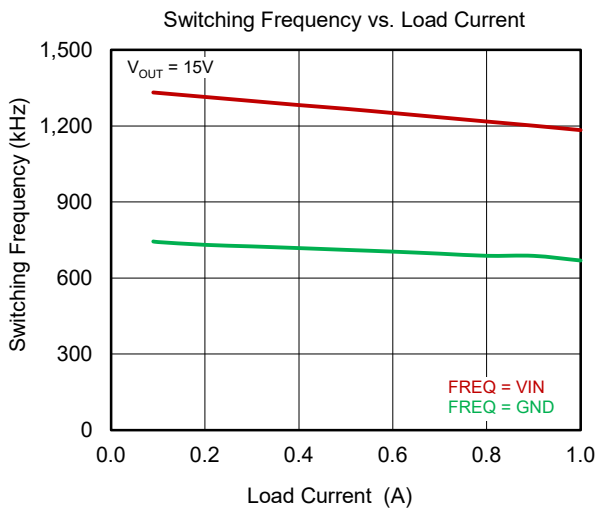
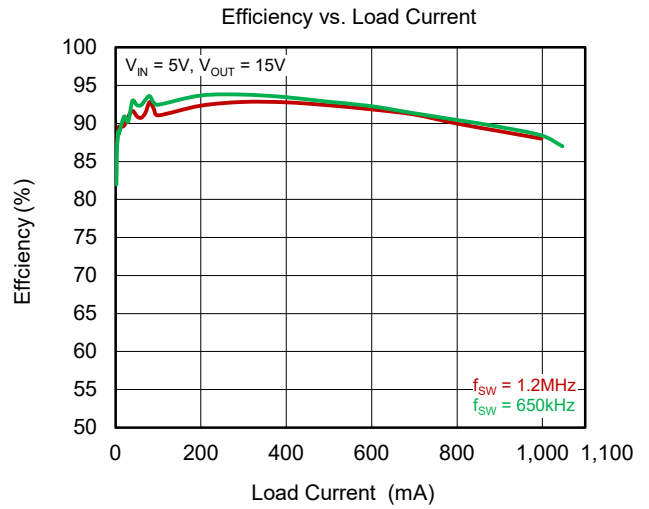
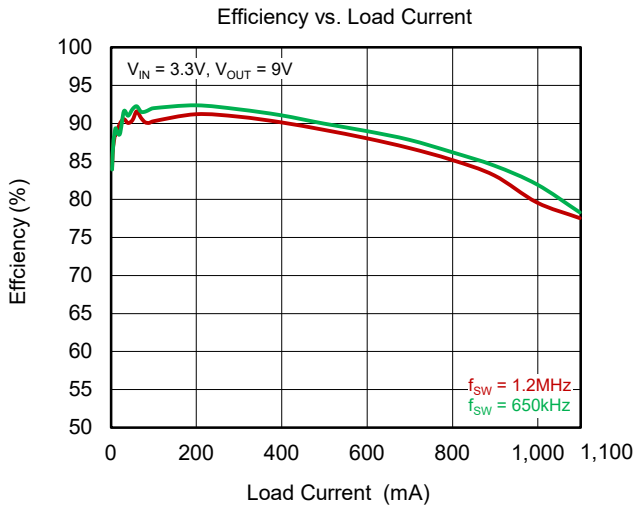

TYPICAL PERFORMANCE CHARACTERISTICS (continued)

T<sub>A</sub> = +25°C, V<sub>IN</sub> = 5V, V<sub>OUT</sub> = 15V, unless otherwise noted.

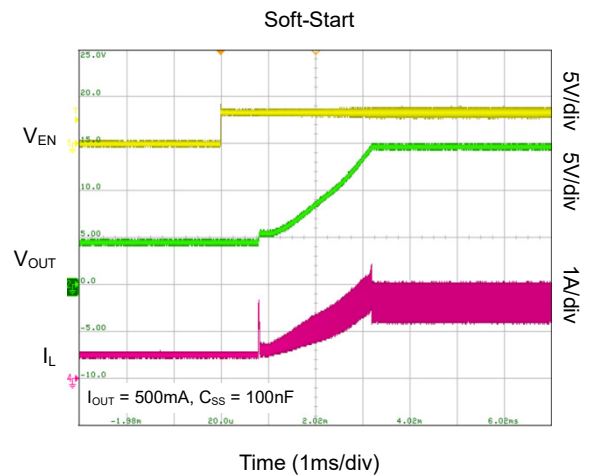
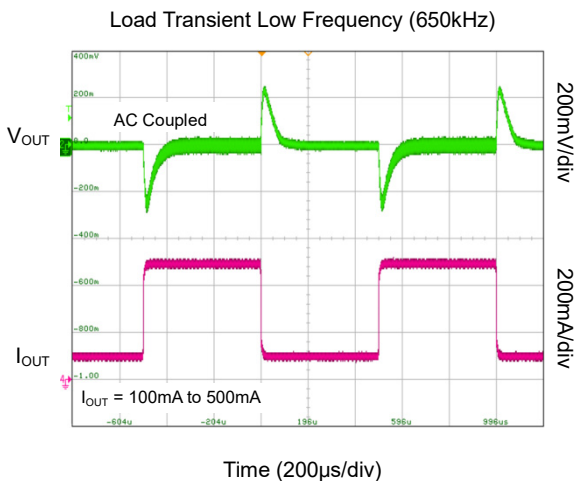
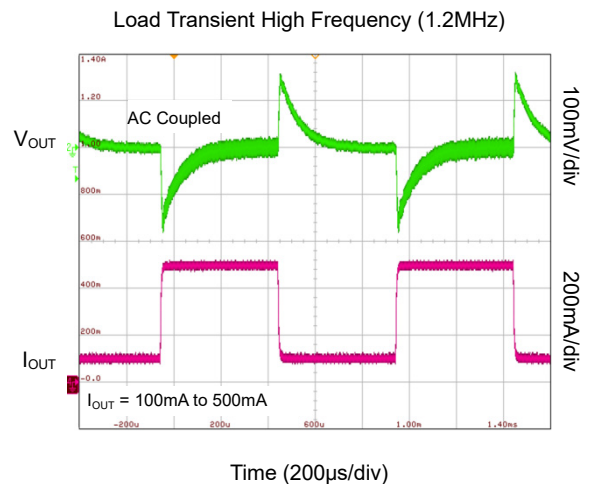
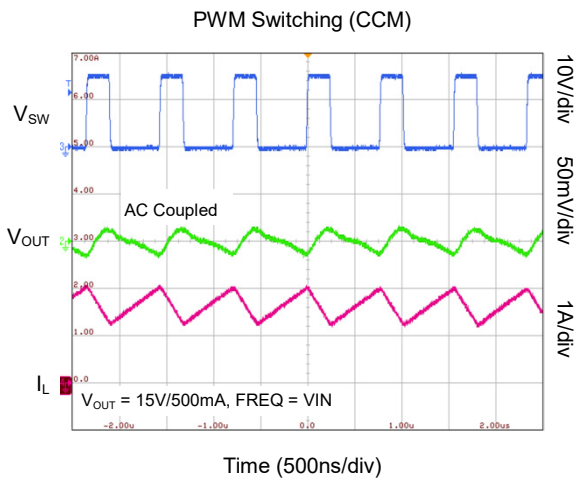
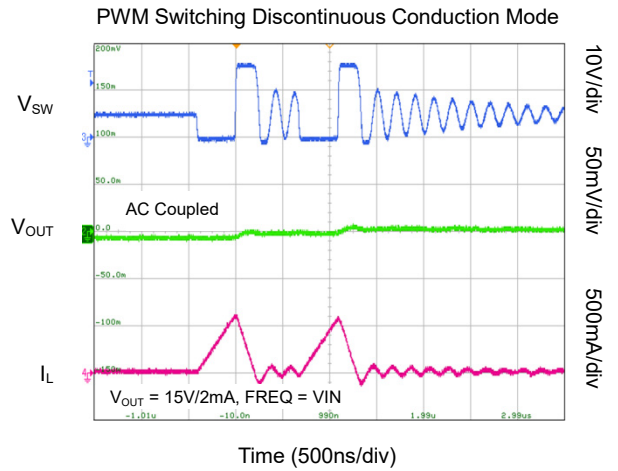
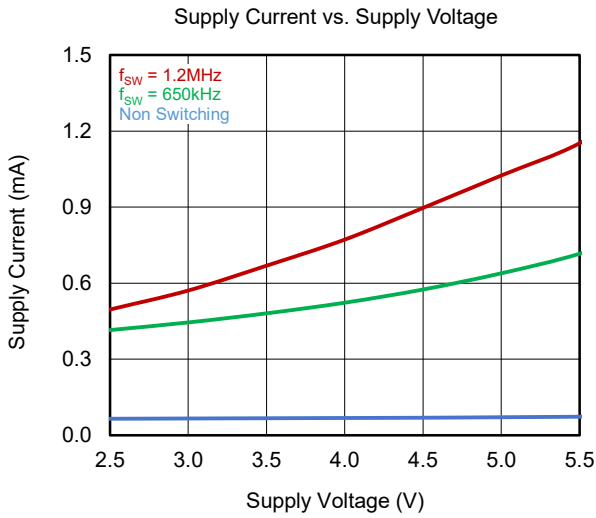

FUNCTIONAL BLOCK DIAGRAM

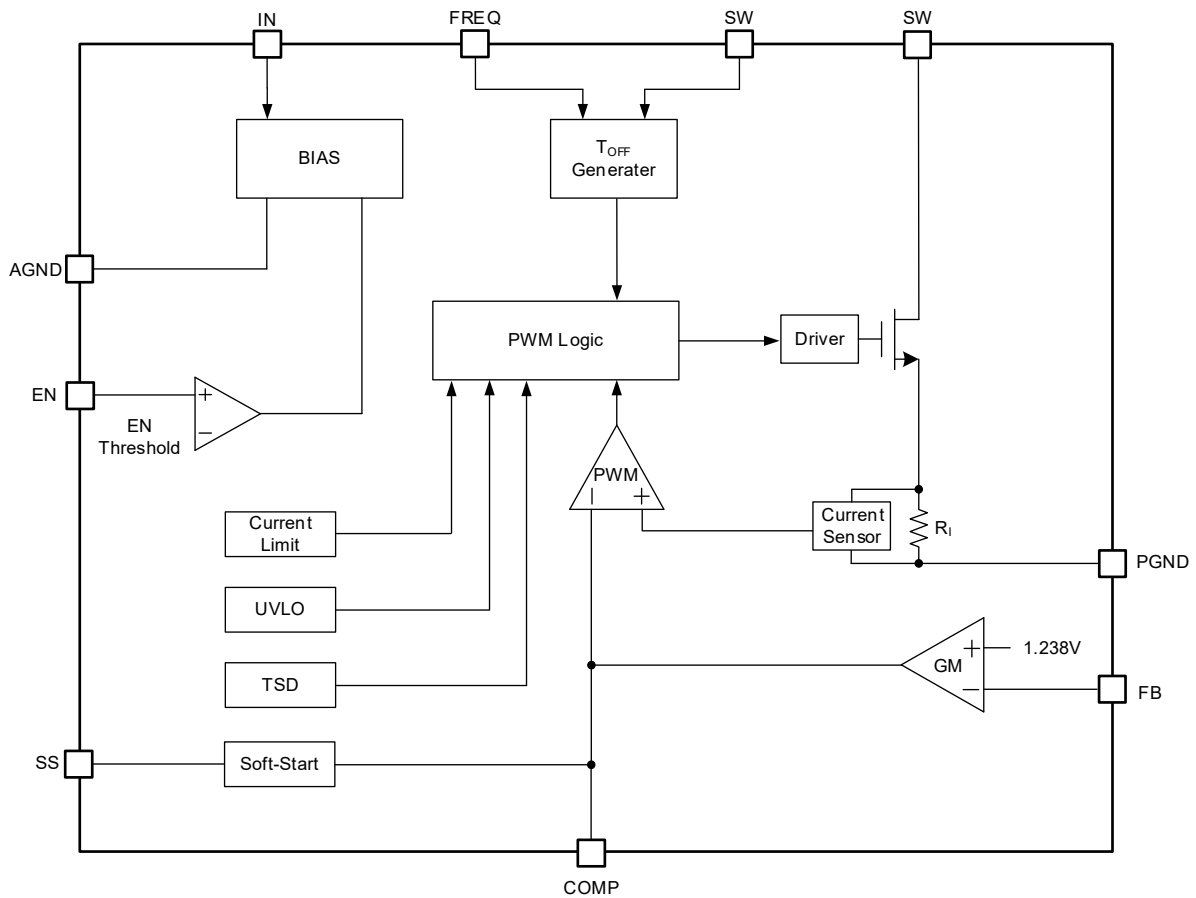

Figure 2. Block Diagram

## DETAILED DESCRIPTION

The SGM6627Q is a Boost DC/DC converter featuring an integrated low-side MOSFET switch and an adaptive constant off-time control scheme with quasi-constant frequency operation to regulate output voltages up to 18.5V. Designed for wide adaptability, it supports input voltages as low as 2.5V and delivers a peak current limit of 4.2A (TYP). The switching frequency is selectable between 650kHz and 1.2MHz via the **FREQ** pin. Its CFT control architecture ensures enhanced transient response to line and load variations, outperforming conventional control methods in dynamic scenarios.

The device operates in multiple modes to optimize efficiency under varying loads: continuous conduction mode (CCM) under heavy loads for high efficiency, discontinuous conduction mode (DCM) during light loads to minimize losses, and pulse-skip mode when the output load is extremely low to maintain output precision. A built-in soft-start mechanism suppresses inrush current during startup, ensuring reliable power-up sequences. These multi-mode operations, combined with rapid transient recovery, make the SGM6627Q suitable for applications demanding fast dynamic performance.

By integrating advanced control strategies and robust protection features, the SGM6627Q achieves broader application compatibility compared to traditional converters. Its ability to seamlessly transit between operational modes while maintaining voltage precision and efficiency underscores its versatility in both power-sensitive and high-performance environments.

### Soft-Start

The Boost converter employs an adjustable soft-start mechanism to mitigate inrush current during startup. This is achieved by connecting an external capacitor to the **SS** pin, which controls the gradual ramp up of the internal current limit. When the **EN** pin is activated (pulled high), the soft-start capacitor ( $C_{SS}$ ) is pre-charged to 0.6V and then charged with a constant 10 $\mu$ A current. During this phase, the **COMP** voltage follows the **SS** voltage, linearly adjusting the peak inductor current to ensure a gradual increase in the output voltage. Once the **FB** voltage reaches 98% of its nominal value, the **COMP** pin initiates closed-loop regulation, while the **SS** voltage continues to rise until it stabilizes at the **VIN** level.

The soft-start duration scales with  $C_{SS}$  capacitance (larger values prolong the ramp time) though 100nF typically suffices for most applications. Upon disabling the **EN** pin (pulled low),  $C_{SS}$  is actively discharged to

ground, resetting the startup sequence. This design balances controlled current limiting with minimal external component requirements.

### Frequency Select Pin (FREQ)

The switching frequency of the SGM6627Q is user configurable through its **FREQ** pin, which supports binary selection between two preset values: connecting the **FREQ** pin directly to **VIN** sets the operating frequency to 1.2MHz, while grounding the **FREQ** pin (**GND**) reduces the frequency to 650kHz.

A higher switching frequency can enhance the load transient response capability. This means the converter can better adapt to sudden changes in the load. However, it will cause a slight decrease in conversion efficiency. Additionally, operating in a high-frequency mode can reduce the output ripple voltage, which helps in providing a more stable output voltage.

### Under-Voltage Lockout (UVLO)

Under-voltage lockout protection (UVLO) monitors the **VIN** power input. When the voltage is lower than the UVLO threshold voltage, the device is shut down. This is a non-latched protection.

### Thermal Shutdown

The internal thermal shutdown protection turns off the device when the junction temperature exceeds +153°C (TYP). The chip will resume operation when the junction temperature drops by at least 12°C (TYP).

### Over-Voltage Prevention

The device incorporates an over-voltage protection mechanism that triggers when the **FB** pin voltage exceeds its threshold (typically 3% above the 1.238V). Once the OVP is triggered, the device stops switching immediately, preventing further voltage escalation to the output. This mechanism protects the device from potential damage caused by sudden load shedding or other factors from the downstream circuit.

### Device Functional Modes

The converter automatically adjusts its operating modes based on load conditions: it remains in continuous conduction mode (CCM) when the input current exceeds half the inductor ripple current. As the load current decreases, it transits to discontinuous conduction mode (DCM). Under extremely light loads, pulse skipping is activated to regulate the output voltage, ensuring efficient energy management across varying operational demands.

APPLICATION INFORMATION

The SGM6627Q supports output voltages up to 18.5V with a 4.2A peak current limit, utilizing current-mode control and quasi-fixed frequency for stable operation. Its switching frequency is adjustable between 650kHz and 1.2MHz, with an input range of 2.5V to 5.5V, while

external compensation ensures adaptability and stability. A dedicated soft-start pin controls inrush current during startup, and the subsequent guide outlines a simplified process to configure the IC as a Boost converter for voltage regulation.

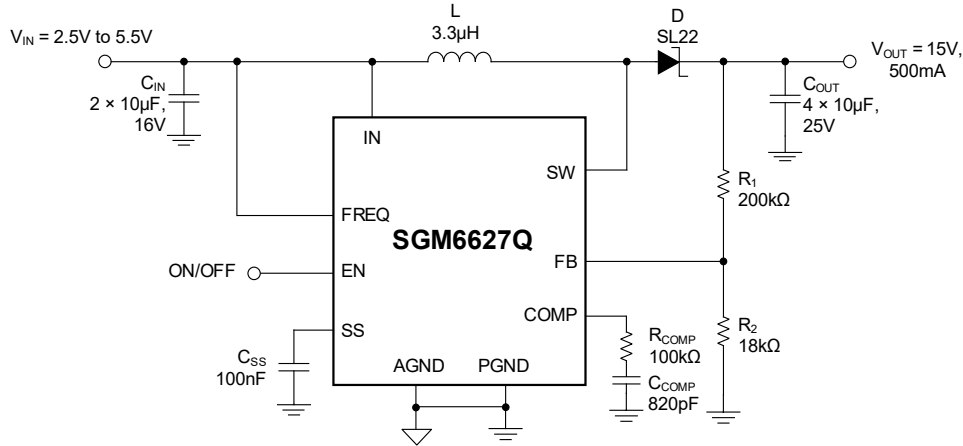

Figure 3. f<sub>sw</sub> = 1.2MHz, Application Circuit

Design Requirements

For this design example, use the parameters shown in Table 1.

Table 1. Design Parameters

PARAMETER	EXAMPLE VALUE
Input Voltage	2.5V to 5.5V
Output Voltage	15V
Output Current	500mA
Switching Frequency	1.2MHz

Detailed Design Procedure

The design procedure begins by confirming the Boost converter’s peak output current capability aligns with system requirements. This validation can be performed through provided efficiency curve for preliminary calculations.

Duty cycle (D) is calculated with Equation 1.

$$D = 1 - \frac{V_{IN} \times \eta}{V_{OUT}} \tag{1}$$

Maximum output current (I<sub>OUT\_MAX</sub>) is calculated with Equation 2.

$$I_{OUT\_MAX} = \left( I_{LIM\_MIN} - \frac{\Delta I_L}{2} \right) \times (1 - D) \tag{2}$$

Peak switch current in application (I<sub>SW\_PEAK</sub>) is calculated with Equation 3.

$$I_{SW\_PEAK} = \frac{\Delta I_L}{2} + \frac{I_{OUT}}{1 - D} \tag{3}$$

The inductor peak-to-peak ripple current (ΔI<sub>L</sub>) is calculated with Equation 4.

$$\Delta I_L = \frac{V_{IN} \times D}{f_s \times L} \tag{4}$$

where, V<sub>IN</sub> is the minimum input voltage. V<sub>OUT</sub> is the output voltage. I<sub>LIM\_MIN</sub> is the converter switch current limit (minimum switch current limit = 3.3A). f<sub>sw</sub> is the converter switching frequency (typically 1.2MHz or 650kHz). L is the selected inductor value. η is the estimated converter efficiency (use the number from the efficiency plots or 90% as an estimation).

**APPLICATION INFORMATION (continued)**

**Inductor Selection**

The SGM6627Q is available with a wide range of inductors, prioritizing two key criteria: saturation current and DC resistance. The inductor’s saturation current must exceed the calculated peak switch current (Equation 3) with sufficient margin for load spikes, or alternatively match/exceed the 5.1A maximum switch current limit for conservative designs. Lower DC resistance typically enhances efficiency, though core material, type, and high-frequency losses (core losses, skin/proximity effects at 1.2MHz) also significantly impact the performance. Larger inductors generally yield higher efficiency, with variations of 2% to 10% between models. Recommended values are 3µH to 6µH (3.3µH typical) at 1.2MHz, or 6µH to 13µH (6.8µH typical) for 650kHz operation. Engineers must verify inductor selections against their specific application requirements using Table 2 to ensure optimal performance.

It is recommended that the inductor current ripple is below 35% of the average inductor current. Equation 5 can be used to calculate the inductor value (L).

$$L = \left( \frac{V_{IN}}{V_{OUT}} \right)^2 \times \left( \frac{V_{OUT} - V_{IN}}{I_{OUT} \times f_s} \right) \times \left( \frac{\eta}{0.35} \right) \quad (5)$$

where,  $I_{OUT}$  is the maximum output current in the application.

**Table 2. Inductor Selection**

INDUCTOR VALUE	TYPICAL DCR	ISAT	SUPPLIER	SIZE (L × W × H mm <sup>3</sup> )	COMPONENT CODE
<b>1.2MHz</b>					
4.7µH	7.9mΩ	15.5A	Würth Elektronik	12.1 × 11.4 × 9.5	7443320470
3.3µH	5.7mΩ	22.4A	Würth Elektronik	12.1 × 11.4 × 9.5	7443320330
<b>650kHz</b>					
6.8µH	11mΩ	12.9A	Würth Elektronik	12.1 × 11.4 × 9.5	7443320680

**Table 3. Rectifier Diode Selection**

I <sub>AVG</sub>	V <sub>R</sub>	V <sub>FORWARD</sub>	SUPPLIER	COMPONENT CODE
2A	20V	0.44V	Vishay Semiconductor	SL22
2A	20V	0.5V	Fairchild Semiconductor	SS22

**Rectifier Diode Selection**

To achieve high efficiency, a Schottky diode is strongly recommended for rectification purposes. The reverse voltage rating of the Schottky should exceed the maximum output voltage of the Boost converter, while its average forward current rating must match the converter’s output current ( $I_{OUT}$ ). These parameters ensure reliable operation under both voltage and load conditions.

$$I_{AVG} = I_{OUT} \quad (6)$$

A Schottky diode rated for 2A average forward current is typically adequate for general use. Lower current diodes may be viable if aligned with the output current, provided their power dissipation capacity meets operational requirements. Typically the power dissipation on the diode must be around 500mW. The power dissipation of the Schottky diode is calculated by following equation:

$$P_D = I_{AVG} \times V_{FORWARD} \quad (7)$$

Table 3 lists the recommended Schottky diode for most application.

**APPLICATION INFORMATION (continued)**

**Setting the Output Voltage**

The output voltage is configured via an external resistive divider. To ensure precision and noise immunity, a feedback divider current  $\geq 50\mu\text{A}$  is typically recommended. For typical application, an 18kΩ resistor is used as a bottom resistor.

The resistors are then calculated as shown in Equation 8:

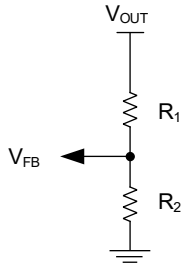

$$R_2 = \frac{V_{FB}}{70\mu\text{A}} \approx 18\text{k}\Omega$$

$$R_1 = R_2 \times \left( \frac{V_S}{V_{FB}} - 1 \right)$$

$$V_{FB} = 1.238\text{V} \tag{8}$$

**Compensation (COMP)**

The regulator loop compensation can be optimized by modifying the external components connected to the COMP pin, which functions as the output terminal of the internal transconductance error amplifier.

Equation 9 can be used to calculate  $R_{COMP}$  and  $C_{COMP}$ .

$$R_{COMP} = \frac{110 \times V_{IN} \times V_{OUT} \times C_{OUT}}{L \times I_{OUT}}$$

$$C_{COMP} = \frac{V_{OUT} \times C_{OUT}}{7.5 \times I_{OUT} \times R_{COMP}} \tag{9}$$

where,  $C_{OUT}$  is the output capacitance.

Make sure that  $R_{COMP} < 120\text{k}\Omega$  and  $C_{COMP} > 820\text{pF}$ , independent of the results of the above formulas.

Table 4 lists the specialized compensation networks that can improve the load transient response for different application conditions.

Standard values of  $R_{COMP} = 16\text{k}\Omega$  and  $C_{COMP} = 2.7\text{nF}$  works for the majority of the applications.

**Table 4. Recommended Compensation Network Values at High and Low Frequency**

FREQUENCY	L (μH)	V <sub>OUT</sub> (V)	V <sub>IN</sub> ± 20% (V)	R <sub>COMP</sub> (kΩ)	C <sub>COMP</sub>
High (1.2MHz)	3.3	15	5	100	820pF
			3.3	91	1.2nF
		12	5	68	820pF
			3.3	68	1.2nF
		9	5	39	820pF
			3.3	39	1.2nF
Low (650kHz)	6.8	15	5	51	1.5nF
			3.3	47	2.7nF
		12	5	33	1.5nF
			3.3	33	2.7nF
		9	5	18	1.5nF
			3.3	18	2.7nF

## APPLICATION INFORMATION (continued)

### Input Capacitor Selection

For optimal performance, low ESR ceramic capacitors are recommended for effective input voltage filtering. The SGM6627Q's analog input (IN) requires a 1 $\mu$ F bypass capacitor between IN and GND positioned as close to the IC as practical. Most applications benefit from two parallel 10 $\mu$ F ceramic input capacitors (or a single 22 $\mu$ F ceramic capacitor), with larger values enhancing filtering effect.

### Output Capacitor Selection

For optimal output voltage regulation, low ESR ceramic capacitors are recommended. A total output capacitance of 40 $\mu$ F (achieved via 4  $\times$  10 $\mu$ F or 2  $\times$  22 $\mu$ F configurations) typically satisfies typical application requirements. Increased capacitance values may enhance transient performance. The DC bias derating effects of the ceramic capacitors should be considered when selecting capacitors. Final component validation remains mandatory to verify compatibility under target operating conditions

To calculate the output voltage ripple, use Equation 10.

$$\Delta V_C = \frac{V_{OUT} - V_{IN}}{V_{OUT} \times f_s} \times \frac{I_{OUT}}{C_{OUT}}$$

$$\Delta V_{C\_ESR} = I_{L\_PEAK} \times R_{C\_ESR} \quad (10)$$

where,  $\Delta V_C$  is the output voltage ripple dependent on output capacitance, output current, and switching frequency.  $\Delta V_{C\_ESR}$  is the output voltage ripple due to output capacitors ESR (equivalent series resistance).  $I_{SW\_PEAK}$  is the inductor peak switch current in the application.  $R_{C\_ESR}$  is the output capacitors equivalent series resistance (ESR).  $\Delta V_{C\_ESR}$  can be neglected in many cases because ceramic capacitors provide low ESR.

### Layout Guidelines

For most switching power supplies, especially with high frequency and high current, a good layout is required to prevent EMI failure and device damage as well as good stability of the device.

- Use wide and short traces for main power traces.
- Place the input capacitor to the IN and GND pins as close as possible. If possible, choose high capacitance value for  $C_{IN}$  for a stable input.
- Since the SW pin carries high current with fast rising and falling edges, all connections to the SW pin should be kept as short and wide as possible.
- The output capacitor ( $C_{OUT}$ ) should be placed close to  $V_{OUT}$ . It is also beneficial to have the ground of  $C_{OUT}$  close to the GND pin since there is large ground return current flowing between them.
- Sensitive signals like FB and COMP must be placed away from SW trace to prevent noise coupling through parasitic capacitance. Components should be positioned in close proximity to the corresponding pins to cut down on parasitic inductance and capacitance.

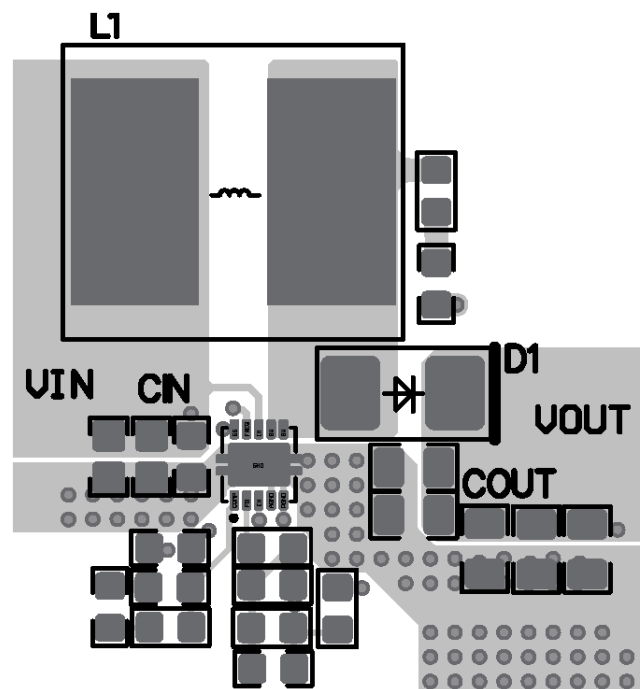

Figure 4. PCB Layout

**REVISION HISTORY**

NOTE: Page numbers for previous revisions may differ from page numbers in the current version.

<b>FEBRUARY 2026 – REV.A to REV.A.1</b>	<b>Page</b>
Updated the test condition of Load Regulation in ELECTRICAL CHARACTERISTICS section .....	4
Updated details in TYPICAL PERFORMANCE CHARACTERISTICS .....	5, 6

---

<b>Changes from Original to REV.A (NOVEMBER 2025)</b>	<b>Page</b>
Changed from product preview to production data .....	All

---

PACKAGE OUTLINE DIMENSIONS

TDFN-3x3-10BL

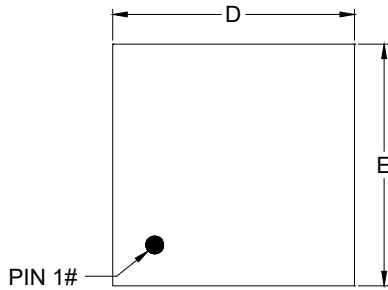

TOP VIEW

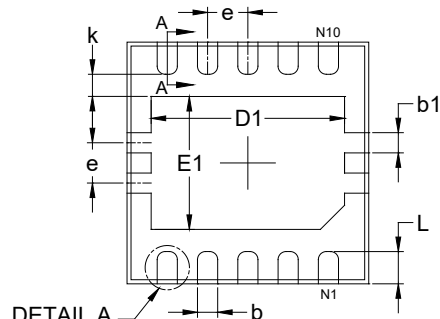

BOTTOM VIEW

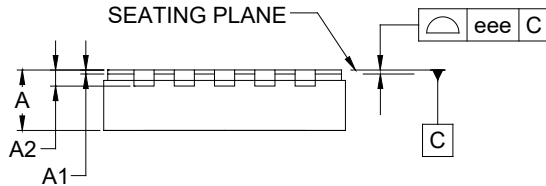

SIDE VIEW

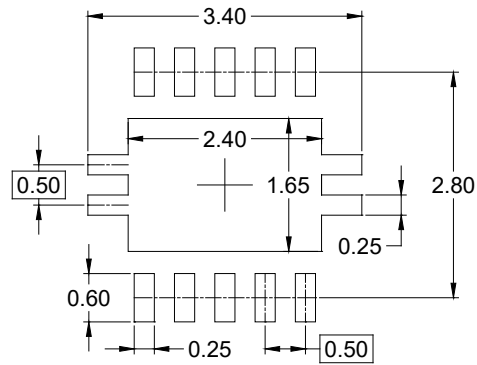

RECOMMENDED LAND PATTERN (Unit: mm)

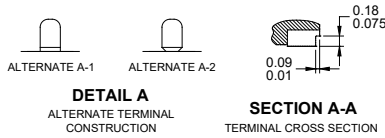

DETAIL A  
ALTERNATE TERMINAL  
CONSTRUCTION

SECTION A-A  
TERMINAL CROSS SECTION

Symbol	Dimensions In Millimeters		
	MIN	NOM	MAX
A	0.700	-	0.800
A1	0.000	-	0.050
A2	0.203 REF		
b	0.200	-	0.300
b1	0.250 REF		
D	2.900	-	3.100
D1	2.300	-	2.500
E	2.900	-	3.100
E1	1.550	-	1.750
e	0.500 BSC		
k	0.275 REF		
L	0.300	-	0.500
eee	0.080		

NOTE: This drawing is subject to change without notice.

TAPE AND REEL INFORMATION

REEL DIMENSIONS

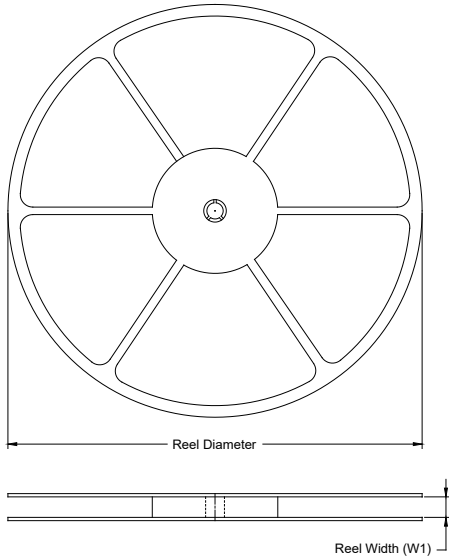

TAPE DIMENSIONS

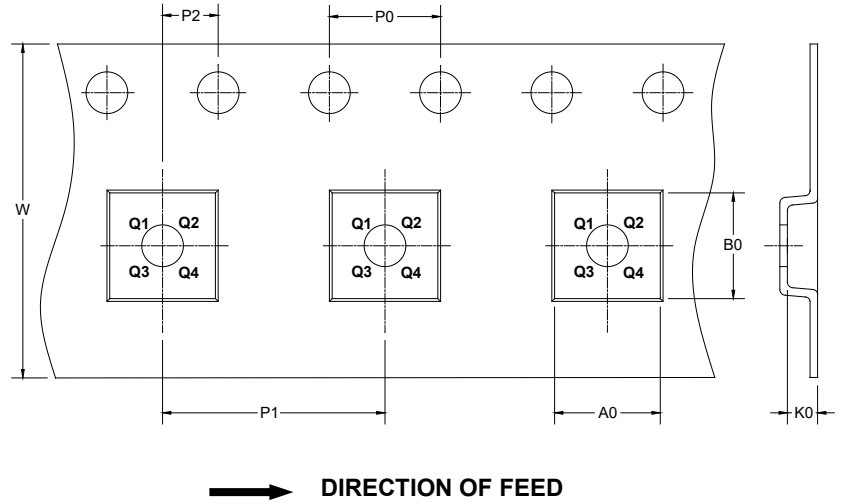

NOTE: The picture is only for reference. Please make the object as the standard.

KEY PARAMETER LIST OF TAPE AND REEL

Package Type	Reel Diameter	Reel Width W1 (mm)	A0 (mm)	B0 (mm)	K0 (mm)	P0 (mm)	P1 (mm)	P2 (mm)	W (mm)	Pin1 Quadrant
TDFN-3x3-10BL	13"	12.4	3.35	3.35	1.13	4.0	8.0	2.0	12.0	Q2

DD0001

# PACKAGE INFORMATION

## CARTON BOX DIMENSIONS

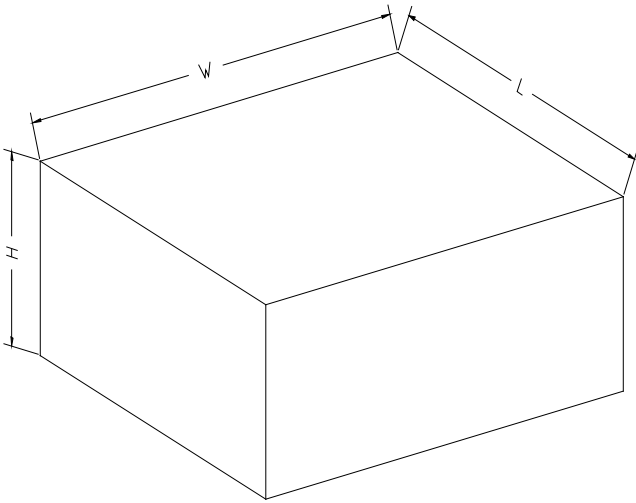

NOTE: The picture is only for reference. Please make the object as the standard.

## KEY PARAMETER LIST OF CARTON BOX

Reel Type	Length (mm)	Width (mm)	Height (mm)	Pizza/Carton
13"	386	280	370	5

DD0002