



SGM840

-4V to 80V, Bidirectional, Ultra-Precision Current-Sense Amplifier with High PWM Rejection

GENERAL DESCRIPTION

The SGM840 device is a bidirectional, fixed gain, voltage-output, current-sense amplifier which features high PWM rejection and wide common-mode voltage range from -4V to 80V.

The high PWM rejection suppresses large common-mode transients ($\Delta V/\Delta t$) on the output signal, which is particularly relevant for applications utilizing pulse width modulation (PWM), such as motor driver and solenoid control systems. The negative common-mode voltage capability allows the device to function even when the voltage is below ground, which is useful in typical applications like the flyback period of a solenoid.

These characteristics make accurate current measurement without large transients and related recovery disturbances on the output voltage.

The device is powered from a single 2.7V to 5.5V supply, and draws 1mA (TYP) supply current. There are three fixed gain options: 20V/V, 50V/V and 100V/V. The low offset in the zero-drift architecture enables highly accurate current sensing, even with very small voltage drops across the shunt as low as 10mV full-scale.

The SGM840 is available in Green SOIC-8, TSSOP-8 and MSOP-8 packages. It operates in the temperature range of -40°C to +125°C.

FEATURES

- **Functional Safety-Capable**
 - ♦ Documentation Available to Aid Functional Safety System Design
- **High PWM Rejection**
- **Excellent CMRR:**
 - ♦ 130dB (TYP) DC CMRR
 - ♦ 80dB (TYP) AC CMRR at 50kHz
- **Wide Common-Mode Range: -4V to 80V**
- **Gain Error:**
 - ♦ +25°C: $\pm 0.35\%$ (MAX)
 - ♦ -40°C to +125°C: $\pm 2\%$ (MAX)
- **Offset:**
 - ♦ +25°C: $\pm 90\mu\text{V}$ (MAX) of SGM840A/B/C
 - ♦ -40°C to +125°C: $\pm 230\mu\text{V}$ (MAX) of SGM840A
 - ♦ -40°C to +125°C: $\pm 180\mu\text{V}$ (MAX) of SGM840B/C
- **Available Gains:**
 - ♦ SGM840A: 20V/V
 - ♦ SGM840B: 50V/V
 - ♦ SGM840C: 100V/V
- **Available in Green SOIC-8, TSSOP-8 and MSOP-8 Packages**

APPLICATIONS

Motor Controls
Solenoid and Valve Controls
Power Management
Actuator Controls
Pressure Regulators
Telecom Equipment

TYPICAL APPLICATION

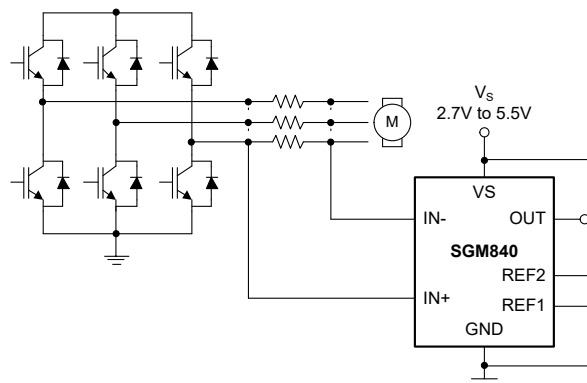

Figure 1. Typical Application Circuit

-4V to 80V, Bidirectional, Ultra-Precision SGM840 Current-Sense Amplifier with High PWM Rejection

PACKAGE/ORDERING INFORMATION

| MODEL | PACKAGE DESCRIPTION | SPECIFIED TEMPERATURE RANGE | ORDERING NUMBER | PACKAGE MARKING | PACKING OPTION |
|----------------------------|---------------------|-----------------------------|-----------------|--------------------------|---------------------|
| SGM840A (Gain = 20V/V) | SOIC-8 | -40°C to +125°C | SGM840AXS8G/TR | SGM 840AXS8 XXXXX | Tape and Reel, 4000 |
| | TSSOP-8 | -40°C to +125°C | SGM840AXTS8G/TR | SGM840A XTS8 XXXXX | Tape and Reel, 4000 |
| | MSOP-8 | -40°C to +125°C | SGM840AXMS8G/TR | SGM840A XMS8 XXXXX | Tape and Reel, 4000 |
| SGM840B (Gain = 50V/V) | SOIC-8 | -40°C to +125°C | SGM840BXS8G/TR | SGM 840BXS8 XXXXX | Tape and Reel, 4000 |
| | TSSOP-8 | -40°C to +125°C | SGM840BXTS8G/TR | SGM840B XTS8 XXXXX | Tape and Reel, 4000 |
| | MSOP-8 | -40°C to +125°C | SGM840BXMS8G/TR | SGM840B XMS8 XXXXX | Tape and Reel, 4000 |
| SGM840C (Gain = 100V/V) | SOIC-8 | -40°C to +125°C | SGM840CXS8G/TR | SGM 840CXS8 XXXXX | Tape and Reel, 4000 |
| | TSSOP-8 | -40°C to +125°C | SGM840CXTS8G/TR | SGM840C XTS8 XXXXX | Tape and Reel, 4000 |
| | MSOP-8 | -40°C to +125°C | SGM840CXMS8G/TR | SGM840C XMS8 XXXXX | Tape and Reel, 4000 |

MARKING INFORMATION

NOTE: XXXXX = Date Code, Trace Code and Vendor Code.

XXXXX

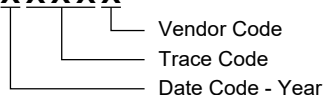

Green (RoHS & HSF): SG Micro Corp defines "Green" to mean Pb-Free (RoHS compatible) and free of halogen substances. If you have additional comments or questions, please contact your SGMICRO representative directly.

ABSOLUTE MAXIMUM RATINGS

| | |
|--|----------------------------|
| Supply Voltage, V_S | 6V |
| Analog Inputs, V_{IN+} , V_{IN-} | |
| Differential $V_{IN+} - V_{IN-}^{(1)}$ | -60V to 60V |
| Common-Mode | -6V to 85V |
| REF1, REF2, NC Inputs..... | GND - 0.3V to $V_S + 0.3V$ |
| Output..... | GND - 0.3V to $V_S + 0.3V$ |
| Package Thermal Resistance | |
| SOIC-8, θ_{JA} | 114.3°C/W |
| SOIC-8, θ_{JB} | 63.9°C/W |
| SOIC-8, θ_{JC} | 54.5°C/W |
| TSSOP-8, θ_{JA} | 149.8°C/W |
| TSSOP-8, θ_{JB} | 100.2°C/W |
| TSSOP-8, θ_{JC} | 51.2°C/W |
| MSOP-8, θ_{JA} | 131.2°C/W |
| MSOP-8, θ_{JB} | 77.8°C/W |
| MSOP-8, θ_{JC} | 46.3°C/W |
| Junction Temperature..... | +150°C |
| Storage Temperature Range | -65°C to +150°C |
| Lead Temperature (Soldering, 10s)..... | +260°C |
| ESD Susceptibility ^{(2) (3)} | |
| HBM..... | ±8000V |
| CDM | ±2000V |

NOTES:

1. The device will remain undamaged for at least 168 hours.
2. For human body model (HBM), all pins comply with ANSI/ESDA/JEDEC JS-001 specifications.
3. For charged device model (CDM), all pins comply with ANSI/ESDA/JEDEC JS-002 specifications.

RECOMMENDED OPERATING CONDITIONS

| | |
|---|-----------------|
| Input Common-Mode Voltage, V_{CM} | -4V to 80V |
| Supply Voltage Range, V_S | 2.7V to 5.5V |
| Operating Ambient Temperature Range | -40°C to +125°C |
| Operating Junction Temperature Range..... | -40°C to +125°C |

OVERSTRESS CAUTION

Stresses beyond those listed in Absolute Maximum Ratings may cause permanent damage to the device. Exposure to absolute maximum rating conditions for extended periods may affect reliability. Functional operation of the device at any conditions beyond those indicated in the Recommended Operating Conditions section is not implied.

ESD SENSITIVITY CAUTION

This integrated circuit can be damaged if ESD protections are not considered carefully. SGMICRO recommends that all integrated circuits be handled with appropriate precautions. Failure to observe proper handling and installation procedures can cause damage. ESD damage can range from subtle performance degradation to complete device failure. Precision integrated circuits may be more susceptible to damage because even small parametric changes could cause the device not to meet the published specifications.

DISCLAIMER

SG Micro Corp reserves the right to make any change in circuit design, or specifications without prior notice.

PIN CONFIGURATIONS

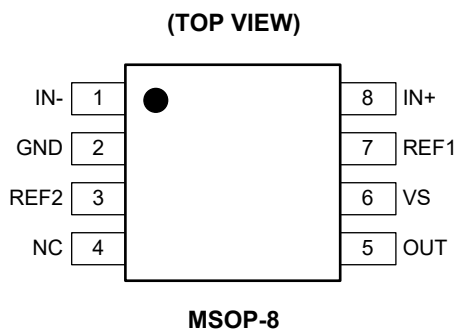
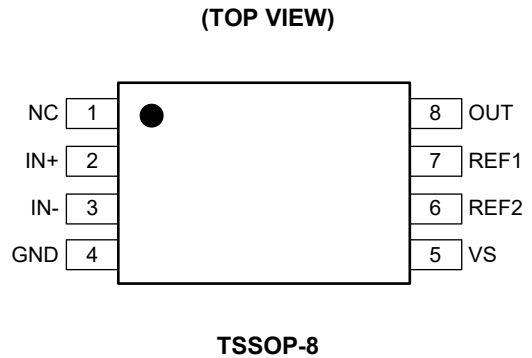
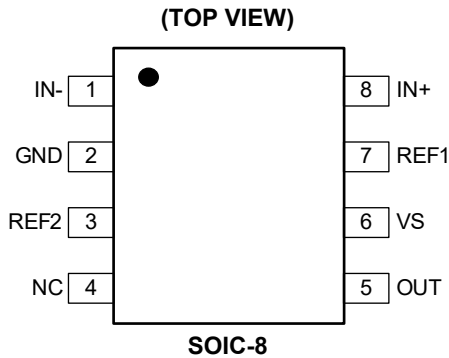

PIN DESCRIPTION

| PIN | | NAME | TYPE | FUNCTION |
|-------------------|---------|------|------|---|
| SOIC-8/ MSOP-8 | TSSOP-8 | | | |
| 1 | 3 | IN- | A/I | Connect it to load side of shunt resistor. |
| 2 | 4 | GND | G | Ground. |
| 3 | 6 | REF2 | A/I | Voltage Reference 2. Connect it to any voltage source between GND and V_S . |
| 4 | 1 | NC | — | Connect it to GND or leave it floating. |
| 5 | 8 | OUT | A/O | Output Voltage. |
| 6 | 5 | VS | P | 2.7V to 5.5V Power Supply. |
| 7 | 7 | REF1 | A/I | Voltage Reference 1. Connect it to any voltage source between GND and V_S . |
| 8 | 2 | IN+ | A/I | Connect it to supply side of shunt resistor. |

NOTE: I = input, O = output, A = analog, P = power, G = ground.

-4V to 80V, Bidirectional, Ultra-Precision SGM840 Current-Sense Amplifier with High PWM Rejection

ELECTRICAL CHARACTERISTICS

($V_S = 5V$, $V_{SENSE} = V_{IN+} - V_{IN-}$, $V_{CM} = 12V$, $V_{REF1} = V_{REF2} = V_S/2$ and $T_A = -40^\circ C$ to $+125^\circ C$, typical values are measured at $T_A = +25^\circ C$, unless otherwise noted.)

| PARAMETER | SYMBOL | CONDITIONS | MIN | TYP | MAX | UNITS |
|--|----------|--|-----|---------------|----------------|----------------|
| Input | | | | | | |
| Input Common-Mode Voltage | V_{CM} | $V_{IN+} = -4V$ to $80V$, $V_{SENSE} = 0mV$ | -4 | | 80 | V |
| Common-Mode Rejection Ratio | CMRR | $V_{IN+} = -4V$ to $80V$, $V_{SENSE} = 0mV$ | 120 | 130 | | dB |
| | | $f = 50kHz$ | | 80 | | |
| Offset Voltage, Input-Referred | V_{OS} | $V_{SENSE} = 0mV$, $T_A = +25^\circ C$ | | ± 5 | ± 90 | μV |
| | | $V_{SENSE} = 0mV$, $T_A = -40^\circ C$ to $+125^\circ C$, SGM840A | | | ± 230 | |
| | | $V_{SENSE} = 0mV$, $T_A = -40^\circ C$ to $+125^\circ C$, SGM840B/C | | | ± 180 | |
| Power Supply Rejection Ratio | PSRR | $V_S = 2.7V$ to $5.5V$, $V_{SENSE} = 0mV$ | | ± 1 | ± 20 | $\mu V/V$ |
| Input Bias Current | I_B | I_{B+} , I_{B-} , $V_{SENSE} = 0mV$ | | 0.05 | | μA |
| Reference Input Range | | | 0 | | V_S | V |
| Output | | | | | | |
| Gain | G | SGM840A | | 20 | | V/V |
| | | SGM840B | | 50 | | |
| | | SGM840C | | 100 | | |
| Gain Error | | $GND + 50mV \leq V_{OUT} \leq V_S - 200mV$, $T_A = +25^\circ C$ | | ± 0.05 | ± 0.35 | % |
| | | $T_A = -40^\circ C$ to $+125^\circ C$ | | | ± 2 | |
| Nonlinearity Error | | $GND + 10mV \leq V_{OUT} \leq V_S - 200mV$ | | ± 0.02 | | % |
| Reference Divider Accuracy | | $V_{OUT} = (V_{REF1} - V_{REF2}) /2$ at $V_{SENSE} = 0mV$ | | ± 0.02 | ± 0.45 | % |
| Reference Voltage Rejection Ratio (Input-Referred) | RVRR | SGM840A | | 45 | | $\mu V/V$ |
| | | SGM840B | | 25 | | |
| | | SGM840C | | 15 | | |
| Maximum Capacitive Load | | No sustained oscillation | | 1 | | nF |
| Voltage Output | | | | | | |
| Swing to VS Power Supply Rail | | $R_L = 10k\Omega$ to GND | | $V_S - 0.02$ | $V_S - 0.05$ | V |
| Swing to GND | | $R_L = 10k\Omega$ to GND, $V_{SENSE} = 0mV$, $V_{REF1} = V_{REF2} = 0V$ | | $V_{GND} + 3$ | $V_{GND} + 10$ | mV |
| Frequency Response | | | | | | |
| Bandwidth | BW | All gains, -3dB bandwidth | | 400 | | kHz |
| | | All gains, 1% THD+N | | 100 | | |
| Settling Time | | Output settles to 0.5% of final value | | 6 | | μs |
| Slew Rate | SR | | | 2.5 | | V/ μs |
| Noise (Input-Referred) | | | | | | |
| Voltage Noise Density | | | | 100 | | nV/\sqrt{Hz} |
| Power Supply | | | | | | |
| Operating Voltage Range | V_S | | 2.7 | | 5.5 | V |
| Quiescent Current | I_Q | $V_{SENSE} = 0mV$, $T_A = +25^\circ C$ | | 1.0 | 1.5 | mA |
| | | vs. temperature, $T_A = -40^\circ C$ to $+125^\circ C$ | | | 1.7 | |

TYPICAL PERFORMANCE CHARACTERISTICS

$V_S = 5V$, $V_{CM} = 12V$, $V_{REF1} = V_{REF2} = V_S/2$ and $T_A = +25^\circ C$, unless otherwise noted.

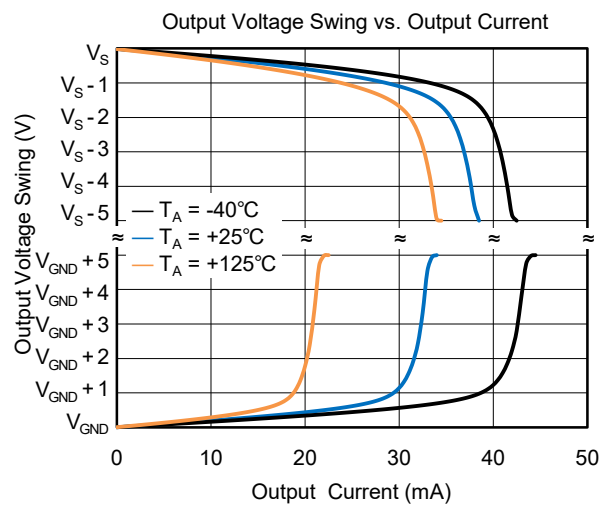
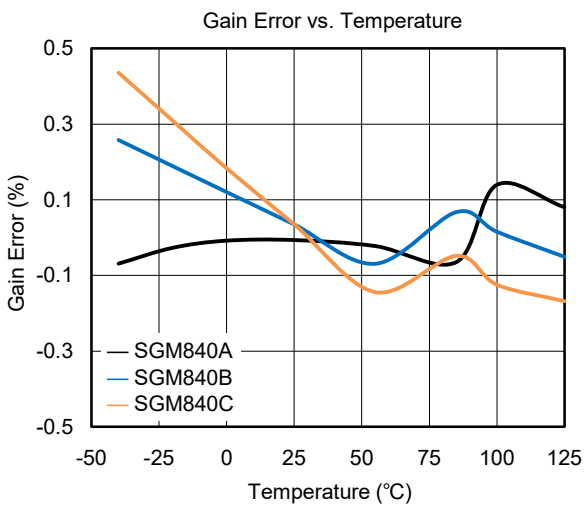
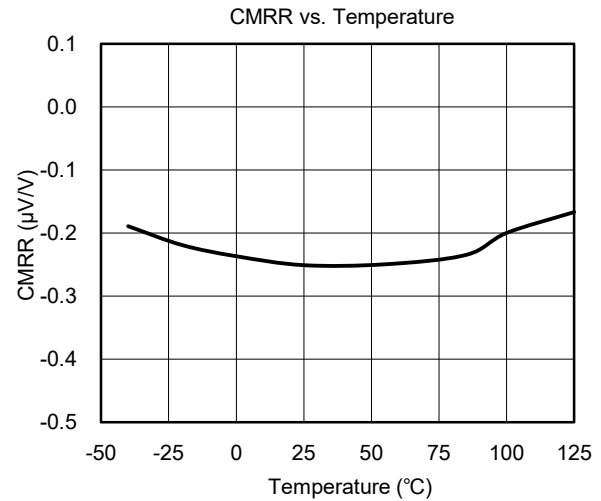
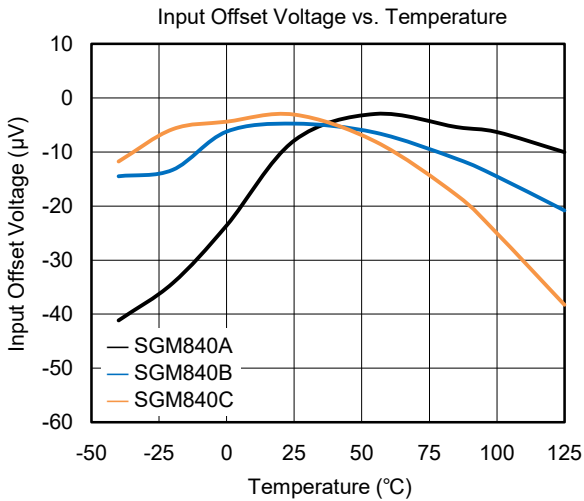
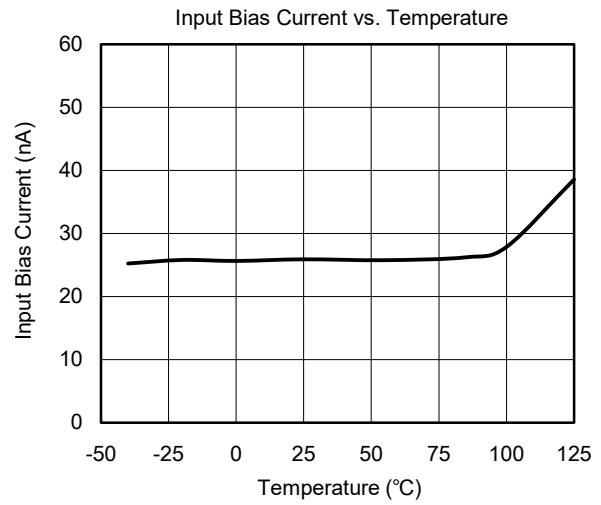
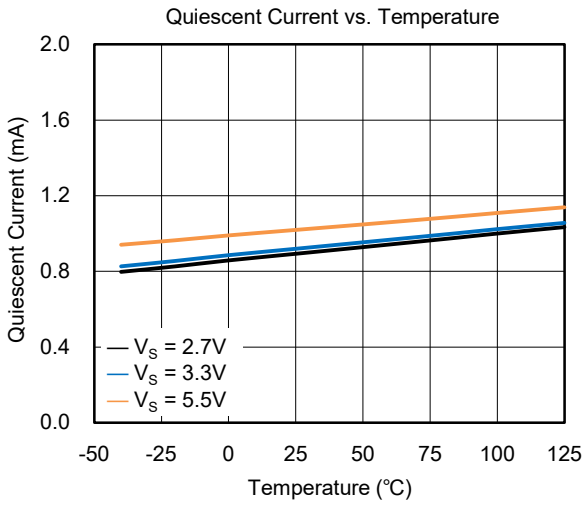

-4V to 80V, Bidirectional, Ultra-Precision SGM840 Current-Sense Amplifier with High PWM Rejection

TYPICAL PERFORMANCE CHARACTERISTICS (continued)

$V_S = 5V$, $V_{CM} = 12V$, $V_{REF1} = V_{REF2} = V_S/2$ and $T_A = +25^\circ C$, unless otherwise noted.

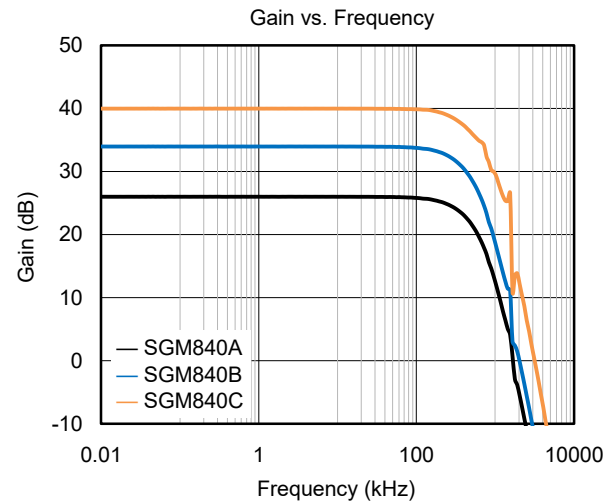
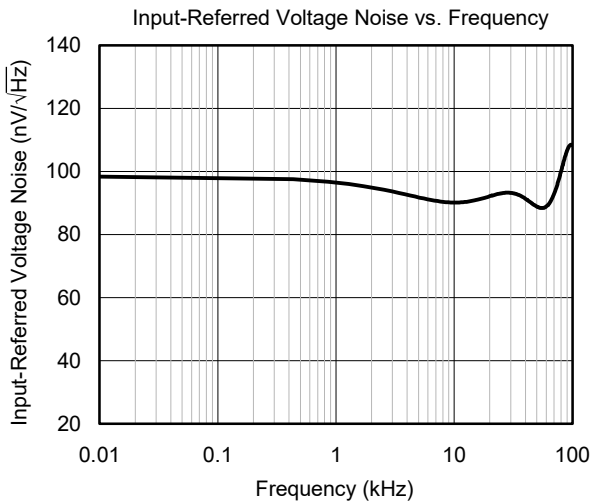
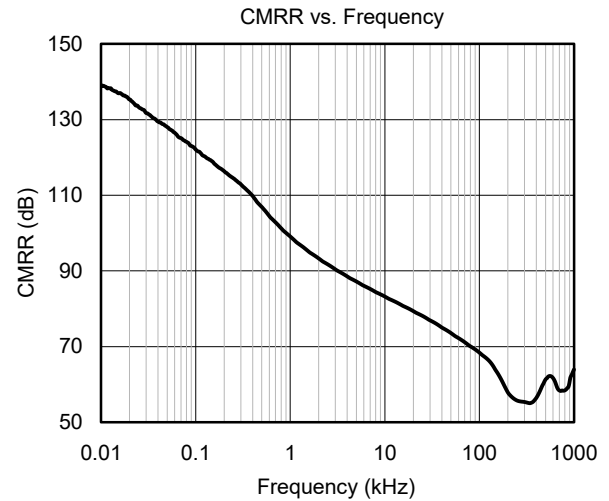
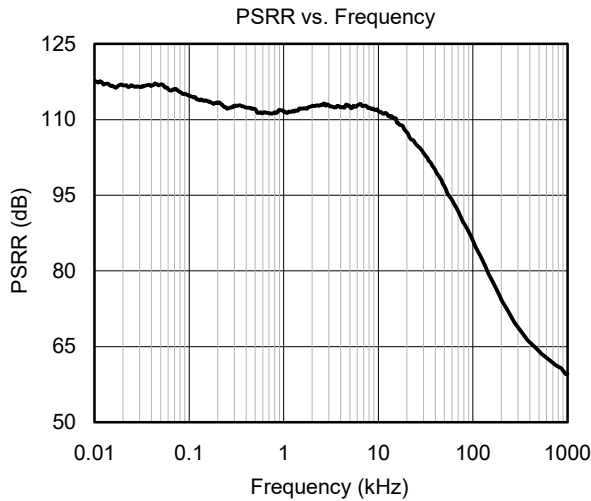
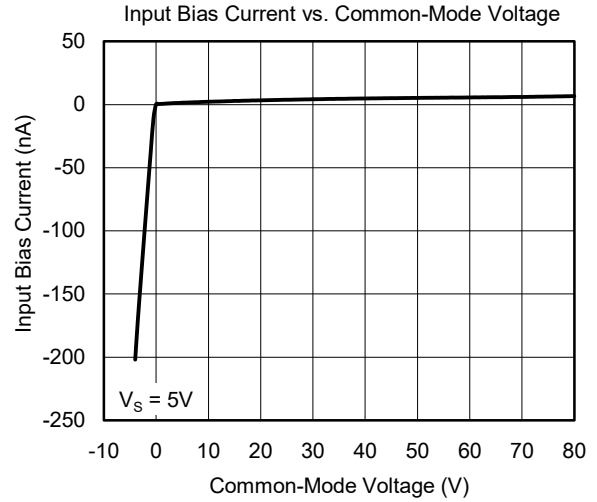
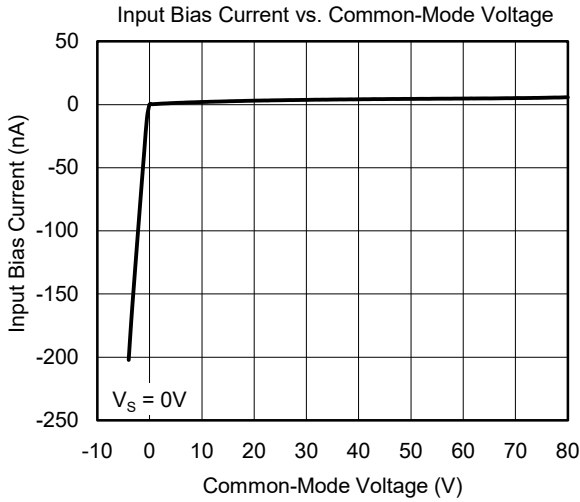

-4V to 80V, Bidirectional, Ultra-Precision SGM840 Current-Sense Amplifier with High PWM Rejection

TYPICAL PERFORMANCE CHARACTERISTICS (continued)

$V_S = 5V$, $V_{CM} = 12V$, $V_{REF1} = V_{REF2} = V_S/2$ and $T_A = +25^\circ C$, unless otherwise noted.

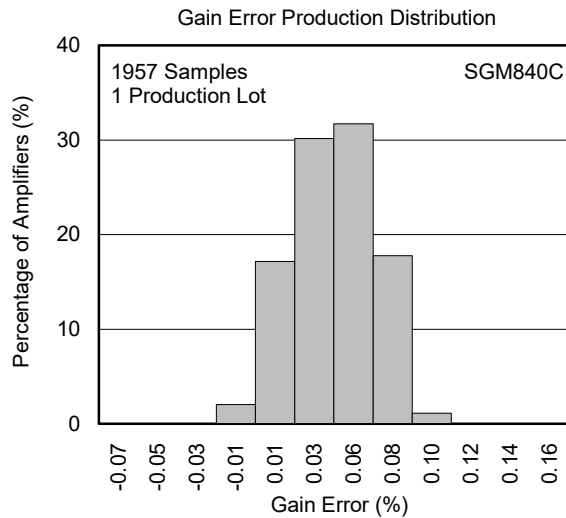
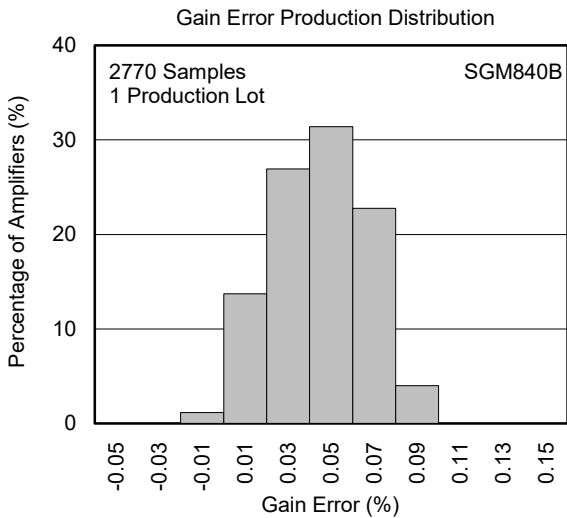
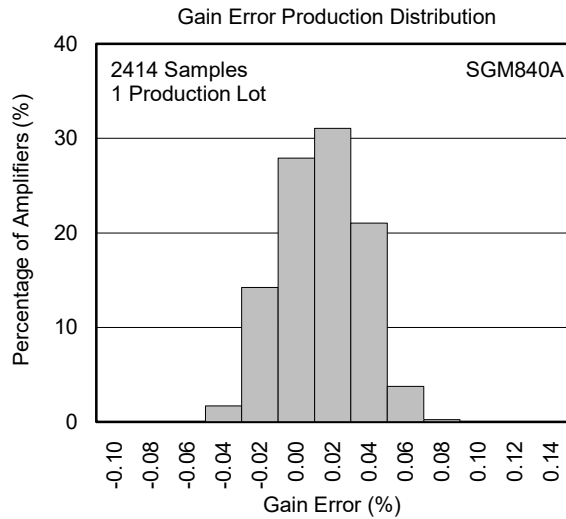
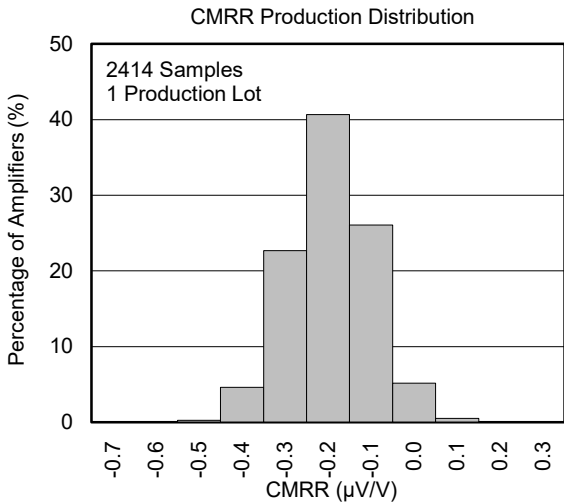
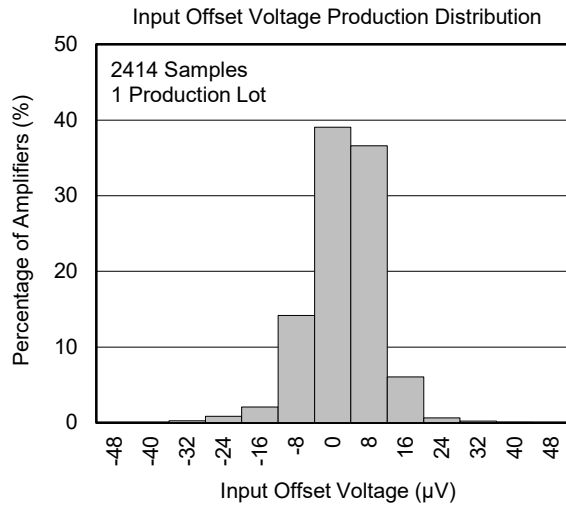
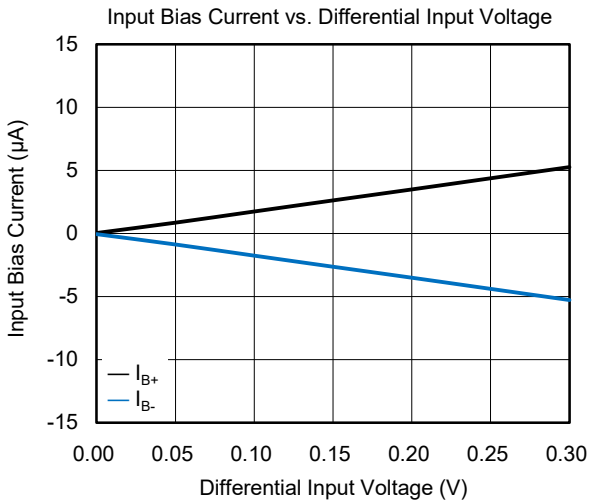

SGM840 -4V to 80V, Bidirectional, Ultra-Precision Current-Sense Amplifier with High PWM Rejection

TYPICAL PERFORMANCE CHARACTERISTICS (continued)

$V_S = 5V$, $V_{CM} = 12V$, $V_{REF1} = V_{REF2} = V_S/2$ and $T_A = +25^\circ C$, unless otherwise noted.

0.1Hz to 10Hz Voltage Noise

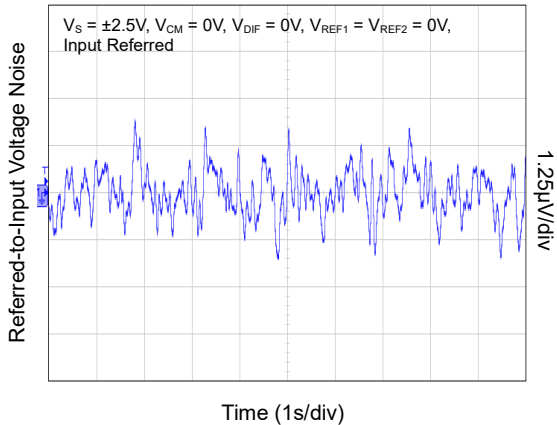

Step Response

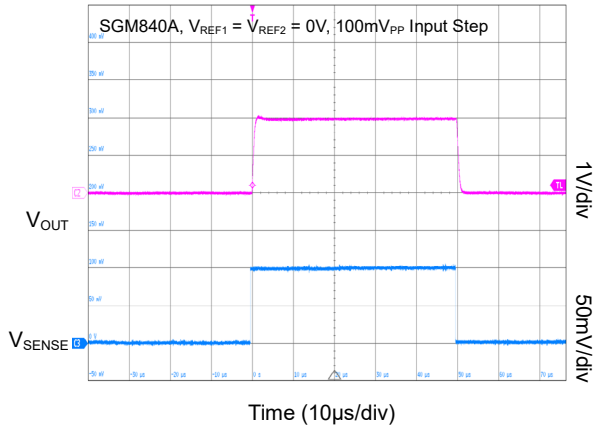

Common-Mode Voltage Transient Response

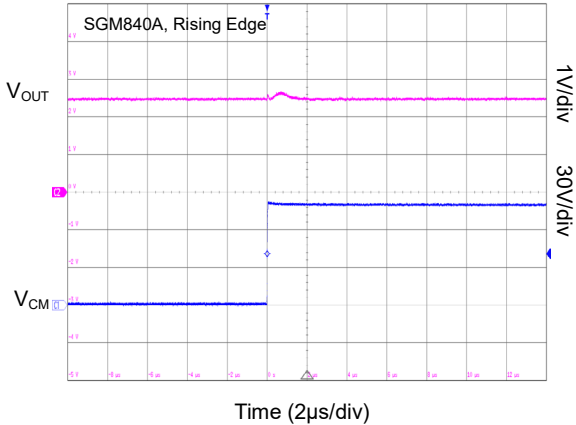

Common-Mode Voltage Transient Response

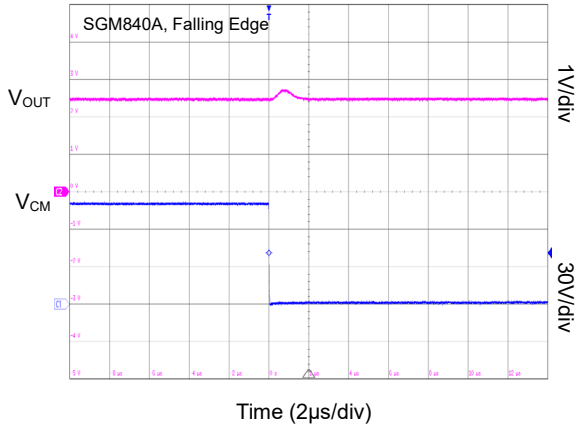

Startup Response

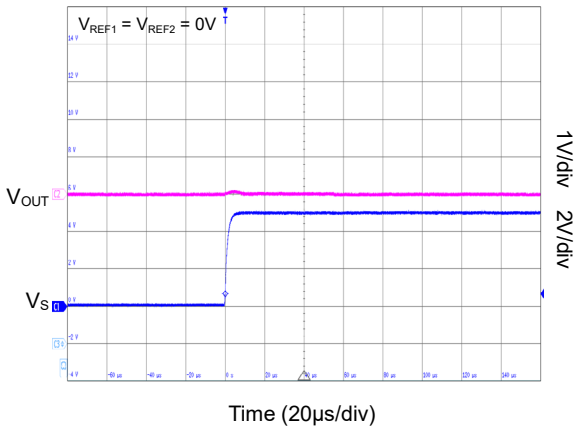

FUNCTIONAL BLOCK DIAGRAM

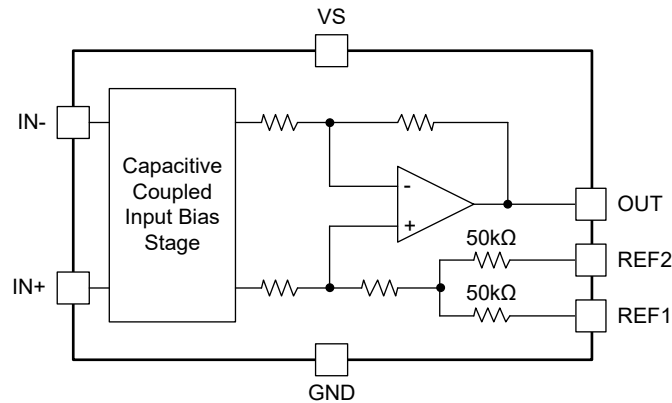

Figure 2. Block Diagram

DETAILED DESCRIPTION

Overview

The SGM840 is a bidirectional analog voltage output current-sense amplifier with a wide common-mode range, high accuracy, zero-drift topology, and high common-mode rejection. High common-mode rejection can suppress the effect of fast common-mode transients on the output. Multiple gain versions can be used to optimize the required full-scale output voltage according to the expected target current range in the application.

Feature Description

Precision Current Measurement

The SGM840 uses the zero-drift input architecture which provides the low offset voltage and low offset drift. The offset voltage of SGM840A is less than $\pm 180\mu\text{V}$ from -40°C to $+125^\circ\text{C}$, and the SGM840B/C is less than $\pm 230\mu\text{V}$ from -40°C to $+125^\circ\text{C}$. The internal gain resistor has excellent temperature stability, ensuring that the gain error remains within $\pm 2\%$. All of these features improve the accuracy, especially at smaller current-sense voltage, and allow for lower-value shunt resistor.

Large Input Common-Mode Voltages

The SGM840 uses a capacitive feedback amplifier on the input front end which makes the input common-mode voltage range no longer restricted by the power supply voltage (V_S). DC common-mode voltages are blocked from downstream circuits, resulting in very high common-mode rejection. The SGM840 can support wide common-mode voltages

from -4V to 80V . This allows for the SGM840 to be used for both low-side and high-side current-sensing applications.

Low Input Bias Current

The SGM840 has low input bias current which draws a $0.05\mu\text{A}$ (TYP) at a common-mode voltage up to 80V . This feature achieves precision current sensing in applications where lower current leakage is required.

High Input-Signal Bandwidth

The SGM840 has 400kHz (TYP) input signal bandwidth and $2.5\text{V}/\mu\text{s}$ slew rate which provide the rapid throughput and response needed to quickly detect and handle over-current events. Without higher bandwidth, the protection circuit has not fast response time and may cause damage to the monitored application or circuit.

Bidirectional Current Monitoring

The SGM840 can sense current flow through a sense resistor in both directions. The output voltage (V_{OUT}) can be calculated according to the formula below.

$$V_{\text{OUT}} = (I_{\text{SENSE}} \times R_{\text{SENSE}} \times G) + V_{\text{BIAS}} \quad (1)$$

where:

I_{SENSE} is the load current that flows through a sense resistor.

R_{SENSE} is the current-sense resistor.

G is the available gain option of the selected device.

V_{BIAS} is the biased voltage of output set by REF1 and REF2 pins.

DETAILED DESCRIPTION (continued)

High PWM Rejection

The SGM840 uses a capacitive coupled amplifier which has high PWM rejection. The high PWM rejection allows the output to recover quickly after a rapid input PWM common-mode transient. The settling time after PWM common-mode transient events is about 2µs typically. This feature makes it possible to support higher PWM frequencies and lower duty cycles in applications like motor, solenoid control and switching power supplies.

Low THD+Noise Output

Figure 3 displays the device's performance across different frequencies. The SGM840 has less harmonic distortion which is beneficial for use in the audio.

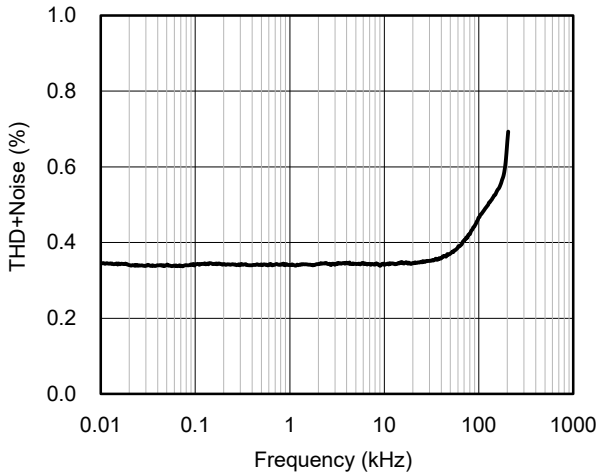

Figure 3. Performance over Frequency

Device Functional Modes

Adjusting the Output Midpoint with REFx Pins

Figure 4 shows a reference test circuit for the accuracy of the internal resistor divider. The SGM840 output can be configured to allow unidirectional or bidirectional operation.

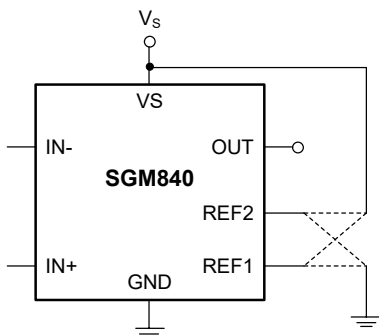

Figure 4. Test Circuit for Reference Divider Accuracy

Note that the input voltage of the REF1 pin or the REF2 pin must be between VS or GND.

The REF1 and REF2 are connected to the internal gain resistor divider network inside the chip. The output biased voltage can be set by connecting REF1 and REF2 to different voltage source such as VS, GND, or a low-impedance reference voltage.

Unidirectional Current Measurements with REFx Pins

Unidirectional operation allows the SGM840 to measure the current through a resistive shunt in a single direction. There is ground referenced output or VS referenced output. The following sections describe the two different configurations.

GND Referenced Output

Connect both reference pins of SGM840 together to GND. The current direction in this configuration is from IN+ to IN-.

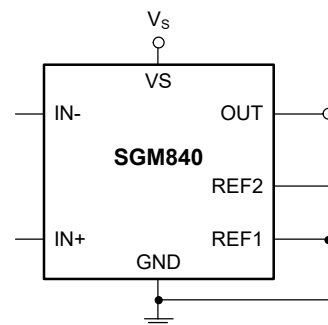

Figure 5. GND Referenced Output

VS Referenced Output

Connect both reference pins of SGM840 together to VS. The current direction is from IN- to IN+. This configuration is suitable for applications that require a stable power supply to the amplifier output and other control circuits before there is a current flowing through the current-sense resistor.

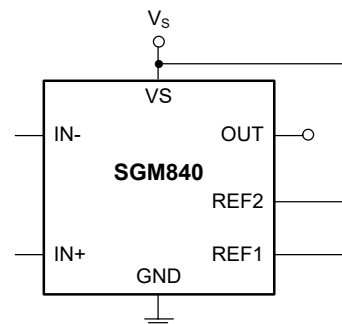

Figure 6. VS Referenced Output

DETAILED DESCRIPTION (continued)

Bidirectional Current Measurements with the Reference Pins

Bidirectional operation allows the SGM840 to measure the current through the resistor shunt in both directions. The common configuration is to set the reference input at half of the output full-scale which allows for an equal range in both directions. In asymmetrical bidirectional current sense application, the reference input can be set to others according to the application.

Setting Output to External Reference Voltage

Connect both reference pins together to an external reference voltage. The output biased voltage is equal to the reference voltage in this configuration. This is the most accurate method to bias the output to the reference voltage.

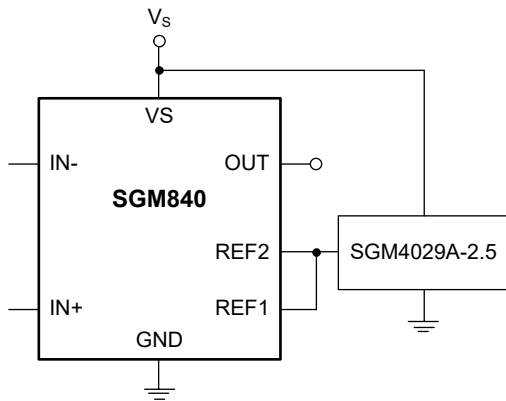

Figure 7. External Reference Output

Setting Output to a Half of Vs

Connect one reference pin to VS and the other reference pin to GND. The output biased voltage is equal to a half of Vs in this configuration. The output bias voltage keeps at a half if Vs varies.

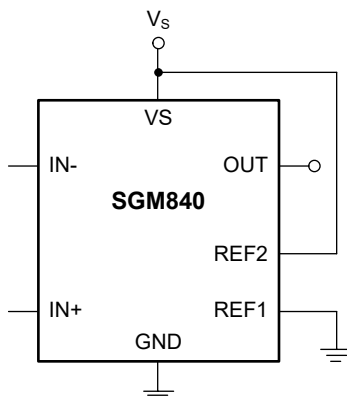

Figure 8. A Half of VS Output

Setting Output to a Half of External Reference

Connect one REF pin to an external reference and the other REF to the GND. The output biased voltage is equal to a half of external reference in this configuration. The output bias voltage keeps at a half of external reference if the external reference varies.

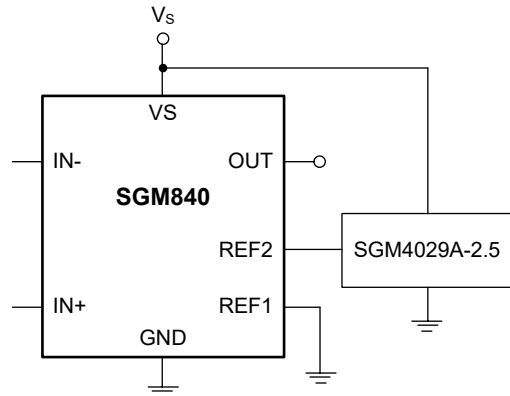

Figure 9. A Half of External Reference Output

Setting a Differential Output

As described above, the reference pins are usually configured to connect to supply, ground, or a low-impedance reference voltage. However, in some application, a differential output voltage is needed. Connecting the two reference pins together can get a differential output voltage between the reference and OUT pins. Figure 10 shows the configuration circuit.

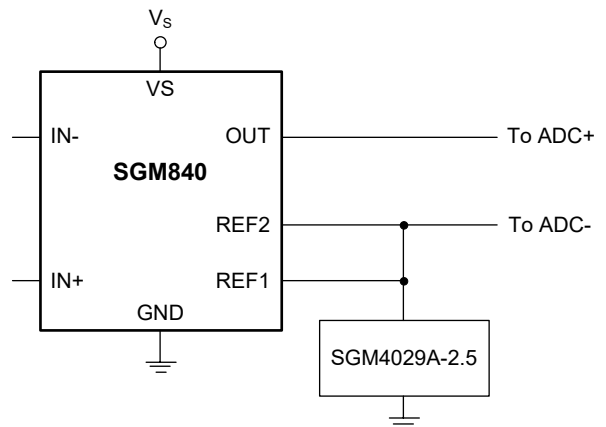

Figure 10. Reference Different Output

APPLICATION INFORMATION

The SGM840 can operate in unidirectional or bidirectional current-sensing operation by the different reference pins connection. In the in-line motor current sense applications, SGM840 is usually configured to bidirectional mode operation.

R_{SENSE} and Device Gain Selection

The proper resistance value selection is very critical to the current sensing system. Choose R_{SENSE} based on these criteria: the measured current range, the available gain device, the input range of the backend receiving circuit, and the measurement accuracy.

Within the range of the backend receiving circuit, the resistance of current-sensing resistor should be as large as possible. A larger current-sensing resistance develops a higher sensed voltage across the resistor. The higher the sensed voltage decreases, the smaller the error proportion caused by the input offset of the measured signal, and the higher the accuracy. However, higher resistance also leads to more power dissipation additionally, which makes the resistance drift and affects the precision of any measurement system due to the temperature coefficient. To limit the power loss, it is preferred to minimize the shunt resistance.

Still, the resistance of current-sensing resistor should not be too small. A smaller current-sensing resistance needs a higher amplifier gain to achieve the full-scale output voltage. A higher-gain amplifier has more error proportion caused by the input offset and noise, making it less suitable for precision designs.

Therefore, for the best performance, the selected current-sensing resistor should provide approximately the maximum input differential sense voltage with full-scale output voltage, while having lower power dissipation and higher accuracy. Note that the tolerance and temperature coefficient of the chosen resistors

directly affect the precision of any measurement system.

Packaging of the current-sensing resistor is also an important aspect to consider. Small package size is good for space savings and improved integration, but may have poor thermal performance. Larger package size has better heat dissipation, but can be costly.

Therefore, the choice of current-sensing resistor is based on the trade-off between measurement accuracy, power consumption and cost. Generally, sense resistors of 5mΩ to 100mΩ are available with 1% accuracy or better.

The SGM840 provides 20V/V, 50V/V and 100V/V gain as available options for use. Table 1 gives the different results from 20V/V, 50V/V and 100V/V gain. The higher gain allows a smaller current-sensing resistor resistance and achieves lower power dissipation.

Input Filtering

When measuring current in noisy environments, filters are required for accurate measurements. The SGM840 features low input bias current that makes it possible to add a filter at the input end without sacrificing the current-sense accuracy. The filter at the input position can attenuate differential noise before the input signal is amplified. Figure 11 shows the filter at the input pins.

The series resistance of filter results in additional gain error. The gain error introduced can be calculated by the Equation 2.

$$\text{Gain Error(\%)} = \left(1 - \frac{R_{\text{DIFF}}}{R_{\text{SENSE}} + 2 \times R_{\text{F}} + R_{\text{DIFF}}} \right) \times 100 \quad (2)$$

where:

R_{DIFF} is the differential input impedance about 55kΩ.

R_F is the added value of the series filter resistance.

Table 1. R_{SENSE} Selection and Power Dissipation ⁽¹⁾

| Parameter | Symbol | Equation | Results | | |
|--|--------------------|--|---------|---------|---------|
| | | | SGM840A | SGM840B | SGM840C |
| Gain | G | — | 20V/V | 50V/V | 100V/V |
| Ideal Maximum Differential Input Voltage | V _{DIFF} | V _{DIFF} = V _{OUT} /Gain | 125mV | 50mV | 25mV |
| Current-Sense Resistor Value | R _{SENSE} | R _{SENSE} = V _{DIFF} /I _{MAX} | 12.5mΩ | 5mΩ | 2.5mΩ |
| Current-Sense Resistor Power Dissipation | P _{RENSE} | R _{SENSE} × I _{MAX} ² | 1.25W | 0.5W | 0.25W |

NOTE: Full-scale current = 10A, and full-scale output voltage = 2.5V.

APPLICATION INFORMATION (continued)

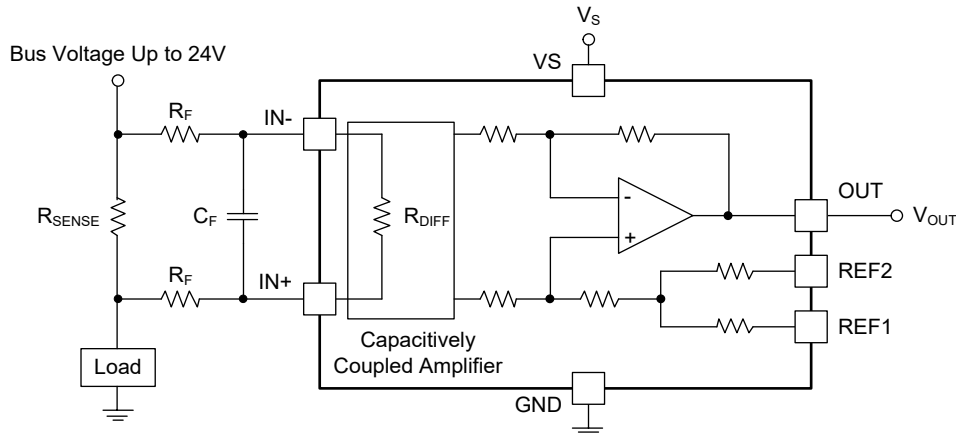

Figure 11. Filter at Input Pins

The high input impedance and low bias current of the SGM840 make the design of input filters easy and flexible without impacting the accuracy of current measurement. External series resistance adds to the measurement error, so limit the value of these series resistors to 22Ω or less. For example, set $R_F = 22\Omega$ and $C_F = 2.2nF$ to achieve a low-pass filter corner frequency of 1.64MHz without severely impacting the current-sensing bandwidth or precision. Table 2 illustrates the gain error introduced by R_F where R_{SENSE} has been neglected.

Table 2. Gain Error Introduced by the External Filter Resistance at Input Pins

| External Filter Resistance R_F (Ω) | Gain Error (%) |
|--------------------------------------|----------------|
| 4.7 | 0.017 |
| 10 | 0.036 |
| 22 | 0.08 |

Typical Applications

The SGM840 features the following advantages in applications:

1. Wide common-mode range and excellent CMRR allows for in-line current sense.
2. Ultra-low offset and drift make calibration unnecessary
3. Ultra-low input bias current is benefit for accuracy of small current measurement and input filtering.
4. The high PWM rejection allows the output to recover quickly after a rapid input PWM common-mode transient.
5. The power supply range can be interfaced and compatible with most microprocessors. The power supply of most microprocessors is 3.3V or 5V.

In-Line Motor Current Measurement

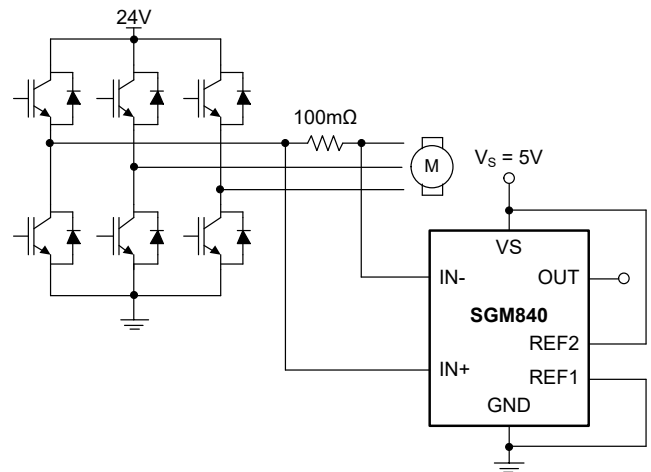

Figure 12. In-Line Motor Current Measurement

Design Requirements

In-line current sensing is necessary in motor control applications. However, the presence of rapid and large common-mode voltage transients of source voltage cause the in-line current measurement to inaccurate, which must be overcome.

The SGM840 features good common-mode rejection capability, high precision, up to 400kHz bandwidth and high common-mode specifications which fit this application well.

Detailed Design Procedure

For this application, SGM840 is used to measure the phase current of a 24V, 4000RPM motor.

Select the device with a gain of 20V/V and is powered by a 5V power supply.

APPLICATION INFORMATION (continued)

Configure the device for bidirectional current measurements. Output biased voltage is set to half of V_S by connecting REF1 to GND and REF2 to V_S to split the supply. Surely, output biased voltage can be tied together and connected to an external reference voltage.

Select a 100mΩ resistor to keep the analog input within the device limits.

Application Curve

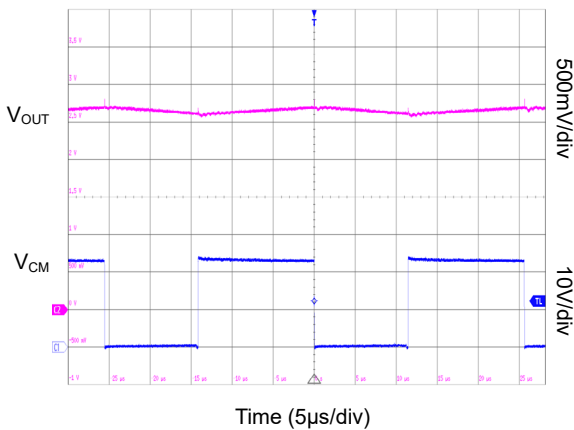

Figure 13. In-Line Motor Current-Sense Input and Output Signals

Solenoid Drive Current Measurement

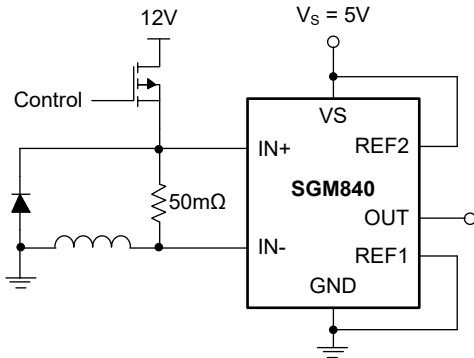

Figure 14. Solenoid Drive Current Measurement

Design Requirements

In solenoid drive current sensing application, the high PWM rejection of current-sensing amplifier is also needed. The SGM840 is a choice for these kind of applications.

Detailed Design Procedure

For this application, the SGM840 is used to measure the current of 12V, 0.5A water value.

Select the device with a gain of 100V/V and use a 5V power supply.

Configure the device for bidirectional current measurements. Output biased voltage is set to half of V_S by connecting REF1 to GND and REF2 to V_S to split the supply. Surely, output biased voltage can be tied together and connected to an external reference voltage.

Select a 50mΩ resistor to keep the analog input within the device limits.

Application Curve

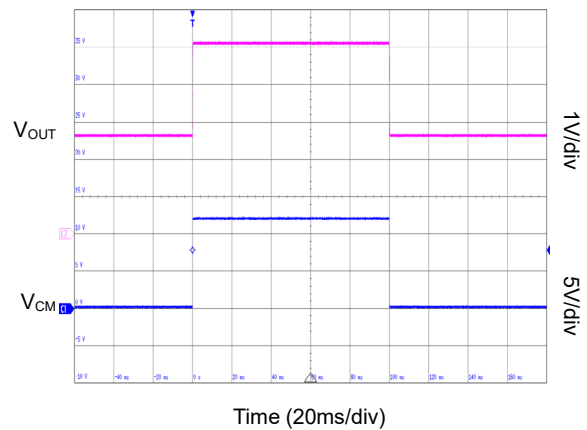

Figure 15. Solenoid Drive Current Sense Input and Output Signals

Special Precautions

For high-precision measurement, the following items need to be check first.

1. Choose a precision current-sense resistor.
2. Provide a precision reference voltage for REF1 and REF2.
3. Optimize the layout and routing between the input pins and the sensing resistor.
4. Place adequate decoupling capacitor between VS and GND pin.

Power Supply Recommendations

The SGM840 series can accurately measure signals over a wide range of common-mode voltages, from -4V to 80V, independent of the power supply voltage (V_S). For instance, even if the SGM840 is powered by a 5V supply, it can handle common-mode voltages as low as -4V and as high as 80V. The output voltage range is subjected to the power supply.

LAYOUT

Layout Guidelines

Current sense connections must be made using Kelvin or 4-wire connection between the input pins and the sensing resistor. This connection method eliminates the extra induced impedance, ensuring that only the current-sensing resistor impedance can be detected between the input pins. Figure 16 shows the good and bad connections.

Place a decoupling capacitor as close as possible to the VS and GND pins. A 0.1µF bypass capacitor for this supply is recommended.

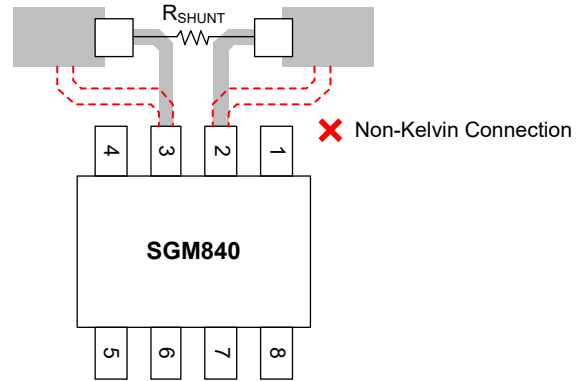

Figure 16. Shunt Connections to the SGM840

REVISION HISTORY

NOTE: Page numbers for previous revisions may differ from page numbers in the current version.

| MARCH 2026 – REV.A.2 to REV.A.3 | Page |
|---|-------------|
| Added MSOP-8 package | 1-4, 19, 20 |
| <hr/> | |
| AUGUST 2025 – REV.A.1 to REV.A.2 | Page |
| Updated Absolute Maximum Ratings section..... | 3 |
| Updated Application Information section..... | 13, 14 |
| <hr/> | |
| DECEMBER 2024 – REV.A to REV.A.1 | Page |
| Added TSSOP-8 package | 1-4, 18, 19 |
| <hr/> | |
| Changes from Original (NOVEMBER 2024) to REV.A | Page |
| Changed from product preview to production data..... | All |

PACKAGE OUTLINE DIMENSIONS

SOIC-8

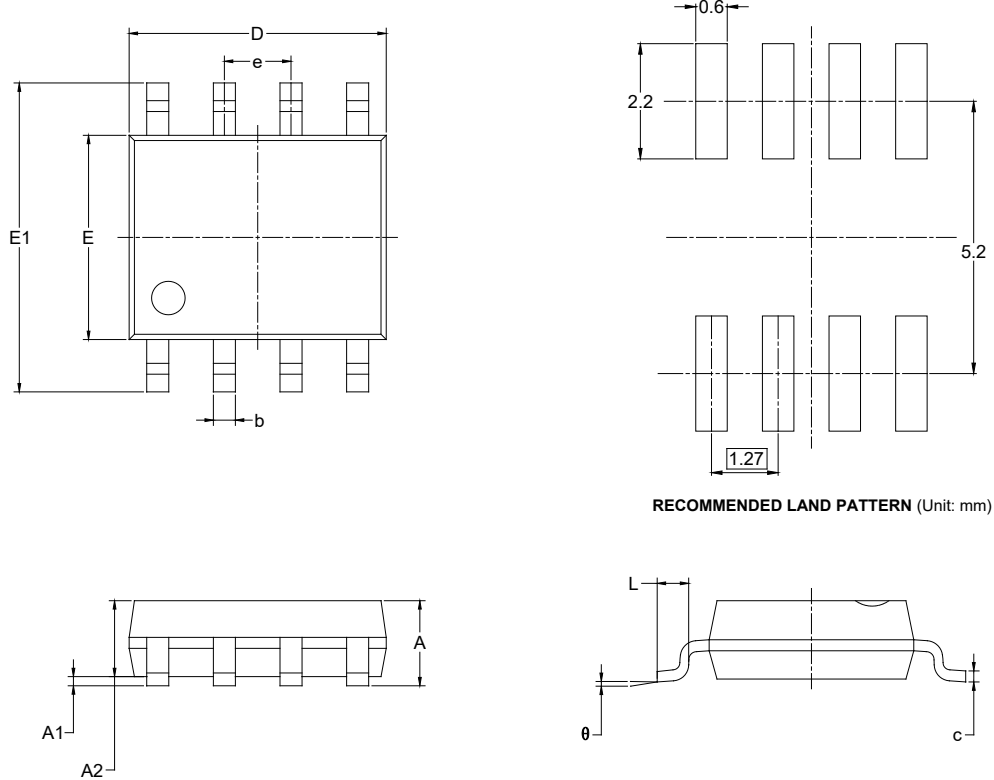

RECOMMENDED LAND PATTERN (Unit: mm)

| Symbol | Dimensions In Millimeters | | Dimensions In Inches | |
|----------|------------------------------|-------|-------------------------|-------|
| | MIN | MAX | MIN | MAX |
| A | 1.350 | 1.750 | 0.053 | 0.069 |
| A1 | 0.100 | 0.250 | 0.004 | 0.010 |
| A2 | 1.350 | 1.550 | 0.053 | 0.061 |
| b | 0.330 | 0.510 | 0.013 | 0.020 |
| c | 0.170 | 0.250 | 0.006 | 0.010 |
| D | 4.700 | 5.100 | 0.185 | 0.200 |
| E | 3.800 | 4.000 | 0.150 | 0.157 |
| E1 | 5.800 | 6.200 | 0.228 | 0.244 |
| e | 1.27 BSC | | 0.050 BSC | |
| L | 0.400 | 1.270 | 0.016 | 0.050 |
| θ | 0° | 8° | 0° | 8° |

NOTES:

1. Body dimensions do not include mode flash or protrusion.
2. This drawing is subject to change without notice.

PACKAGE OUTLINE DIMENSIONS

TSSOP-8

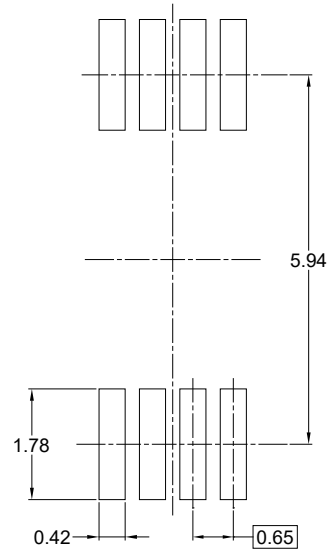
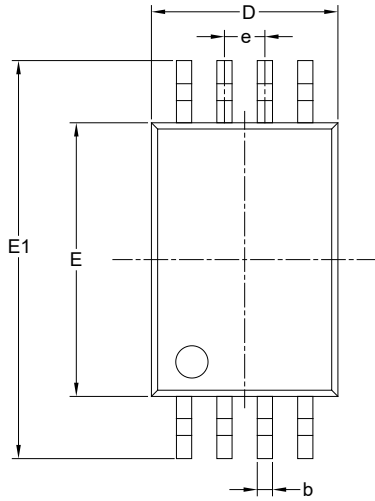

RECOMMENDED LAND PATTERN (Unit: mm)

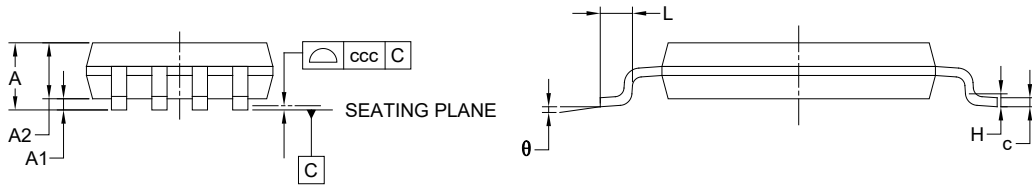

| Symbol | Dimensions In Millimeters | | |
|--------|---------------------------|-----|-------|
| | MIN | NOM | MAX |
| A | - | - | 1.200 |
| A1 | 0.050 | - | 0.150 |
| A2 | 0.800 | - | 1.050 |
| b | 0.190 | - | 0.300 |
| c | 0.090 | - | 0.200 |
| D | 2.900 | - | 3.100 |
| E | 4.300 | - | 4.500 |
| E1 | 6.200 | - | 6.600 |
| e | 0.650 BSC | | |
| L | 0.450 | - | 0.750 |
| H | 0.250 TYP | | |
| θ | 0° | - | 8° |
| ccc | 0.100 | | |

NOTES:

1. This drawing is subject to change without notice.
2. The dimensions do not include mold flashes, protrusions or gate burrs.
3. Reference JEDEC MO-153.

PACKAGE OUTLINE DIMENSIONS

MSOP-8

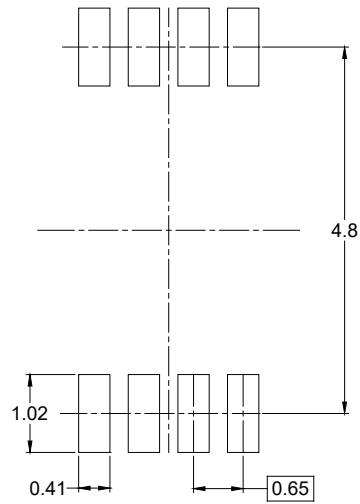
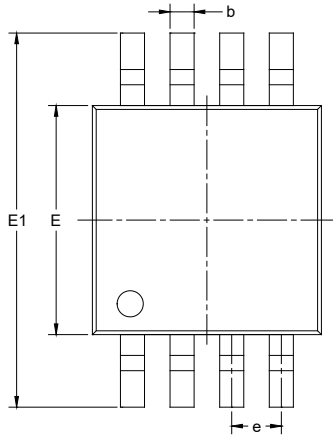

RECOMMENDED LAND PATTERN (Unit: mm)

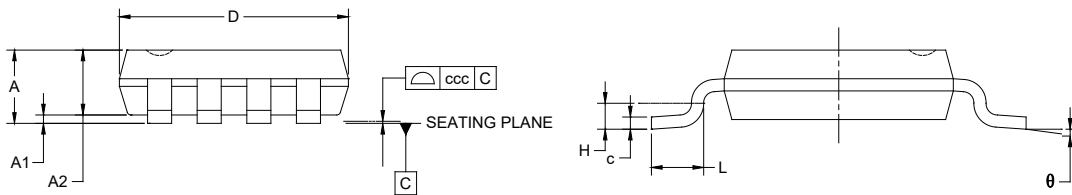

| Symbol | Dimensions In Millimeters | | |
|--------|---------------------------|-----|-------|
| | MIN | NOM | MAX |
| A | - | - | 1.100 |
| A1 | 0.000 | - | 0.150 |
| A2 | 0.750 | - | 0.950 |
| b | 0.220 | - | 0.380 |
| c | 0.080 | - | 0.230 |
| D | 2.800 | - | 3.200 |
| E | 2.800 | - | 3.200 |
| E1 | 4.650 | - | 5.150 |
| e | 0.650 BSC | | |
| L | 0.400 | - | 0.800 |
| H | 0.250 TYP | | |
| θ | 0° | - | 8° |
| ccc | 0.100 | | |

NOTES:

1. This drawing is subject to change without notice.
2. The dimensions do not include mold flashes, protrusions or gate burrs.
3. Reference JEDEC MO-187.

PACKAGE INFORMATION

TAPE AND REEL INFORMATION

REEL DIMENSIONS

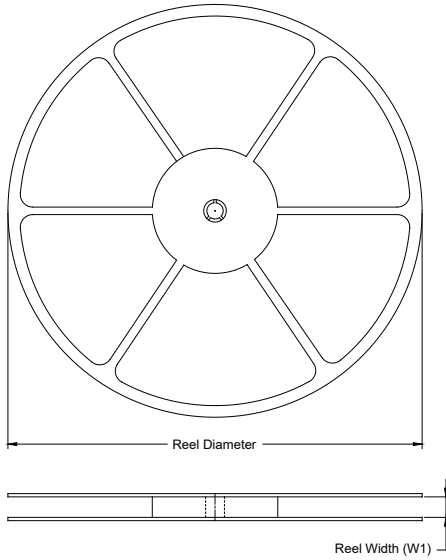

TAPE DIMENSIONS

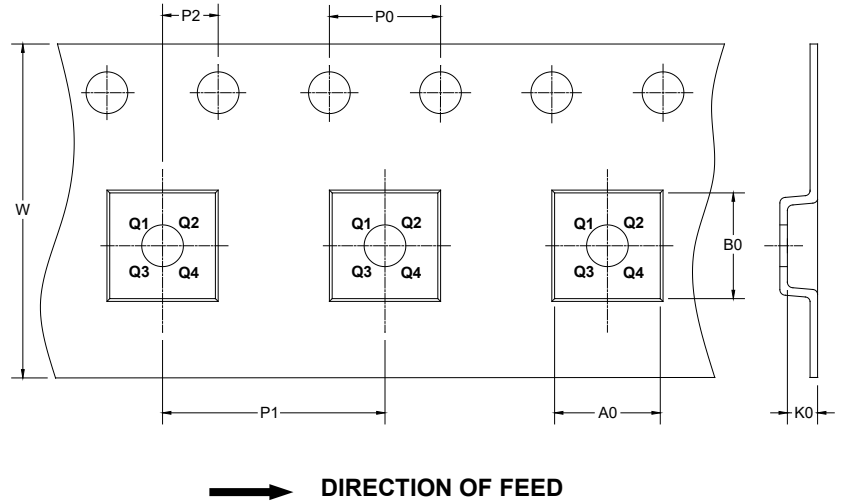

NOTE: The picture is only for reference. Please make the object as the standard.

KEY PARAMETER LIST OF TAPE AND REEL

| Package Type | Reel Diameter | Reel Width W1 (mm) | A0 (mm) | B0 (mm) | K0 (mm) | P0 (mm) | P1 (mm) | P2 (mm) | W (mm) | Pin1 Quadrant |
|--------------|---------------|--------------------|---------|---------|---------|---------|---------|---------|--------|---------------|
| SOIC-8 | 13" | 12.4 | 6.40 | 5.40 | 2.10 | 4.0 | 8.0 | 2.0 | 12.0 | Q1 |
| TSSOP-8 | 13" | 12.4 | 6.76 | 3.30 | 1.80 | 4.0 | 8.0 | 2.0 | 12.0 | Q1 |
| MSOP-8 | 13" | 12.4 | 5.20 | 3.30 | 1.50 | 4.0 | 8.0 | 2.0 | 12.0 | Q1 |

DD0001

PACKAGE INFORMATION

CARTON BOX DIMENSIONS

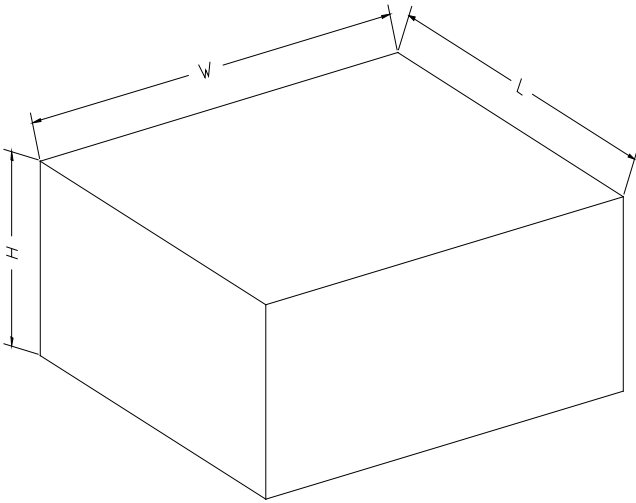

NOTE: The picture is only for reference. Please make the object as the standard.

KEY PARAMETER LIST OF CARTON BOX

| Reel Type | Length (mm) | Width (mm) | Height (mm) | Pizza/Carton |
|-----------|-------------|------------|-------------|--------------|
| 13" | 386 | 280 | 370 | 5 |

DD0002