

GENERAL DESCRIPTION

The SGM2201 is a high voltage and low dropout voltage linear regulator. It is capable of supplying 150mA output current. The operating input voltage is up to 36V. The output voltage can be adjusted from 0.8V to 13.2V by using external resistors.

Other features include logic-controlled shutdown mode current limit and thermal shutdown protection.

The SGM2201 is available in Green TSOT-23-5 and TDFN-2×3-8L packages. It is rated over the -40°C to +85°C temperature range.

FEATURES

- **Input Voltage Range: 2.7V to 36V**
- **Adjustable Output from 0.8V to 13.2V**
- **150mA Guaranteed Output Current**
- **Output Voltage Accuracy: ±2.5% at +25°C**
- **Low Dropout Voltage**
- **Low Power Consumption: 4.2µA (TYP)**
- **Thermal Shutdown Protection**
- **Output Current Limit**
- **-40°C to +85°C Operating Temperature Range**
- **Available in Green TSOT-23-5 and TDFN-2×3-8L Packages**

APPLICATIONS

- Palmtops
- High-Power Boost Applications
- Power Source for Battery-Powered Equipment
- Home Electric/Electronic Appliances

TYPICAL APPLICATION

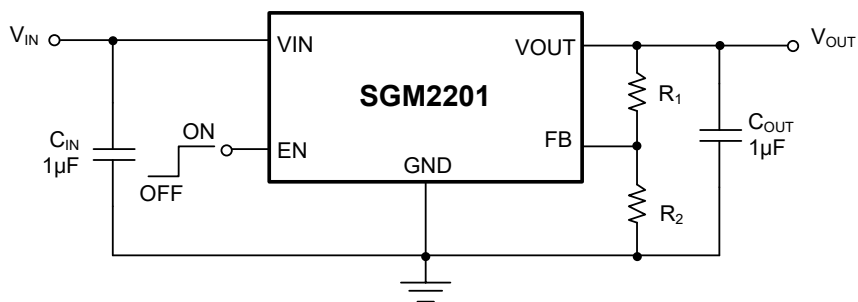

Figure 1. Typical Application Circuit

PACKAGE/ORDERING INFORMATION

MODEL	V _{OUT} (V)	PACKAGE DESCRIPTION	ORDERING NUMBER	MARKING INFORMATION	PACKAGE OPTION
SGM2201	Adjustable	TSOT-23-5	SGM2201-ADJYTN5G/TR	SVDXX	Tape and Reel, 3000
	Adjustable	TDFN-2×3-8L	SGM2201-ADJYTDC8G/TR	SXE XXXX	Tape and Reel, 3000

MARKING INFORMATION

NOTE: XX = Date Code.

YYY X X

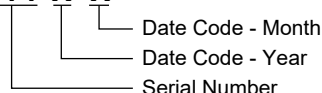

Green (RoHS & HSF): SG Micro Corp defines "Green" to mean Pb-Free (RoHS compatible) and free of halogen substances. If you have additional comments or questions, please contact your SGMICRO representative directly.

ABSOLUTE MAXIMUM RATINGS

VIN, EN to GND	-0.3V to 44V
VOU _T to GND	-0.3V to Min(V _{IN} + 0.3V, 15V)
FB to GND	-0.3V to Min(V _{IN} + 0.3V, 6V)
Power Dissipation, P _D @ T _A = +25°C	
TSOT-23-5	0.7W
TDFN-2×3-8L	2.2W
Package Thermal Resistance	
TSOT-23-5, θ _{JA}	163.1°C/W
TSOT-23-5, θ _{JB}	34.1°C/W
TSOT-23-5, θ _{JC}	67.6°C/W
TDFN-2×3-8L, θ _{JA}	55.7°C/W
TDFN-2×3-8L, θ _{JB}	29.9°C/W
TDFN-2×3-8L, θ _{JC(TOP)}	66.7°C/W
TDFN-2×3-8L, θ _{JC(BOT)}	15°C/W
Junction Temperature	+150°C
Storage Temperature Range	-65°C to +150°C
Lead Temperature (Soldering, 10s)	+260°C
ESD Susceptibility	
HBM	4000V
MM	200V
CDM	1000V

RECOMMENDED OPERATING CONDITIONS

Input Voltage Range	2.7V to 36V
Operating Temperature Range	-40°C to +85°C

OVERSTRESS CAUTION

Stresses beyond those listed in Absolute Maximum Ratings may cause permanent damage to the device. Exposure to absolute maximum rating conditions for extended periods may affect reliability. Functional operation of the device at any conditions beyond those indicated in the Recommended Operating Conditions section is not implied.

ESD SENSITIVITY CAUTION

This integrated circuit can be damaged if ESD protections are not considered carefully. SGMICRO recommends that all integrated circuits be handled with appropriate precautions. Failure to observe proper handling and installation procedures can cause damage. ESD damage can range from subtle performance degradation to complete device failure. Precision integrated circuits may be more susceptible to damage because even small parametric changes could cause the device not to meet the published specifications.

DISCLAIMER

SG Micro Corp reserves the right to make any change in circuit design, or specifications without prior notice.

PIN CONFIGURATIONS

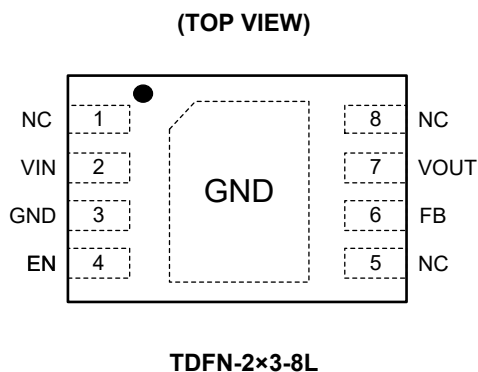
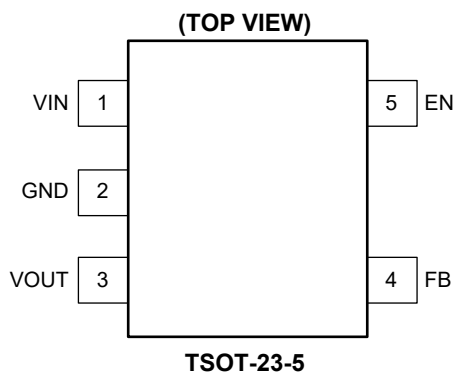

PIN DESCRIPTION

PIN		NAME	FUNCTION
TSOT-23-5	TDFN-2x3-8L		
1	2	VIN	Input Supply Voltage Pin. It is recommended to use a 1μF or larger ceramic capacitor from VIN pin to ground. This ceramic capacitor should be placed as close as possible to VIN pin.
2	3	GND	Ground.
3	7	VOUT	Regulator Output Pin. It is recommended to use a ceramic capacitor with effective capacitance in the range of 1μF to 10μF to get good power supply decoupling. This ceramic capacitor should be placed as close as possible to VOUT pin.
4	6	FB	Feedback Voltage Input Pin. Connect this pin to the midpoint of an external resistor divider to adjust the output voltage. Place the resistors as close as possible to this pin.
5	4	EN	Enable Pin. Drive EN high to turn on the regulator. Drive EN low to turn off the regulator.
–	1, 5, 8	NC	Not Connected.
–	Exposed Pad	GND	Exposed Pad. Connect it to GND internally. Connect it to a large ground plane to maximize thermal performance; this pad is not an electrical connection point.

ELECTRICAL CHARACTERISTICS(V_{IN} = 15V, V_{EN} = 2V, C_{IN} = C_{OUT} = 1μF, Full = -40°C to +85°C, typical values are at T_A = +25°C, unless otherwise noted.)

PARAMETER	SYMBOL	CONDITIONS	TEMP	MIN	TYP	MAX	UNITS
Input Voltage	V _{IN}	V _{OUT} < 3.3V	Full	2.7		32	V
		V _{OUT} ≥ 3.3V	Full	2.7		36	
Output Voltage Accuracy		I _{OUT} = 1mA	+25°C	-2.5		2.5	%
Feedback Voltage	V _{FB}	V _{FB} = V _{OUT} , I _{OUT} = 1mA	+25°C		0.8		V
FB Input Current	I _{FB}	V _{FB} = 0.9V	Full	-15		15	nA
Ground Pin Current		No load	+25°C		4.2	5.4	μA
			Full			6.5	
		I _{OUT} = 50mA	+25°C		4.2		
Maximum Output Current		V _{IN} = V _{OUT} + 2V or 4V, whichever is greater	+25°C	150			mA
Dropout Voltage ⁽²⁾	V _{DROP}	I _{OUT} = 150mA, V _{OUT} ≥ 2.5V	+25°C		1300	1840	mV
			Full			2380	
Line Regulation	$\frac{\Delta V_{OUT}}{\Delta V_{IN} \times V_{OUT}}$	V _{FB} = V _{OUT} = 0.8V, V _{IN} = 4V to 32V, I _{OUT} = 1mA	+25°C		0.005	0.01	%/V
Load Regulation	ΔV _{OUT}	V _{FB} = V _{OUT} = 0.8V, V _{IN} = 4V, I _{OUT} = 1mA to 150mA	+25°C		2	6	mV
Power Supply Rejection Ratio	PSRR	V _{OUT} = 3.3V, I _{OUT} = 10mA	f = 217Hz	+25°C		55	dB
			f = 1kHz	+25°C		40	
Output Voltage Temperature Coefficient	$\frac{\Delta V_{OUT}}{\Delta T_A \times V_{OUT}}$	V _{IN} = V _{OUT} + 2V or 4V, I _{OUT} = 1mA	Full		35		ppm/°C
Shutdown							
EN Input Threshold	V _{IH}	V _{IN} = 2.7V to 36V	Full	1.2			V
	V _{IL}		Full			0.4	
EN Input Bias Current	I _{BH}	V _{EN} = V _{IN}	Full		0.02	1	μA
	I _{BL}	V _{EN} = 0V	Full	-1		1	
Shutdown Supply Current	I _{Q(SHDN)}	V _{EN} = 0V	+25°C		1.5	2	μA
Start-Up Time ⁽²⁾	t _{STR}	No load	+25°C		5		ms
R _{ON} of Discharge MOSFET		V _{IN} = 2.7V, V _{EN} = 0V, I _{OUT} = -1mA	+25°C			75	Ω
Thermal Protection							
Thermal Shutdown Temperature	T _{SHDN}				150		°C
Thermal Shutdown Hysteresis	ΔT _{SHDN}				20		°C

NOTES:

- The dropout voltage is defined as V_{IN} - V_{OUT}, when V_{OUT} is 95% of the value of V_{OUT} for V_{IN} = V_{OUT} + 2V.
- Time needed for V_{OUT} to reach 90% of final value.

TYPICAL PERFORMANCE CHARACTERISTICS

$V_{IN} = 5.3V$, $V_{EN} = 2V$, $V_{OUT} = 3.3V$, $C_{IN} = C_{OUT} = 1\mu F$, $T_A = +25^\circ C$, unless otherwise noted.

Load-Transient Response

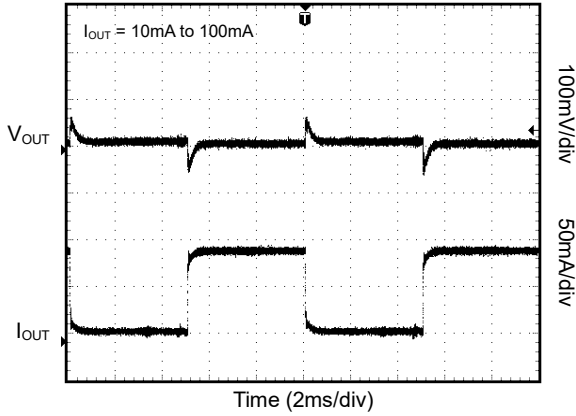

Line-Transient Response

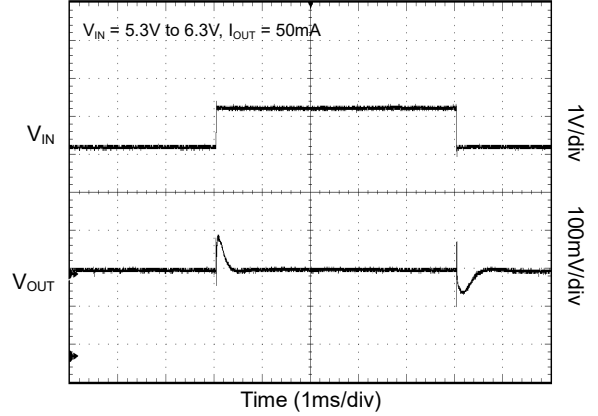

Power-Up/Power-Down Output Waveform

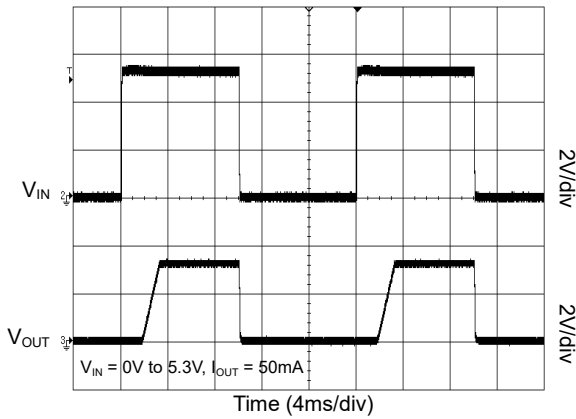

Power Ramp-Up/Ramp-Down Output Waveform

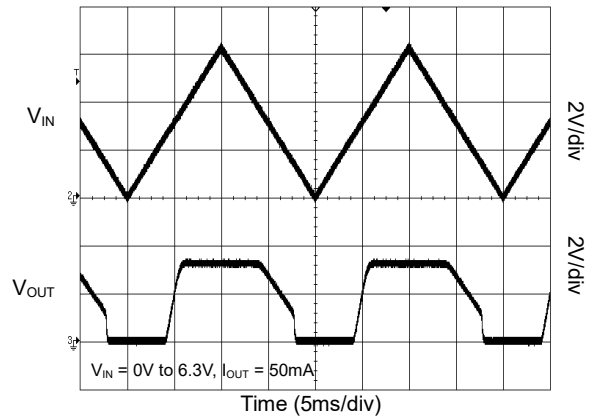

Output Short Waveform

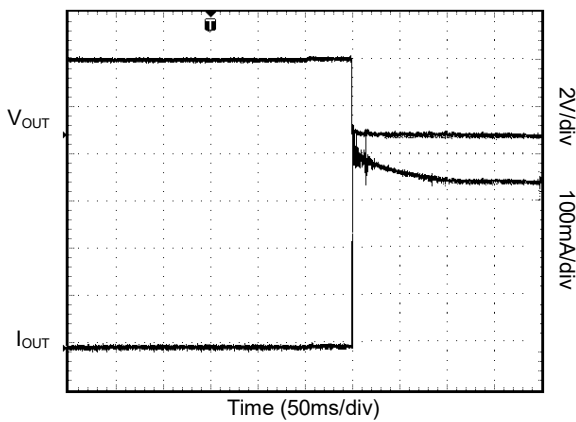

Thermal Protection Waveform

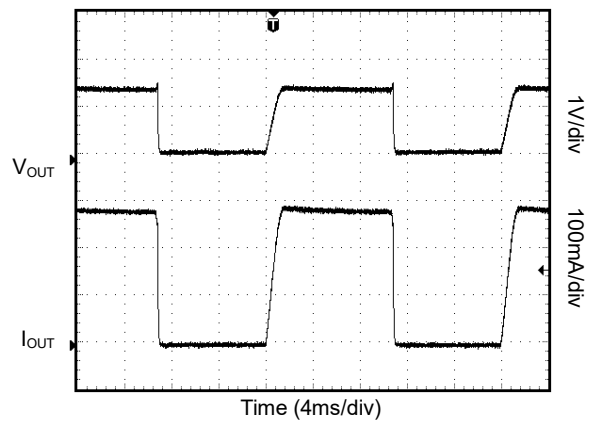

TYPICAL PERFORMANCE CHARACTERISTICS (continued)

$V_{IN} = 5.3V$, $V_{EN} = 2V$, $V_{OUT} = 3.3V$, $C_{IN} = C_{OUT} = 1\mu F$, $T_A = +25^\circ C$, unless otherwise noted.

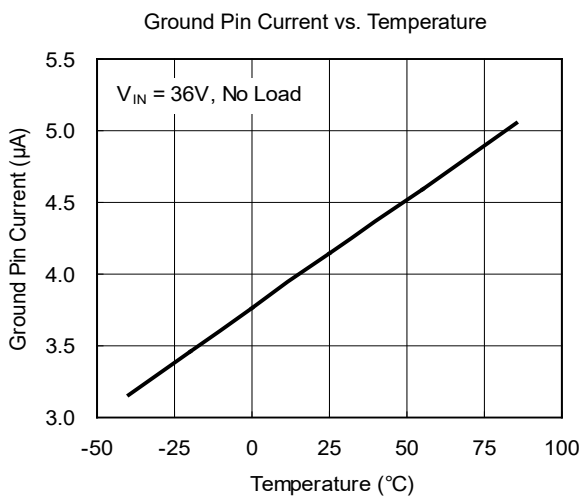
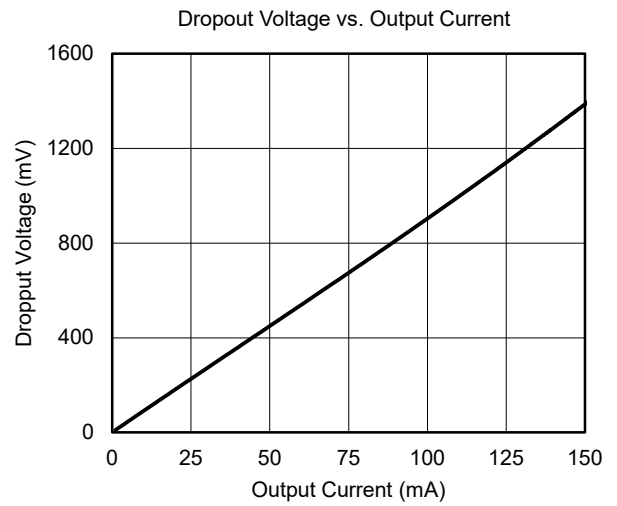
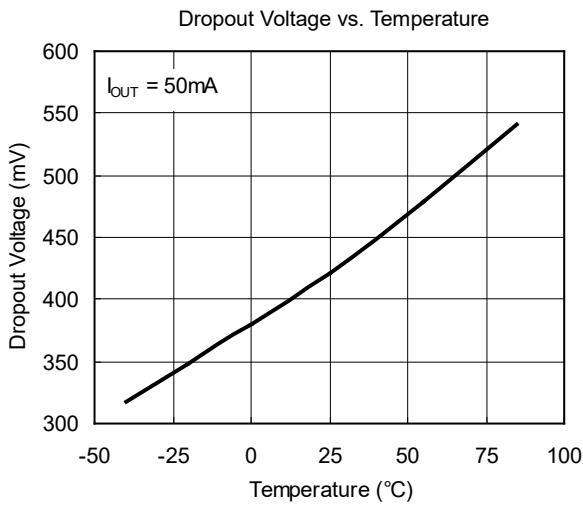
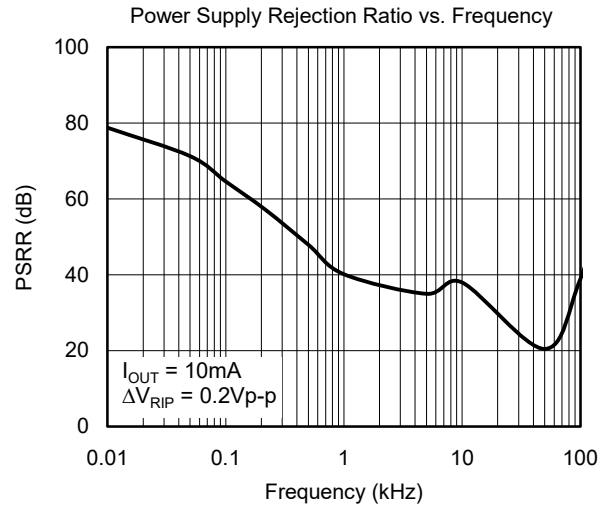
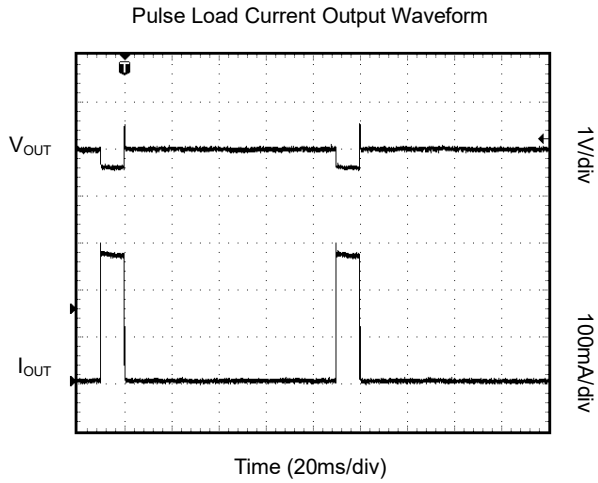

APPLICATION INFORMATION

The SGM2201 is a high input voltage and low dropout LDO and provides 150mA output current. These features make the device a reliable solution to solve many challenging problems in the generation of clean and accurate power supply. The high performance also makes the SGM2201 useful in a variety of applications.

The SGM2201 provides an EN pin as an external chip enable control to enable/disable the device. When the regulator is in shutdown state, the shutdown current consumes as low as 0.02μA (TYP).

Input Capacitor Selection (C_{IN})

The input decoupling capacitor should be placed as close as possible to the IN pin for ensuring the device stability. A 1μF to 10μF X7R or X5R ceramic capacitor is selected to get good dynamic performance.

When V_{IN} is required to provide large current instantaneously, a large effective input capacitor is required. Multiple input capacitors can limit the input tracking inductance. Adding more input capacitors is available to restrict the ringing and to keep it below the device absolute maximum ratings.

Output Capacitor Selection (C_{OUT})

The output decoupling capacitor should be placed as close as possible to the OUT pin. A 1μF to 10μF X7R or X5R ceramic capacitor is selected to get good dynamic performance. For ceramic capacitor, temperature, DC bias and package size will change the effective capacitance, so enough margin of C_{OUT} must be considered in design. Additionally, C_{OUT} with larger capacitance and lower ESR will help increase the high frequency PSRR and improve the load transient response.

Enable Operation

The EN pin of the SGM2201 is used to enable/disable the device and to deactivate/activate the output automatic discharge function.

When the EN pin voltage is lower than 0.4V, the device is in shutdown state. There is no current flowing from V_{IN} to V_{OUT} pins. In this state, the automatic discharge transistor is active to discharge the output voltage through a 75Ω (TYP) resistor.

When the EN pin voltage is higher than 1.2V, the device is in active state. The output voltage is regulated to expected value and the automatic discharge transistor is turned off.

Adjustable Regulator

The output voltage of the SGM2201 can be adjusted from 0.8V to 13.2V. The FB pin will be connected to two external resistors as shown in Figure 2. The output voltage is determined by the following equation:

$$V_{OUT} = V_{FB} \times \left(1 + \frac{R_1}{R_2} \right) \quad (1)$$

where:

V_{OUT} is output voltage and V_{FB} is the internal voltage reference, $V_{FB} = 0.8V$.

One parallel capacitor (C_1) with R_1 can be used to improve the PSRR, increase the transient response and reduce the output noise. Use $R_2 = 2M\Omega$ to maintain a 0.4μA minimum load.

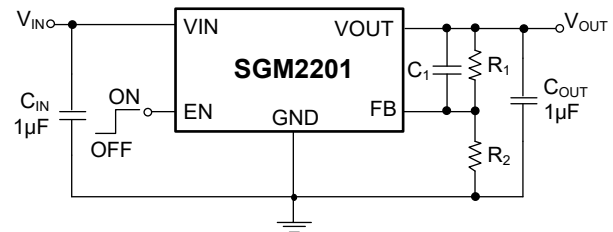

Figure 2. Adjustable Output Voltage Application

Reverse Current Protection

The PMOS power transistor has an inherent body diode. This body diode will be forward biased when $V_{OUT} > V_{IN}$. When $V_{OUT} > V_{IN}$, the reverse current flowing from the OUT pin to the IN pin will damage the SGM2201. If reverse current protection function is needed in application, the circuit in Figure 3 is good solution to provide reverse current protection.

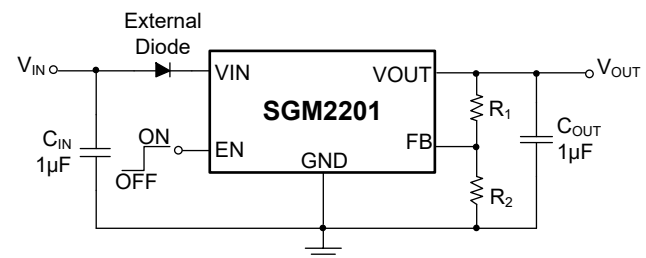

Figure 3. Reverse Protection Reference Design

Thermal Shutdown

When the die temperature exceeds the threshold value of thermal shutdown, the SGM2201 will be in shutdown state and it will remain in this state until the die temperature decreases to +130°C.

REVISION HISTORY

NOTE: Page numbers for previous revisions may differ from page numbers in the current version.

OCTOBER 2025 – REV.A to REV.A.1	Page
Updated Absolute Maximum Ratings section.....	2
Updated Application Information section.....	7

Changes from Original (APRIL 2017) to REV.A	
Changed from product preview to production data.....	All

PACKAGE OUTLINE DIMENSIONS

TSOT-23-5

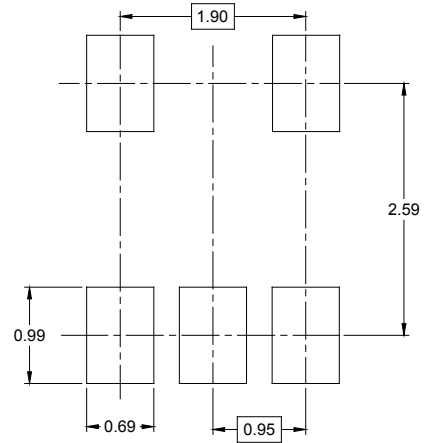
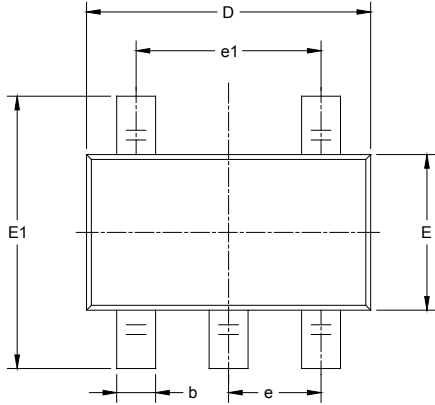

RECOMMENDED LAND PATTERN (Unit: mm)

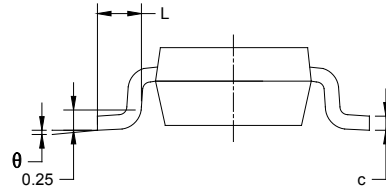
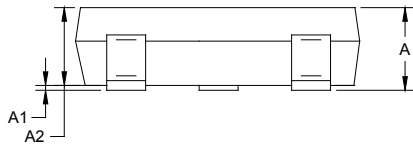

Symbol	Dimensions In Millimeters		Dimensions In Inches	
	MIN	MAX	MIN	MAX
A	0.700	0.900	0.028	0.035
A1	0.000	0.100	0.000	0.004
A2	0.700	0.800	0.028	0.031
b	0.350	0.500	0.014	0.020
c	0.080	0.200	0.003	0.008
D	2.820	3.020	0.111	0.119
E	1.600	1.700	0.063	0.067
E1	2.650	2.950	0.104	0.116
e	0.950 BSC		0.037 BSC	
e1	1.900 BSC		0.075 BSC	
L	0.300	0.600	0.012	0.024
θ	0°	8°	0°	8°

PACKAGE OUTLINE DIMENSIONS

TDFN-2x3-8L

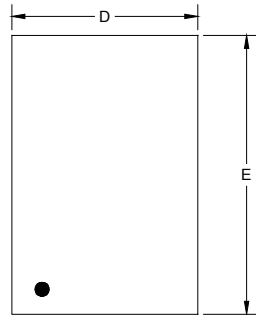

TOP VIEW

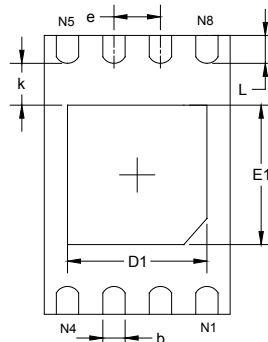

BOTTOM VIEW

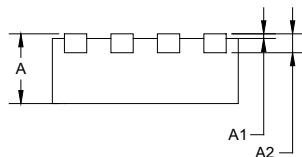

SIDE VIEW

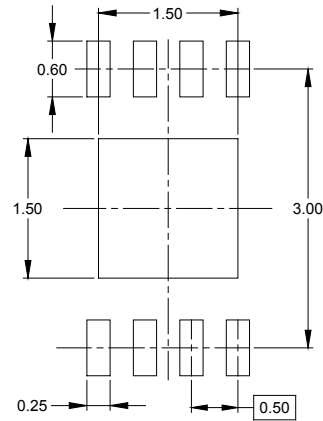

RECOMMENDED LAND PATTERN (Unit: mm)

Symbol	Dimensions In Millimeters		Dimensions In Inches	
	MIN	MAX	MIN	MAX
A	0.700	0.800	0.028	0.031
A1	0.000	0.050	0.000	0.002
A2	0.203 REF		0.008 REF	
D	1.924	2.076	0.076	0.082
D1	1.400	1.600	0.055	0.063
E	2.924	3.076	0.115	0.121
E1	1.400	1.600	0.055	0.063
k	0.200 MIN		0.008 MIN	
b	0.200	0.300	0.008	0.012
e	0.500 TYP		0.020 TYP	
L	0.224	0.376	0.009	0.015

TAPE AND REEL INFORMATION

REEL DIMENSIONS

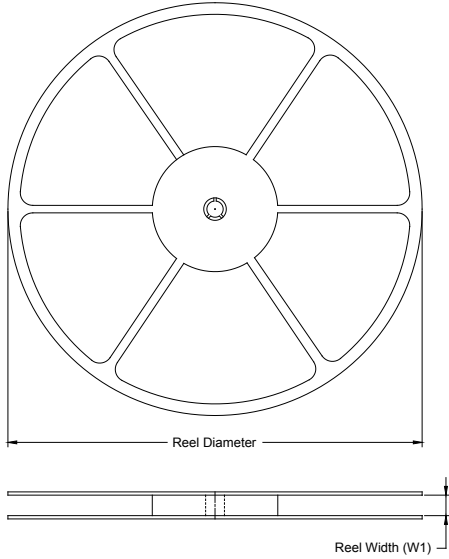

TAPE DIMENSIONS

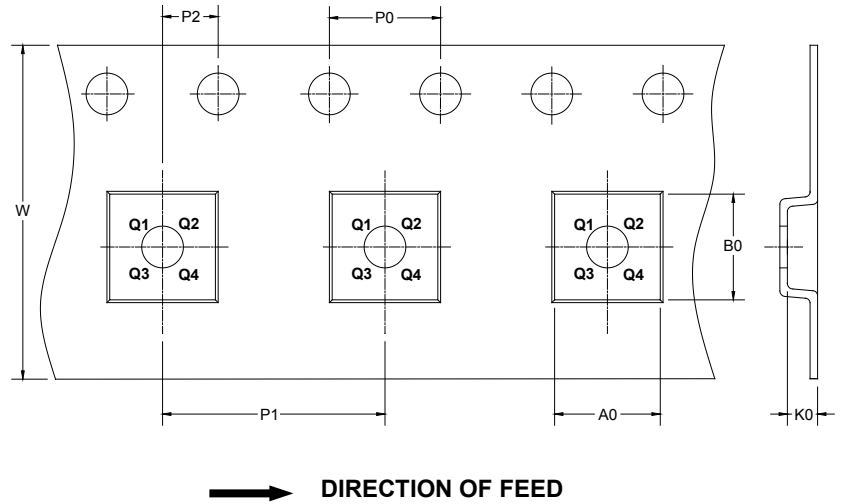

NOTE: The picture is only for reference. Please make the object as the standard.

KEY PARAMETER LIST OF TAPE AND REEL

Package Type	Reel Diameter	Reel Width W1 (mm)	A0 (mm)	B0 (mm)	K0 (mm)	P0 (mm)	P1 (mm)	P2 (mm)	W (mm)	Pin1 Quadrant
TSOT-23-5	7"	9.5	3.17	3.10	1.10	4.0	4.0	2.0	8.0	Q3
TDFN-2×3-8L	7"	9.5	2.30	3.30	1.10	4.0	4.0	2.0	8.0	Q2

DD0001

PACKAGE INFORMATION

CARTON BOX DIMENSIONS

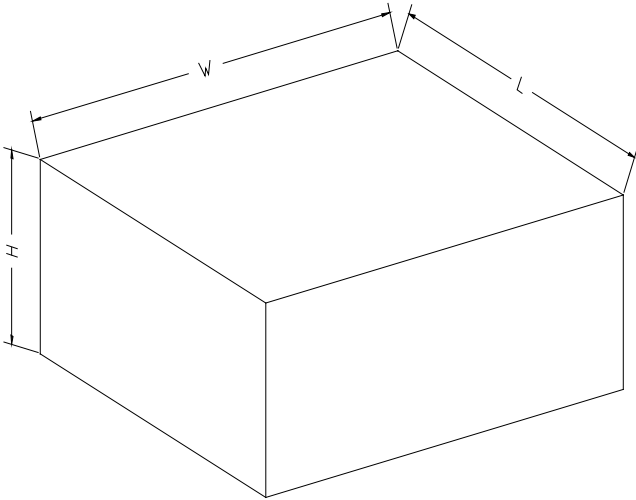

NOTE: The picture is only for reference. Please make the object as the standard.

KEY PARAMETER LIST OF CARTON BOX

Reel Type	Length (mm)	Width (mm)	Height (mm)	Pizza/Carton
7" (Option)	368	227	224	8
7"	442	410	224	18

DD0002