



# SGM2084xQ Automotive 1A, Fast Transient Response, Low Noise and High Accuracy LDO with Power-Good

## GENERAL DESCRIPTION

The SGM2084xQ is a CMOS, fast transient response, low noise and high accuracy linear regulator. It is capable of supplying 1A output current with typical dropout voltage of only 165mV. The operating input voltage range is from 1.5V to 5.5V. The fixed output voltage range is from 0.8V to 4.2V and adjustable output voltage range is from 0.55V to 5.0V.

Other features include an open-drain power-good (PG) output, logic-controlled shutdown mode, current limit and thermal shutdown protection. The SGM2084xQ has automatic discharge function to quickly discharge  $V_{OUT}$  in the disabled status.

This device is AEC-Q100 qualified (Automotive Electronics Council (AEC) standard Q100 Grade 1) and it is suitable for automotive applications.

The SGM2084xQ is available in Green TDFN-2x2-6DL and TDFN-3x3-8KL packages. It operates over an ambient temperature range of -40°C to +125°C.

## APPLICATIONS

General Purpose Automotive & Industrial  
Automotive Entertainment System

## FEATURES

- AEC-Q100 Qualified for Automotive Applications  
Device Temperature Grade 1  
 $T_A = -40^{\circ}\text{C}$  to  $+125^{\circ}\text{C}$
- Operating Input Voltage Range: 1.5V to 5.5V
- Fixed Output from 0.8V to 4.2V
- Adjustable Output from 0.55V to 5.0V
- 1A Output Current
- Output Voltage Accuracy:  $\pm 1\%$  at  $+25^{\circ}\text{C}$
- Quiescent Current: 85 $\mu\text{A}$  (TYP)
- Low Dropout Voltage:  
165mV (TYP) at 1A,  $V_{OUT} = 5\text{V}$
- Current Limiting and Thermal Protection
- Excellent Load and Line Transient Responses
- With Output Automatic Discharge
- UVLO with Hysteresis
- Support Power-Good Indicator Function
- Stable with Small Case Size Ceramic Capacitors
- $-40^{\circ}\text{C}$  to  $+125^{\circ}\text{C}$  Operating Temperature Range
- Available in Green TDFN-2x2-6DL and TDFN-3x3-8KL Packages

## TYPICAL APPLICATION CIRCUITS

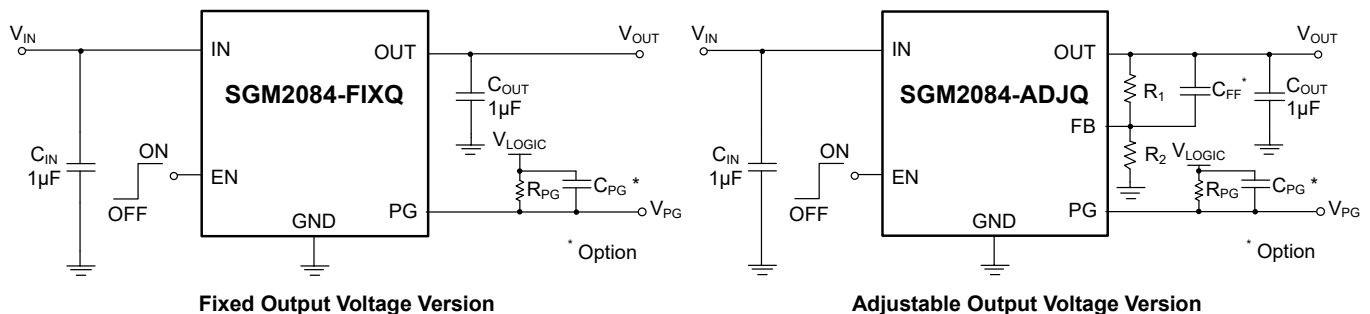

Figure 1. Typical Application Circuits

# Automotive 1A, Fast Transient Response, SGM2084xQ Low Noise and High Accuracy LDO with Power-Good

## PACKAGE/ORDERING INFORMATION

MODEL	PACKAGE DESCRIPTION	SPECIFIED TEMPERATURE RANGE	ORDERING NUMBER	PACKAGE MARKING	PACKING OPTION
SGM2084-0.8Q	TDFN-2×2-6DL	-40°C to +125°C (T <sub>A</sub> )	SGM2084-0.8QTGC6G/TR	10Q XXXX	Tape and Reel, 3000
SGM2084-0.9Q	TDFN-2×2-6DL	-40°C to +125°C (T <sub>A</sub> )	SGM2084-0.9QTGC6G/TR	10R XXXX	Tape and Reel, 3000
SGM2084-1.0Q	TDFN-2×2-6DL	-40°C to +125°C (T <sub>A</sub> )	SGM2084-1.0QTGC6G/TR	10S XXXX	Tape and Reel, 3000
SGM2084-1.05Q	TDFN-2×2-6DL	-40°C to +125°C (T <sub>A</sub> )	SGM2084-1.05QTGC6G/TR	10T XXXX	Tape and Reel, 3000
SGM2084-1.1Q	TDFN-2×2-6DL	-40°C to +125°C (T <sub>A</sub> )	SGM2084-1.1QTGC6G/TR	10U XXXX	Tape and Reel, 3000
SGM2084-1.2Q	TDFN-2×2-6DL	-40°C to +125°C (T <sub>A</sub> )	SGM2084-1.2QTGC6G/TR	10V XXXX	Tape and Reel, 3000
SGM2084-1.5Q	TDFN-2×2-6DL	-40°C to +125°C (T <sub>A</sub> )	SGM2084-1.5QTGC6G/TR	10W XXXX	Tape and Reel, 3000
SGM2084-1.8Q	TDFN-2×2-6DL	-40°C to +125°C (T <sub>A</sub> )	SGM2084-1.8QTGC6G/TR	10X XXXX	Tape and Reel, 3000
SGM2084-2.5Q	TDFN-2×2-6DL	-40°C to +125°C (T <sub>A</sub> )	SGM2084-2.5QTGC6G/TR	10Y XXXX	Tape and Reel, 3000
SGM2084-2.8Q	TDFN-2×2-6DL	-40°C to +125°C (T <sub>A</sub> )	SGM2084-2.8QTGC6G/TR	10Z XXXX	Tape and Reel, 3000
SGM2084-3.0Q	TDFN-2×2-6DL	-40°C to +125°C (T <sub>A</sub> )	SGM2084-3.0QTGC6G/TR	1P0 XXXX	Tape and Reel, 3000
SGM2084-3.3Q	TDFN-2×2-6DL	-40°C to +125°C (T <sub>A</sub> )	SGM2084-3.3QTGC6G/TR	1I0 XXXX	Tape and Reel, 3000
SGM2084-4.2Q	TDFN-2×2-6DL	-40°C to +125°C (T <sub>A</sub> )	SGM2084-4.2QTGC6G/TR	1P1 XXXX	Tape and Reel, 3000
SGM2084-ADJQ	TDFN-2×2-6DL	-40°C to +125°C (T <sub>A</sub> )	SGM2084-ADJQTGC6G/TR	1IN XXXX	Tape and Reel, 3000

# Automotive 1A, Fast Transient Response, SGM2084xQ Low Noise and High Accuracy LDO with Power-Good

## PACKAGE/ORDERING INFORMATION (continued)

MODEL	PACKAGE DESCRIPTION	SPECIFIED TEMPERATURE RANGE	ORDERING NUMBER	PACKAGE MARKING	PACKING OPTION
SGM2084-0.8Q	TDFN-3×3-8KL	-40°C to +125°C (T <sub>A</sub> )	SGM2084-0.8QTHW8G/TR	1P2THW XXXXX XX#XX	Tape and Reel, 4000
SGM2084-0.9Q	TDFN-3×3-8KL	-40°C to +125°C (T <sub>A</sub> )	SGM2084-0.9QTHW8G/TR	1P3THW XXXXX XX#XX	Tape and Reel, 4000
SGM2084-1.0Q	TDFN-3×3-8KL	-40°C to +125°C (T <sub>A</sub> )	SGM2084-1.0QTHW8G/TR	1P4THW XXXXX XX#XX	Tape and Reel, 4000
SGM2084-1.05Q	TDFN-3×3-8KL	-40°C to +125°C (T <sub>A</sub> )	SGM2084-1.05QTHW8G/TR	1P5THW XXXXX XX#XX	Tape and Reel, 4000
SGM2084-1.1Q	TDFN-3×3-8KL	-40°C to +125°C (T <sub>A</sub> )	SGM2084-1.1QTHW8G/TR	1P6THW XXXXX XX#XX	Tape and Reel, 4000
SGM2084-1.2Q	TDFN-3×3-8KL	-40°C to +125°C (T <sub>A</sub> )	SGM2084-1.2QTHW8G/TR	1P7THW XXXXX XX#XX	Tape and Reel, 4000
SGM2084-1.5Q	TDFN-3×3-8KL	-40°C to +125°C (T <sub>A</sub> )	SGM2084-1.5QTHW8G/TR	1P8THW XXXXX XX#XX	Tape and Reel, 4000
SGM2084-1.8Q	TDFN-3×3-8KL	-40°C to +125°C (T <sub>A</sub> )	SGM2084-1.8QTHW8G/TR	1P9THW XXXXX XX#XX	Tape and Reel, 4000
SGM2084-2.5Q	TDFN-3×3-8KL	-40°C to +125°C (T <sub>A</sub> )	SGM2084-2.5QTHW8G/TR	1PATHW XXXXX XX#XX	Tape and Reel, 4000
SGM2084-2.8Q	TDFN-3×3-8KL	-40°C to +125°C (T <sub>A</sub> )	SGM2084-2.8QTHW8G/TR	1PBTHW XXXXX XX#XX	Tape and Reel, 4000
SGM2084-3.0Q	TDFN-3×3-8KL	-40°C to +125°C (T <sub>A</sub> )	SGM2084-3.0QTHW8G/TR	1PCTHW XXXXX XX#XX	Tape and Reel, 4000
SGM2084-3.3Q	TDFN-3×3-8KL	-40°C to +125°C (T <sub>A</sub> )	SGM2084-3.3QTHW8G/TR	1JMTHW XXXXX XX#XX	Tape and Reel, 4000
SGM2084-4.2Q	TDFN-3×3-8KL	-40°C to +125°C (T <sub>A</sub> )	SGM2084-4.2QTHW8G/TR	1PDTHW XXXXX XX#XX	Tape and Reel, 4000
SGM2084-ADJQ	TDFN-3×3-8KL	-40°C to +125°C (T <sub>A</sub> )	SGM2084-ADJQTHW8G/TR	1JLTHW XXXXX XX#XX	Tape and Reel, 4000

### MARKING INFORMATION

NOTE: XXXX = Date Code, Trace Code and Vendor Code. XXXXX = Date Code, Trace Code and Vendor Code. XX#XX = Coordinate Information and Wafer ID Number.

#### TDFN-2×2-6DL

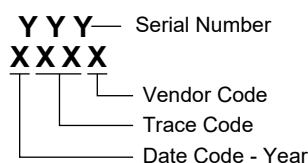

#### TDFN-3×3-8KL

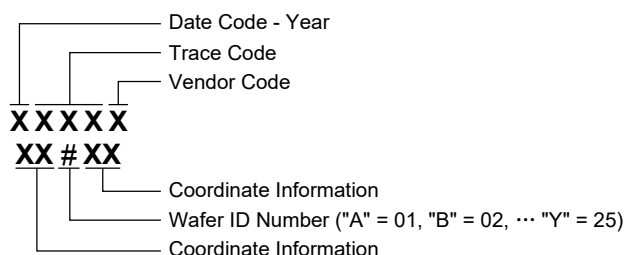

Green (RoHS & HSF): SG Micro Corp defines "Green" to mean Pb-Free (RoHS compatible) and free of halogen substances. If you have additional comments or questions, please contact your SGMICRO representative directly.

# SGM2084xQ Automotive 1A, Fast Transient Response, Low Noise and High Accuracy LDO with Power-Good

## ABSOLUTE MAXIMUM RATINGS

IN to GND .....	-0.3V to 6V
OUT to GND .....	-0.3V to ( $V_{IN} + 0.3V$ )
EN, PG to GND.....	-0.3V to 6V
Power-Good Current.....	$\pm 12mA$
Package Thermal Resistance	
TDFN-2x2-6DL, $\theta_{JA}$ .....	59.2°C/W
TDFN-2x2-6DL, $\theta_{JB}$ .....	26.6°C/W
TDFN-2x2-6DL, $\theta_{JC(TOP)}$ .....	71.4°C/W
TDFN-2x2-6DL, $\theta_{JC(BOT)}$ .....	8.6°C/W
TDFN-3x3-8KL, $\theta_{JA}$ .....	45.7°C/W
TDFN-3x3-8KL, $\theta_{JB}$ .....	21.1°C/W
TDFN-3x3-8KL, $\theta_{JC(TOP)}$ .....	47.1°C/W
TDFN-3x3-8KL, $\theta_{JC(BOT)}$ .....	8.2°C/W
Junction Temperature .....	+150°C
Storage Temperature Range.....	-65°C to +150°C
Lead Temperature (Soldering, 10s) .....	+260°C
ESD Susceptibility <sup>(1)(2)</sup>	
HBM.....	$\pm 8000V$
CDM .....	$\pm 1000V$

1. For human body model (HBM), all pins comply with AEC-Q100-002 specification.
2. For charged device model (CDM), all pins comply with AEC-Q100-011 specification.

## RECOMMENDED OPERATING CONDITIONS

Input Voltage Range .....	1.5V to 5.5V
Enable Input Voltage Range .....	0V to 5.5V
Power-Good Voltage Range .....	0V to 5.5V
Power-Good Current.....	$\pm 10mA$
Input Effective Capacitance, $C_{IN}$ .....	0.5 $\mu F$ (MIN)
Output Effective Capacitance, $C_{OUT}$ .....	0.5 $\mu F$ to 220 $\mu F$
Operating Ambient Temperature Range.....	-40°C to +125°C
Operating Junction Temperature Range.....	-40°C to +150°C

## OVERSTRESS CAUTION

Stresses beyond those listed in Absolute Maximum Ratings may cause permanent damage to the device. Exposure to absolute maximum rating conditions for extended periods may affect reliability. Functional operation of the device at any conditions beyond those indicated in the Recommended Operating Conditions section is not implied.

## ESD SENSITIVITY CAUTION

This integrated circuit can be damaged if ESD protections are not considered carefully. SGMICRO recommends that all integrated circuits be handled with appropriate precautions. Failure to observe proper handling and installation procedures can cause damage. ESD damage can range from subtle performance degradation to complete device failure. Precision integrated circuits may be more susceptible to damage because even small parametric changes could cause the device not to meet the published specifications.

## DISCLAIMER

SG Micro Corp reserves the right to make any change in circuit design, or specifications without prior notice.

# SGM2084xQ Automotive 1A, Fast Transient Response, Low Noise and High Accuracy LDO with Power-Good

## PIN CONFIGURATIONS

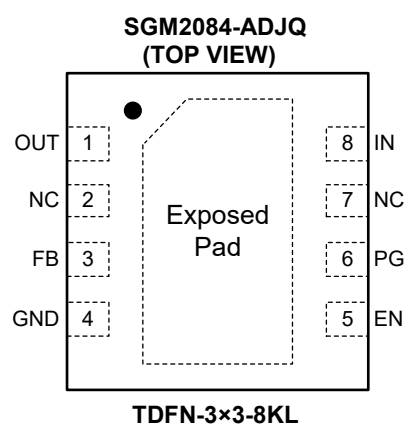
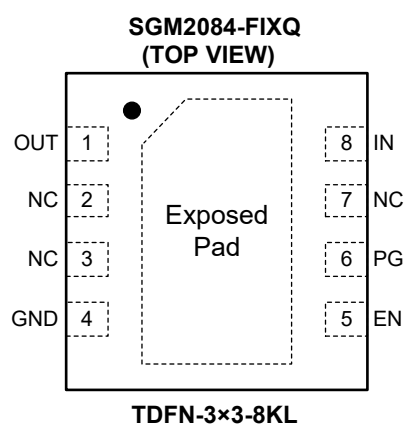
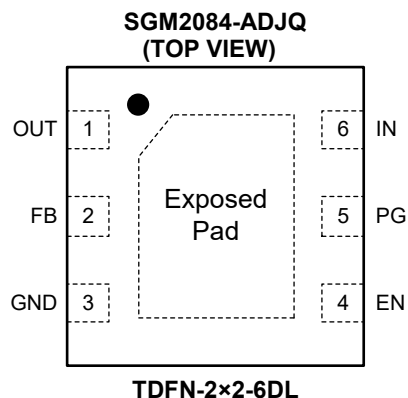
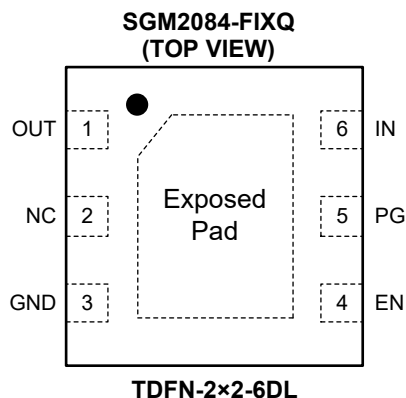

## PIN DESCRIPTION

PIN		NAME	FUNCTION
TDFN-2x2-6DL	TDFN-3x3-8KL		
1	1	OUT	Regulator Output Pin. It is recommended to use a ceramic capacitor with effective capacitance in the range of 0.5 $\mu$ F to 220 $\mu$ F to ensure stability. This ceramic capacitor should be placed as close as possible to OUT pin.
2	3	NC	No Connection (fixed voltage version only).
		FB	Feedback Pin (adjustable voltage version only). Connect this pin to the midpoint of an external resistor divider to adjust the output voltage. Place the resistors as close as possible to this pin.
3	4	GND	Ground.
4	5	EN	Enable Pin. Drive EN high to turn on the regulator. Drive EN low to turn off the regulator.
5	6	PG	Open-Drain Power-Good Output Pin. An open-drain output and active high when the output voltage reaches the target voltage.
6	8	IN	Input Supply Voltage Pin. It is recommended to use a 1 $\mu$ F or larger ceramic capacitor from IN pin to ground to get good power supply decoupling. This ceramic capacitor should be placed as close as possible to IN pin.
—	2, 7	NC	No Connection.
Exposed Pad	Exposed Pad	—	Exposed Pad. Connect it to GND internally. Connect it to a large ground plane to maximize thermal performance. This pad is not an electrical connection point.

# Automotive 1A, Fast Transient Response, SGM2084xQ Low Noise and High Accuracy LDO with Power-Good

## FUNCTIONAL BLOCK DIAGRAMS

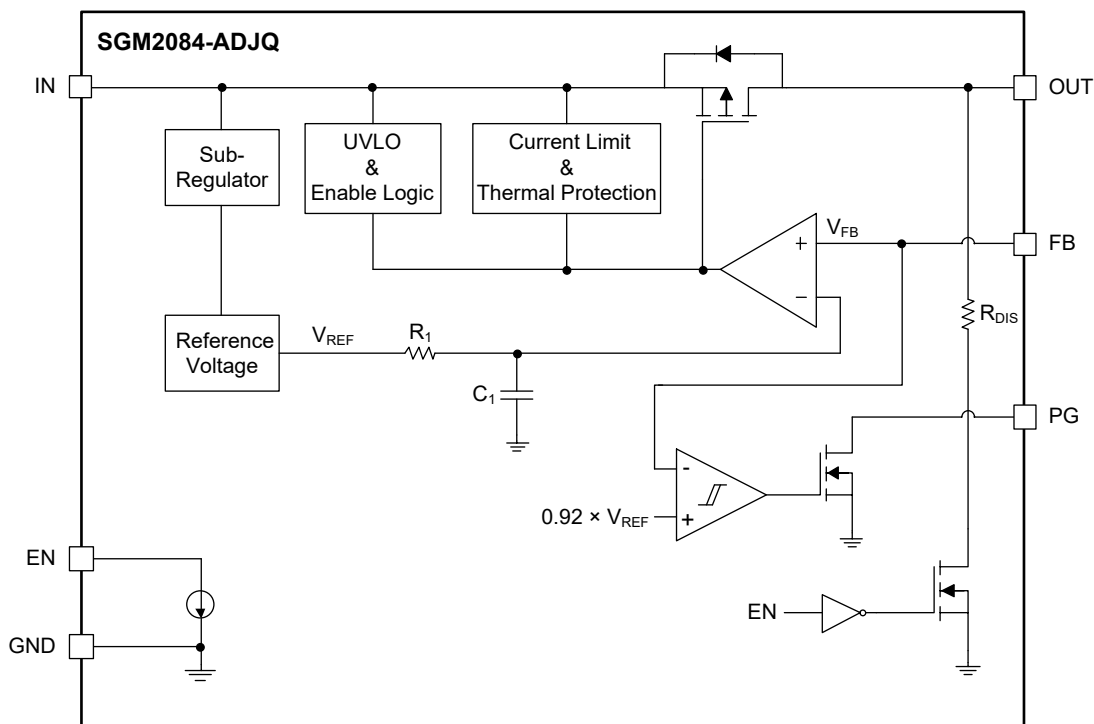

Figure 2. Block Diagram for Adjustable Output Version

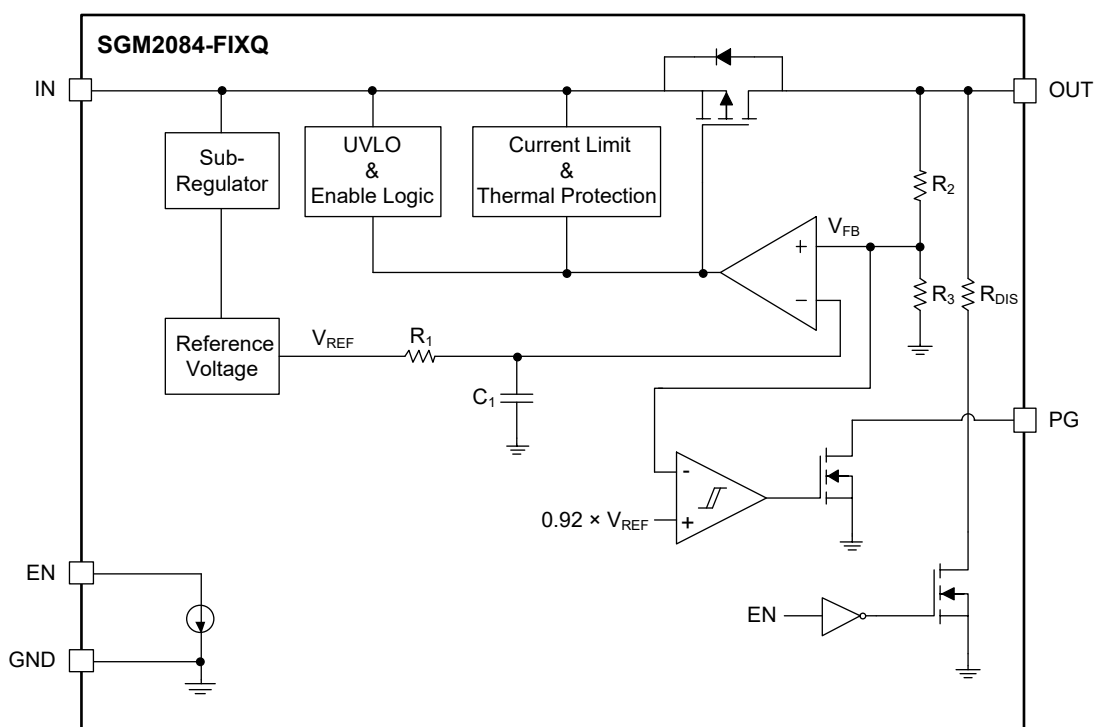

Figure 3. Block Diagram for Fixed Output Version

# Automotive 1A, Fast Transient Response, SGM2084xQ Low Noise and High Accuracy LDO with Power-Good

## ELECTRICAL CHARACTERISTICS

( $V_{IN} = (V_{OUT(NOM)} + 0.5V)$  or 1.5V (whichever is greater),  $C_{IN} = 1\mu F$ ,  $C_{OUT} = 1\mu F$ ,  $C_{FF} = 0nF$ ,  $T_J = -40^\circ C$  to  $+125^\circ C$  <sup>(1)</sup>, typical values are at  $T_J = +25^\circ C$ , unless otherwise noted.)

PARAMETER	SYMBOL	CONDITIONS	MIN	TYP	MAX	UNITS	
Input Supply Voltage Range	$V_{IN}$		1.5		5.5	V	
Output Voltage Range	$V_{OUT}$	SGM2084-FIXQ	0.8		4.2	V	
		SGM2084-ADJQ	0.55		5		
Feedback Voltage	$V_{FB}$	$V_{IN} = (V_{OUT(NOM)} + 0.5V)$ to 5.5V, $I_{OUT} = 10mA$	$T_J = +25^\circ C$	0.5445	0.55	0.5555	V
			$T_J = -40^\circ C$ to $+125^\circ C$	0.5401	0.55	0.5599	
Output Voltage Accuracy	$V_{OUT}$	$V_{IN} = (V_{OUT(NOM)} + 0.5V)$ to 5.5V, $I_{OUT} = 10mA$	$T_J = +25^\circ C$	-1		+1	%
			$T_J = -40^\circ C$ to $+125^\circ C$	-1.8		+1.8	
FB Pin Input Current	$I_{FB}$			1	50	nA	
Under-Voltage Lockout	$V_{UVLO}$	$V_{IN}$ rising		1.31	1.45	V	
		$V_{IN}$ falling	1.15	1.29			
Line Regulation	$\frac{\Delta V_{OUT}}{\Delta V_{IN} \times V_{OUT}}$	$V_{IN} = (V_{OUT(NOM)} + 0.5V)$ to 5.5V, $I_{OUT} = 0.1mA$		0.009	0.2	%/V	
Load Regulation	$\frac{\Delta V_{OUT}}{\Delta I_{OUT} \times V_{OUT}}$	$V_{IN} = (V_{OUT(NOM)} + 0.5V)$ or 2V (whichever is greater), $I_{OUT} = 0.1mA$ to 1A		0.0004	0.003	%/mA	
Dropout Voltage	$V_{DROP}$	$I_{OUT} = 1A$ , when $V_{OUT}$ falls to $95\% \times V_{OUT(NOM)}$	$V_{OUT(NOM)} = 1.8V$		285	460	mV
			$V_{OUT(NOM)} = 3.3V$		191	310	
			$V_{OUT(NOM)} = 5V$		165	260	
Output Current Limit	$I_{LIMIT}$	$V_{IN} = V_{OUT} + 2V$ , $V_{OUT} = 90\% \times V_{OUT(NOM)}$	1	1.9		A	
Short-Circuit Current Limit	$I_{SHORT}$	$V_{IN} = V_{OUT(NOM)} + 2V$ , $V_{OUT} = 0V$		555		mA	
Quiescent Current	$I_Q$	$I_{OUT} = 0mA$	$T_J = -40^\circ C$ to $+85^\circ C$		85	300	$\mu A$
			$T_J = -40^\circ C$ to $+125^\circ C$		85	800	
Shutdown Current	$I_{SHDN}$	$V_{EN} = 0V$		0.22	5	$\mu A$	
Enable Threshold Voltage	$V_{IH}$	EN input voltage high	1		5.5	V	
	$V_{IL}$	EN input voltage low	0		0.4		
Enable Input Current	$I_{EN}$	$V_{EN} = 0V$ , $V_{IN} = 5.5V$		20	500	nA	
		$V_{EN} = 5.5V$ , $V_{IN} = 5.5V$		150	1000	nA	
Output Discharge Resistance	$R_{DIS}$	$V_{EN} = 0V$ , $V_{IN} = 5.5V$		100		$\Omega$	
Turn-On Time	$t_{ON}$	$V_{OUT(NOM)} = 3.3V$ , from assertion of $V_{EN}$ to $V_{OUT} = 90\% \times V_{OUT(NOM)}$		540	1000	$\mu s$	
PG High Threshold	$PG_{HTH}$	$V_{OUT}$ increasing	86	92	98	$\%V_{FB}$	
PG Low Threshold	$PG_{LTH}$	$V_{OUT}$ decreasing	84	90	96	$\%V_{FB}$	
PG Pin Low-Level Output Voltage	$V_{PG(LO)}$	$V_{IN} \geq 1.5V$ , $I_{SINK} = 2mA$		230	400	mV	
PG Pin Leakage Current	$I_{PG(LKG)}$	$V_{OUT} > PG_{HTH}$ , $V_{PG} = 5.5V$		20	1000	nA	
PG Delay Time Rising	$t_{PGDH}$	Time from $92\% \times V_{OUT}$ to 20% of PG, $V_{IN} = 5.5V$		6		ms	
PG Delay Time Falling	$t_{PGDL}$	Time from $90\% \times V_{OUT}$ to 80% of PG, $V_{IN} = 5.5V$		10		$\mu s$	
Power Supply Rejection Ratio	PSRR	$V_{OUT(NOM)} = 3.3V$ , $V_{IN} = 4.3V$ , Ripple $0.2V_{P-P}$ , $I_{OUT} = 50mA$ , $C_{OUT} = 2.2\mu F$	$f = 1kHz$		60		dB
			$f = 100kHz$		41		
			$f = 1MHz$		37		

# Automotive 1A, Fast Transient Response, SGM2084xQ Low Noise and High Accuracy LDO with Power-Good

## ELECTRICAL CHARACTERISTICS (continued)

( $V_{IN} = (V_{OUT(NOM)} + 0.5V)$  or 1.5V (whichever is greater),  $C_{IN} = 1\mu F$ ,  $C_{OUT} = 1\mu F$ ,  $C_{FF} = 0nF$ ,  $T_J = -40^\circ C$  to  $+125^\circ C$  <sup>(1)</sup>, typical values are at  $T_J = +25^\circ C$ , unless otherwise noted.)

PARAMETER	SYMBOL	CONDITIONS	MIN	TYP	MAX	UNITS	
Output Voltage Noise	$e_n$	$V_{OUT(NOM)} = 0.55V$ , $C_{OUT} = 2.2\mu F$ , $f = 10Hz$ to $100kHz$	$I_{OUT} = 1mA$		24		$\mu V_{RMS}$
			$I_{OUT} = 500mA$		16		
		$V_{OUT(NOM)} = 3.3V$ , $C_{OUT} = 2.2\mu F$ , $f = 10Hz$ to $100kHz$	$I_{OUT} = 1mA$		70		
			$I_{OUT} = 500mA$		67		
Thermal Shutdown Temperature	$T_{SHDN}$	$T_J$ rising		165		$^\circ C$	
Thermal Shutdown Hysteresis	$\Delta T_{SHDN}$	Hysteresis		20		$^\circ C$	

NOTE: 1. Tested under pulse load conditions, so  $T_J \approx T_A$ .

# Automotive 1A, Fast Transient Response, SGM2084xQ Low Noise and High Accuracy LDO with Power-Good

## TYPICAL PERFORMANCE CHARACTERISTICS

$V_{IN} = (V_{OUT(NOM)} + 0.5V)$  or 1.5V (whichever is greater),  $V_{EN} = V_{IN}$ ,  $C_{IN} = 1\mu F$ ,  $C_{OUT} = 1\mu F$ ,  $C_{FF} = 0nF$ ,  $T_J = +25^\circ C$ , unless otherwise noted.

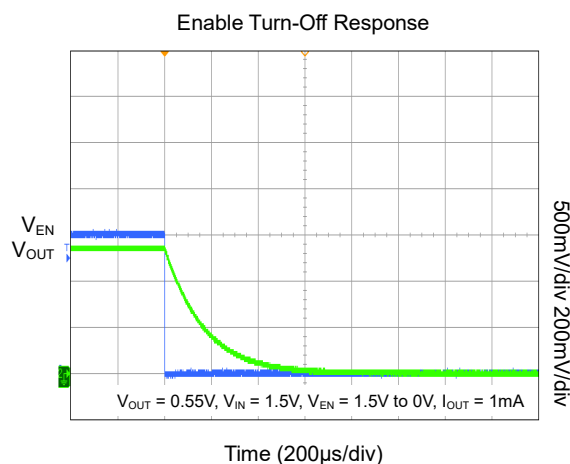
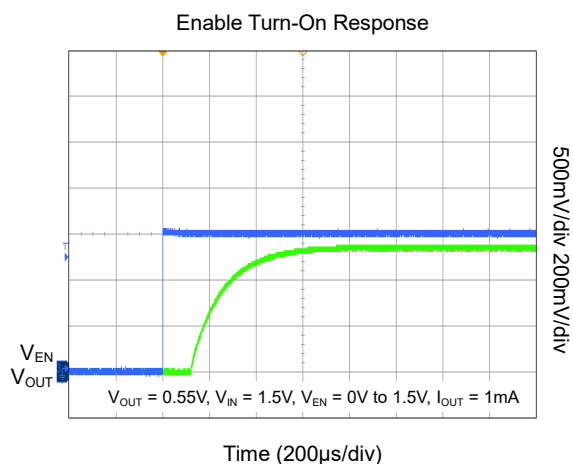
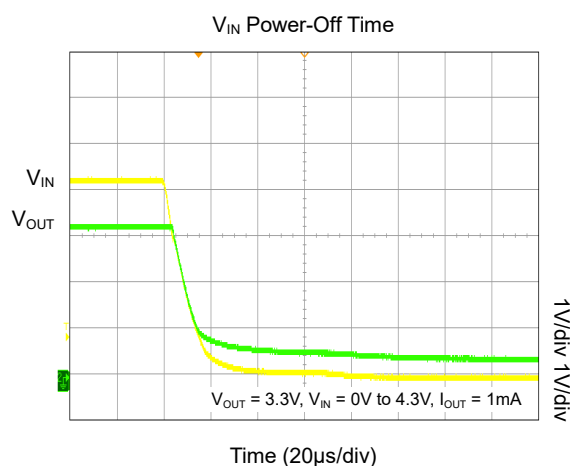
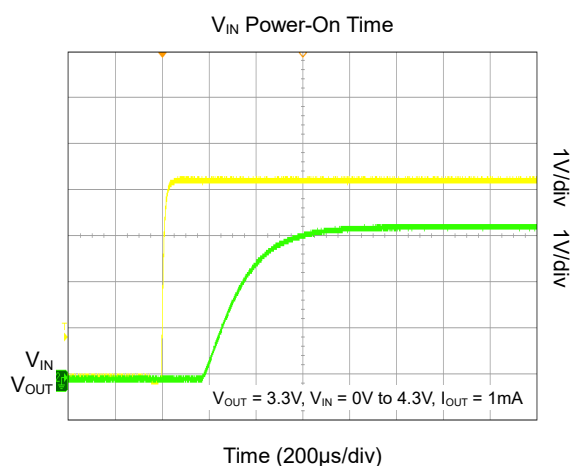
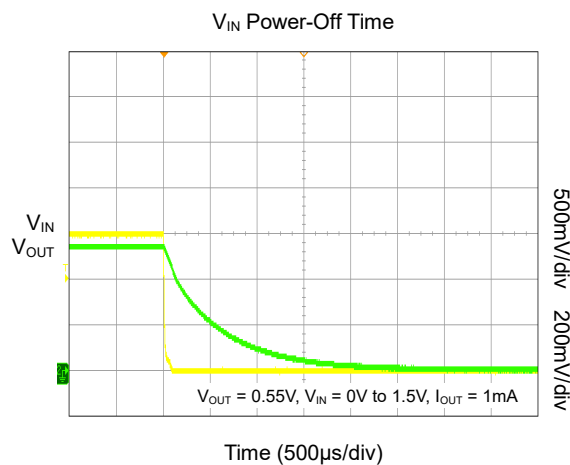
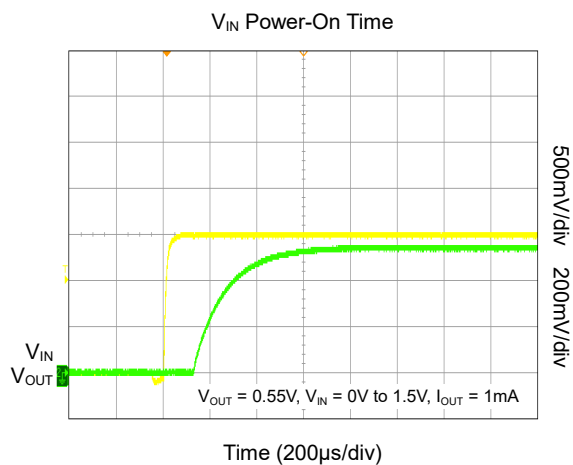

# Automotive 1A, Fast Transient Response, SGM2084xQ Low Noise and High Accuracy LDO with Power-Good

## TYPICAL PERFORMANCE CHARACTERISTICS (continued)

$V_{IN} = (V_{OUT(NOM)} + 0.5V)$  or 1.5V (whichever is greater),  $V_{EN} = V_{IN}$ ,  $C_{IN} = 1\mu F$ ,  $C_{OUT} = 1\mu F$ ,  $C_{FF} = 0nF$ ,  $T_J = +25^\circ C$ , unless otherwise noted.

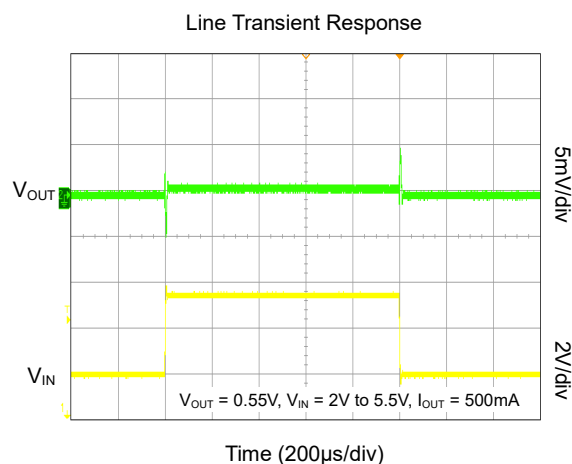
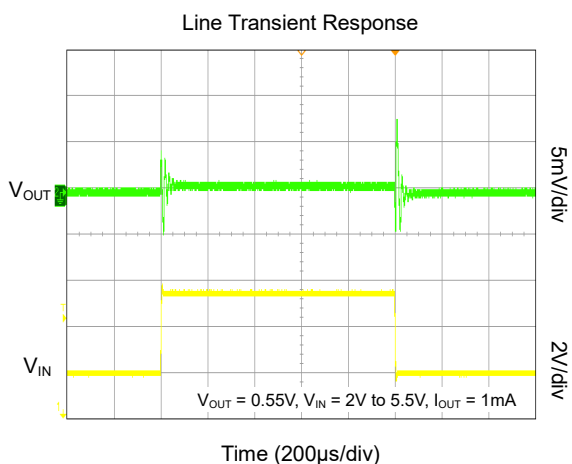
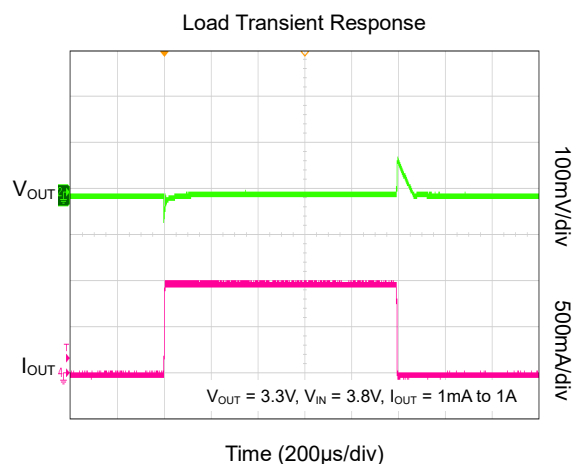
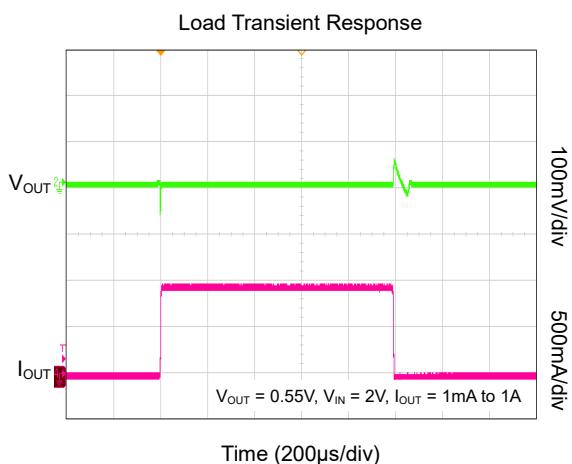
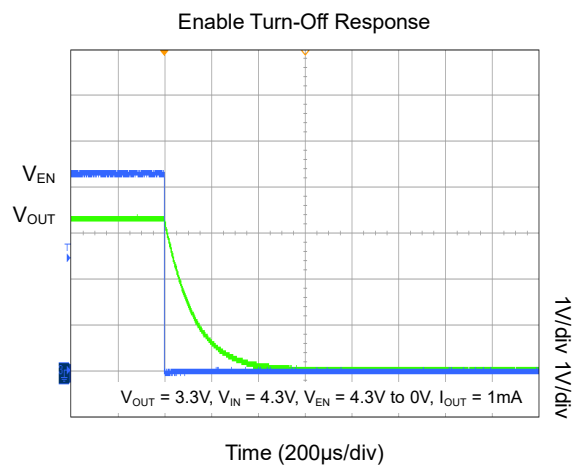
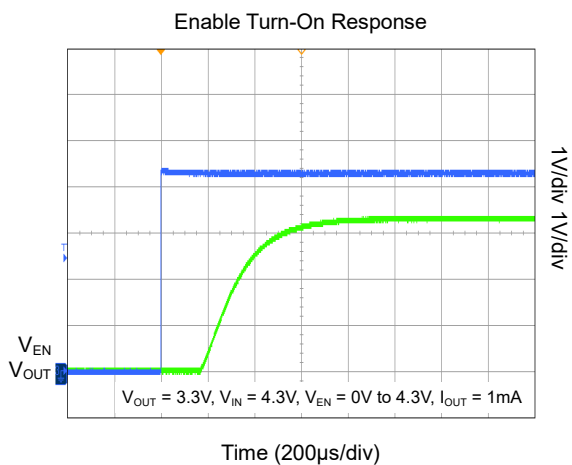

# Automotive 1A, Fast Transient Response, SGM2084xQ Low Noise and High Accuracy LDO with Power-Good

## TYPICAL PERFORMANCE CHARACTERISTICS (continued)

$V_{IN} = (V_{OUT(NOM)} + 0.5V)$  or  $1.5V$  (whichever is greater),  $V_{EN} = V_{IN}$ ,  $C_{IN} = 1\mu F$ ,  $C_{OUT} = 1\mu F$ ,  $C_{FF} = 0nF$ ,  $T_J = +25^\circ C$ , unless otherwise noted.

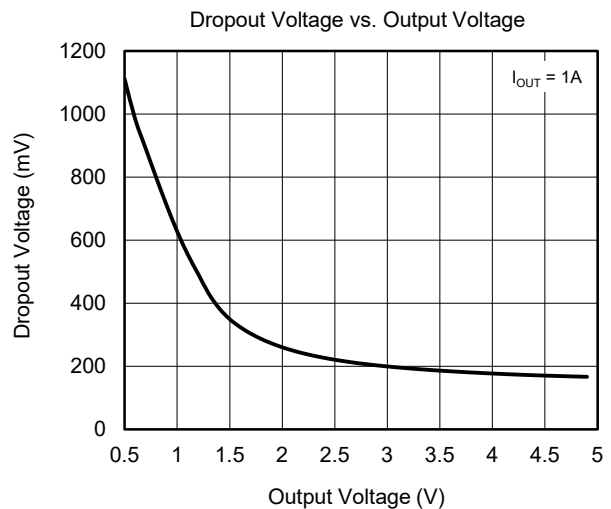
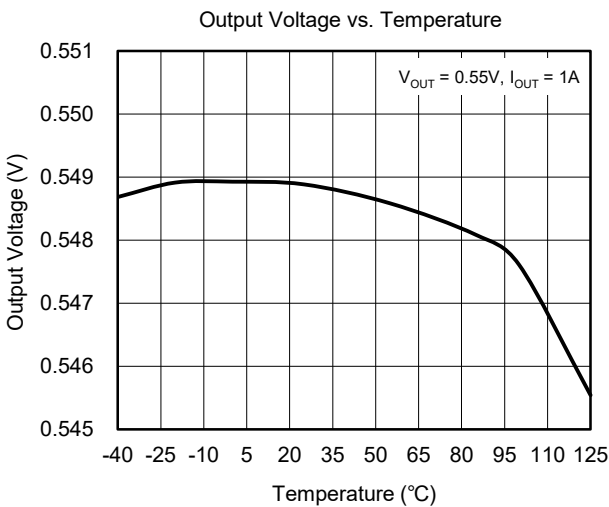
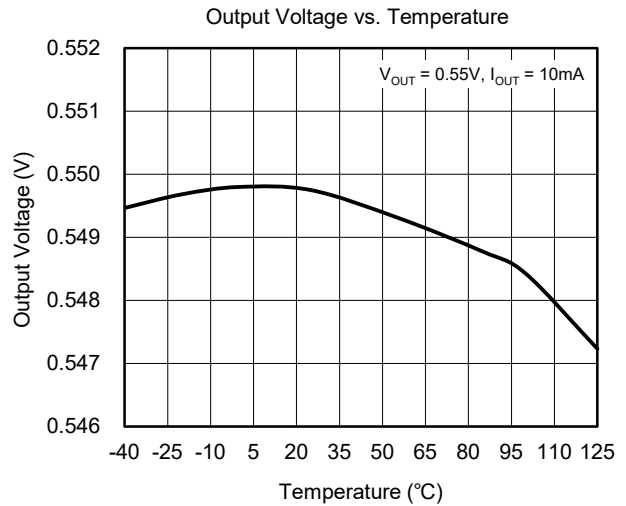
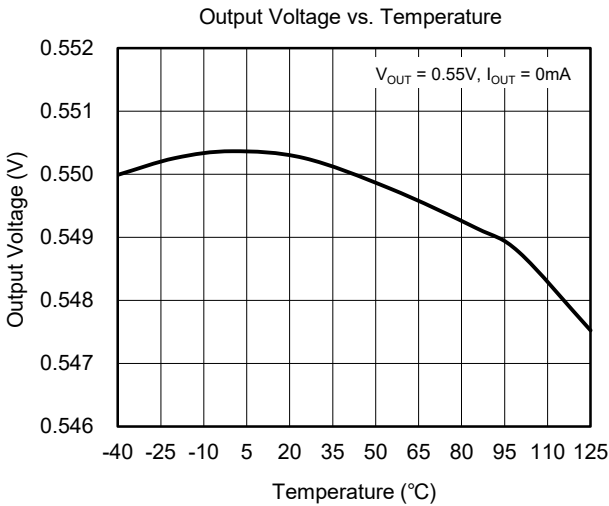
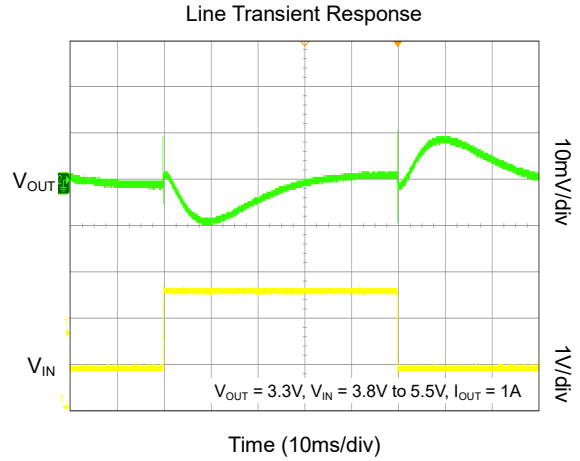
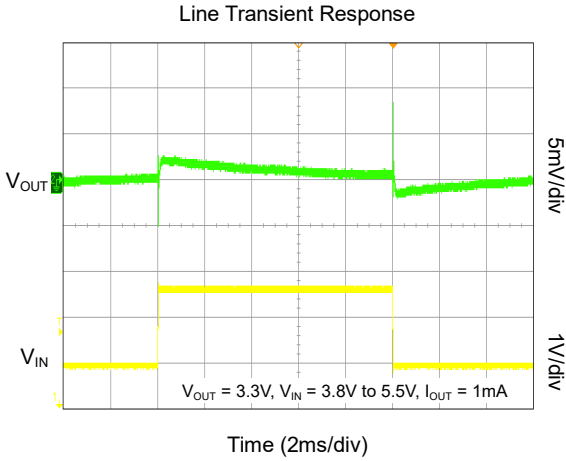

# Automotive 1A, Fast Transient Response, SGM2084xQ Low Noise and High Accuracy LDO with Power-Good

## TYPICAL PERFORMANCE CHARACTERISTICS (continued)

$V_{IN} = (V_{OUT(NOM)} + 0.5V)$  or  $1.5V$  (whichever is greater),  $V_{EN} = V_{IN}$ ,  $C_{IN} = 1\mu F$ ,  $C_{OUT} = 1\mu F$ ,  $C_{FF} = 0nF$ ,  $T_J = +25^\circ C$ , unless otherwise noted.

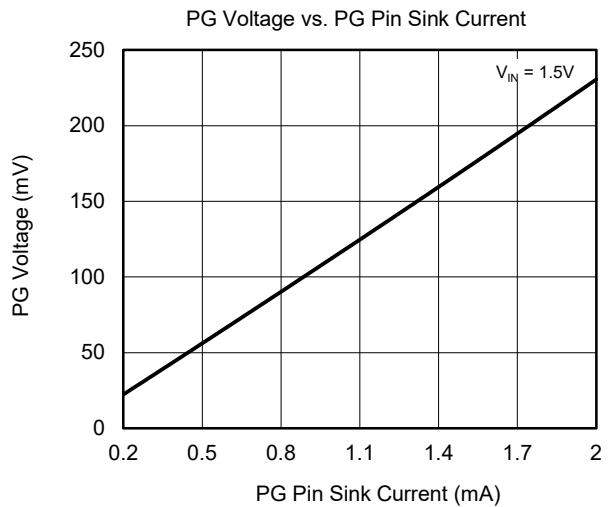
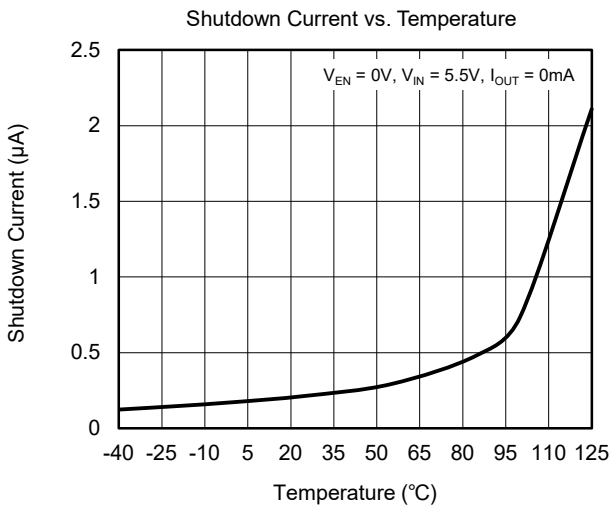
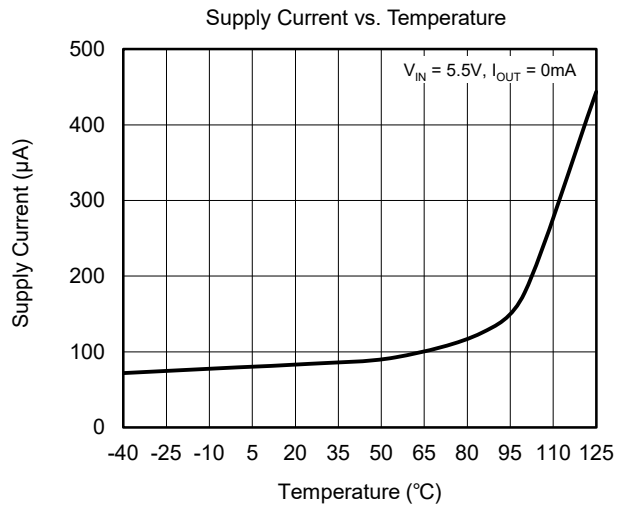
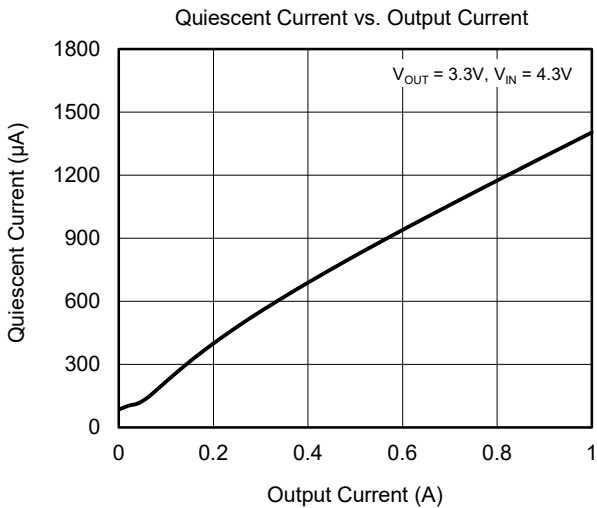
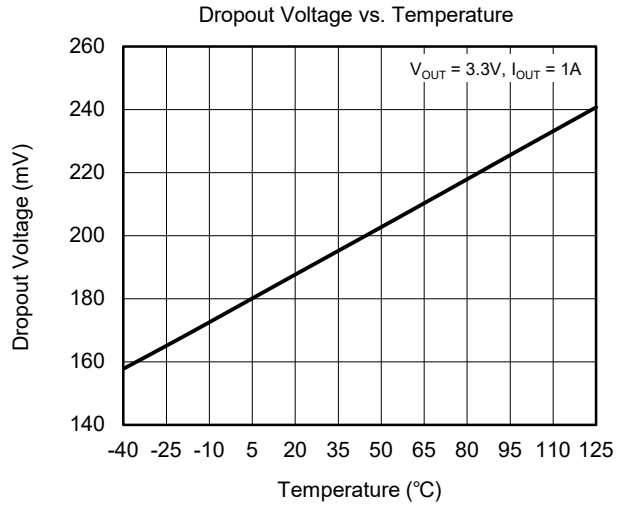
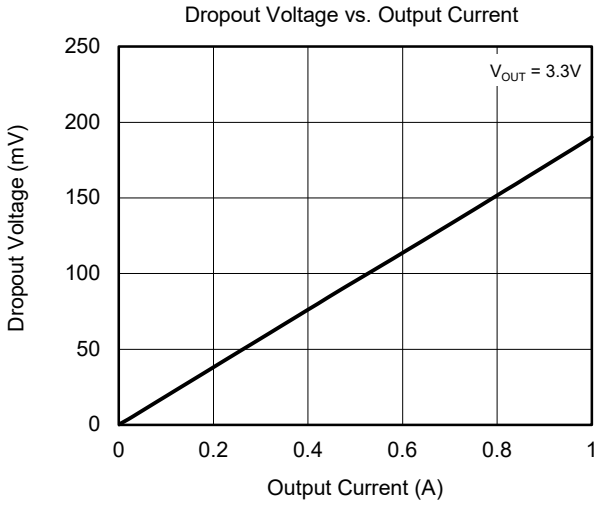

# Automotive 1A, Fast Transient Response, SGM2084xQ Low Noise and High Accuracy LDO with Power-Good

## TYPICAL PERFORMANCE CHARACTERISTICS (continued)

$V_{IN} = (V_{OUT(NOM)} + 0.5V)$  or  $1.5V$  (whichever is greater),  $V_{EN} = V_{IN}$ ,  $C_{IN} = 1\mu F$ ,  $C_{OUT} = 1\mu F$ ,  $C_{FF} = 0nF$ ,  $T_J = +25^\circ C$ , unless otherwise noted.

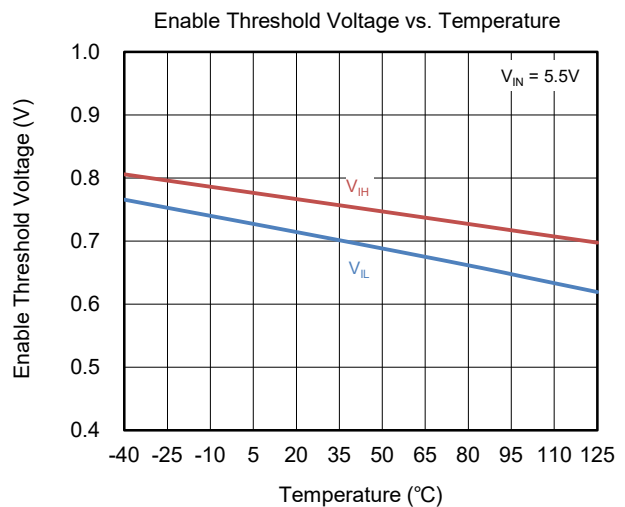
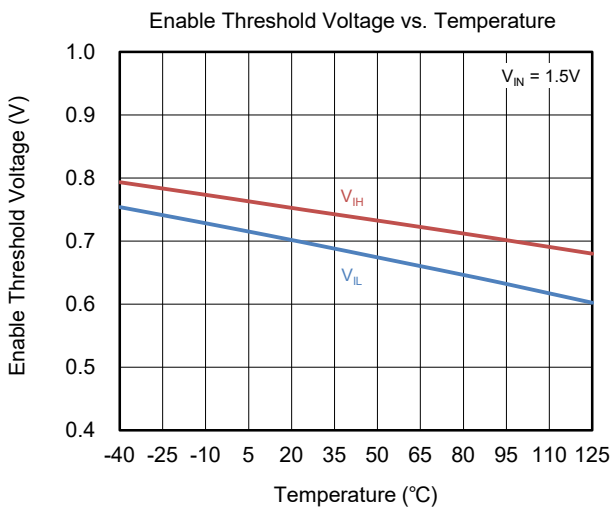
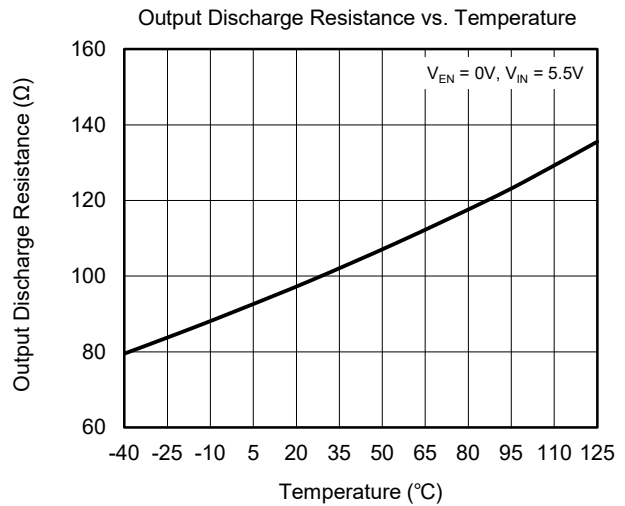
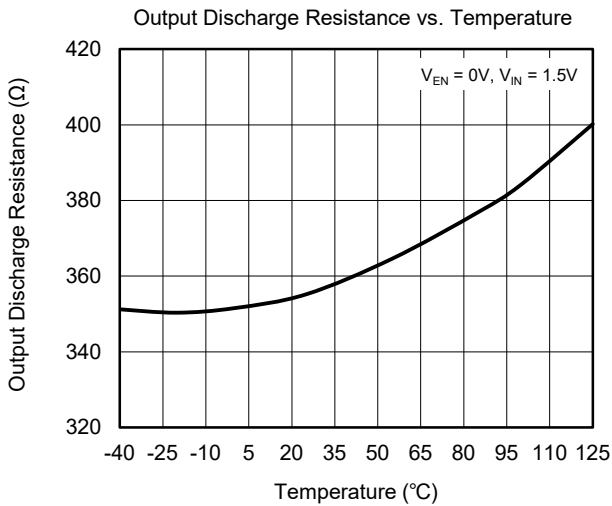
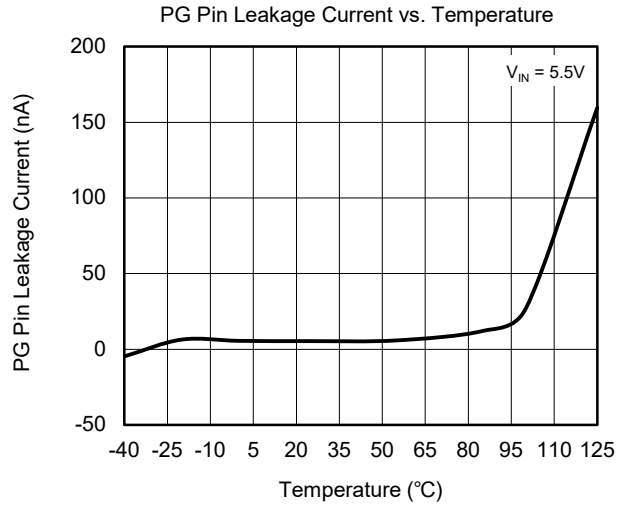
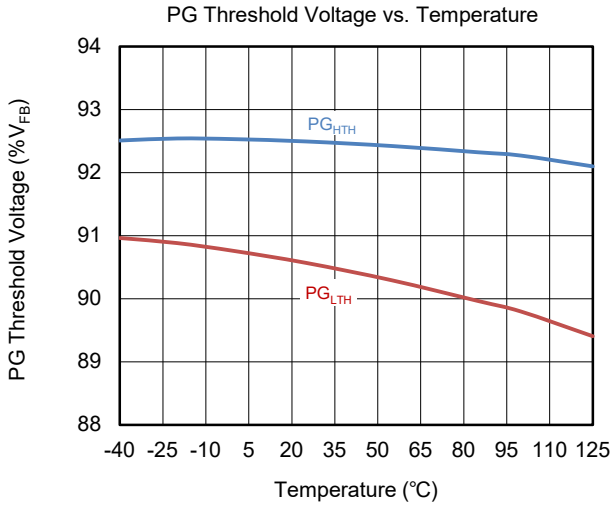

# Automotive 1A, Fast Transient Response, SGM2084xQ Low Noise and High Accuracy LDO with Power-Good

## TYPICAL PERFORMANCE CHARACTERISTICS (continued)

$V_{IN} = (V_{OUT(NOM)} + 0.5V)$  or  $1.5V$  (whichever is greater),  $V_{EN} = V_{IN}$ ,  $C_{IN} = 1\mu F$ ,  $C_{OUT} = 1\mu F$ ,  $C_{FF} = 0nF$ ,  $T_J = +25^\circ C$ , unless otherwise noted.

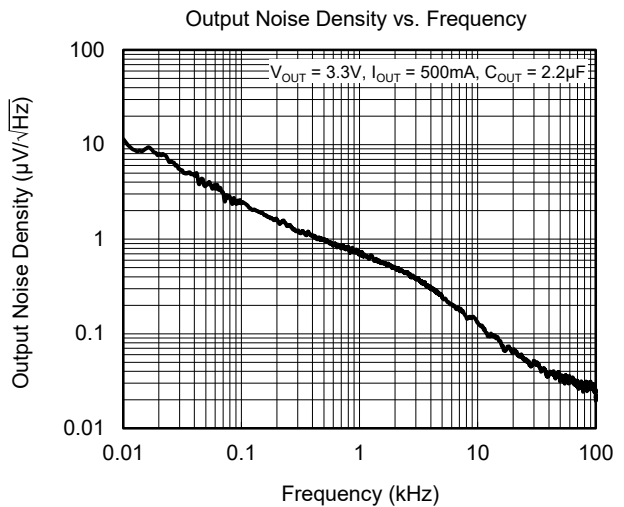
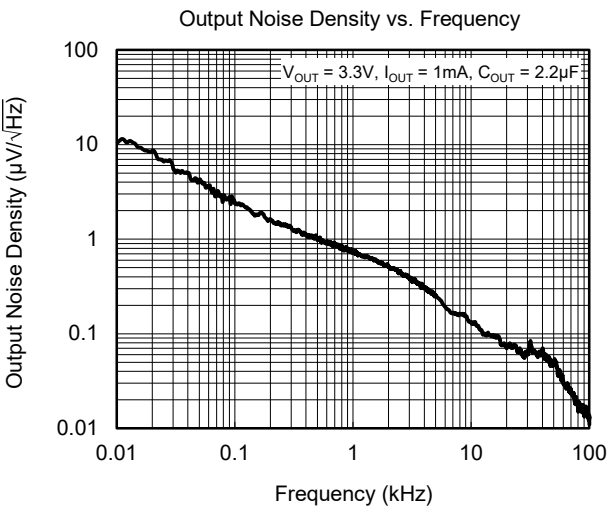
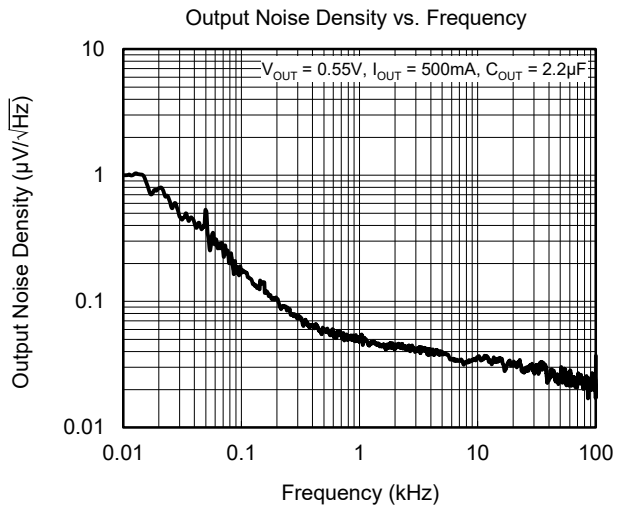
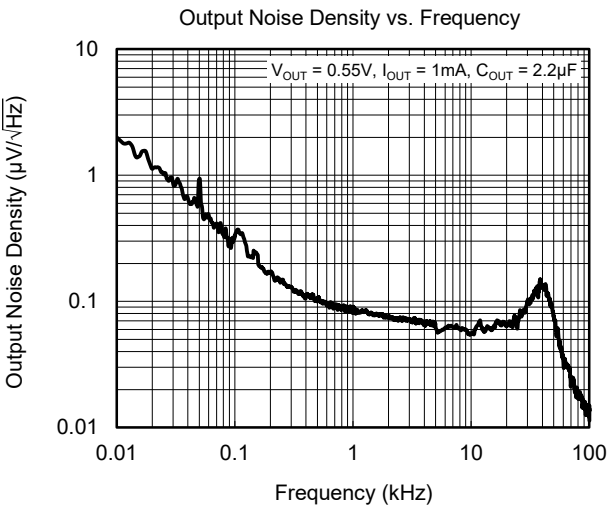
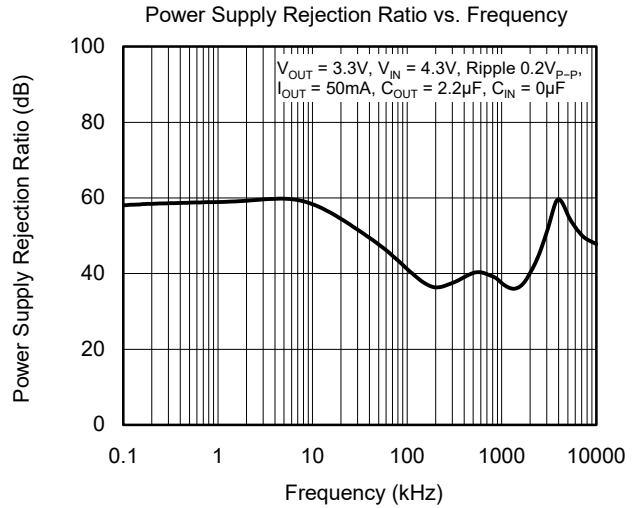
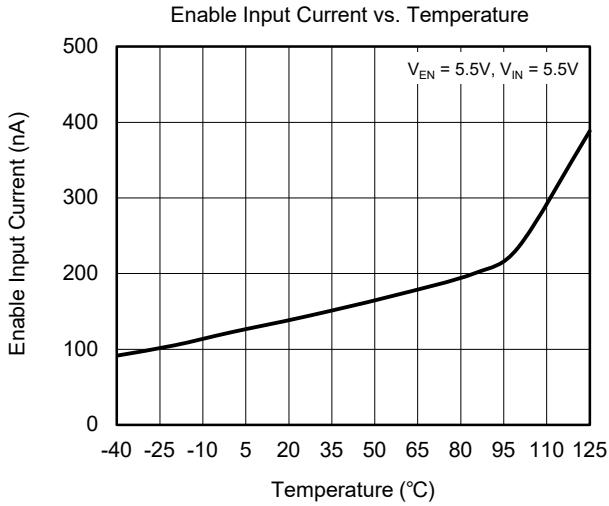

# SGM2084xQ Automotive 1A, Fast Transient Response, Low Noise and High Accuracy LDO with Power-Good

## APPLICATION INFORMATION

The SGM2084xQ is a low noise and low dropout LDO and provides 1A output current. These features make the device a reliable solution to solve many challenging problems in the generation of clean and accurate power supply. The high performance also makes the SGM2084xQ useful in a variety of applications. The SGM2084xQ provides protection functions for output overload and overheating.

The SGM2084xQ provides an EN pin as an external chip enable control to enable/disable the device. When the regulator is in shutdown state, the shutdown current consumes as low as 0.22µA (TYP).

### Input Capacitor Selection (C<sub>IN</sub>)

The input decoupling capacitor should be placed as close as possible to the IN pin to ensure the device stability. 1µF or larger X7R or X5R ceramic capacitor is selected to get good dynamic performance.

When V<sub>IN</sub> is required to provide large current instantaneously, a large effective input capacitor is required. Multiple input capacitors can limit the input tracking inductance. Adding more input capacitors is available to restrict the ringing and to keep it below the device absolute maximum ratings. For C<sub>OUT</sub> with larger capacitance, it is recommended to choose the larger capacitance C<sub>IN</sub>.

### Output Capacitor Selection (C<sub>OUT</sub>)

One or more output capacitors are required to maintain the stability of the LDO, and the output capacitors should be placed as close as possible to the OUT pin. In addition, in order to obtain the best transient performance, it is recommended to use X7R and X5R ceramic capacitors as output capacitors. Ceramic capacitors have low equivalent series resistance (ESR), excellent temperature and DC bias characteristics. However, it cannot be ignored that the effective capacitance of ceramic capacitors is affected by temperature, DC bias and package size.

For example, Figure 4 shows the capacitance and DC bias and temperature characteristics of 0805, 10V, 10µF±10%, X7R capacitor. Therefore, it is necessary to evaluate whether the effective capacitance of the output capacitor can meet the stability requirements of the LDO in practical applications. In general, a capacitor in higher voltage rating and a larger package exhibits better stability, and the effective capacitance can be obtained from the manufacturer datasheet.

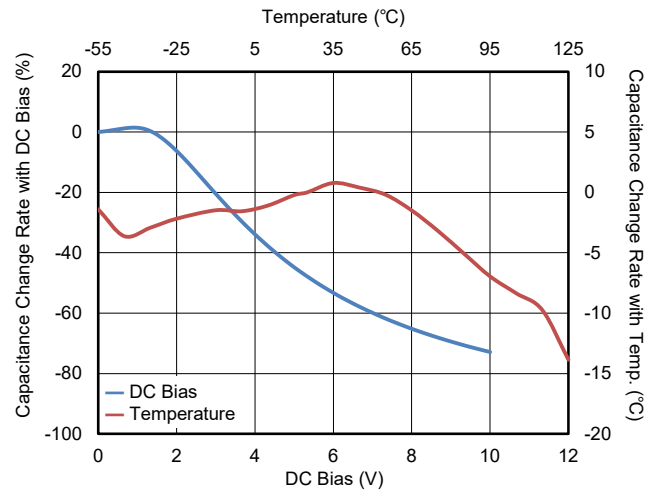

Figure 4. Capacitance vs. DC Bias and Temperature Characteristics

The SGM2084xQ requires a minimum effective capacitance of 0.5µF for C<sub>OUT</sub> to ensure stability. Additionally, C<sub>OUT</sub> with larger capacitance and lower ESR will help increase the high frequency PSRR and improve the load transient response.

### Adjustable Regulator

The output voltage of the SGM2084-ADJQ can be adjusted from 0.55V to 5.0V. The FB pin will be connected to two external resistors as shown in Figure 5. The output voltage is determined by the following equation:

$$V_{OUT} = V_{FB} \times \left( 1 + \frac{R_1}{R_2} \right) \quad (1)$$

where:

V<sub>OUT</sub> is output voltage and V<sub>FB</sub> is the internal voltage reference, V<sub>FB</sub> = 0.55V.

One parallel capacitor (C<sub>FF</sub>) with R<sub>1</sub> can be used to improve the PSRR, increase the transient response and reduce the output noise. The resistance range of R<sub>2</sub> is recommended to be between 5kΩ and 130kΩ.

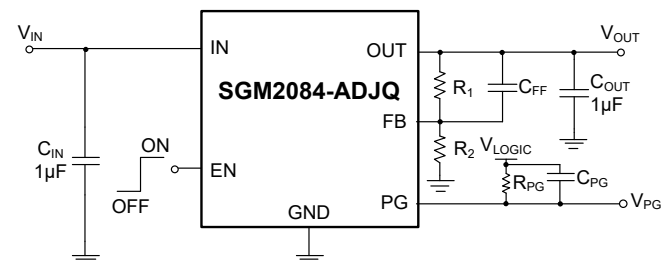

Figure 5. Adjustable Output Voltage Application

# Automotive 1A, Fast Transient Response, SGM2084xQ Low Noise and High Accuracy LDO with Power-Good

## APPLICATION INFORMATION (continued)

### Enable Operation

The SGM2084xQ uses the EN pin to enable/disable the device and to deactivate/activate the output automatic discharge function.

When the EN pin voltage is lower than 0.4V, the device is in shutdown state. There is no current flowing from IN to OUT pins. In this state, the automatic discharge transistor is active to discharge the output voltage through a 100Ω (TYP) resistor and the PG output is pulled down.

When the EN pin voltage is higher than 1.0V, the device is in active state. The output voltage is regulated to the expected value and the automatic discharge transistor is turned off.

### Under-Voltage Lockout (UVLO)

The UVLO circuit monitors the input voltage to prevent the device from turning on before  $V_{IN}$  rises above the  $V_{UVLO}$  threshold. The UVLO circuit responds quickly to glitches on the IN pin and attempts to disable the output of the device if any of these rails collapses. The local input capacitance prevents severe brownouts in most applications. When the SGM2084xQ enters UVLO, the PG output is pulled down.

### Power-Good Function

The SGM2084xQ features PG function for monitoring the feedback voltage, so as to reflect the state of the output voltage. When the output voltage is lower than  $PG_{LTH}$ , the PG pin open-drain engages and pulls the PG pin close to GND. When the output voltage is higher than  $PG_{HTH}$ , the PG pin is indicated as high impedance. Connecting the PG pin to an external power supply via a pull-up resistor enables any downstream device to receive a power-good valid logic signal for sequencing. The resistance range of the pull-up resistor is recommended to be between 10kΩ and 100kΩ.

When an external feed-forward capacitor ( $C_{FF}$ ) is added in application, the total LDO startup time constant increases by approximately  $3 \times R_1 \times C_{FF}$ .

If the Power-Good (PG) output time constant remains unchanged, the PG signal may not accurately indicate whether  $V_{OUT}$  has reached the expected voltage. To ensure a valid PG output, the following design configurations must be implemented to match the time constants.

Add a PG delay capacitor ( $C_{PG}$ ) and connect  $C_{PG}$  in parallel with the PG pull-up resistor ( $R_{PG}$ ) refer to Figure 5. Ensure the following condition is met:

$$3 \times R_{PG} \times C_{PG} \geq 3 \times R_1 \times C_{FF} \quad (2)$$

Figure 6 shows the differences in PG signals when  $C_{FF}$  and  $C_{PG}$  are added. In Figure 6,  $t_{REF}$  is the time that takes for the  $V_{FB}$  voltage to rise from 0V to  $92\% \times V_{REF}$ ,  $t_{CFF}$  is the startup time contributed by  $C_{FF}$ .

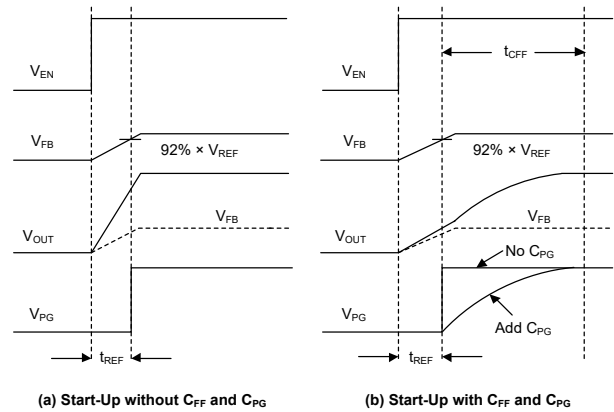

**Figure 6. Typical Power-Good Timing Diagram**

The PG output is pulled down when the SGM2084xQ is in one of the following states, including disabled, thermal shutdown and UVLO.

### Output Current Limit Protection

When overload events happen, the output current is internally limited to 1.9A (TYP). When the OUT pin is shorted to ground, the output current is internally limited to 555mA (TYP).

### Thermal Shutdown

When the die temperature exceeds the threshold value of thermal shutdown, the SGM2084xQ will be in shutdown state and it will remain in this state until the die temperature decreases to +145°C. When the device enters thermal shutdown, the PG output is pulled low.

### Power Dissipation ( $P_D$ )

Power dissipation ( $P_D$ ) of the SGM2084xQ can be calculated by the equation  $P_D = (V_{IN} - V_{OUT}) \times I_{OUT}$ . The maximum allowable power dissipation ( $P_{D(MAX)}$ ) of the SGM2084xQ is affected by many factors, including the difference between junction temperature and ambient temperature ( $T_{J(MAX)} - T_A$ ), package thermal resistance from the junction to the ambient environment ( $\theta_{JA}$ ), the rate of ambient airflow and PCB layout.  $P_{D(MAX)}$  can be approximated by the following equation:

$$P_{D(MAX)} = (T_{J(MAX)} - T_A) / \theta_{JA} \quad (3)$$

# SGM2084xQ Automotive 1A, Fast Transient Response, Low Noise and High Accuracy LDO with Power-Good

---

## REVISION HISTORY

NOTE: Page numbers for previous revisions may differ from page numbers in the current version.

<b>MAY 2026 – REV.A to REV.A.1</b>	<b>Page</b>
Update Electrical Characteristics section .....	7

---

<b>Changes from Original to REV.A (JUNE 2025)</b>	<b>Page</b>
Changed from product preview to production data.....	All

---

# PACKAGE INFORMATION

## PACKAGE OUTLINE DIMENSIONS

### TDFN-2x2-6DL

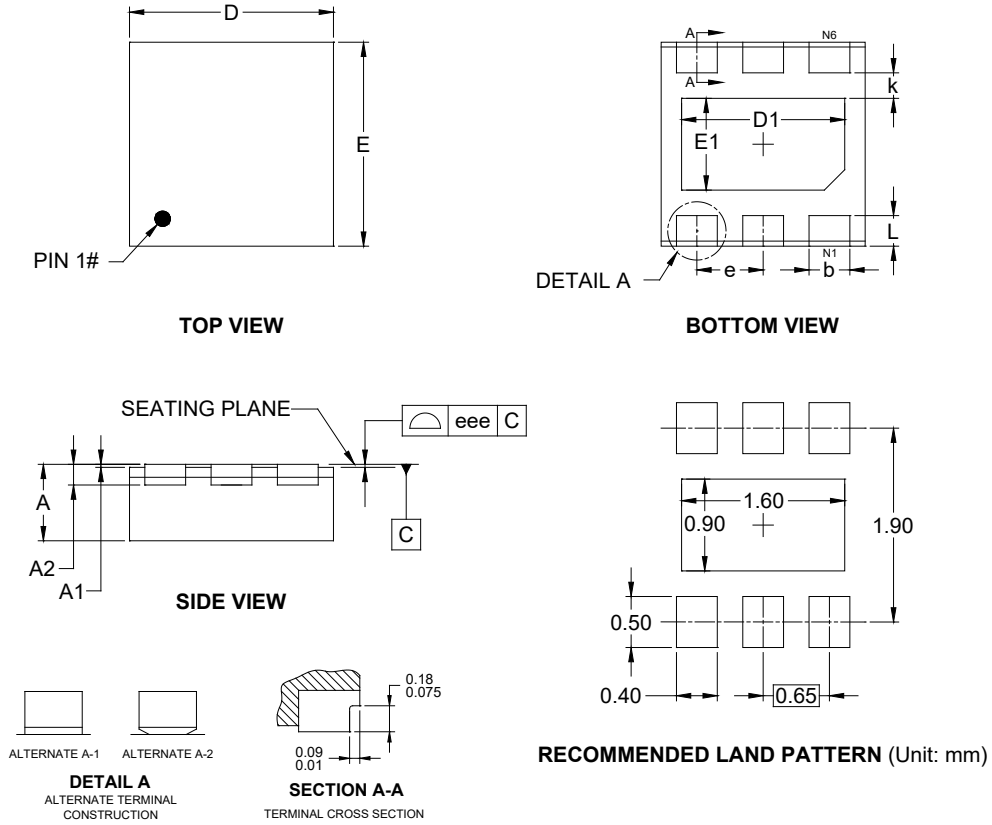

Symbol	Dimensions In Millimeters		
	MIN	NOM	MAX
A	0.700	-	0.800
A1	0.000	-	0.050
A2	0.203 REF		
b	0.350	-	0.450
D	1.900	-	2.100
E	1.900	-	2.100
D1	1.500	-	1.700
E1	0.800	-	1.000
e	0.650 BSC		
L	0.250	-	0.350
k	0.250 REF		
eee	0.080		

NOTE: This drawing is subject to change without notice.

# PACKAGE INFORMATION

## PACKAGE OUTLINE DIMENSIONS

### TDFN-3x3-8KL

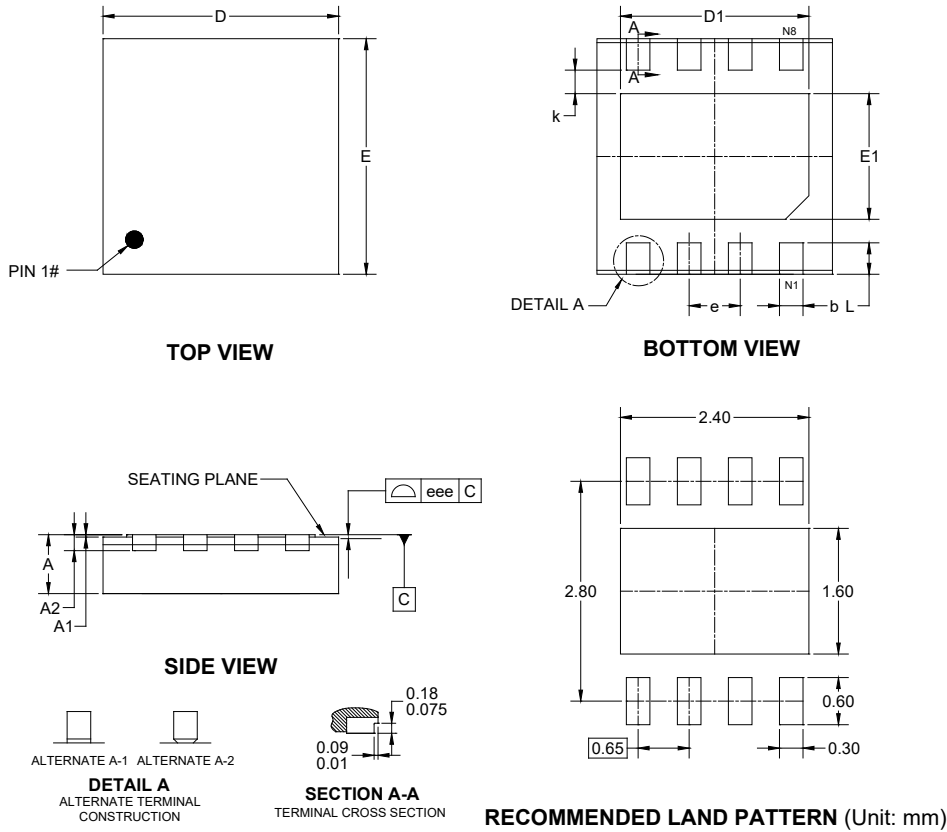

Symbol	Dimensions In Millimeters		
	MIN	NOM	MAX
A	0.700	-	0.800
A1	0.000	-	0.050
A2	0.203 REF		
b	0.250	-	0.350
D	2.900	-	3.100
D1	2.300	-	2.500
E	2.900	-	3.100
E1	1.500	-	1.700
e	0.650 BSC		
k	0.300 REF		
L	0.300	-	0.500
eee	0.080		

NOTE: This drawing is subject to change without notice.

## TAPE AND REEL INFORMATION

### REEL DIMENSIONS

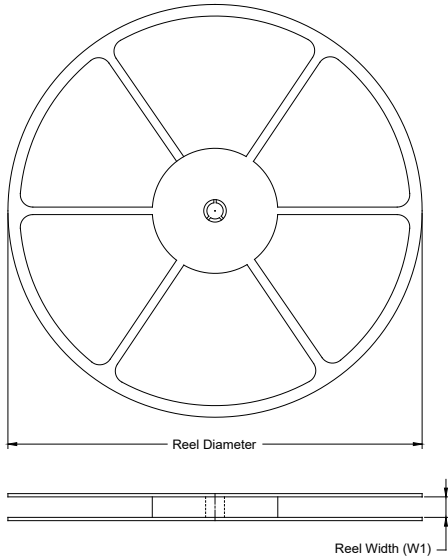

### TAPE DIMENSIONS

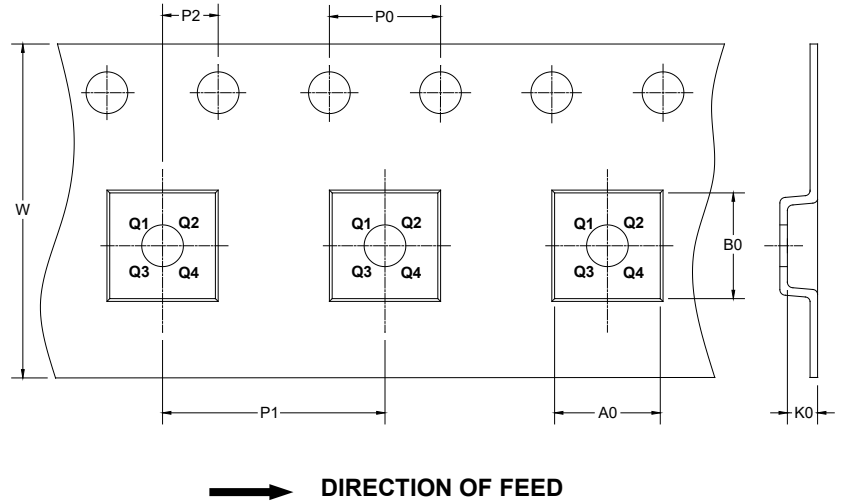

NOTE: The picture is only for reference. Please make the object as the standard.

### KEY PARAMETER LIST OF TAPE AND REEL

Package Type	Reel Diameter	Reel Width W1 (mm)	A0 (mm)	B0 (mm)	K0 (mm)	P0 (mm)	P1 (mm)	P2 (mm)	W (mm)	Pin1 Quadrant
TDFN-2×2-6DL	7"	9.5	2.30	2.30	1.10	4.0	4.0	2.0	8.0	Q2
TDFN-3×3-8KL	13"	12.4	3.35	3.35	1.13	4.0	8.0	2.0	12.0	Q2

DD0001

# PACKAGE INFORMATION

## CARTON BOX DIMENSIONS

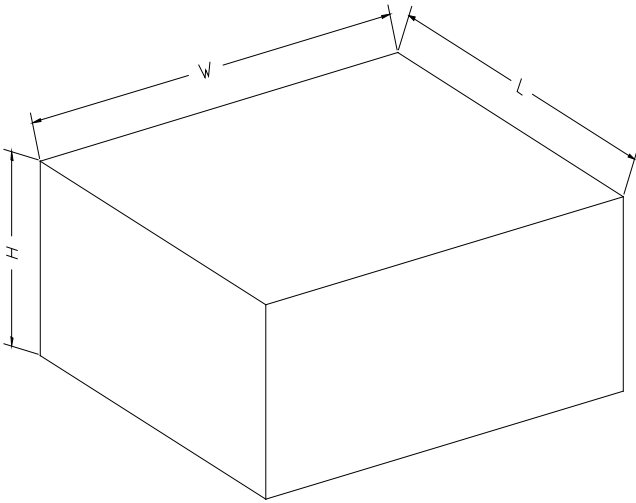

NOTE: The picture is only for reference. Please make the object as the standard.

## KEY PARAMETER LIST OF CARTON BOX

Reel Type	Length (mm)	Width (mm)	Height (mm)	Pizza/Carton
7" (Option)	368	227	224	8
7"	442	410	224	18
13"	386	280	370	5

DD0002