

FEATURES

- GaN-on-Silicon E-Mode HEMT Technology
- Industry Application
- Very Low Gate Charge
- Ultra-Low On-Resistance
- Very Small Footprint
- RoHS Compliant and Halogen Free

APPLICATIONS

High Frequency DC/DC Converter
 High Density DC/DC Power Module
 Synchronous Rectification
 Motor Driver
 Solar System MPPT

ABSOLUTE MAXIMUM RATINGS

PARAMETER	SYMBOL	VALUE	UNITS	
Drain-to-Source Voltage	V_{DS}	100	V	
Drain-to-Source Voltage ⁽¹⁾ ($V_{GS} = 0V$, 1h total time, $T_A = T_{JMAX}$)	V_{DS_TR}	120		
Gate-to-Source Voltage	V_{GS}	6	V	
		-4		
Gate-to-Source Voltage ⁽¹⁾ ($V_{DS} = 0V$, 168h total time, $T_A = T_{JMAX}$)	V_{GS_TR}	6.5		
Drain Current	I_D	$T_C = +25^\circ C$	477	A
		$T_A = +25^\circ C$	34	
Drain Current (Pulse) ⁽²⁾	I_{DM}	980		
Total Dissipation	P_D	$T_C = +25^\circ C$	655	W
		$T_A = +25^\circ C$	3.2	
Junction Temperature	T_J	-40 to +150	$^\circ C$	
Storage Temperature Range	T_{STG}	-40 to +150	$^\circ C$	
Lead Temperature (Soldering, 10s)		+260	$^\circ C$	

Stresses beyond those listed in Absolute Maximum Ratings may cause permanent damage to the device. Exposure to absolute maximum rating conditions for extended periods may affect reliability.

NOTES:

1. Provided as measure of robustness under abnormal operating conditions and not recommended for normal operation.
2. $V_{GS} = 5V$, $T_J = +25^\circ C$, $t_{PULSE} = 100\mu s$.

PRODUCT SUMMARY

$R_{DS(on)}$ (TYP) $V_{GS} = 5V$	$R_{DS(on)}$ (MAX) $V_{GS} = 5V$	I_D (MAX) $T_C = +25^\circ C$
1.1m Ω	1.5m Ω	477A

PIN CONFIGURATION

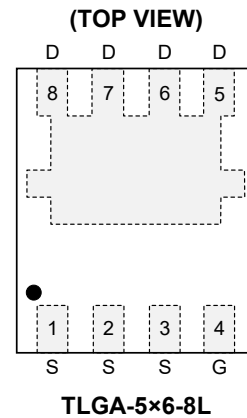

EQUIVALENT CIRCUIT

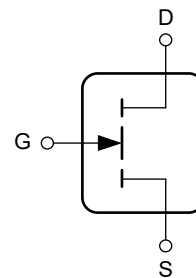

PACKAGE/ORDERING INFORMATION

MODEL	PACKAGE DESCRIPTION	SPECIFIED TEMPERATURE RANGE	ORDERING NUMBER	PACKAGE MARKING	PACKING OPTION
SGMGQ11410	TLGA-5x6-8L	-40°C to +150°C	SGMGQ11410TTLBI8G/TR	11410 TLBI8 XXXXX	Tape and Reel, 2500

MARKING INFORMATION

NOTE: XXXXX = Date Code, Trace Code and Vendor Code.

XXXXX

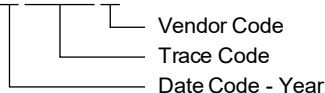

Green (RoHS & HSF): SG Micro Corp defines "Green" to mean Pb-Free (RoHS compatible) and free of halogen substances. If you have additional comments or questions, please contact your SGMICRO representative directly.

DISCLAIMER

SG Micro Corp reserves the right to make any change in circuit design, or specifications without prior notice.

THERMAL RESISTANCE

PARAMETER	SYMBOL	TYP	UNITS
Junction-to-Ambient Thermal Resistance ⁽¹⁾	R _{θJA}	38	°C/W
Junction-to-Board Thermal Resistance	R _{θJB}	2.1	°C/W
Junction-to-Case Thermal Resistance	R _{θJC}	0.2	°C/W

NOTE: 1. R_{θJA} is determined with the device on FR4 PCB (2s2p with thermal vias) defined in accordance with JEDEC standards. PCB is mounted in horizontal position without air stream cooling.

ELECTRICAL CHARACTERISTICS(T_J = +25°C, unless otherwise noted.)

PARAMETER	SYMBOL	CONDITIONS	MIN	TYP	MAX	UNITS
Static Characteristics						
Zero Gate Voltage Drain Current	I _{DSS}	V _{GS} = 0V, V _{DS} = 100V	T _J = +25°C	2.5	200	μA
			T _J = +125°C	500		
Gate-to-Source Leakage Current	I _{GSS}	V _{GS} = 6V		2	200	μA
		V _{GS} = 6V, T _J = +125°C		50		
		V _{GS} = -4V		0.1	200	
Gate-to-Source Threshold Voltage	V _{GS_TH}	V _{GS} = V _{DS} , I _D = 19mA	0.9	1.1	2.1	V
Drain-to-Source On-State Resistance	R _{DSON}	V _{GS} = 5V, I _D = 2.5A		1.1	1.5	mΩ
Gate Resistance	R _G	f = 5MHz, open drain		2		Ω
Source-to-Drain Forward Voltage	V _{SD}	V _{GS} = 0V, I _S = 50A		2		V
Dynamic Characteristics						
Input Capacitance	C _{ISS}	V _{GS} = 0V, V _{DS} = 50V		3705		pF
Output Capacitance	C _{OSS}			1083		
Reverse Transfer Capacitance	C _{RSS}			16		
Effective Output Capacitance, Energy Related	C _{O_ER}	V _{GS} = 0V, V _{DS} = 0V to 50V		1480		
Effective Output Capacitance, Time Related	C _{O_TR}			2030		
Total Gate Charge	Q _G	V _{GS} = 5V, V _{DS} = 0V to 50V, I _D = 50A		25.1		nC
Gate-to-Source Charge	Q _{GS}			7.5		
Gate-to-Drain Charge	Q _{GD}			3		
Gate Plateau Voltage	V _{PLAT}	V _{GS} = 0V to 5V, V _{DS} = 50V, I _D = 50A		2		V
Gate Charge at Threshold	Q _{G_TH}	V _{GS} = 5V, V _{DS} = 0V to 50V, I _D = 50A		4.5		nC
Output Charge	Q _{OSS}	V _{GS} = 0V, V _{DS} = 0V to 50V		102		
Reverse Recovery Charge	Q _{RR}	V _{DS} = 50V, I _S = 50A		0		

TYPICAL PERFORMANCE CHARACTERISTICS

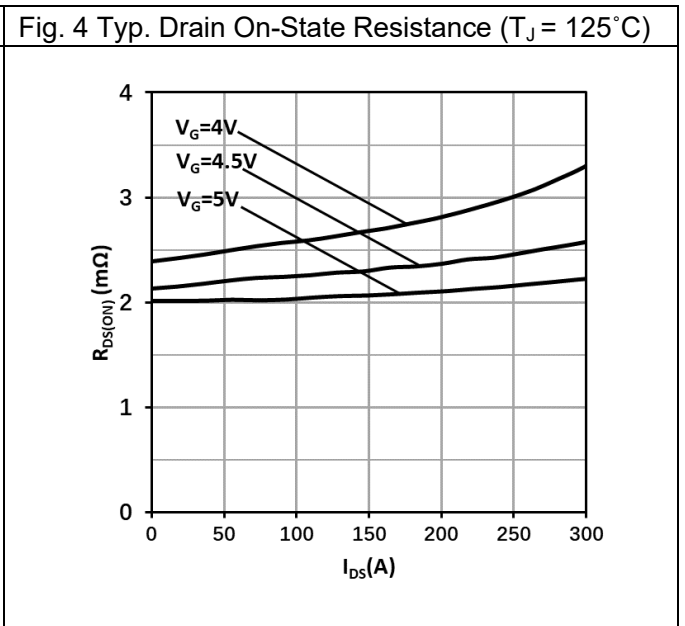
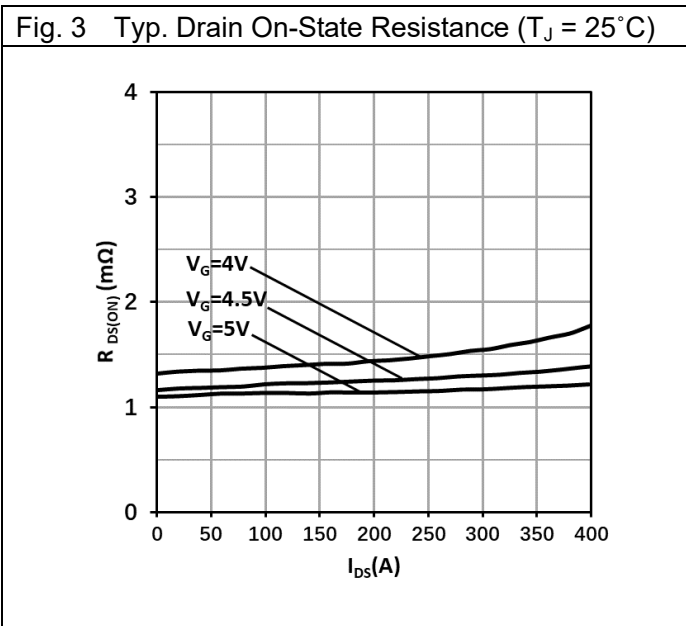
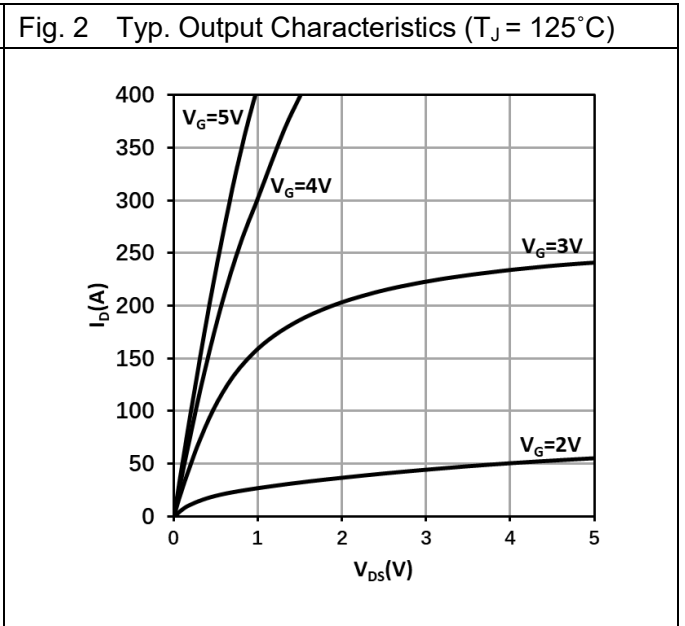
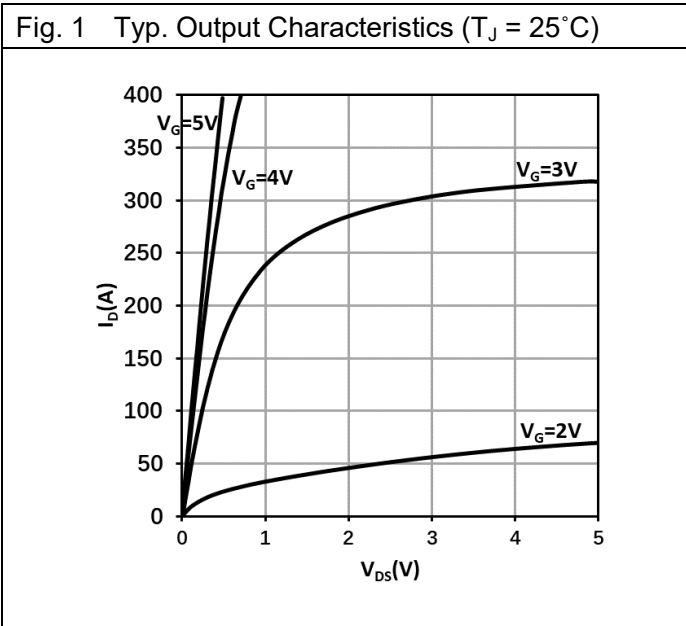

TYPICAL PERFORMANCE CHARACTERISTICS (continued)

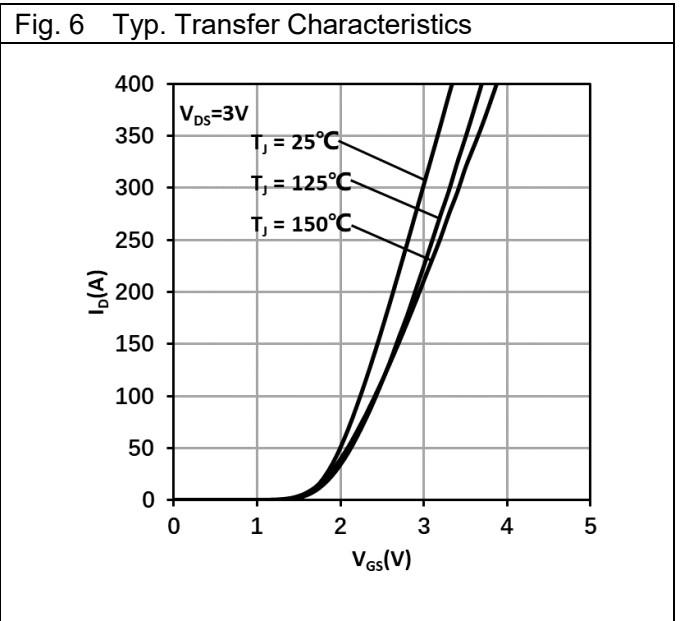
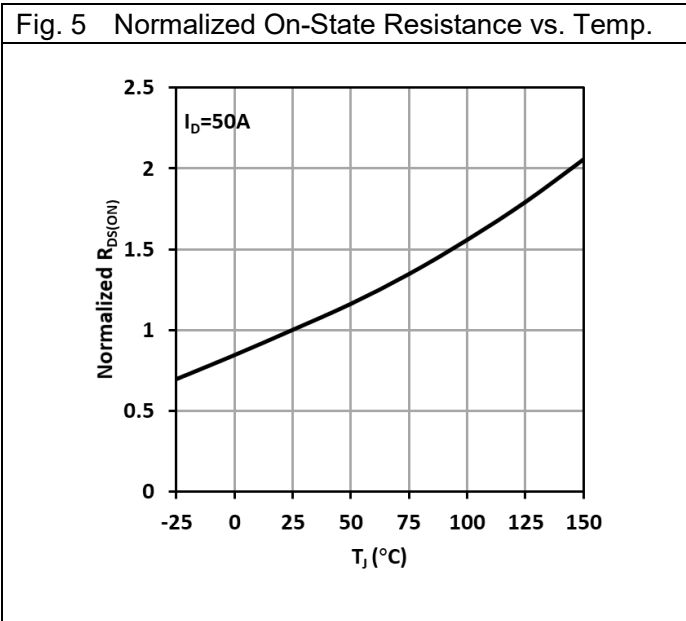

Fig. 7 Typ. Reverse Drain-to-Source Characteristics ($V_{GS} \leq 0, T_J = 25^\circ\text{C}$)

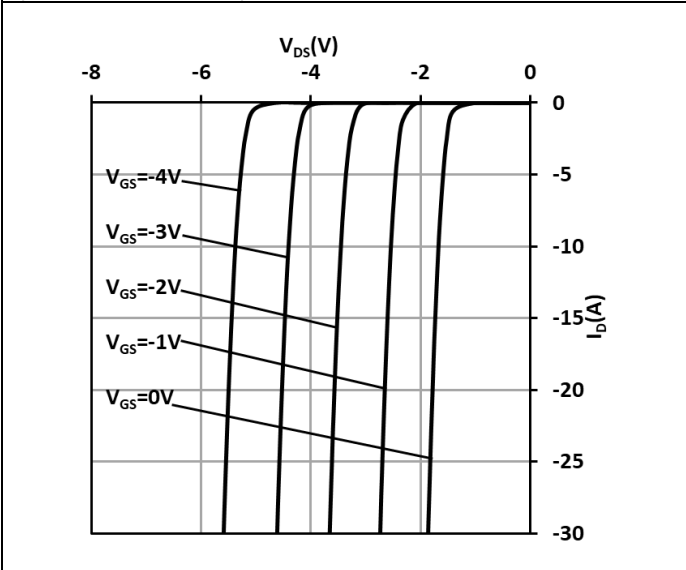
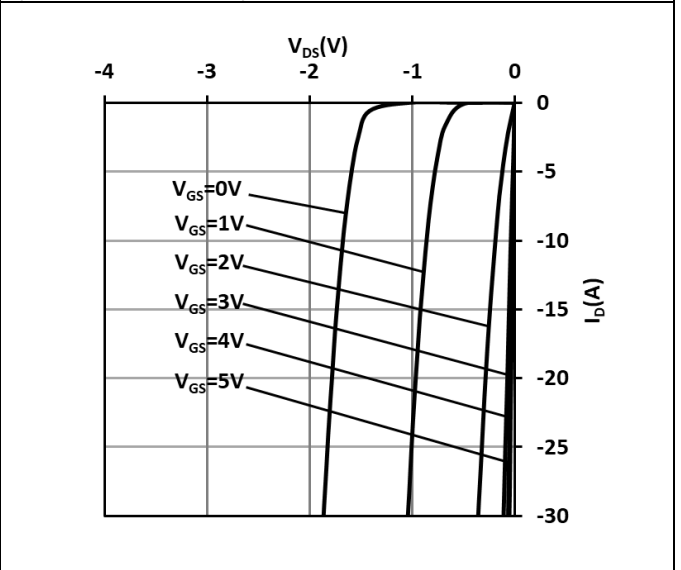

Fig. 8 Typ. Reverse Drain-to-Source Characteristics ($V_{GS} \geq 0, T_J = 25^\circ\text{C}$)



TYPICAL PERFORMANCE CHARACTERISTICS (continued)

Fig. 9 Typ. Reverse Drain-to-Source Characteristics ($V_{GS} \leq 0, T_J = 125^\circ\text{C}$)

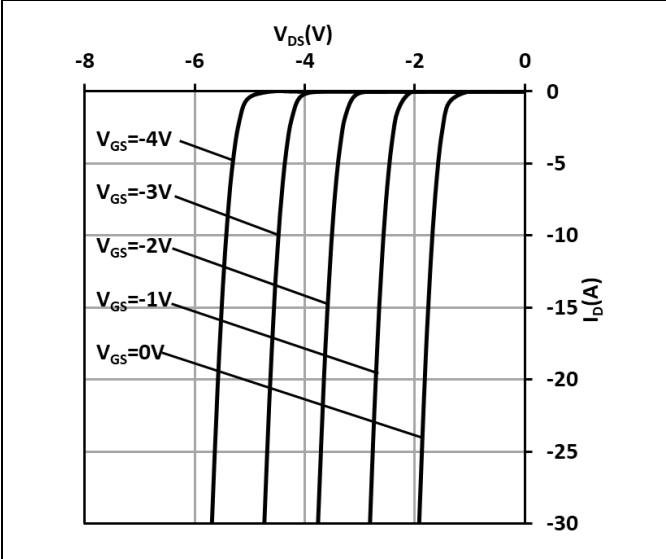

Fig. 10 Typ. Reverse Drain-to-Source Characteristics ($V_{GS} \geq 0, T_J = 125^\circ\text{C}$)

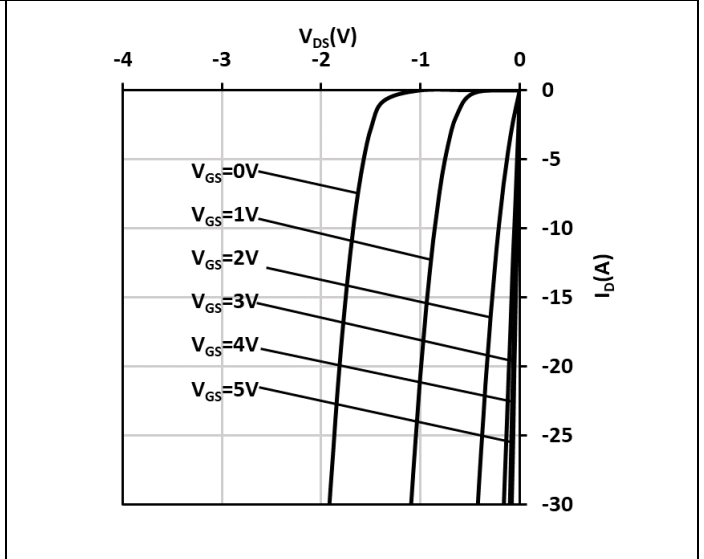

Fig. 11 Typ. Capacitances Characteristics

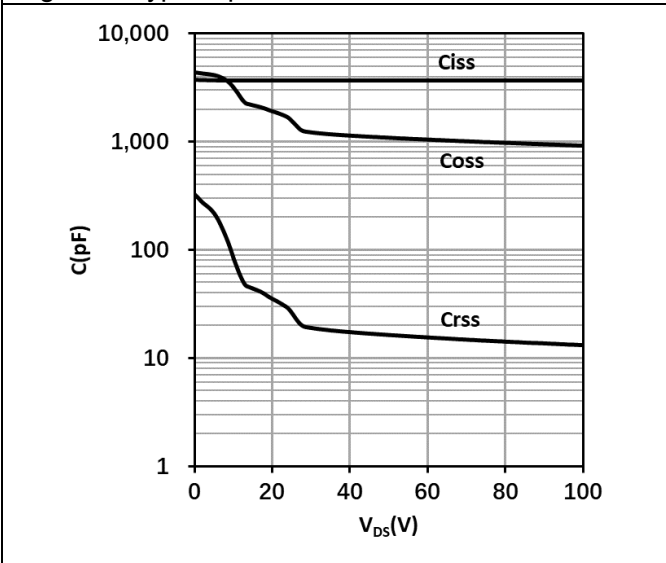
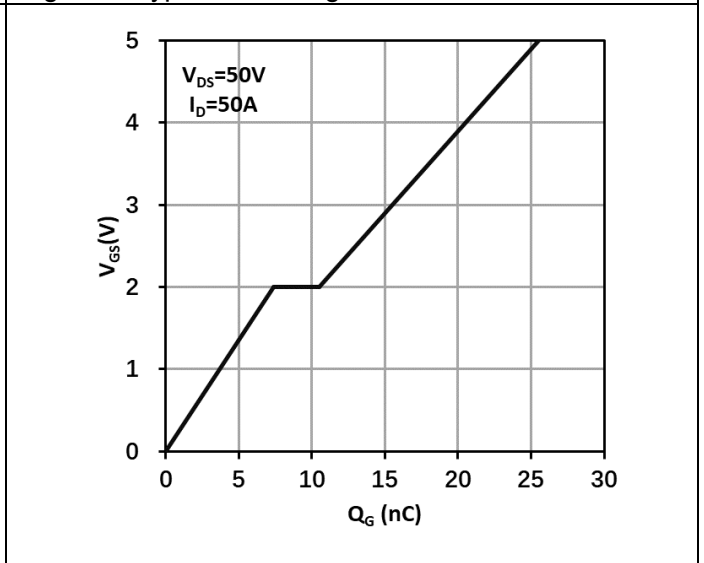

Fig. 12 Typ. Gate Charge



TYPICAL PERFORMANCE CHARACTERISTICS (continued)

Fig. 13 Normalized Threshold Voltage vs. Temp.

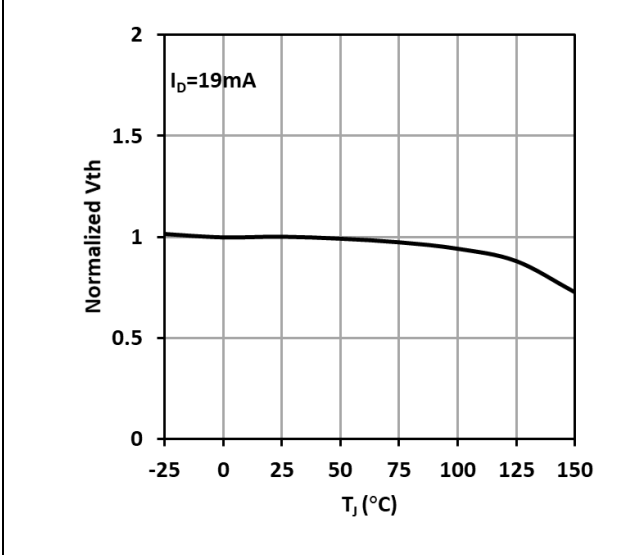

Fig. 14 Typ. Output Charge

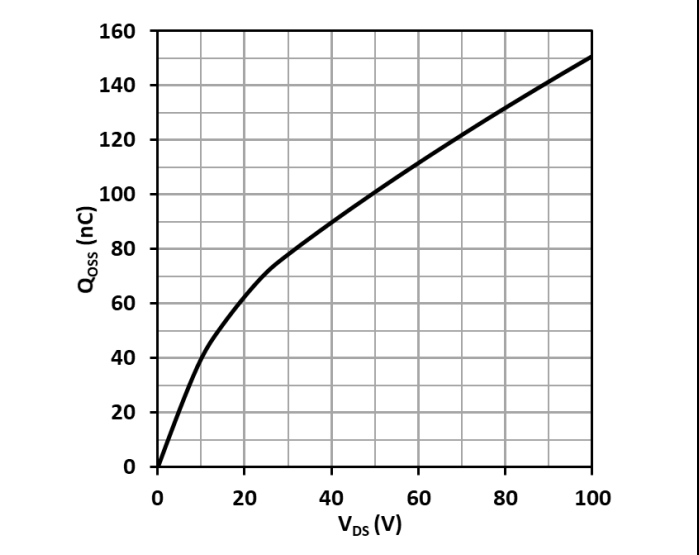

Fig. 15 Typ. Output Capacitance Stored Energy

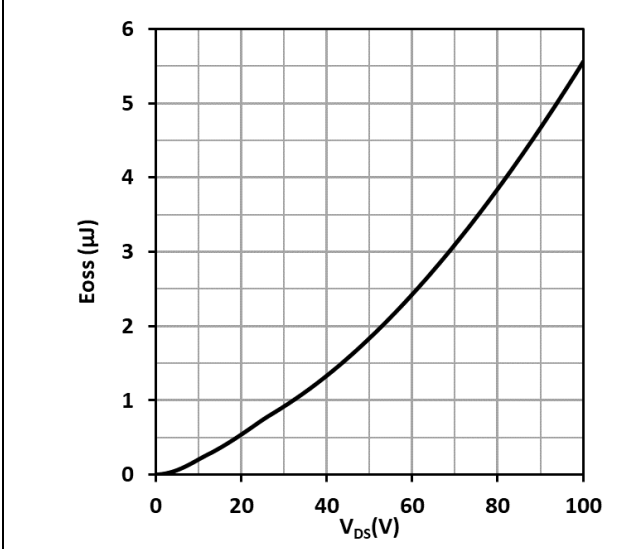
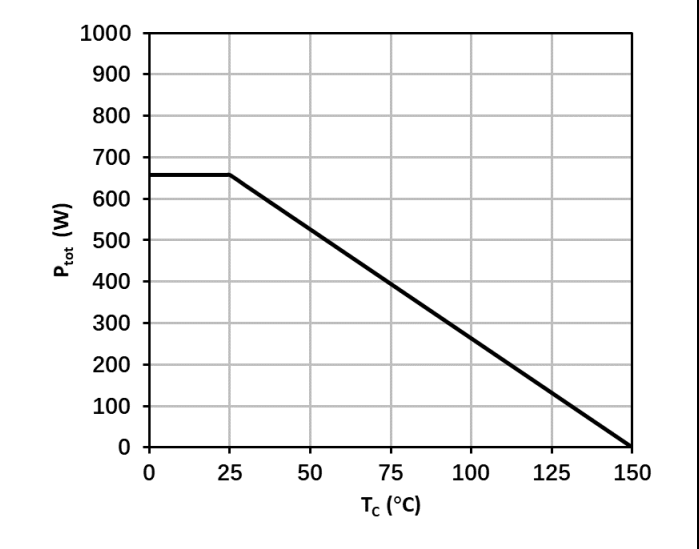

Fig. 16 Power Dissipation P_{tot} = f(T_C), R_{θJC} = 0.2°C/W



TYPICAL PERFORMANCE CHARACTERISTICS (continued)

Fig. 17 Power Dissipation $P_{tot} = f(T_A), R_{\theta JA} = 38^\circ\text{C/W}$

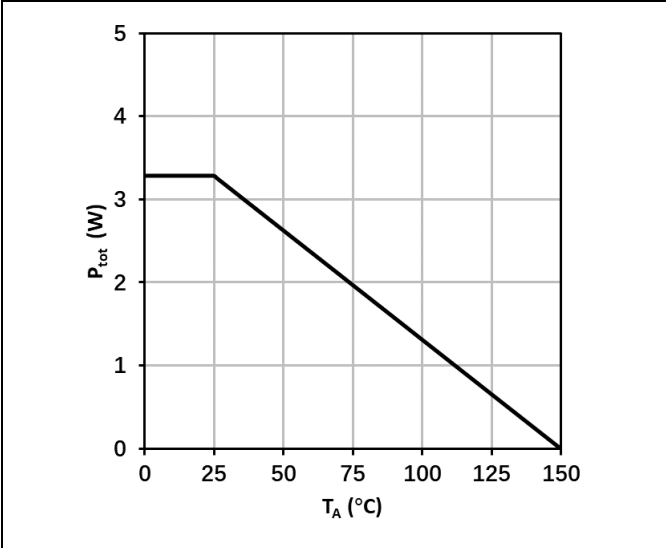

Fig. 18 Typ. Gate-to-Source Leakage Characteristics $I_G = f(V_{GS});$ Drain Open

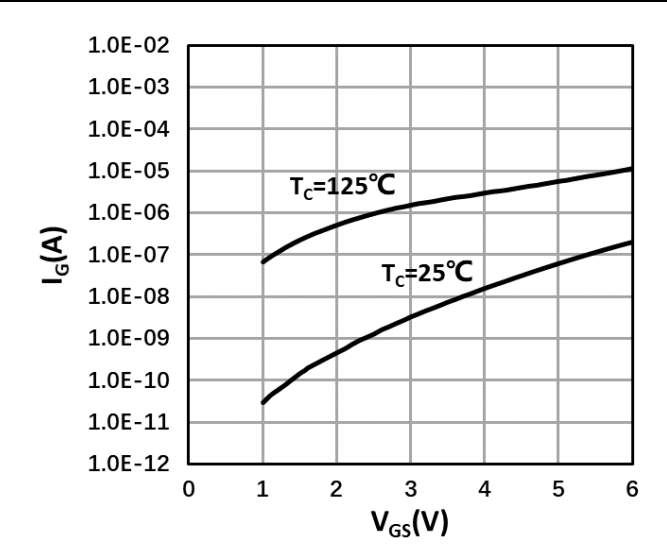

Fig. 19 Typ. Drain-Source Leakage Characteristics $I_{DSS} = f(V_{DS}); V_{GS} = 0\text{V}$

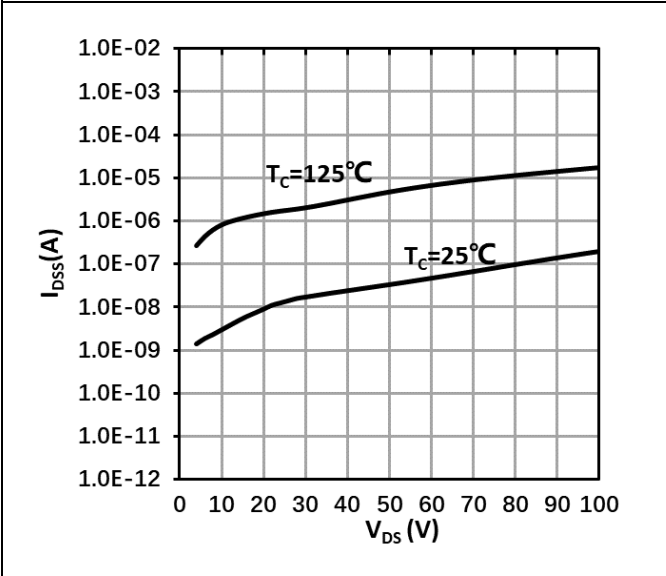
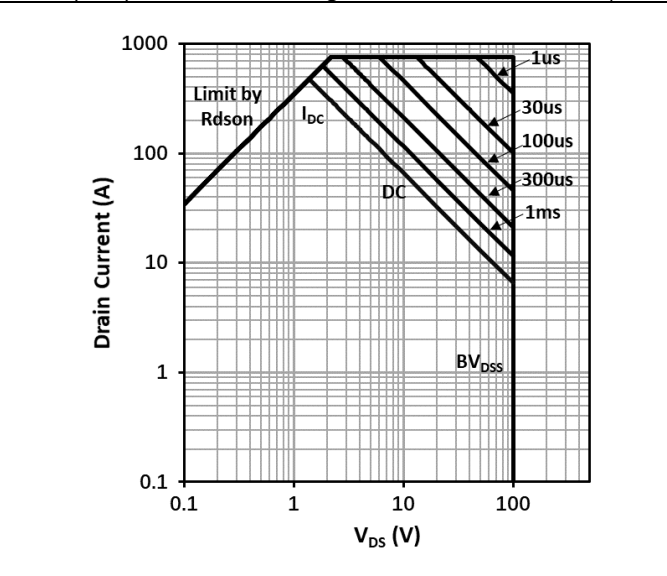

Fig. 20 Safe Operating Area $I_D = f(V_{DS}); T_c = 25^\circ\text{C};$ Single Pulse; Parameter: t_p



TYPICAL PERFORMANCE CHARACTERISTICS (continued)

Fig. 21 Safe Operating Area
 $I_D = f(V_{DS})$; $T_C = 125^\circ\text{C}$; Single Pulse; Parameter: t_p

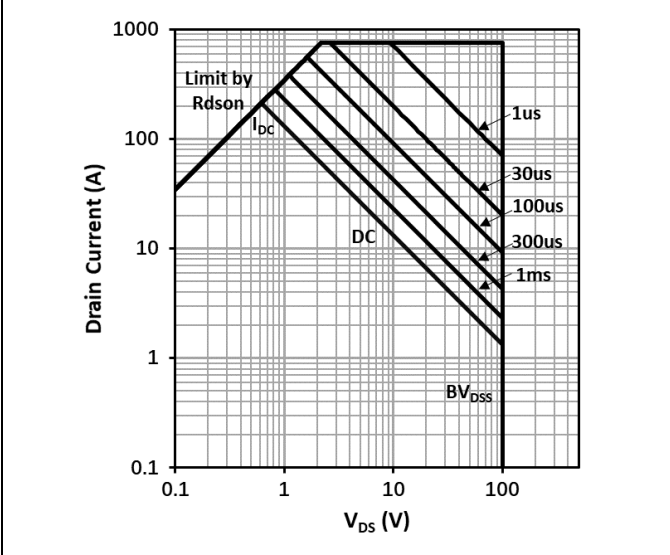
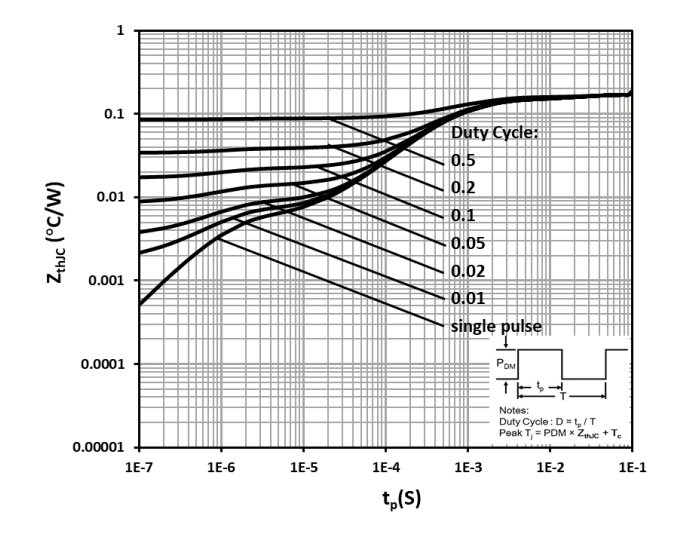

Fig. 22 Max. Transient Thermal Impedance
 $Z_{thJC} = f(t_p)$; Parameter: $D = t_p/T$



REVISION HISTORY

NOTE: Page numbers for previous revisions may differ from page numbers in the current version.

Changes from Original to REV.A (JUNE 2026)	Page
Changed from product preview to production data.....	All

PACKAGE OUTLINE DIMENSIONS

TLGA-5x6-8L

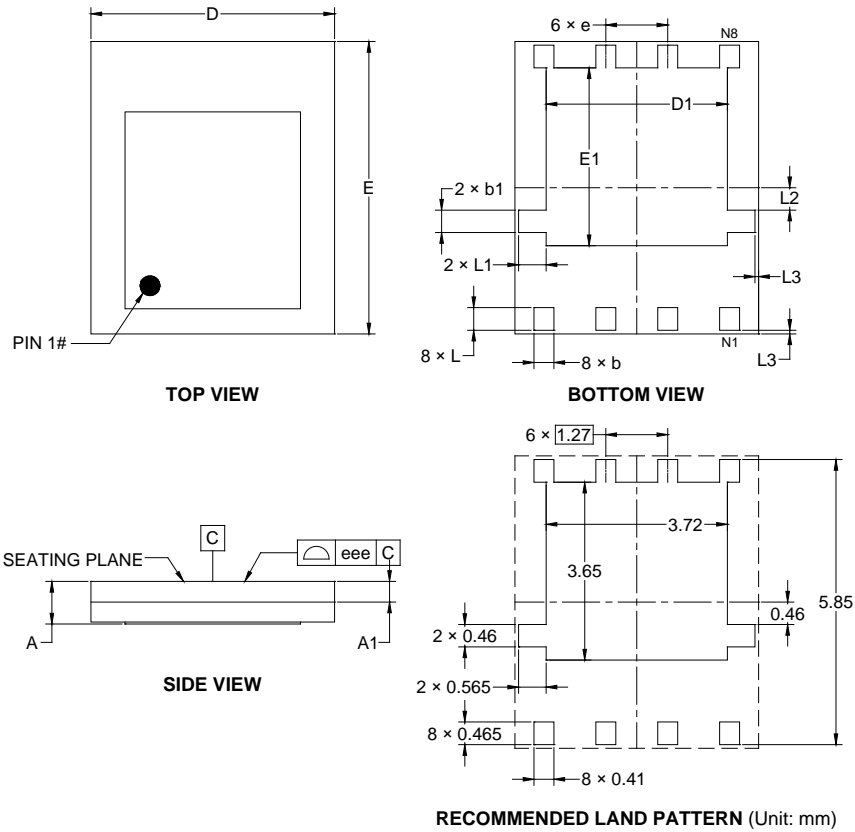

Symbol	Dimensions In Millimeters		
	MIN	NOM	MAX
A	0.774	-	0.974
A1	0.424 REF		
b	0.360	-	0.460
b1	0.410	-	0.510
D	4.900	-	5.100
D1	3.620	-	3.820
E	5.900	-	6.100
E1	3.550	-	3.750
e	1.270 BSC		
e1	0.460 BSC		
L	0.415	-	0.515
L1	0.515	-	0.615
L2	0.460 REF		
L3	0.075 REF		
eee	0.100		

NOTE: This drawing is subject to change without notice.

TAPE AND REEL INFORMATION

REEL DIMENSIONS

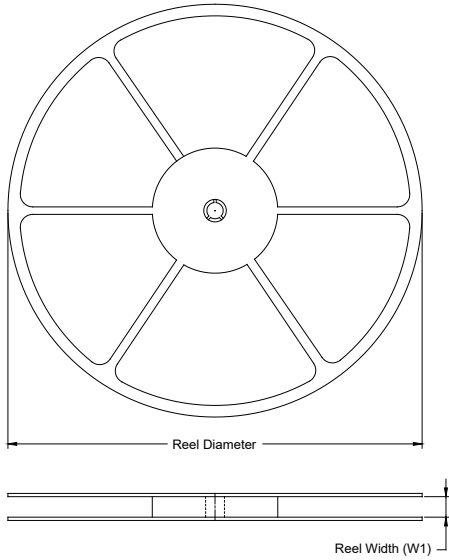

TAPE DIMENSIONS

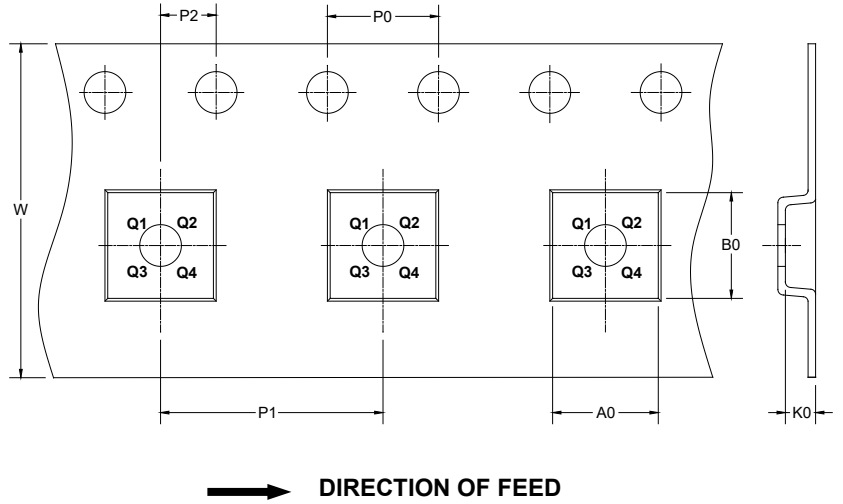

NOTE: The picture is only for reference. Please make the object as the standard.

KEY PARAMETER LIST OF TAPE AND REEL

Package Type	Reel Diameter	Reel Width W1 (mm)	A0 (mm)	B0 (mm)	K0 (mm)	P0 (mm)	P1 (mm)	P2 (mm)	W (mm)	Pin1 Quadrant
TLGA-5×6-8L	13"	12.4	5.30	6.30	1.20	4.0	8.0	2.0	12.0	Q2

DD0001

PACKAGE INFORMATION

CARTON BOX DIMENSIONS

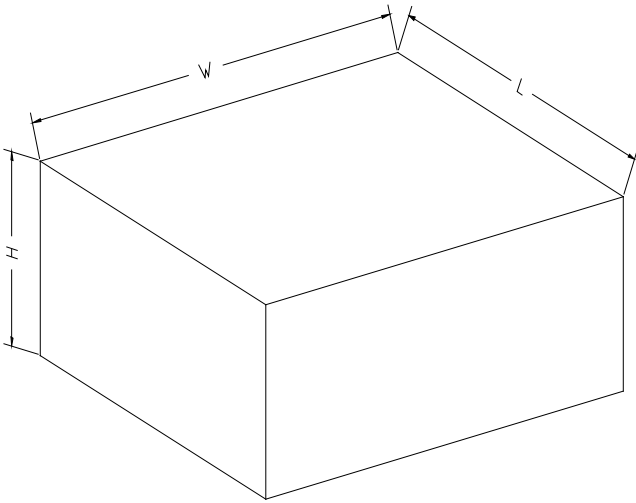

NOTE: The picture is only for reference. Please make the object as the standard.

KEY PARAMETER LIST OF CARTON BOX

Reel Type	Length (mm)	Width (mm)	Height (mm)	Pizza/Carton
13"	386	280	370	5

DD0002