

GENERAL DESCRIPTION

The SGM33685A is a power amplifier (PA) which can support 900MHz to 930MHz. The device uses advanced InGaP/GaAs HBT (heterojunction bipolar transistor) process, so it features high linearity, high efficiency and high ruggedness.

The SGM33685A is available in a Green TQFN-3×3-16L package.

APPLICATIONS

- Repeater
- ISM Band PA
- LTE/WCDMA Femtocell

FEATURES

- **Supply Voltage: 3.3V and 5V**
- **Signal Gain at 5V:**
31dB at 900MHz to 930MHz
- **Signal Gain at 3.3V:**
30.5dB at 900MHz to 930MHz
- **P_{1dB} Output Power at 5V:**
31dBm at 900MHz to 930MHz
- **P_{1dB} Output Power at 3.3V:**
28.5dBm at 900MHz to 930MHz
- **On-Chip 50Ω Matching for Input Port**
- **Available in a Green TQFN-3×3-16L Package**

BLOCK DIAGRAM

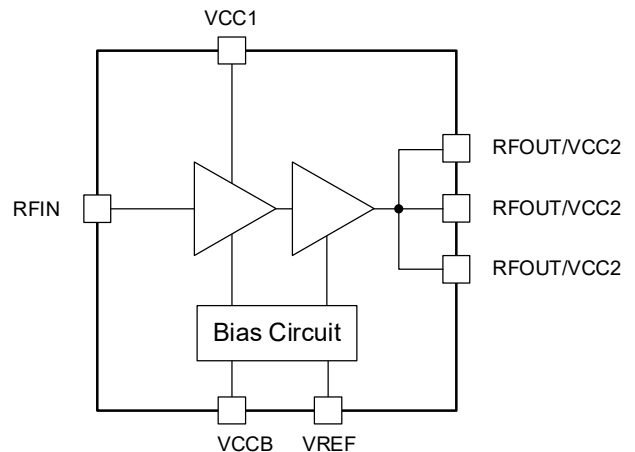

Figure 1. SGM33685A Block Diagram

PACKAGE/ORDERING INFORMATION

MODEL	PACKAGE DESCRIPTION	SPECIFIED TEMPERATURE RANGE	ORDERING NUMBER	PACKAGE MARKING	PACKING OPTION
SGM33685A	TQFN-3x3-16L	-40°C to +105°C	SGM33685AGTQ16G/TR	MEBTQ XXXXX	Tape and Reel, 4000

MARKING INFORMATION

NOTE: XXXXX = Date Code, Trace Code and Vendor Code.

XXXXX

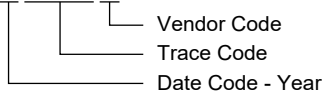

Green (RoHS & HSF): SG Micro Corp defines "Green" to mean Pb-Free (RoHS compatible) and free of halogen substances. If you have additional comments or questions, please contact your SGMICRO representative directly.

ABSOLUTE MAXIMUM RATINGS

- Supply Voltage, V_{CC} 5.5V
- Bias Control Voltage, V_{REF} 3.2V
- RFIN, Under 50Ω Output Terminated, P_{IN} 10dBm
- Storage Temperature Range -40°C to +150°C
- Lead Temperature (Soldering, 10s) +260°C
- ESD Susceptibility ⁽¹⁾
- HBM..... ±1000V

NOTE:

1. For human body model (HBM), all pins comply with ANSI/ESDA/JEDEC JS-001 specifications.

RECOMMENDED OPERATING CONDITIONS

- Operating Frequency Range..... 900MHz to 930MHz
- Supply Voltage Range, V_{CC1} , V_{CC2} , V_{CCB} 3.3V to 5.0V
- Bias Control Voltage, V_{REF} 2.5V to 2.9V
- Operating Ambient Temperature Range..... -40°C to +105°C
- Operating Ambient Temperature Range (TX Power > 30dBm)
..... -40°C to +85°C

OVERSTRESS CAUTION

Stresses beyond those listed in Absolute Maximum Ratings may cause permanent damage to the device. Exposure to absolute maximum rating conditions for extended periods may affect reliability. Functional operation of the device at any conditions beyond those indicated in the Recommended Operating Conditions section is not implied.

ESD SENSITIVITY CAUTION

This integrated circuit can be damaged if ESD protections are not considered carefully. SGMICRO recommends that all integrated circuits be handled with appropriate precautions. Failure to observe proper handling and installation procedures can cause damage. ESD damage can range from subtle performance degradation to complete device failure. Precision integrated circuits may be more susceptible to damage because even small parametric changes could cause the device not to meet the published specifications.

DISCLAIMER

SG Micro Corp reserves the right to make any change in circuit design, or specifications without prior notice.

PIN CONFIGURATION

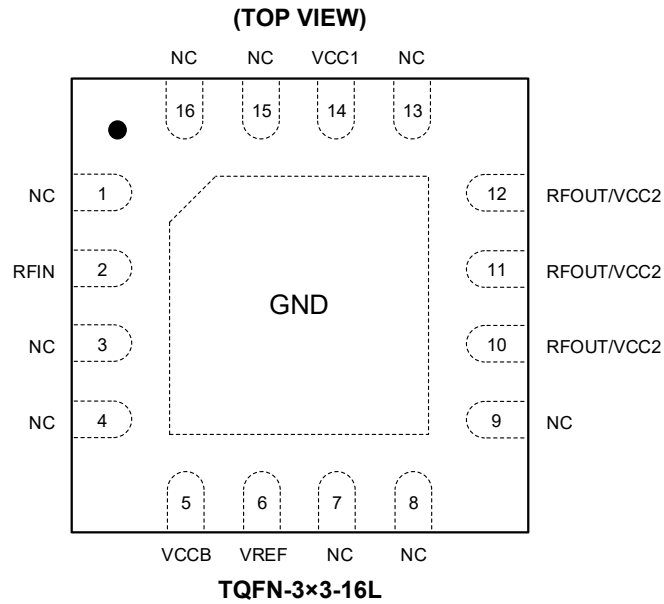

PIN DESCRIPTION

PIN	NAME	FUNCTION
1, 3, 4, 7, 8, 9, 13, 15, 16	NC	No Connection. These pins cannot be connected to ground.
2	RFIN	RF Input.
5	VCCB	Power Supply for Bias Control Circuit.
6	VREF	Bias Control Voltage.
10, 11, 12	RFOUT/VCC2	RF Output and Power Supply for Power Stage-2. These pins are connected internally.
14	VCC1	Power Supply for Power Stage-1.
Exposed Pad	GND	Ground. Exposed pad must be connected to ground.

ELECTRICAL CHARACTERISTICS(T_A = +25°C, 50Ω system with V_{CC1} = V_{CC2} = V_{CCB} = 5V and 3.3V, V_{REF} = 2.8V, unless otherwise noted.)

PARAMETER	SYMBOL	CONDITIONS	MIN	TYP	MAX	UNITS
Characteristics at V_{CC} = 5V						
Frequency Range	f ₀		900	915	930	MHz
Small Signal Gain	G	P _{IN} = -30dBm	29.5	31		dB
1dB Output Compression Point	P _{1dB}	1dB gain compression at 915MHz, CW		31		dBm
Power Added Efficiency	PAE	P _{OUT} = 30dBm		31		%
Current Consumption	I _{CC}	Quiescent (no RF)		115	160	mA
		P _{OUT} = 30dBm		650	790	
Bias Current	I _{REF}	Quiescent (no RF)		3		mA
Input Return Loss	RL _I	P _{IN} = -20dBm		11		dB
Output Return Loss	RL _O	P _{IN} = -20dBm		6		dB
2 nd Harmonics	2f ₀	f ₀ = 915MHz, P _{OUT} = 30dBm		-21		dBm
3 rd Harmonics	3f ₀	f ₀ = 915MHz, P _{OUT} = 30dBm		-36		dBm
Turn On/Off Time	t _S	50% control to 90/10%RF		200	300	ns
Stability	S	Load VSWR = 6:1, all phase angles, RBW = 1MHz, P _{OUT} = 30dBm		-36		dBm
Ruggedness	Ru	No damage or permanent degradation at P _{OUT} = 32dBm, all phases angles		10:1		VSWR
Characteristics at V_{CC} = 3.3V						
Frequency Range	f ₀		900	915	930	MHz
Small Signal Gain	G	P _{IN} = -30dBm	28.5	30.5		dB
1dB Output Compression Point	P _{1dB}	1dB gain compression at 915MHz, CW		28.5		dBm
Power Added Efficiency	PAE	P _{OUT} = 27dBm		33		%
Current Consumption	I _{CC}	Quiescent (no RF)		101	150	mA
		P _{OUT} = 27dBm		458	580	
Bias Current	I _{REF}	Quiescent (no RF)		3		mA
Input Return Loss	RL _I	P _{IN} = -20dBm		11		dB
Output Return Loss	RL _O	P _{IN} = -20dBm		10		dB
2 nd Harmonics	2f ₀	f ₀ = 915MHz, P _{OUT} = 27dBm		-24		dBm
3 rd Harmonics	3f ₀	f ₀ = 915MHz, P _{OUT} = 27dBm		-40		dBm
Turn On/Off Time	t _S	50% control to 90/10%RF		200	300	ns

TYPICAL PERFORMANCE CHARACTERISTICS

T_A = +25°C, 50Ω system with V_{CC1} = V_{CC2} = V_{CCB} = 5V and 3.3V, V_{REF} = 2.8V, unless otherwise noted.

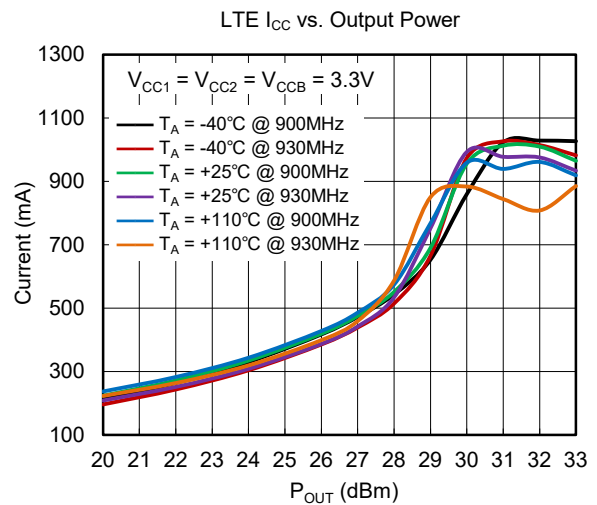
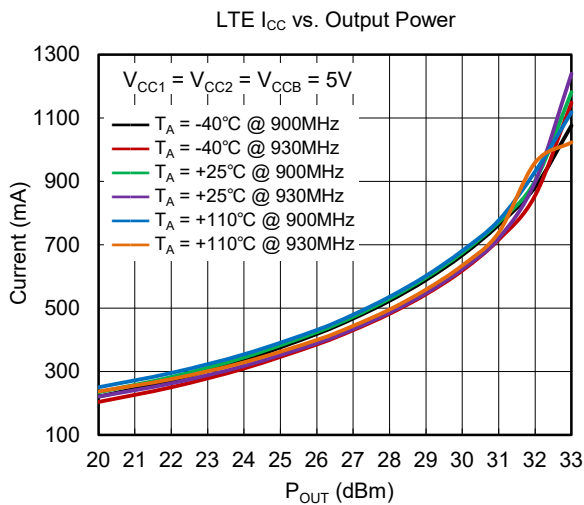
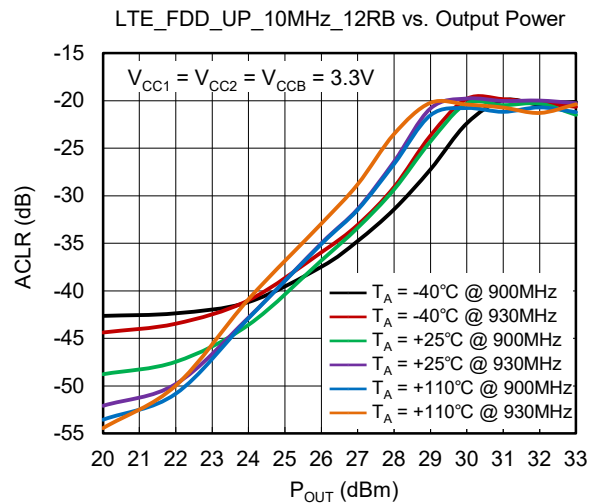
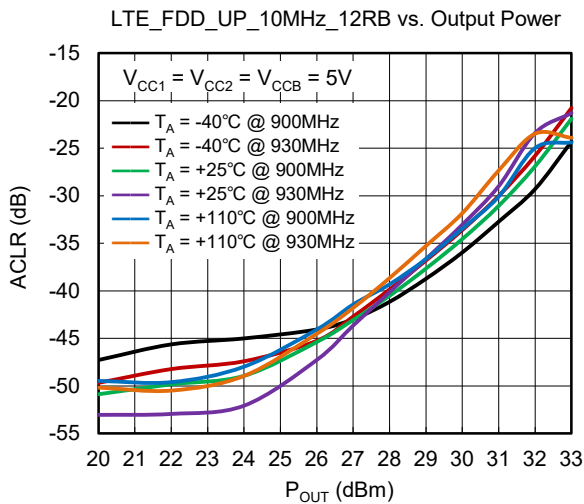
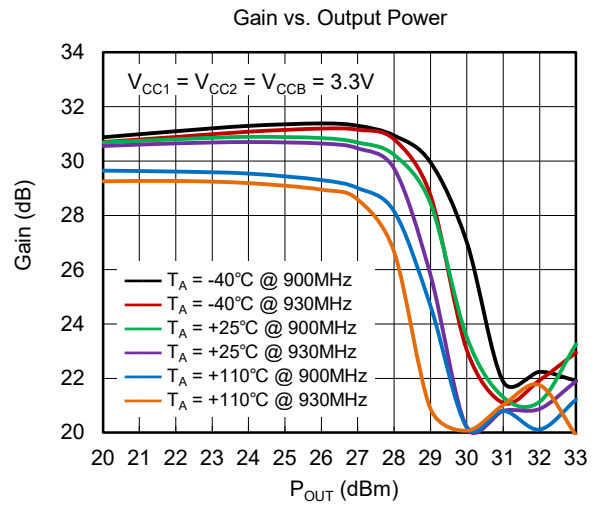
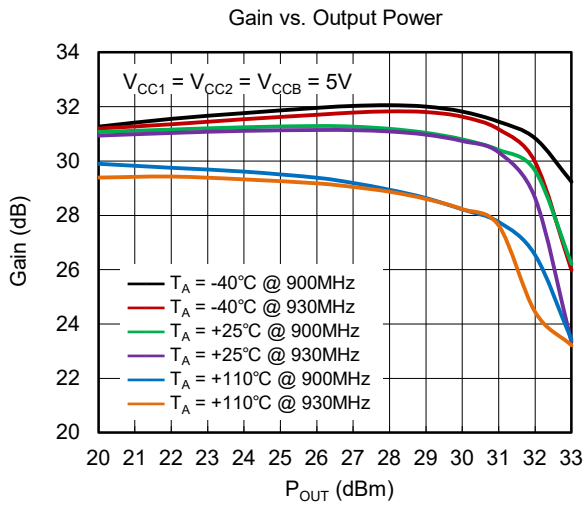

TYPICAL APPLICATION CIRCUIT

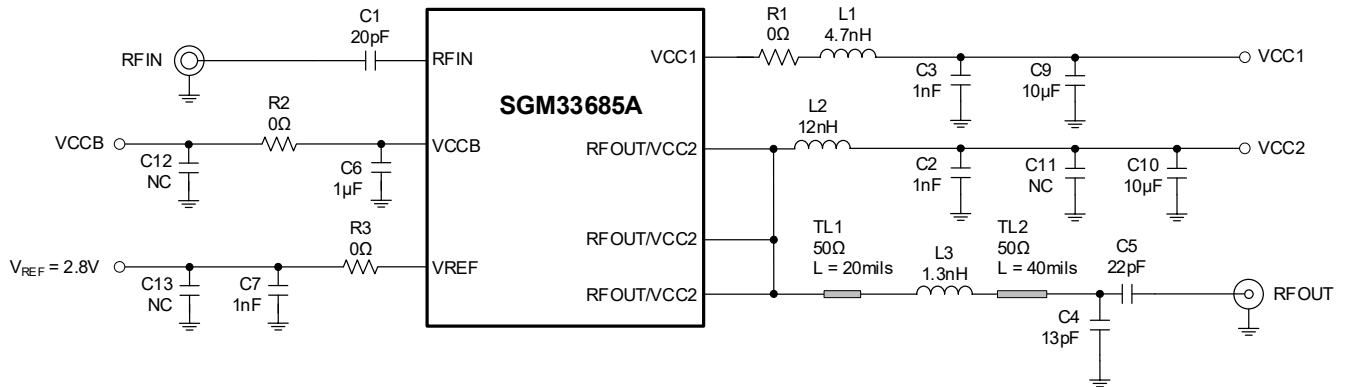

Figure 2. SGM33685A Typical Application Circuit

Table 1. Evaluation Board Bill of Material

COMPONENT	VALUE	DESCRIPTION
IC		SGM33685A
C1	20pF	Matching capacitor
C2, C3, C7	1nF	De-coupling capacitor
C6	1μF	De-coupling capacitor
C4	13pF	Matching capacitor(GJM)
C5	22pF	DC blocking capacitor(GJM)
C9, C10	10μF	Matching capacitor
C11, C12, C13	NC	No connection
R1, R2, R3	0Ω	
L1	4.7nH	RF choke inductor
L2	12nH	RF choke inductor (Size 0603)
L3	1.3nH	Matching inductor

EVALUATION BOARD LAYOUT

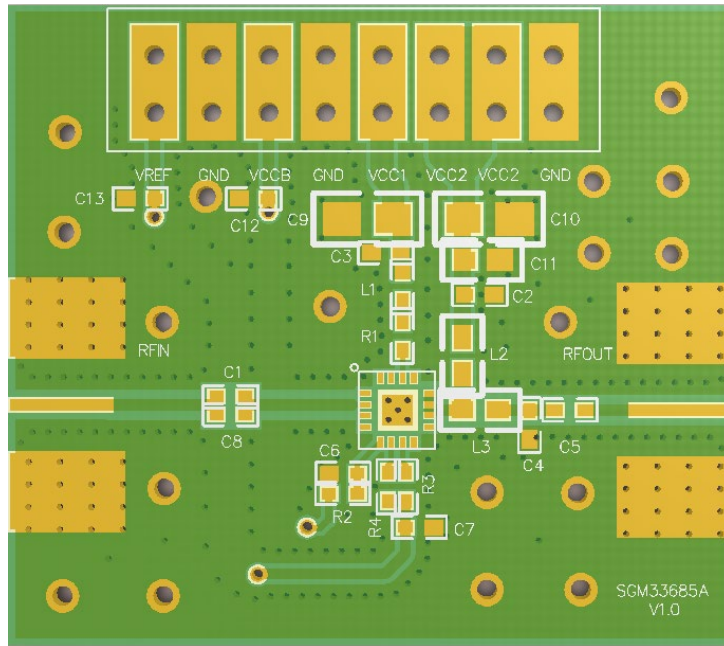

Figure 3. Evaluation Board Layout

REVISION HISTORY

NOTE: Page numbers for previous revisions may differ from page numbers in the current version.

JUNE 2026 – REV.A.1 to REV.A.2	Page
Updated Recommended Operating Conditions, Typical Application Circuit and Evaluation Board Layout.....	2, 6, 7
MAY 2024 – REV.A to REV.A.1	Page
Updated Absolute Maximum Ratings.....	2
Changes from Original (FEBRUARY 2024) to REV.A	Page
Changed from product preview to production data.....	All

PACKAGE OUTLINE DIMENSIONS

TQFN-3×3-16L

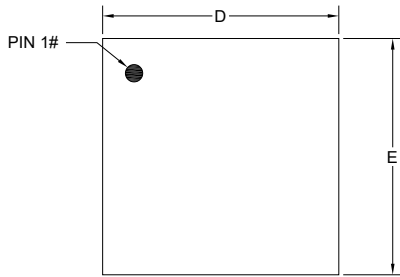

TOP VIEW

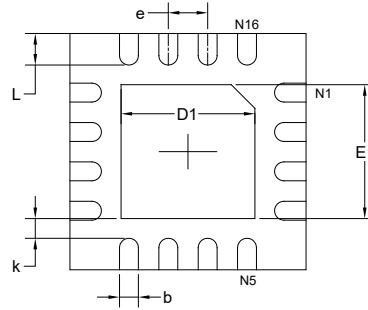

BOTTOM VIEW

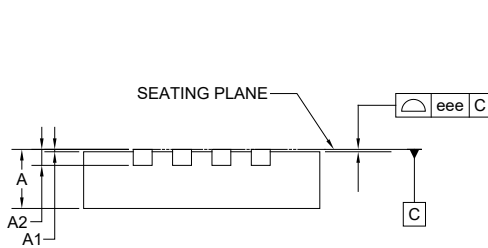

SIDE VIEW

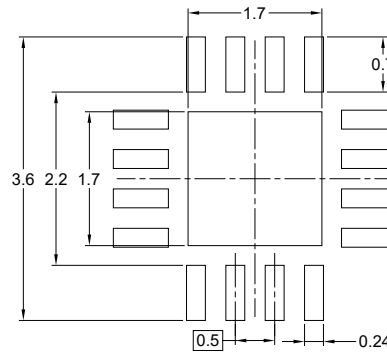

RECOMMENDED LAND PATTERN (Unit: mm)

Symbol	Dimensions In Millimeters		Dimensions In Inches	
	MIN	MAX	MIN	MAX
A	0.700	0.800	0.028	0.031
A1	0.000	0.050	0.000	0.002
A2	0.203 REF		0.008 REF	
D	2.900	3.100	0.114	0.122
D1	1.600	1.800	0.063	0.071
E	2.900	3.100	0.114	0.122
E1	1.600	1.800	0.063	0.071
k	0.200 MIN		0.008 MIN	
b	0.180	0.300	0.007	0.012
e	0.500 TYP		0.020 TYP	
L	0.300	0.500	0.012	0.020
eee	0.080		0.003	

NOTE: This drawing is subject to change without notice.

TAPE AND REEL INFORMATION

REEL DIMENSIONS

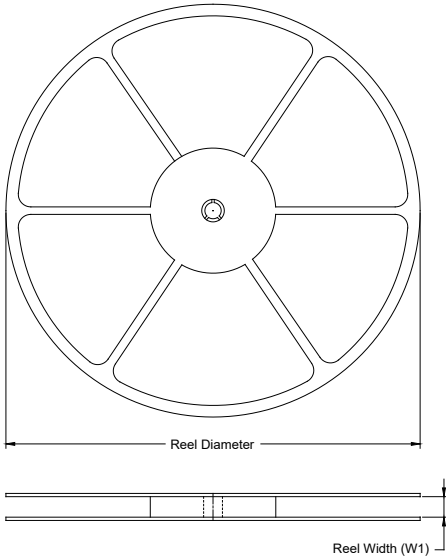

TAPE DIMENSIONS

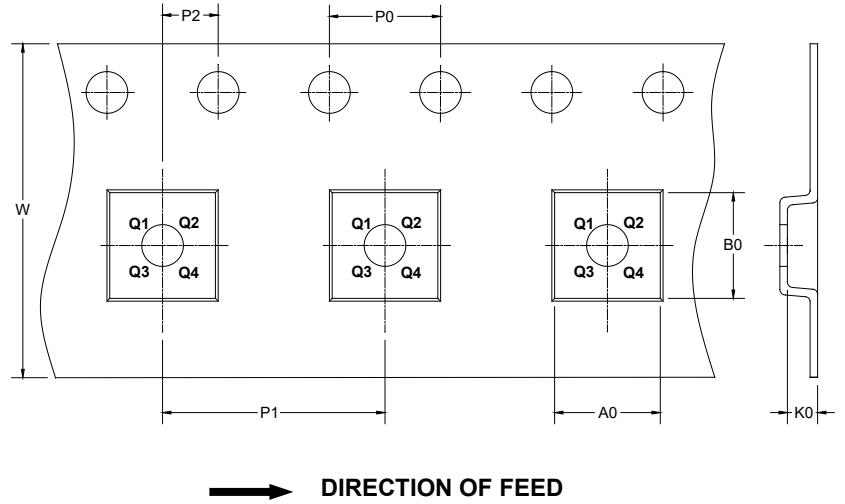

NOTE: The picture is only for reference. Please make the object as the standard.

KEY PARAMETER LIST OF TAPE AND REEL

Package Type	Reel Diameter	Reel Width W1 (mm)	A0 (mm)	B0 (mm)	K0 (mm)	P0 (mm)	P1 (mm)	P2 (mm)	W (mm)	Pin1 Quadrant
TQFN-3×3-16L	13"	12.4	3.30	3.30	1.10	1.50	4.0	8.0	2.0	12.0

DD0001

PACKAGE INFORMATION

CARTON BOX DIMENSIONS

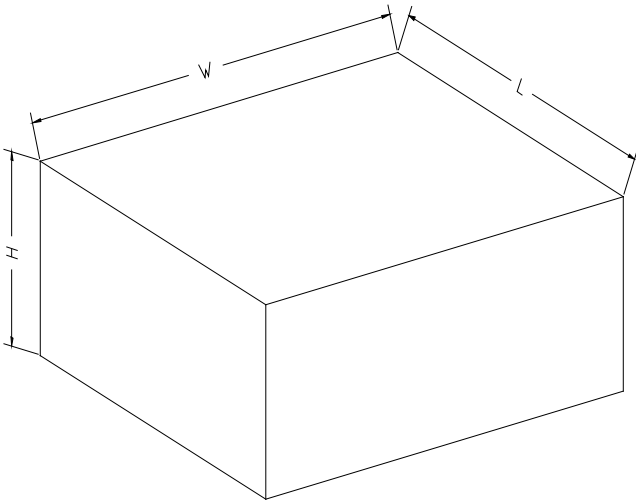

NOTE: The picture is only for reference. Please make the object as the standard.

KEY PARAMETER LIST OF CARTON BOX

Reel Type	Length (mm)	Width (mm)	Height (mm)	Pizza/Carton
13"	386	280	370	5

DD0002