



SGM6027/SGM6027A/SGM6027B/SGM6027C

Ultra-Low Quiescent Current HPCM Synchronous Buck Converters

GENERAL DESCRIPTION

The SGM6027, SGM6027A, SGM6027B and SGM6027C are small and efficient 2.5V to 5.5V synchronous Buck converters with ultra-low quiescent current (580nA, TYP). The SGM6027 and SGM6027C outputs can be programmed to 8 selectable output voltages from 1.2V to 3.3V by 3 logic selected pins. They can deliver up to 600mA output current continuously or 1310mA peak for a short time. For the SGM6027A, the 8 programmable voltages are in the range of 0.7V to 3.1V and the output can deliver 600mA continuous output current or 870mA peak. For the SGM6027B, the 8 programmable voltages are in the range of 1.3V to 3.1V and the output can deliver 600mA continuous output current or 870mA peak. All the devices offer high efficiency at light loads by entering into the PFM mode.

Optimal transient response is achieved by internally compensated hysteretic peak current mode (HPCM) control that is stable over a wide range of output capacitances and loads.

The SGM6027, SGM6027A, SGM6027B and SGM6027C are available in a Green WLCSP-0.8×1.6-8B package.

FEATURES

- **Input Voltage Range: 2.5V to 5.5V**
- **8 Selectable Output Voltage Levels**
 - ♦ SGM6027 and SGM6027C: 1.2V to 3.3V
 - ♦ SGM6027A: 0.7V to 3.1V
 - ♦ SGM6027B: 1.3V to 3.1V
- **Output Current**
 - ♦ SGM6027: 600mA Continuous, 1310mA Peak
 - ♦ SGM6027C: 600mA Continuous, 1310mA Peak
 - ♦ SGM6027A: 600mA Continuous, 870mA Peak
 - ♦ SGM6027B: 600mA Continuous, 870mA Peak
- **580nA Typical Quiescent Current**
- **PFM Operation**
- **Up to 92% Efficiency**
- **Internal Compensation**
- **Enable Input**
- **Output Voltage Discharge**
 - ♦ SGM6027/SGM6027A/SGM6027B: 20Ω (TYP)
 - ♦ SGM6027C: 120Ω (TYP)
- **Over-Current Protection (OCP)**
- **Under-Voltage Lockout (UVLO) Protection**
- **Over-Temperature Protection (OTP)**
- **Available in a Green WLCSP-0.8×1.6-8B Package**

APPLICATIONS

IoT
Battery-Powered Equipment
Portable Devices
Wearable Devices

TYPICAL APPLICATION

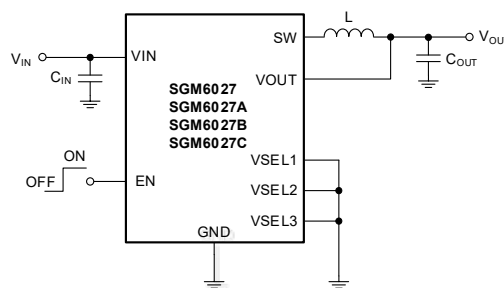

Figure 1. Typical Application Circuit

PACKAGE/ORDERING INFORMATION

MODEL	PACKAGE DESCRIPTION	SPECIFIED TEMPERATURE RANGE	ORDERING NUMBER	PACKAGE MARKING	PACKING OPTION
SGM6027	WLCSP-0.8×1.6-8B	-40°C to +85°C	SGM6027YG/TR	XXXXX G5JYG	Tape and Reel, 3000
SGM6027A	WLCSP-0.8×1.6-8B	-40°C to +85°C	SGM6027AYG/TR	XXXXX G5IYG	Tape and Reel, 3000
SGM6027B	WLCSP-0.8×1.6-8B	-40°C to +85°C	SGM6027BYG/TR	XXXXX G5KYG	Tape and Reel, 3000
SGM6027C	WLCSP-0.8×1.6-8B	-40°C to +85°C	SGM6027CYG/TR	XXXXX 2T2YG	Tape and Reel, 3000

MARKING INFORMATION

NOTE: XXXXX = Date Code, Trace Code and Vendor Code.

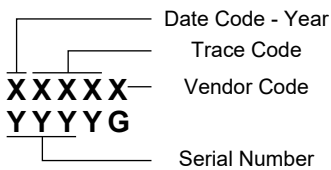

Green (RoHS & HSF): SG Micro Corp defines "Green" to mean Pb-Free (RoHS compatible) and free of halogen substances. If you have additional comments or questions, please contact your SGMICRO representative directly.

ABSOLUTE MAXIMUM RATINGS

VIN, SW, EN, VSEL1, VSEL2, VSEL3, VOUT..... -0.3V to 6V
 Package Thermal Resistance
 WLCSP-0.8×1.6-8B, θ_{JA} 134°C/W
 WLCSP-0.8×1.6-8B, θ_{JB} 40.7°C/W
 WLCSP-0.8×1.6-8B, θ_{JC} 47.2°C/W
 Junction Temperature..... +150°C
 Storage Temperature Range..... -65°C to +150°C
 Lead Temperature (Soldering, 10s)..... +260°C
 ESD Susceptibility ^{(1) (2)}
 HBM..... ±4000V
 CDM ±1000V

NOTES:

1. For human body model (HBM), all pins comply with ANSI/ESDA/JEDEC JS-001 specifications.
2. For charged device model (CDM), all pins comply with ANSI/ESDA/JEDEC JS-002 specifications.

RECOMMENDED OPERATING CONDITIONS

Supply Input Voltage Range 2.5V to 5.5V
 SGM6027/SGM6027A/SGM6027B/SGM6027C Output
 Current Range, $V_{OUT_NOM} + 0.7V \leq V_{IN}$ 600mA
 Operating Ambient Temperature Range..... -40°C to +85°C

OVERSTRESS CAUTION

Stresses beyond those listed in Absolute Maximum Ratings may cause permanent damage to the device. Exposure to absolute maximum rating conditions for extended periods may affect reliability. Functional operation of the device at any conditions beyond those indicated in the Recommended Operating Conditions section is not implied.

ESD SENSITIVITY CAUTION

This integrated circuit can be damaged if ESD protections are not considered carefully. SGMICRO recommends that all integrated circuits be handled with appropriate precautions. Failure to observe proper handling and installation procedures can cause damage. ESD damage can range from subtle performance degradation to complete device failure. Precision integrated circuits may be more susceptible to damage because even small parametric changes could cause the device not to meet the published specifications.

DISCLAIMER

SG Micro Corp reserves the right to make any change in circuit design, or specifications without prior notice.

PIN CONFIGURATION

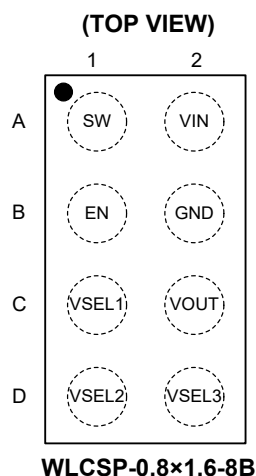

PIN DESCRIPTION

PIN	NAME	TYPE	DESCRIPTION
A1	SW	O	Switching Node Output. Connect it to the external inductor with small copper area and path length to reduce EMI and switching noise coupling to the nearby traces.
A2	VIN	I	Supply Input. Place a low ESR ceramic capacitor (at least 10 μ F for SGM6027 and SGM6027C or 4.7 μ F for SGM6027A and SGM6027B) as close as possible to the device between this pin and GND.
B1	EN	I	Active High Chip Enable Input. Must be pulled high to enable the device or pulled low to turn the device off. Do not leave this pin floating.
B2	GND	G	Ground Pin. This pin should be connected to input and output capacitors with the shortest path.
C1	VSEL1	I	Logic Input 1 for Output Voltage Selection. Connect to VIN or GND pin and do not leave floating.
C2	VOUT	O	Output Voltage Pin. Connect this pin to the load terminal near an output capacitor for better voltage regulation. Use at least a 10 μ F (effective value) ceramic capacitor between this pin and GND close to the chip.
D1	VSEL2	I	Logic Input 2 for Output Voltage Selection. Connect to VIN or GND pin and do not leave floating.
D2	VSEL3	I	Logic Input 3 for Output Voltage Selection. Connect to VIN or GND pin and do not leave floating.

NOTE: I = input, O = output, I/O = input/output, P = power, G = ground.

ELECTRICAL CHARACTERISTICS

($V_{IN} = 3.6V$, $V_{OUT} = 1.8V$ (SGM6027 and SGM6027C), $V_{OUT} = 1.9V$ (SGM6027A and SGM6027B), $C_{IN} = C_{OUT} = 10\mu F$, $L_1 = 2.2\mu H$, minimum and maximum values are at $T_J = -40^\circ C$ to $+85^\circ C$, typical values are at $T_J = +25^\circ C$, unless otherwise noted.)

PARAMETER	SYMBOL	CONDITIONS	MIN	TYP	MAX	UNITS	
Buck Regulator							
Under-Voltage Lockout Rising Threshold	V_{UVLO_R}	V_{IN} rising		2.26	2.35	V	
Under-Voltage Lockout Hysteresis	V_{UVLO_HYS}			0.25	0.40	V	
VOUT Voltage Accuracy	V_{OUT_ACC}	$T_J = +25^\circ C$	-1.5		2.5	%	
Input Quiescent Current	I_Q	$I_{OUT} = 0A$, $EN = V_{IN}$, non-switching		580	1000	nA	
Shutdown Current	I_{SD}	$EN = GND$		10	1000	nA	
Switching Frequency	f_{SW}	CCM mode		1.2		MHz	
High-side (HS) Current Limit	I_{L_HS}	SGM6027/SGM6027C	$T_J = +25^\circ C$	1.16	1.31	1.43	A
		SGM6027A/SGM6027B	$T_J = +25^\circ C$	0.78	0.87	0.96	
High-side R_{ON}	R_{ON_HS}	$I_{OUT} = 50mA$		330	480	m Ω	
Low-side R_{ON}	R_{ON_LS}	$I_{OUT} = 50mA$		230	360	m Ω	
Output Discharge Resistor	R_{DIS}	SGM6027/SGM6027A/SGM6027B, $EN = GND$, $I_{OUT} = -10mA$		20		Ω	
		SGM6027C, $EN = GND$, $I_{OUT} = -10mA$		120			
Line Regulation	$V_{OUT_LineReg}$	$I_{OUT} = 100mA$, $V_{IN} = 2.5V$ to $5.5V$		0.1		%/V	
Load Regulation	$V_{OUT_LoadReg}$	CCM operation only		0.0005		%/mA	
Over-Temperature Protection	T_{OTP}			150		$^\circ C$	
Over-Temperature Protection Hysteresis	T_{OTP_HYS}			20		$^\circ C$	
Timing							
Regulator Startup Delay Time	t_{SS_EN}	$EN = GND$ to V_{IN} , V_{OUT} starts rising		0.6		ms	
Regulator Soft-Start Time	t_{SS}	$I_{OUT} = 10mA$, $EN = V_{IN}$		0.3		ms	
Logic Inputs (EN, VSEL1, VSEL2 and VSEL3)							
Input High Threshold	V_{IH}	$V_{IN} = 2.5V$ to $5.5V$	1.2			V	
Input Low Threshold	V_{IL}	$V_{IN} = 2.5V$ to $5.5V$			0.4	V	
Input Pin Bias Current	I_{IN}			10		nA	

TYPICAL PERFORMANCE CHARACTERISTICS

At $T_J = +25^\circ\text{C}$, unless otherwise noted.

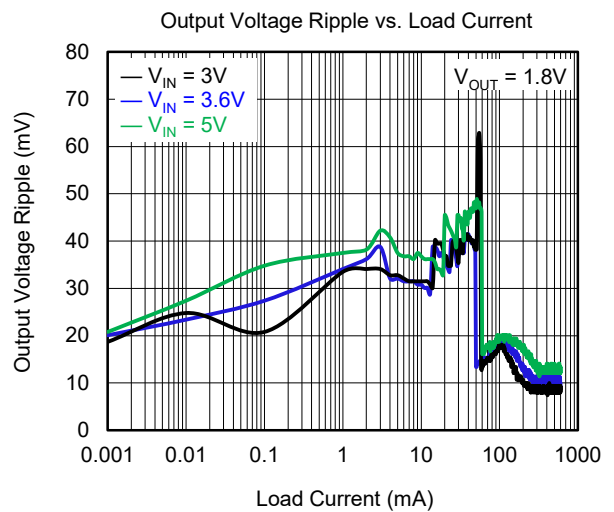
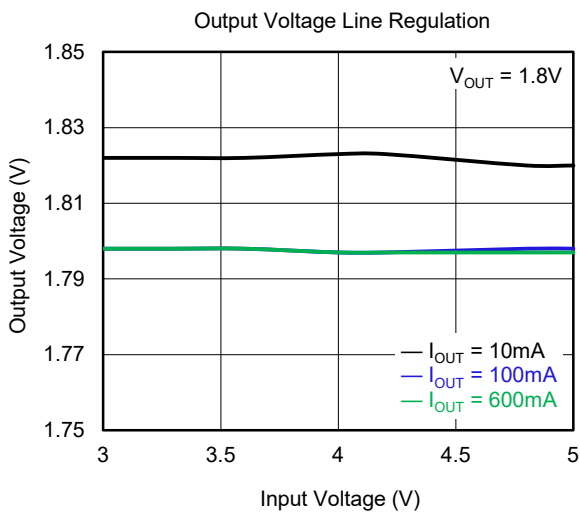
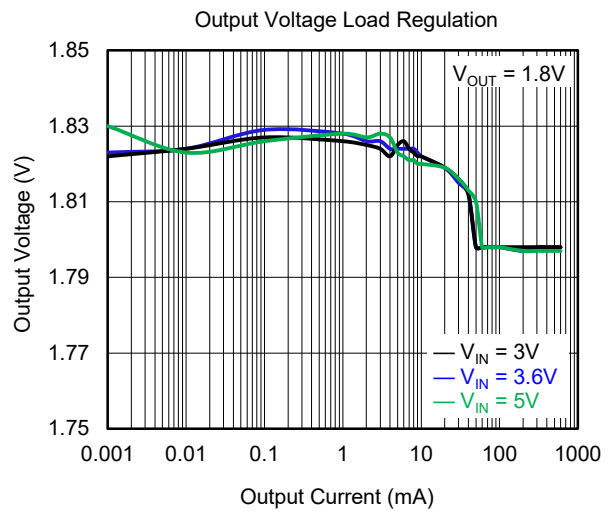
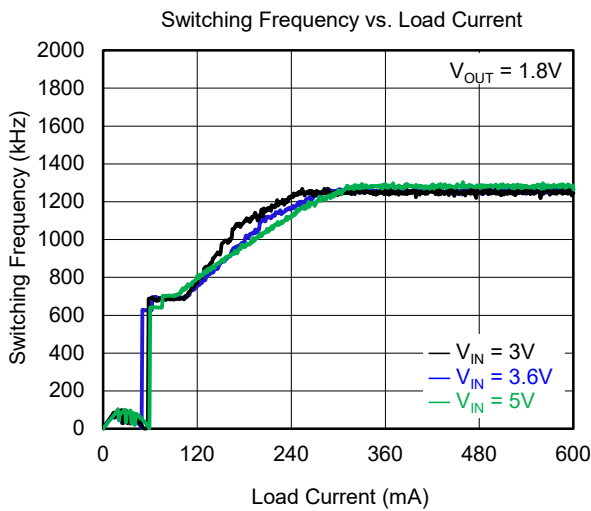
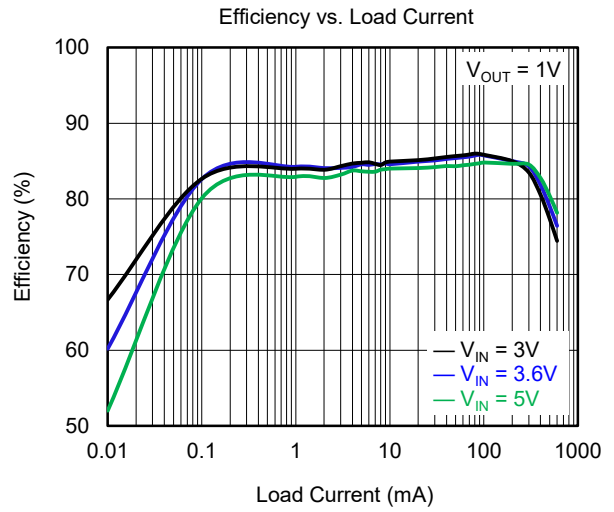
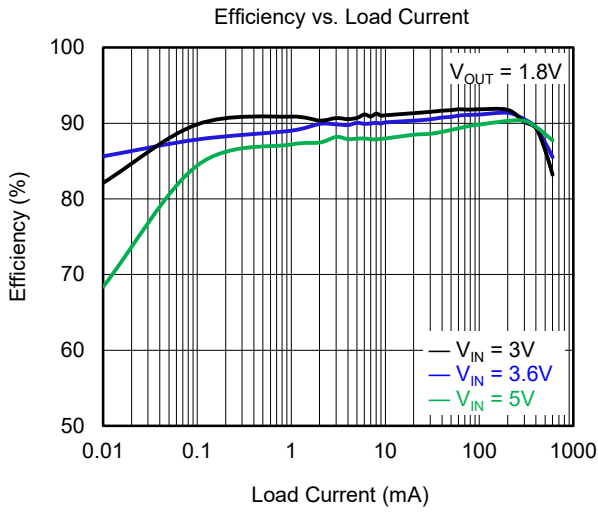

TYPICAL PERFORMANCE CHARACTERISTICS (continued)

At $T_J = +25^\circ\text{C}$, unless otherwise noted.

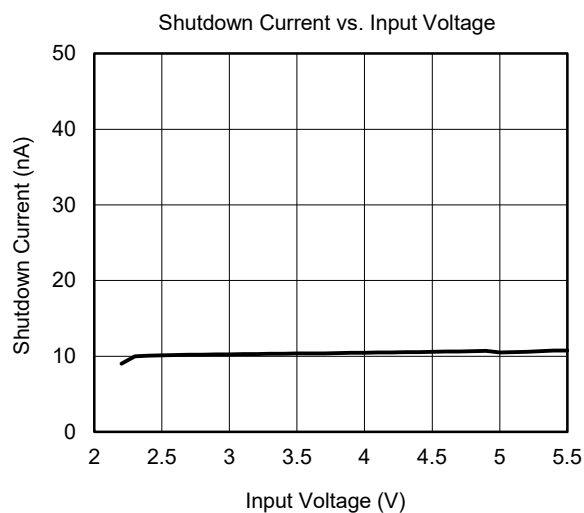
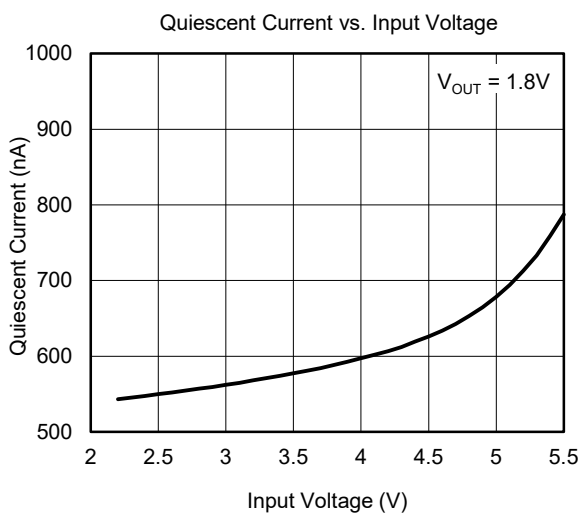

TYPICAL PERFORMANCE CHARACTERISTICS (continued)

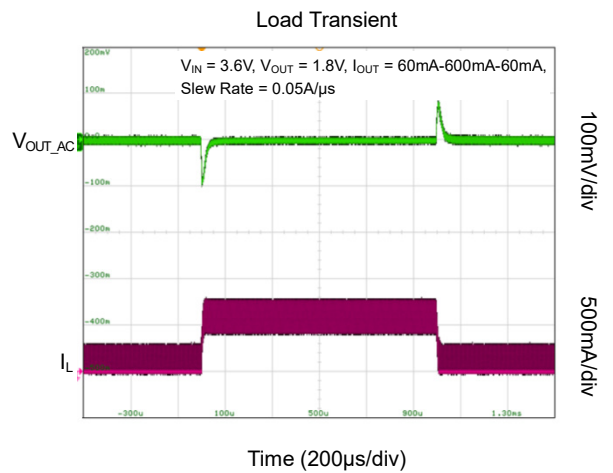
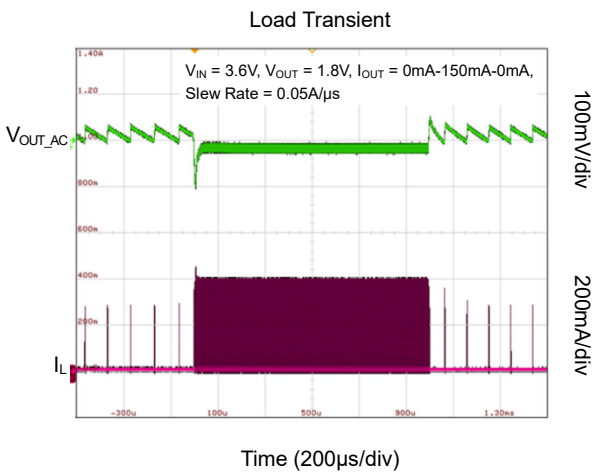
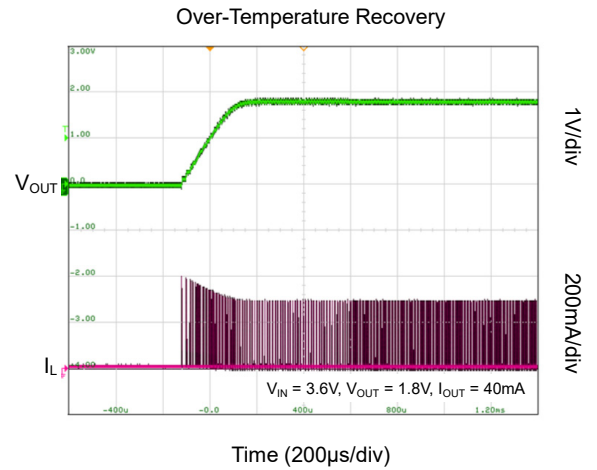
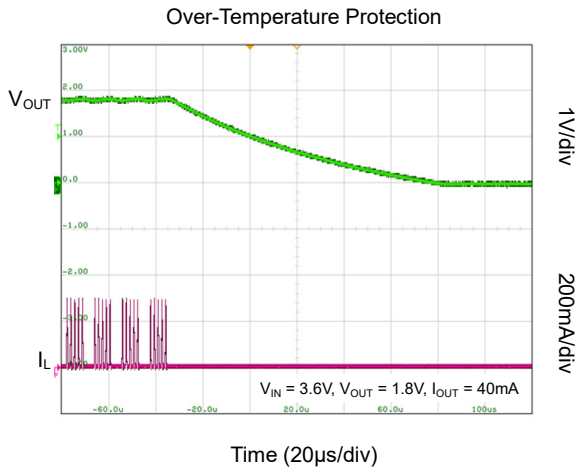
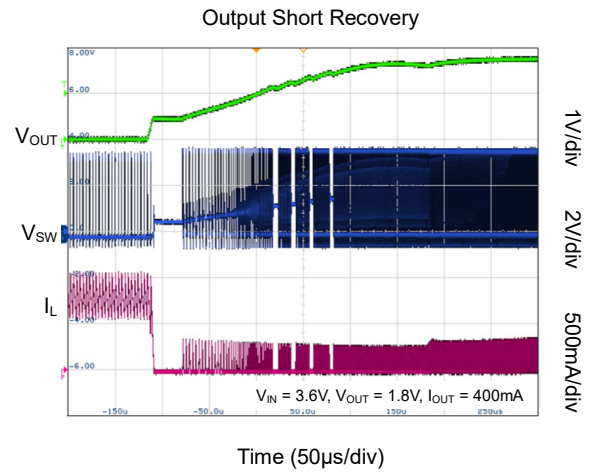
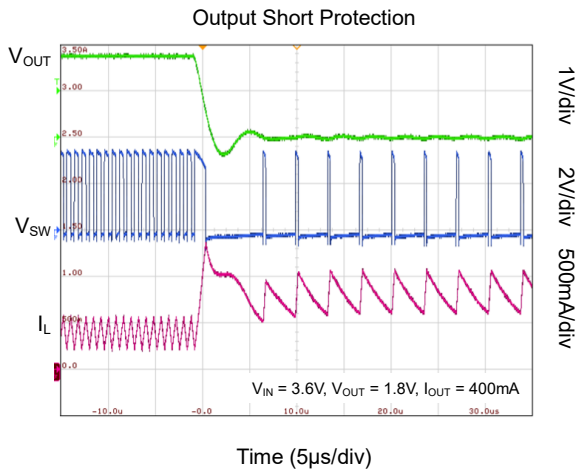

TYPICAL PERFORMANCE CHARACTERISTICS (continued)

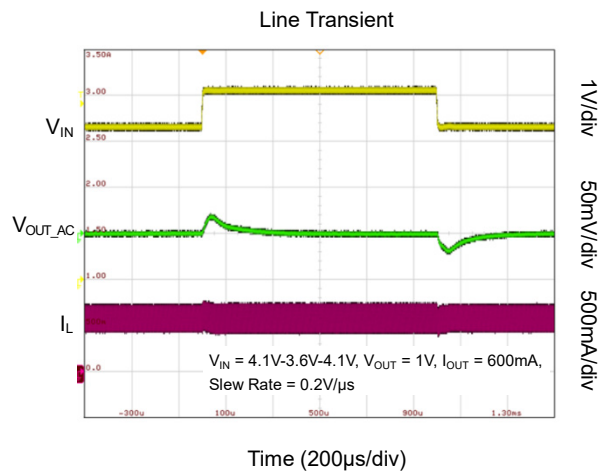
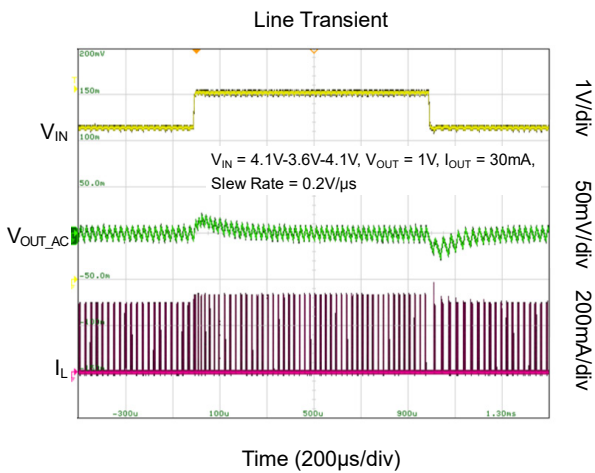
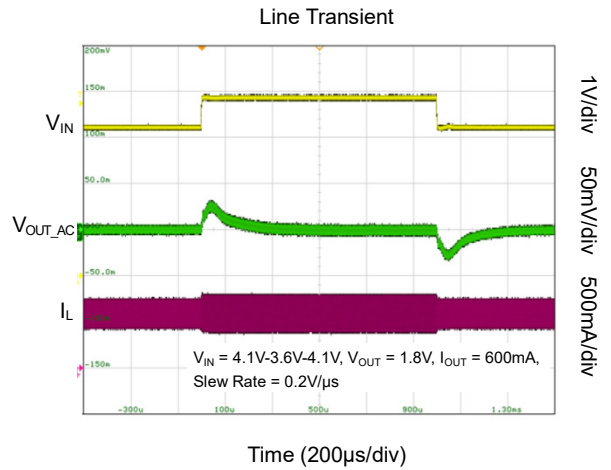
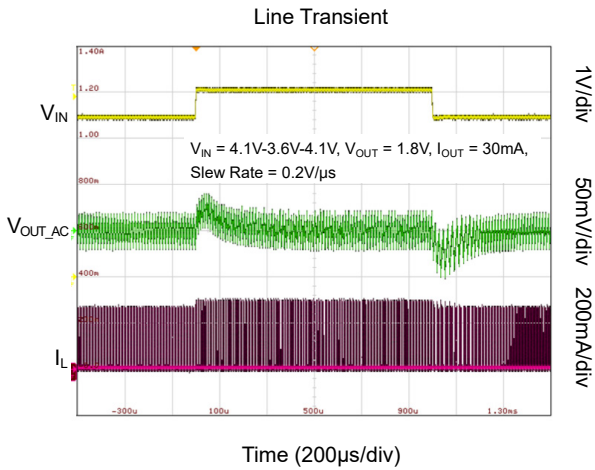
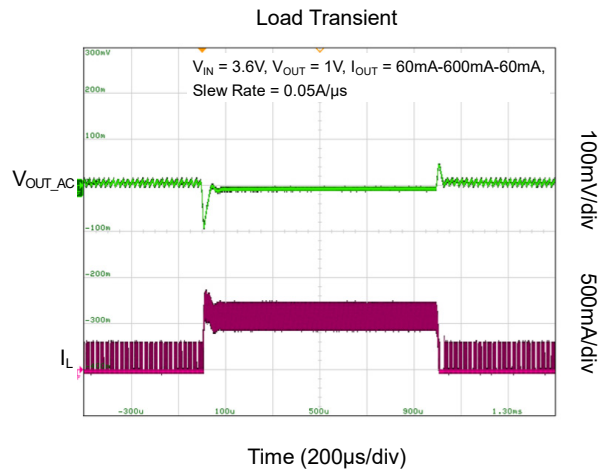
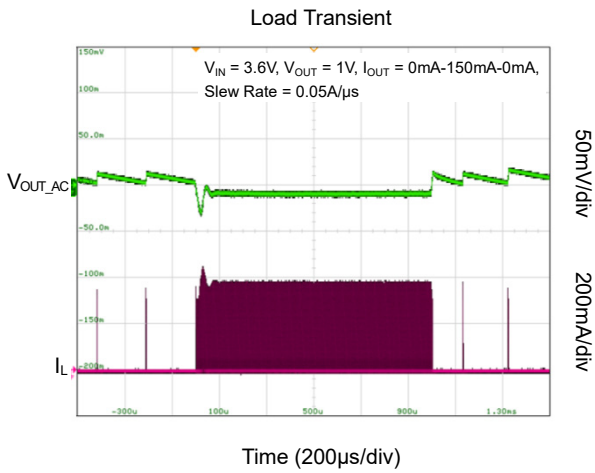

TYPICAL PERFORMANCE CHARACTERISTICS (continued)

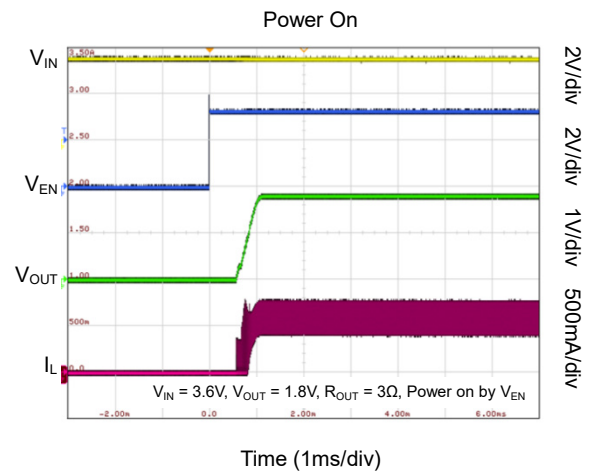
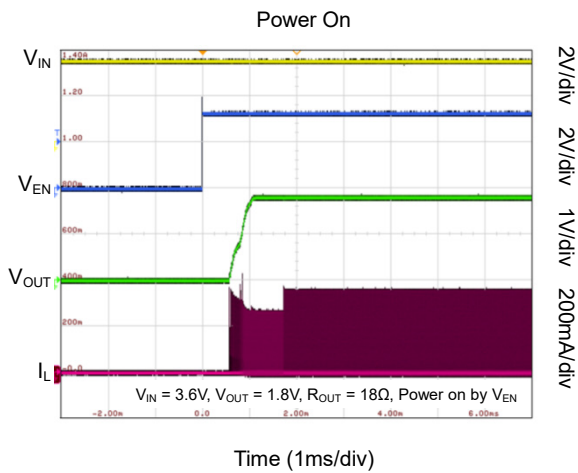
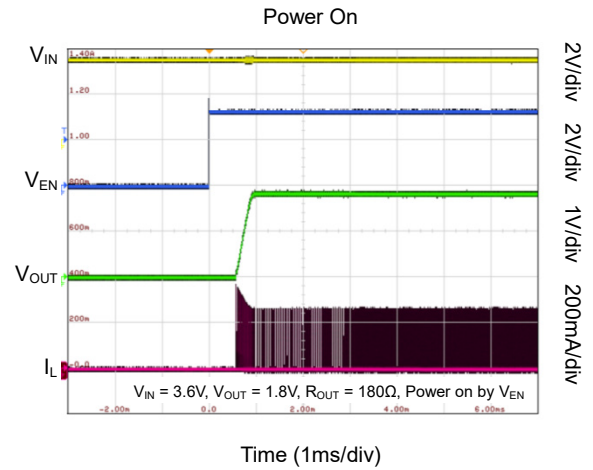
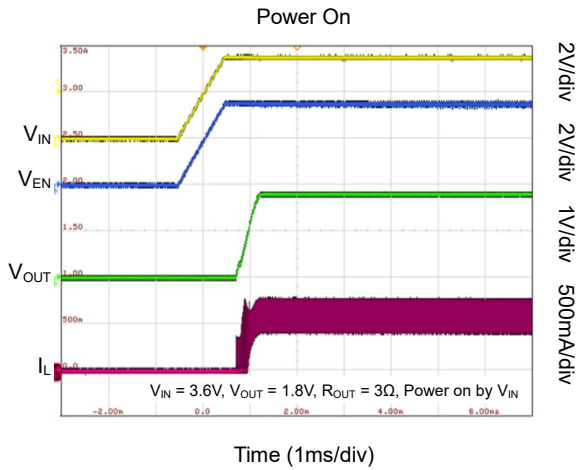
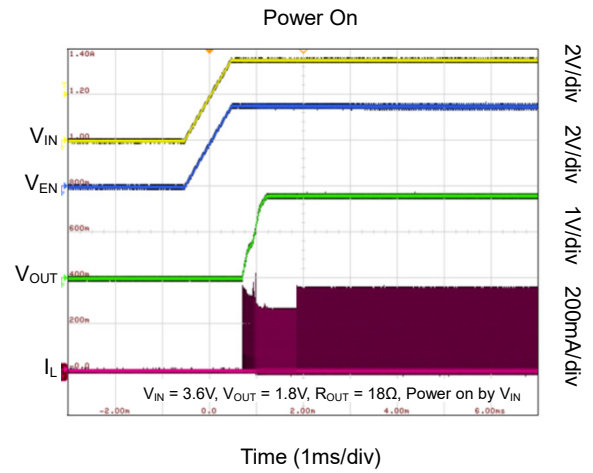
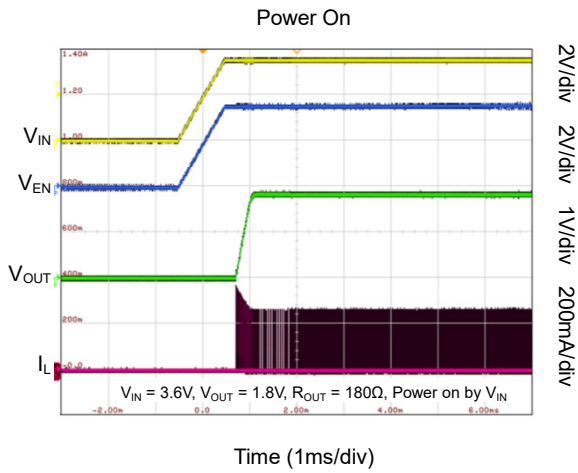

TYPICAL PERFORMANCE CHARACTERISTICS (continued)

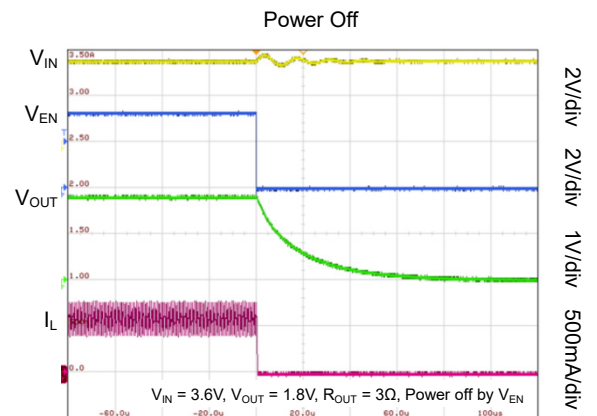
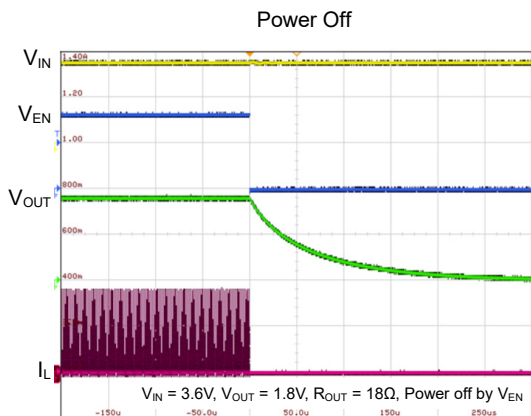
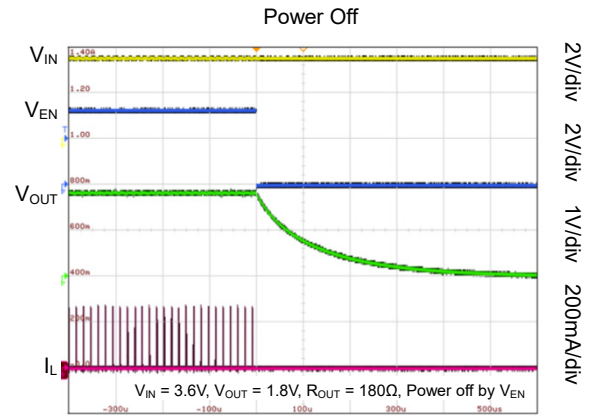
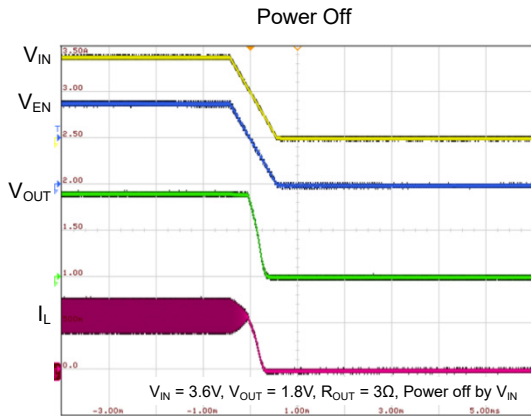
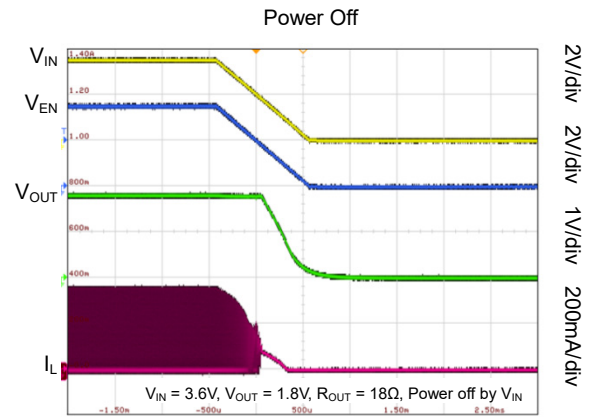
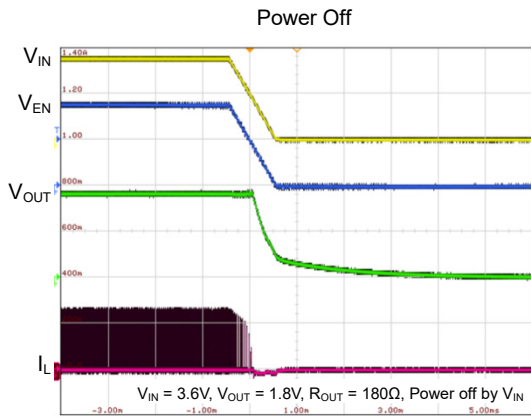

TYPICAL PERFORMANCE CHARACTERISTICS (continued)

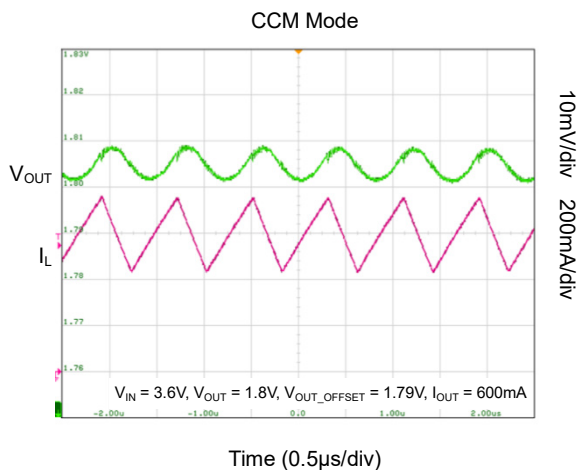
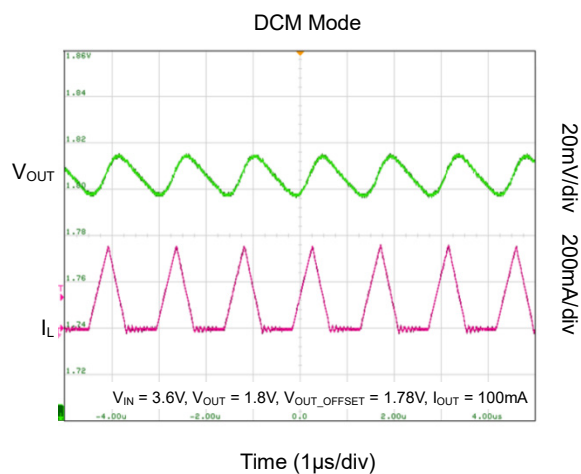
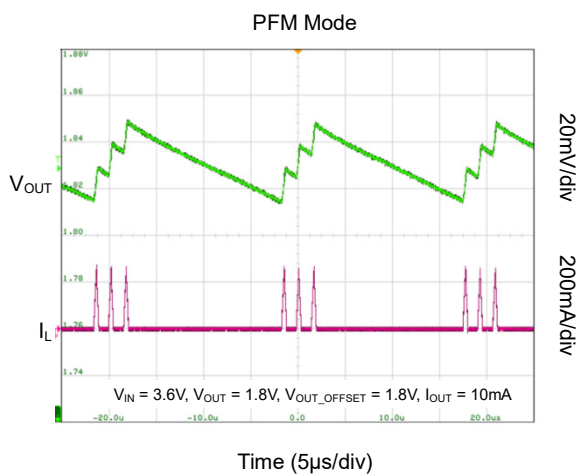

FUNCTIONAL BLOCK DIAGRAM

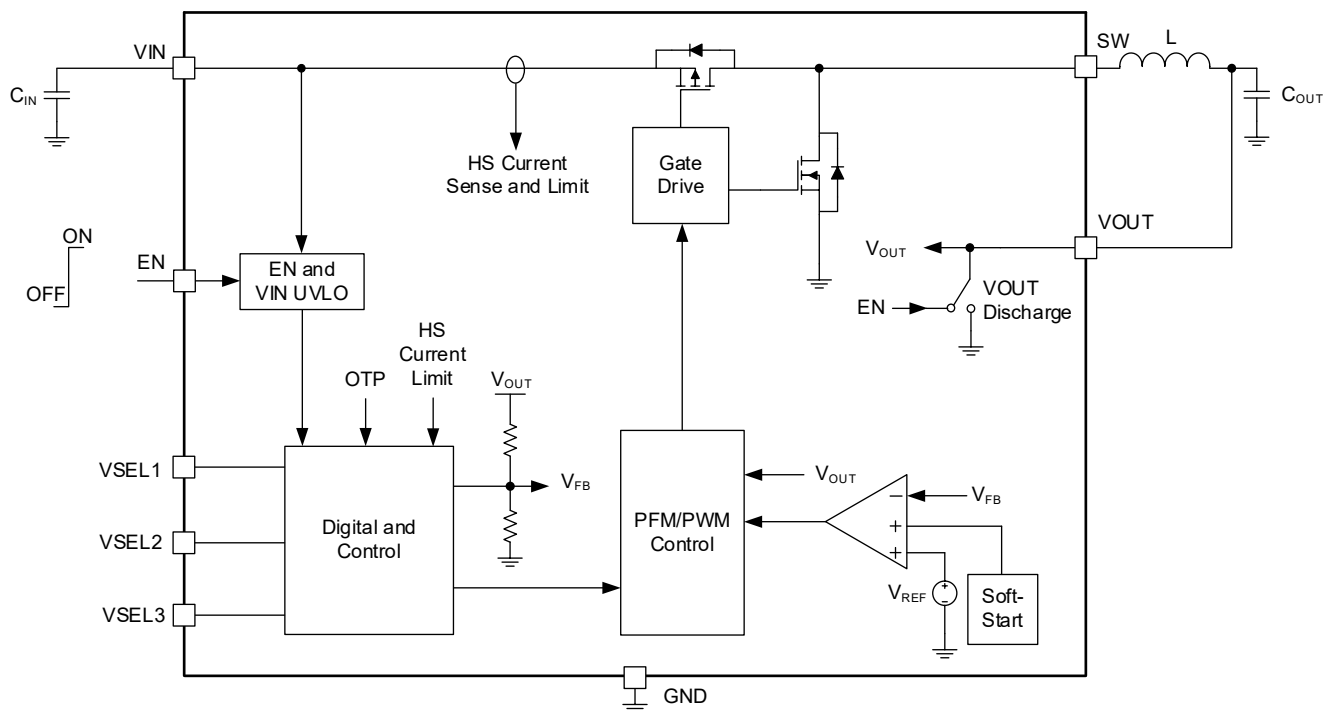

Figure 2. Functional Block Diagram

DETAILED DESCRIPTION

Operating Description

The SGM6027, SGM6027A, SGM6027B and SGM6027C are hysteretic peak current mode (HPCM) control synchronous Buck converters with ultra-low quiescent currents of less than 1µA when EN input is pulled high. For safe operation, they also provide under-voltage lockout, over-current protection and over-temperature protection. Packaged in the space-saving 0.8mm × 1.6mm WLCSP package and requiring ultra-low quiescent current, the SGM6027 series is ideal for portable applications.

Under-Voltage Lockout (UVLO)

To protect the device from malfunctioning when the input voltage is insufficient, under-voltage lockout (UVLO) is included. The device will not operate until the input voltage exceeds UVLO rising threshold, and will lockout if the input voltage falls below the UVLO falling threshold.

Over-Current Protection (OCP)

The inductor current is monitored for the OCP function. If the inductor current exceeds the current limit threshold, the high-side switch will be turned off. During OCP, the output voltage falls below $0.8 \times V_{OUT}$ and the current limit level and switching frequency are decreased to reduce the losses and heat. The internal OCP detection circuit response delay and the inductor current rising rate before reaching the peak current limit determine the actual inductor peak current that should be considered for inductor design.

Thermal Shutdown (OTP)

To protect the device from overheating damage, thermal protection is included in the device. If the junction temperature (T_J) exceeds the OTP threshold (+150°C TYP), the switching will stop. When the die cools down and T_J falls below OTP falling threshold (+130°C TYP), the switching resumes automatically.

Output Voltage Selection

8 selectable output voltage levels can be digitally selected for SGM6027, SGM6027A, SGM6027B and SGM6027C. The VSEL1 to VSEL3 logic pins determine the output voltage as listed in Table 1.

Table 1 Output Voltage Setting

Device	V _{OUT} (V)	VSEL3	VSEL2	VSEL1
SGM6027 & SGM6027C	1.2	0	0	0
	1.5	0	0	1
	1.8	0	1	0
	2.1	0	1	1
	2.5	1	0	0
	2.8	1	0	1
	3	1	1	0
	3.3	1	1	1
SGM6027A	0.7	0	0	0
	1	0	0	1
	1.3	0	1	0
	1.6	0	1	1
	1.9	1	0	0
	2	1	0	1
	2.9	1	1	0
	3.1	1	1	1
SGM6027B	1.3	0	0	0
	1.4	0	0	1
	1.6	0	1	0
	1.7	0	1	1
	1.9	1	0	0
	2	1	0	1
	2.9	1	1	0
	3.1	1	1	1

APPLICATION INFORMATION

The SGM6027, SGM6027A, SGM6027B and SGM6027C are miniature Buck converters with 2.5V to 5.5V input voltage range. The maximum continuous output current for the SGM6027 and SGM6027C is 600mA (1310mA peak). For the SGM6027A and SGM6027B, the maximum continuous output current is 600mA (870mA peak). They are internally compensated and no external component is needed. Protection features include over-current protection (OCP), under-voltage lockout (UVLO) and over-temperature protection (OTP).

Typical Application

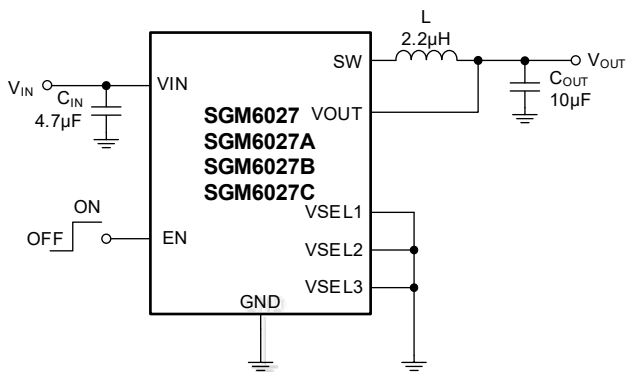

Figure 3. Typical Application Circuit

Inductor

Use a 2.2µH inductor with saturation current above the OCP peak level. Choose a low DCR inductor for higher efficiency and better performance.

Input and Output Capacitors (C_{IN} and C_{OUT})

To filter the input switching currents and prevent large input voltage ripple, a low ESR capacitor is needed. The current rating of the C_{IN} capacitor is given by Equation 1:

$$I_{RMS} = I_{OUT(MAX)} \times \frac{V_{OUT}}{V_{IN}} \times \sqrt{\frac{V_{IN}}{V_{OUT}} - 1} \quad (1)$$

where I_{OUT(MAX)} is the maximum DC output current and I_{RMS} is the input capacitor RMS current. The maximum I_{RMS} occurs when V_{IN} = 2 × V_{OUT} and is equal to I_{OUT}/2. For design, consider the worst case of V_{OUT} = V_{IN}/2 even if the operating condition is different. Also consider the thermal and voltage derating of the capacitors. Use multiple capacitors in parallel if height restrictions do not allow a single capacitor for the required ratings. Output capacitance value and its ESR are the two main factors for selecting C_{OUT}. Low ESR is

needed to minimize the output ripple and transient over or undershoots in response to rapid load changes. The output ripple, ΔV_{OUT}, can be calculated from Equation 2:

$$\Delta V_{OUT} = \Delta I_L \left[ESR + \frac{1}{8 \times f_{SW} \times C_{OUT}} \right] \quad (2)$$

where ΔI_L is the inductor peak-to-peak current. The C_{OUT} value is also an important factor for stable operation of the loop.

A 10µF ceramic capacitor is recommended as the output capacitor for SGM6027 series. To achieve better output ripple and load transient performance, a 22µF could be used as the output capacitor. For 0.7V output application, a 22µF output capacitor is recommended.

PCB Layout Guidelines

Good PCB layout is the key factor for high performance operation of a switching power supply regarding stability, regulation, efficiency, and other performance measures.

A list of guidelines for designing a PCB layout for SGM6027 series is provided below:

- ◆ Place the power components close together and connect them with short and wide routes.
- ◆ Minimize the area of the SW node and connect it to the inductor with a short and wide trace on the top layer. Keep sensitive analog traces away from this node and inductor.
- ◆ Typical suggested layout is provided in Figure 4.

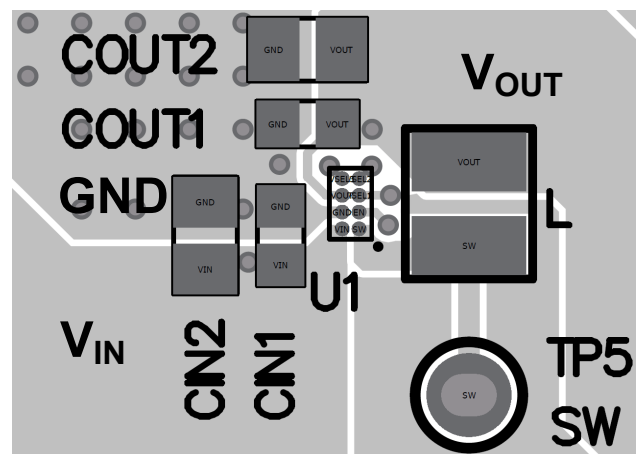

Figure 4. PCB Layout

REVISION HISTORY

NOTE: Page numbers for previous revisions may differ from page numbers in the current version.

MAY 2026 – REV.A to REV.A.1

Page

Added SGM6027CAll

Changes from Original to REV.A (JUNE 2022)

Page

Changed from product preview to production data.....All

PACKAGE OUTLINE DIMENSIONS

WLCSP-0.8x1.6-8B

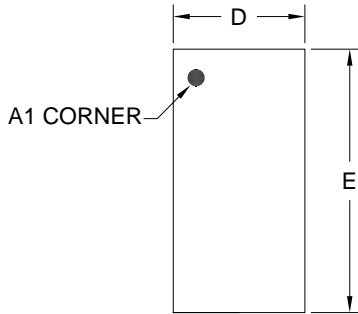

TOP VIEW

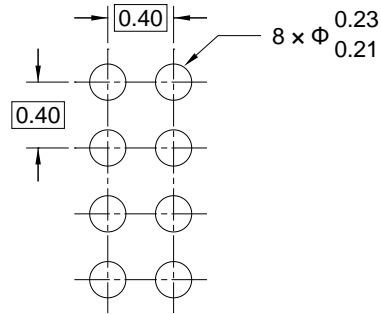

RECOMMENDED LAND PATTERN (Unit: mm)

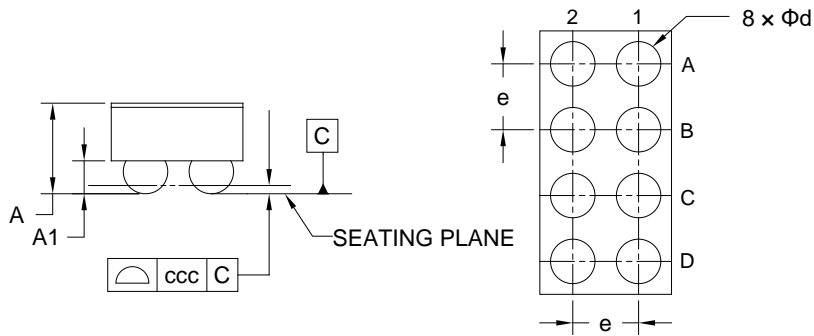

SIDE VIEW

BOTTOM VIEW

Symbol	Dimensions In Millimeters		
	MIN	MOD	MAX
A	0.505	0.550	0.595
A1	0.180	0.200	0.220
D	0.770	0.800	0.830
E	1.570	1.600	1.630
d	0.250	0.270	0.290
e	0.400 BSC		
ccc	-	0.040	-

NOTE: This drawing is subject to change without notice.

PACKAGE INFORMATION

TAPE AND REEL INFORMATION

REEL DIMENSIONS

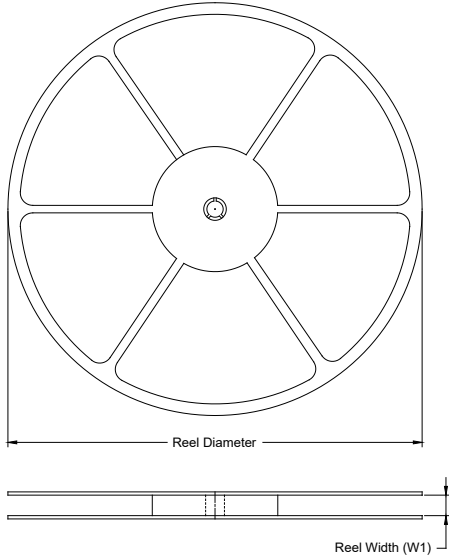

TAPE DIMENSIONS

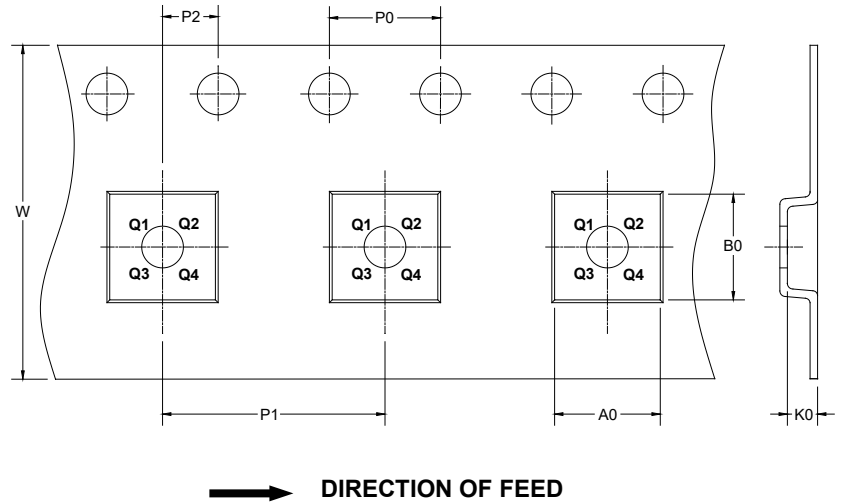

NOTE: The picture is only for reference. Please make the object as the standard.

KEY PARAMETER LIST OF TAPE AND REEL

Package Type	Reel Diameter	Reel Width W1 (mm)	A0 (mm)	B0 (mm)	K0 (mm)	P0 (mm)	P1 (mm)	P2 (mm)	W (mm)	Pin1 Quadrant
WLCSP-0.8×1.6-8B	7"	9.5	0.93	1.73	0.66	4.0	4.0	2.0	8.0	Q1

000001

PACKAGE INFORMATION

CARTON BOX DIMENSIONS

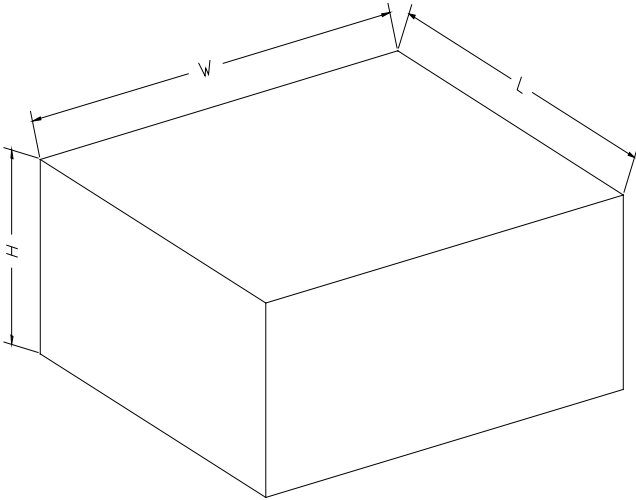

NOTE: The picture is only for reference. Please make the object as the standard.

KEY PARAMETER LIST OF CARTON BOX

Reel Type	Length (mm)	Width (mm)	Height (mm)	Pizza/Carton
7" (Option)	368	227	224	8
7"	442	410	224	18

DD0002