



SGM13005M2

Low Noise Amplifier with Bypass Switch for LTE Middle Band

GENERAL DESCRIPTION

The SGM13005M2 is a low noise amplifier (LNA) with bypass for LTE middle band receiving application. The device features low noise figure and high linearity over a supply voltage range from 1.5V to 3.6V. Low noise figure improves the sensitivity of the SGM13005M2, and high linearity enables the device to provide better immunity to interference signals.

No external DC blocking capacitors are required on the RF paths as long as no external DC voltage is applied, which can save PCB area and cost.

The SGM13005M2 is available in a Green UTDFN-1.1×0.7-6L package.

APPLICATIONS

- Cell Phones
- Tablets
- Other RF Front-End Modules

FEATURES

- **Operating Frequency Range: 1800MHz to 2200MHz**
- **Low Noise Figure: 1.0dB at 2000MHz**
- **Low Operation Current: 5.8mA**
- **Bypass Mode Current: 1µA (MAX)**
- **Single Supply Voltage Range: 1.5V to 3.6V**
- **Input and Output DC Decoupled**
- **Integrated Matching for the Output**
- **Available in a Green UTDFN-1.1×0.7-6L Package**

BLOCK DIAGRAM

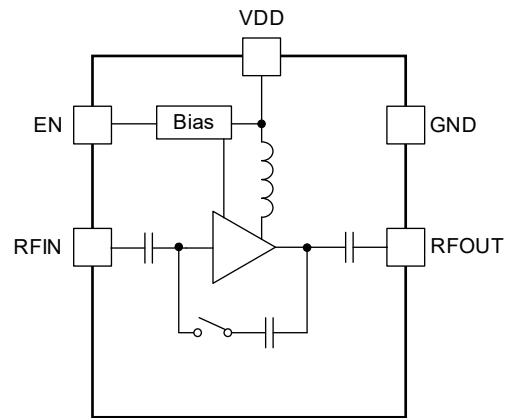

Figure 1. SGM13005M2 Block Diagram

PACKAGE/ORDERING INFORMATION

MODEL	PACKAGE DESCRIPTION	SPECIFIED TEMPERATURE RANGE	ORDERING NUMBER	PACKAGE MARKING	PACKING OPTION
SGM13005M2	UTDFN-1.1×0.7-6L	-40°C to +85°C	SGM13005M2YUEC6G/TR	04	Tape and Reel, 10000

MARKING INFORMATION

NOTE: Fixed character for 04.

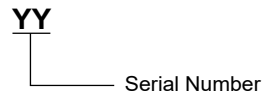

Green (RoHS & HSF): SG Micro Corp defines "Green" to mean Pb-Free (RoHS compatible) and free of halogen substances. If you have additional comments or questions, please contact your SGMICRO representative directly.

ABSOLUTE MAXIMUM RATINGS

Supply Voltage, V_{DD}	-0.3V to 4.0V
EN to GND	-0.3V to 4.0V
RFIN, RFOUT to GND	-0.3V to 0.3V
Supply Maximum Current, I_{VDD}	30mA
RF Input Power, P_{IN}	10dBm
Junction Temperature	+150°C
Storage Temperature Range	-55°C to +150°C
Lead Temperature (Soldering, 10s)	+260°C
ESD Susceptibility ^{(1) (2)}	
HBM	±1500V
CDM	±2000V

NOTES:

1. For human body model (HBM), all pins comply with ANSI/ESDA/JEDEC JS-001 specifications.
2. For charged device model (CDM), all pins comply with ANSI/ESDA/JEDEC JS-002 specifications.

RECOMMENDED OPERATING CONDITIONS

Operating Frequency Range, f_0	1800MHz to 2200MHz
Operating Temperature Range	-40°C to +85°C
Supply Voltage Range, V_{DD}	1.5V to 3.6V
Control Voltage High, V_{CTL_H}	1.35V to V_{DD}
Control Voltage Low, V_{CTL_L}	0V to 0.45V

OVERSTRESS CAUTION

Stresses beyond those listed in Absolute Maximum Ratings may cause permanent damage to the device. Exposure to absolute maximum rating conditions for extended periods may affect reliability. Functional operation of the device at any conditions beyond those indicated in the Recommended Operating Conditions section is not implied.

ESD SENSITIVITY CAUTION

This integrated circuit can be damaged if ESD protections are not considered carefully. SGMICRO recommends that all integrated circuits be handled with appropriate precautions. Failure to observe proper handling and installation procedures can cause damage. ESD damage can range from subtle performance degradation to complete device failure. Precision integrated circuits may be more susceptible to damage because even small parametric changes could cause the device not to meet the published specifications.

DISCLAIMER

SG Micro Corp reserves the right to make any change in circuit design, or specifications without prior notice.

PIN CONFIGURATION

(TOP VIEW)

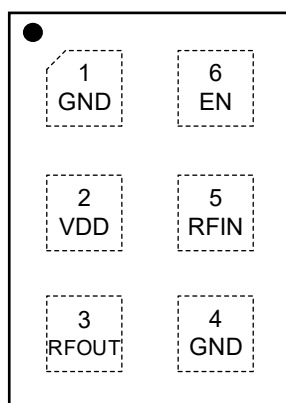

UTDFN-1.1×0.7-6L

PIN DESCRIPTION

PIN	NAME	FUNCTION
1, 4	GND	Ground.
2	VDD	Power Supply.
3	RFOUT	LNA Output.
5	RFIN	LNA Input from Antenna.
6	EN	Active High Enable Input for the Device. Pull high to LNA mode, pull low into bypass mode.

ELECTRICAL CHARACTERISTICS

($T_A = +25^\circ\text{C}$, $V_{DD} = 1.5\text{V}$ to 3.6V , $f_0 = 1800\text{MHz}$ to 2200MHz , typical values are at $V_{DD} = 2.8\text{V}$, input and output resistance = 50Ω , unless otherwise noted.)

PARAMETER	SYMBOL	CONDITIONS	MIN	TYP	MAX	UNITS
DC Characteristics						
Supply Voltage	V_{DD}		1.5		3.6	V
Supply Current	I_{VDD}	EN = High		5.8	7.2	mA
Control Voltage	V_{CTL_H}	High	0.8	1.8	V_{DD}	V
	V_{CTL_L}	Low	0	0	0.45	
RF Characteristics						
Power Gain	G	$f_0 = 1800\text{MHz} \sim 2200\text{MHz}$	12.4	14.1	15.6	dB
		$f_0 = 1800\text{MHz} \sim 2000\text{MHz}$	12.4	13.7	15.6	
		$f_0 = 2000\text{MHz} \sim 2200\text{MHz}$	12.8	13.9	15.6	
Input Return Loss	RL_I	$f_0 = 1800\text{MHz} \sim 2200\text{MHz}$	4.9 ⁽¹⁾	8.6		dB
		$f_0 = 1800\text{MHz} \sim 2000\text{MHz}$	4.9 ⁽¹⁾	8.1		
		$f_0 = 2000\text{MHz} \sim 2200\text{MHz}$	6.9 ⁽¹⁾	8.9		
Output Return Loss	RL_O	$f_0 = 1800\text{MHz} \sim 2200\text{MHz}$	6.0 ⁽¹⁾	12.6		dB
		$f_0 = 1800\text{MHz} \sim 2000\text{MHz}$	7.0 ⁽¹⁾	10.3		
		$f_0 = 2000\text{MHz} \sim 2200\text{MHz}$	6.0 ⁽¹⁾	9.5		
Reverse Isolation	ISO	$f_0 = 1800\text{MHz} \sim 2200\text{MHz}$	27.0 ⁽¹⁾	31.0		dB
		$f_0 = 1800\text{MHz} \sim 2000\text{MHz}$	27.8 ⁽¹⁾	31.2		
		$f_0 = 2000\text{MHz} \sim 2200\text{MHz}$	27.0 ⁽¹⁾	31.1		
Noise Figure	NF	$f_0 = 1800\text{MHz} \sim 2200\text{MHz}$		1.0	1.3 ⁽¹⁾	dB
		$f_0 = 1800\text{MHz} \sim 2000\text{MHz}$		1.0	1.2 ⁽¹⁾	
		$f_0 = 2000\text{MHz} \sim 2200\text{MHz}$		1.1	1.3 ⁽¹⁾	
Input Power 1dB Compression Point	P_{1dB}	$f_0 = 1800\text{MHz}$	-12.4 ⁽¹⁾	-10.4		dBm
		$f_0 = 2000\text{MHz}$	-11.1 ⁽¹⁾	-9.1		
		$f_0 = 2200\text{MHz}$	-10.4 ⁽¹⁾	-8.4		
Input In-Band IP3	IIP3_ib	$f_1 = 1800\text{MHz}$, $f_2 = 1801\text{MHz}$, $P_1 = P_2 = -25\text{dBm}$	-3.7 ⁽¹⁾	1.3		dBm
		$f_1 = 2000\text{MHz}$, $f_2 = 2001\text{MHz}$, $P_1 = P_2 = -25\text{dBm}$	-3.0 ⁽¹⁾	2.0		
		$f_1 = 2200\text{MHz}$, $f_2 = 2201\text{MHz}$, $P_1 = P_2 = -25\text{dBm}$	-2.7 ⁽¹⁾	2.3		
Turn-On Time	t_{ON}	Time from EN on to 90% of the gain		1.0	1.2	μs
Turn-Off Time	t_{OFF}	Time from EN off to 10% of the gain		0.06	0.50	μs
Bypass Mode						
Supply Current	I_{VDD}	$V_{EN} < 0.45\text{V}$		0.2	1	μA
Insertion Loss	IL	$f_0 = 1800\text{MHz} \sim 2200\text{MHz}$		4.4	5.9	dB
		$f_0 = 1800\text{MHz} \sim 2000\text{MHz}$		4.6	5.4	
		$f_0 = 2000\text{MHz} \sim 2200\text{MHz}$		4.8	5.9	
Input Return Loss	RL_I	$f_0 = 1800\text{MHz} \sim 2200\text{MHz}$	5.9 ⁽¹⁾	13.2		dB
		$f_0 = 1800\text{MHz} \sim 2000\text{MHz}$	10.3 ⁽¹⁾	14.7		
		$f_0 = 2000\text{MHz} \sim 2200\text{MHz}$	5.9 ⁽¹⁾	8.0		
Output Return Loss	RL_O	$f_0 = 1800\text{MHz} \sim 2200\text{MHz}$	5.6 ⁽¹⁾	10.9		dB
		$f_0 = 1800\text{MHz} \sim 2000\text{MHz}$	6.5 ⁽¹⁾	9.7		
		$f_0 = 2000\text{MHz} \sim 2200\text{MHz}$	5.6 ⁽¹⁾	8.7		

ELECTRICAL CHARACTERISTICS (continued)

($T_A = +25^\circ\text{C}$, $V_{DD} = 1.5\text{V}$ to 3.6V , $f_0 = 1800\text{MHz}$ to 2200MHz , typical values are at $V_{DD} = 1.8\text{V}$, input and output resistance = 50Ω , unless otherwise noted.)

PARAMETER	SYMBOL	CONDITIONS	MIN	TYP	MAX	UNITS
DC Characteristics						
Supply Voltage	V_{DD}		1.5	1.8	3.6	V
Supply Current	I_{VDD}	EN = High		5.9	7.3	mA
Control Voltage	V_{CTL_H}	High	0.8	1.8	V_{DD}	V
	V_{CTL_L}	Low	0	0	0.45	
RF Characteristics						
Power Gain	G	$f_0 = 1800\text{MHz} \sim 2200\text{MHz}$	12.5	14.1	15.6	dB
		$f_0 = 1800\text{MHz} \sim 2000\text{MHz}$	12.5	13.8	15.6	
		$f_0 = 2000\text{MHz} \sim 2200\text{MHz}$	12.8	13.8	15.6	
Input Return Loss	RL_I	$f_0 = 1800\text{MHz} \sim 2200\text{MHz}$	5.0 ⁽¹⁾	8.7		dB
		$f_0 = 1800\text{MHz} \sim 2000\text{MHz}$	5.0 ⁽¹⁾	8.3		
		$f_0 = 2000\text{MHz} \sim 2200\text{MHz}$	7.0 ⁽¹⁾	9.6		
Output Return Loss	RL_O	$f_0 = 1800\text{MHz} \sim 2200\text{MHz}$	5.2 ⁽¹⁾	12.6		dB
		$f_0 = 1800\text{MHz} \sim 2000\text{MHz}$	7.4 ⁽¹⁾	10.3		
		$f_0 = 2000\text{MHz} \sim 2200\text{MHz}$	5.2 ⁽¹⁾	9.5		
Reverse Isolation	ISO	$f_0 = 1800\text{MHz} \sim 2200\text{MHz}$	26.7 ⁽¹⁾	30.4		dB
		$f_0 = 1800\text{MHz} \sim 2000\text{MHz}$	27.2 ⁽¹⁾	30.9		
		$f_0 = 2000\text{MHz} \sim 2200\text{MHz}$	26.7 ⁽¹⁾	30.4		
Noise Figure	NF	$f_0 = 1800\text{MHz} \sim 2200\text{MHz}$		1.0	1.3 ⁽¹⁾	dB
		$f_0 = 1800\text{MHz} \sim 2000\text{MHz}$		1.0	1.2 ⁽¹⁾	
		$f_0 = 2000\text{MHz} \sim 2200\text{MHz}$		1.1	1.3 ⁽¹⁾	
Input Power 1dB Compression Point	P_{1dB}	$f_0 = 1800\text{MHz}$	-13.8 ⁽¹⁾	-11.8		dBm
		$f_0 = 2000\text{MHz}$	-13.0 ⁽¹⁾	-11.0		
		$f_0 = 2200\text{MHz}$	-12.6 ⁽¹⁾	-10.6		
Input In-Band IP3	IIP3_ib	$f_1 = 1800\text{MHz}$, $f_2 = 1801\text{MHz}$, $P_1 = P_2 = -25\text{dBm}$	-3.6 ⁽¹⁾	1.4		dBm
		$f_1 = 2000\text{MHz}$, $f_2 = 2001\text{MHz}$, $P_1 = P_2 = -25\text{dBm}$	-3.6 ⁽¹⁾	1.4		
		$f_1 = 2200\text{MHz}$, $f_2 = 2201\text{MHz}$, $P_1 = P_2 = -25\text{dBm}$	-3.1 ⁽¹⁾	1.9		
Turn-On Time	t_{ON}	Time from EN on to 90% of the gain		1.2	1.4	μs
Turn-Off Time	t_{OFF}	Time from EN off to 10% of the gain		0.09	0.50	μs
Bypass Mode						
Supply Current	I_{VDD}	$V_{EN} < 0.45\text{V}$		0.2	1	μA
Insertion Loss	IL	$f_0 = 1800\text{MHz} \sim 2200\text{MHz}$		4.8	5.5	dB
		$f_0 = 1800\text{MHz} \sim 2000\text{MHz}$		5.0	5.5	
		$f_0 = 2000\text{MHz} \sim 2200\text{MHz}$		5.2	5.5	
Input Return Loss	RL_I	$f_0 = 1800\text{MHz} \sim 2200\text{MHz}$	6.1 ⁽¹⁾	13.5		dB
		$f_0 = 1800\text{MHz} \sim 2000\text{MHz}$	10.6 ⁽¹⁾	14.9		
		$f_0 = 2000\text{MHz} \sim 2200\text{MHz}$	6.1 ⁽¹⁾	8.2		
Output Return Loss	RL_O	$f_0 = 1800\text{MHz} \sim 2200\text{MHz}$	5.5 ⁽¹⁾	11.1		dB
		$f_0 = 1800\text{MHz} \sim 2000\text{MHz}$	6.8 ⁽¹⁾	10.1		
		$f_0 = 2000\text{MHz} \sim 2200\text{MHz}$	5.5 ⁽¹⁾	8.7		

NOTE:

1. Guaranteed by design, not tested in production.

TYPICAL APPLICATION CIRCUIT

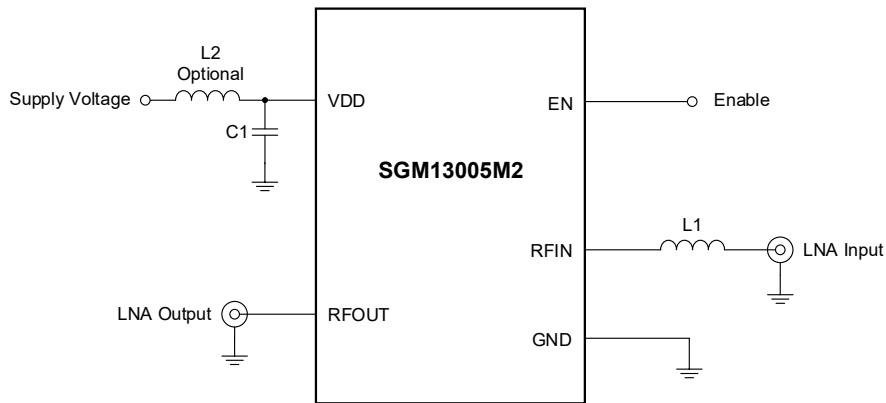

Figure 2. SGM13005M2 Typical Application Circuit

Table 1. Inductor Selection Table

Part	Typical (nH)	Q (min)	Frequency (MHz)	MFR	Size
LQW15A	6.8	25	250	Murata	0402

Table 2. Capacitor Selection Table

Part	Typical (pF)	Voltage (V)	MFR	Size
GRM155	1000	50	Murata	0402

EVALUATION BOARD LAYOUT

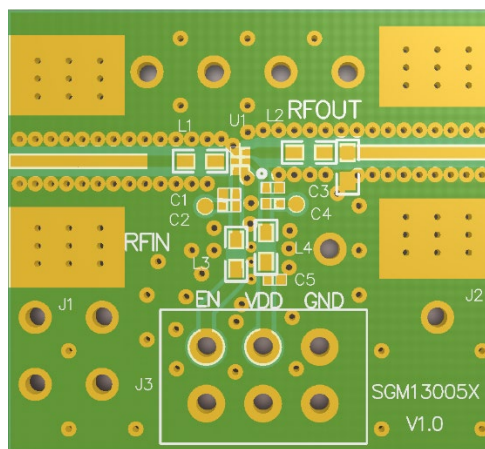

Figure 3. Evaluation Board Layout

REVISION HISTORY

NOTE: Page numbers for previous revisions may differ from page numbers in the current version.

SEPTEMBER 2025 – REV.A.3 to REV.A.4	Page
Updated Package Outline Dimensions.....	8
<hr/>	
APRIL 2024 – REV.A.2 to REV.A.3	Page
Updated Electrical Characteristics section.....	4, 5
<hr/>	
JUNE 2023 – REV.A.1 to REV.A.2	Page
Updated Electrical Characteristics section.....	4, 5
<hr/>	
MAY 2023 – REV.A to REV.A.1	Page
Updated Electrical Characteristics section.....	4, 5
<hr/>	
Changes from Original (DECEMBER 2022) to REV.A	Page
Changed from product preview to production data.....	All

PACKAGE INFORMATION

PACKAGE OUTLINE DIMENSIONS

UTDFN-1.1×0.7-6L

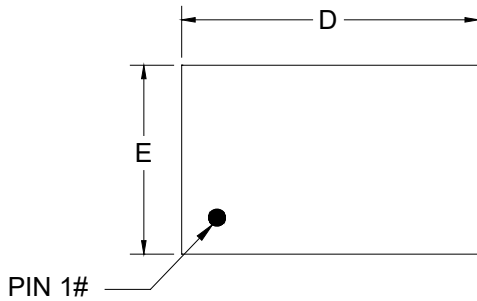

TOP VIEW

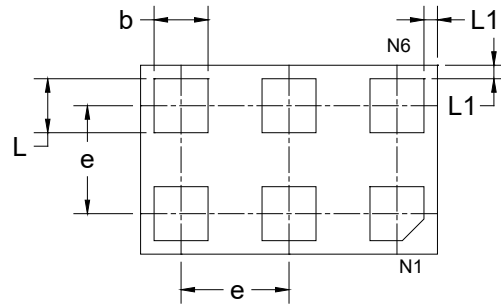

BOTTOM VIEW

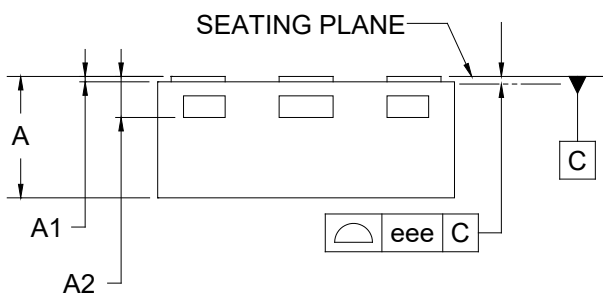

SIDE VIEW

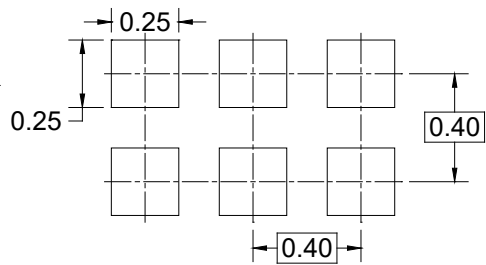

RECOMMENDED LAND PATTERN (Unit: mm)

Symbol	Dimensions In Millimeters		
	MIN	NOM	MAX
A	0.400	-	0.500
A1	0.000	-	0.050
A2	0.152 REF		
b	0.150	-	0.250
D	1.050	-	1.150
E	0.650	-	0.750
e	0.400 BSC		
L	0.150	-	0.250
L1	0.000	-	0.100
eee	0.080		

NOTE: This drawing is subject to change without notice.

TAPE AND REEL INFORMATION

REEL DIMENSIONS

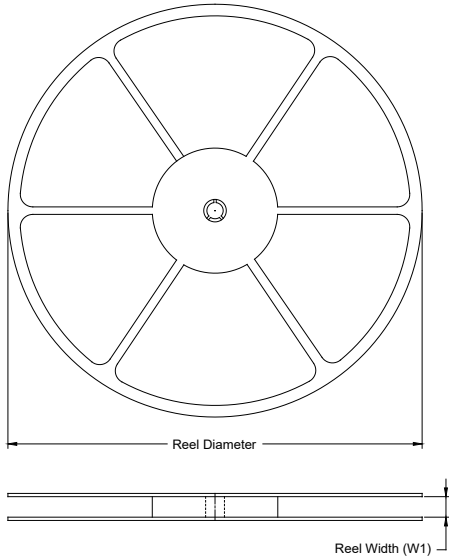

TAPE DIMENSIONS

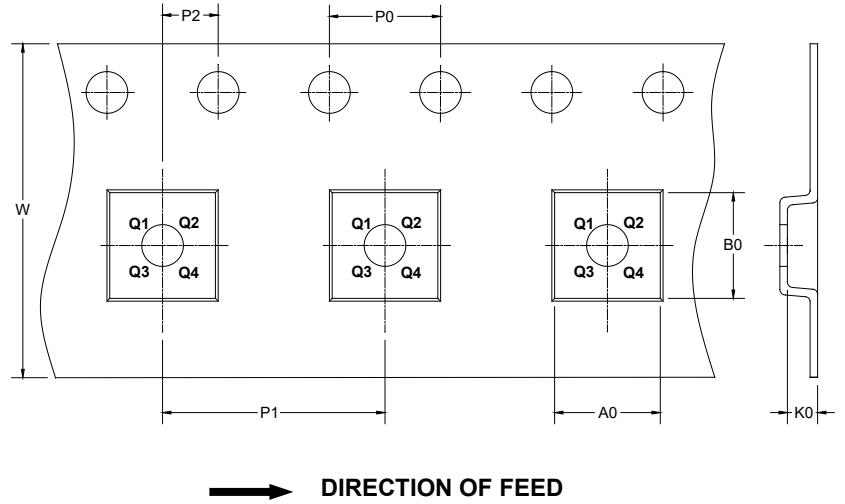

NOTE: The picture is only for reference. Please make the object as the standard.

KEY PARAMETER LIST OF TAPE AND REEL

Package Type	Reel Diameter	Reel Width W1 (mm)	A0 (mm)	B0 (mm)	K0 (mm)	P0 (mm)	P1 (mm)	P2 (mm)	W (mm)	Pin1 Quadrant
UTDFN-1.1×0.7-6L	7"	9.5	0.80	1.20	0.55	4.0	2.0	2.0	8.0	Q1

DD0001

PACKAGE INFORMATION

CARTON BOX DIMENSIONS

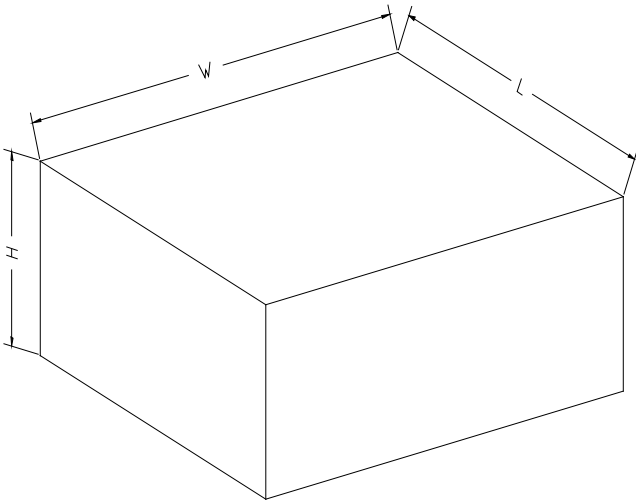

NOTE: The picture is only for reference. Please make the object as the standard.

KEY PARAMETER LIST OF CARTON BOX

Reel Type	Length (mm)	Width (mm)	Height (mm)	Pizza/Carton
7" (Option)	368	227	224	8
7"	442	410	224	18

D00002