

### GENERAL DESCRIPTION

The 74AHCT541 is an octal buffer/line driver with 3-state outputs, which can accept supply voltage range from 2.0V to 5.5V.

The 3-state control gate is a two-input AND gate with active-low inputs.  $\overline{OE1}$  and  $\overline{OE2}$  are two output enable inputs. When  $\overline{OE1}$  and  $\overline{OE2}$  are low, data transmits from An inputs to the Yn outputs. When  $\overline{OE1}$  or  $\overline{OE2}$  is high, all outputs are in high-impedance state.

The 74AHCT541 is available in Green SOIC-20 and TSSOP-20 packages. It operates over a temperature range of -40°C to +125°C.

### FUNCTION TABLE

INPUT			OUTPUT
$\overline{OE1}$	$\overline{OE2}$	An	Yn
L	L	L	L
L	L	H	H
H	X	X	Z
X	H	X	Z

H = High Voltage Level

L = Low Voltage Level

Z = High-Impedance State

X = Don't Care

### FEATURES

- **Wide Supply Voltage Range: 2.0V to 5.5V**
- **Inputs Accept Voltages Higher than the Supply Voltage and up to 5.5V**
- **3-State Buffers**
- **-40°C to +125°C Operating Temperature Range**
- **Available in Green SOIC-20 and TSSOP-20 Packages**

### APPLICATIONS

- Mother Board for Server, PC and Notebook Pad
- Telecom Equipment
- LED Display
- Industrial/Medical Equipment

### LOGIC DIAGRAM

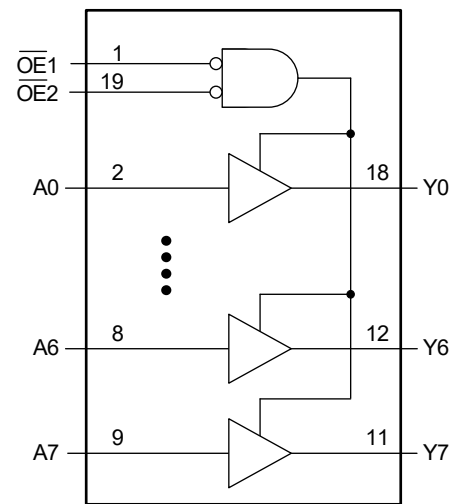

## PACKAGE/ORDERING INFORMATION

MODEL	PACKAGE DESCRIPTION	SPECIFIED TEMPERATURE RANGE	ORDERING NUMBER	PACKAGE MARKING	PACKING OPTION
74AHCT541	SOIC-20	-40°C to +125°C	74AHCT541XS20G/TR	74AHCT541XS20 XXXXX	Tape and Reel, 1500
	TSSOP-20	-40°C to +125°C	74AHCT541XTS20G/TR	2TJXTS20 XXXXX	Tape and Reel, 4000

## MARKING INFORMATION

NOTE: XXXXX = Date Code, Trace Code and Vendor Code.

**XXXXX**

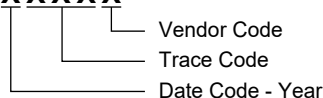

Green (RoHS & HSF): SG Micro Corp defines "Green" to mean Pb-Free (RoHS compatible) and free of halogen substances. If you have additional comments or questions, please contact your SGMICRO representative directly.

## ABSOLUTE MAXIMUM RATINGS

Supply Voltage Range, $V_{CC}$ .....	-0.5V to 7.0V
Input Voltage Range, $V_I$ <sup>(1)</sup> .....	-0.5V to 7.0V
Output Voltage Range, $V_O$ <sup>(1)</sup> .....	-0.5V to MIN(7.0V, $V_{CC} + 0.5V$ )
Input Clamp Current, $I_{IK}$ ( $V_I < 0V$ ) .....	-20mA
Output Clamp Current, $I_{OK}$ ( $V_O < 0V$ or $V_O > V_{CC}$ ) .....	$\pm 20mA$
Continuous Output Current, $I_O$ ( $V_O < 0V$ to $V_{CC}$ ) .....	$\pm 25mA$
Continuous Current through $V_{CC}$ or GND .....	$\pm 75mA$
Junction Temperature <sup>(2)</sup> .....	+150°C
Storage Temperature Range .....	-65°C to +150°C
Lead Temperature (Soldering, 10s) .....	+260°C
ESD Susceptibility <sup>(3) (4)</sup> .....	
HBM .....	$\pm 3000V$
CDM .....	$\pm 1000V$

## NOTES:

1. The input and output voltage ratings may be exceeded if the input and output clamp current ratings are observed.
2. The performance capability of a high-performance integrated circuit in conjunction with its thermal environment can create junction temperatures which are detrimental to reliability.
3. For human body model (HBM), all pins comply with ANSI/ESDA/JEDEC JS-001 specifications.
4. For charged device model (CDM), all pins comply with ANSI/ESDA/JEDEC JS-002 specifications.

## RECOMMENDED OPERATING CONDITIONS

Supply Voltage Range, $V_{CC}$ .....	2.0V to 5.5V
Input Voltage Range, $V_I$ .....	0V to 5.5V
Output Voltage Range, $V_O$ .....	0V to $V_{CC}$
Input Transition Rise or Fall Rate, $\Delta t/\Delta V$	
$V_{CC} = 3.3V \pm 0.3V$ .....	100ns/V (MAX)
$V_{CC} = 5.0V \pm 0.5V$ .....	20ns/V (MAX)
Operating Temperature Range .....	-40°C to +125°C

## OVERSTRESS CAUTION

Stresses beyond those listed in Absolute Maximum Ratings may cause permanent damage to the device. Exposure to absolute maximum rating conditions for extended periods may affect reliability. Functional operation of the device at any conditions beyond those indicated in the Recommended Operating Conditions section is not implied.

## ESD SENSITIVITY CAUTION

This integrated circuit can be damaged if ESD protections are not considered carefully. SGMICRO recommends that all integrated circuits be handled with appropriate precautions. Failure to observe proper handling and installation procedures can cause damage. ESD damage can range from subtle performance degradation to complete device failure. Precision integrated circuits may be more susceptible to damage because even small parametric changes could cause the device not to meet the published specifications.

## DISCLAIMER

SG Micro Corp reserves the right to make any change in circuit design, or specifications without prior notice.

## PIN CONFIGURATIONS

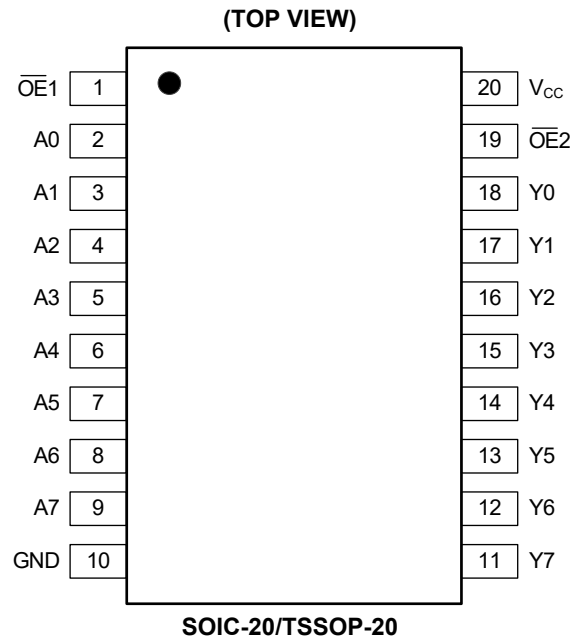

## PIN DESCRIPTION

PIN	NAME	FUNCTION
1, 19	$\overline{OE}1$ , $\overline{OE}2$	Output Enable Inputs (Active-Low).
2, 3, 4, 5, 6, 7, 8, 9	A0, A1, A2, A3, A4, A5, A6, A7	Data Inputs.
18, 17, 16, 15, 14, 13, 12, 11	Y0, Y1, Y2, Y3, Y4, Y5, Y6, Y7	Data Outputs.
10	GND	Ground.
20	V <sub>CC</sub>	Supply Voltage.

**ELECTRICAL CHARACTERISTICS**(Full = -40°C to +125°C, all typical values are measured at  $T_A = +25^\circ\text{C}$ , unless otherwise noted.)

PARAMETER	SYMBOL	CONDITIONS	TEMP	MIN	TYP	MAX	UNITS
High-Level Input Voltage	$V_{IH}$	$V_{CC} = 2.0\text{V}$	Full	1.2			V
		$V_{CC} = 3.0\text{V}$	Full	1.5			
		$V_{CC} = 5.5\text{V}$	Full	2.0			
Low-Level Input Voltage	$V_{IL}$	$V_{CC} = 2.0\text{V}$	Full			0.4	V
		$V_{CC} = 3.0\text{V}$	Full			0.6	
		$V_{CC} = 5.5\text{V}$	Full			0.8	
High-Level Output Voltage	$V_{OH}$	$V_{CC} = 2.0\text{V}, I_{OH} = -50\mu\text{A}$	Full	1.9	1.99		V
		$V_{CC} = 3.0\text{V}, I_{OH} = -50\mu\text{A}$	Full	2.9	2.99		
		$V_{CC} = 4.5\text{V}, I_{OH} = -50\mu\text{A}$	Full	4.4	4.49		
		$V_{CC} = 4.5\text{V}, I_{OH} = -8.0\text{mA}$	Full	4.0	4.25		
Low-Level Output Voltage	$V_{OL}$	$V_{CC} = 2.0\text{V}, I_{OL} = 50\mu\text{A}$	Full		0.01	0.1	V
		$V_{CC} = 3.0\text{V}, I_{OL} = 50\mu\text{A}$	Full		0.01	0.1	
		$V_{CC} = 4.5\text{V}, I_{OL} = 50\mu\text{A}$	Full		0.01	0.1	
		$V_{CC} = 4.5\text{V}, I_{OL} = 8.0\text{mA}$	Full		0.25	0.5	
Input Leakage Current	$I_I$	$V_{CC} = 0\text{V to } 5.5\text{V}, V_I = 5.5\text{V or GND}$	Full		$\pm 0.02$	$\pm 1$	$\mu\text{A}$
Off-State Output Current <sup>(1)</sup>	$I_{OZ}$	$V_{CC} = 5.5\text{V}, V_I = V_{IH} \text{ or } V_{IL}, V_O = V_{CC} \text{ or GND}$	Full		$\pm 0.02$	$\pm 2$	$\mu\text{A}$
Supply Current	$I_{CC}$	$V_{CC} = 5.5\text{V}, V_I = V_{CC} \text{ or GND}, I_O = 0\text{A}$	Full		0.02	10	$\mu\text{A}$
Input Capacitance	$C_I$	$V_{CC} = 5.0\text{V}$	+25°C		4.0		pF
Output Capacitance	$C_O$	$V_{CC} = 5.0\text{V}$	+25°C		4.5		pF

## NOTE:

1. For I/O ports, the parameter  $I_{OZ}$  includes the input leakage current.

**DYNAMIC CHARACTERISTICS**

(See Figure 1 for test circuit. Full = -40°C to +125°C, all typical values are measured at  $T_A = +25^\circ\text{C}$  and  $V_{CC} = 3.3\text{V}$  and  $5.0\text{V}$  respectively, unless otherwise noted.)

PARAMETER	SYMBOL	CONDITIONS		TEMP	MIN <sup>(1)</sup>	TYP	MAX <sup>(1)</sup>	UNITS
Propagation Delay <sup>(2)</sup>	$t_{PD}$	An to Yn, $V_{CC} = 3.3\text{V} \pm 0.3\text{V}$	$C_L = 15\text{pF}$	Full	0.5	7.0	11.5	ns
			$C_L = 50\text{pF}$	Full	0.5	8.5	14.0	
		An to Yn, $V_{CC} = 5.0\text{V} \pm 0.5\text{V}$	$C_L = 15\text{pF}$	Full	0.5	5.5	8.5	
			$C_L = 50\text{pF}$	Full	0.5	6.5	10.5	
Enable Time <sup>(2)</sup>	$t_{EN}$	$\overline{OEn}$ to Yn, $V_{CC} = 3.3\text{V} \pm 0.3\text{V}$	$C_L = 15\text{pF}$	Full	0.5	12.0	18.5	ns
			$C_L = 50\text{pF}$	Full	1.0	13.0	21.0	
		$\overline{OEn}$ to Yn, $V_{CC} = 5.0\text{V} \pm 0.5\text{V}$	$C_L = 15\text{pF}$	Full	0.5	9.0	13.5	
			$C_L = 50\text{pF}$	Full	1.0	10.0	15.5	
Disable Time <sup>(2)</sup>	$t_{DIS}$	$\overline{OEn}$ to Yn, $V_{CC} = 3.3\text{V} \pm 0.3\text{V}$	$C_L = 15\text{pF}$	Full	1.0	8.5	12.0	ns
			$C_L = 50\text{pF}$	Full	1.0	15.5	22.0	
		$\overline{OEn}$ to Yn, $V_{CC} = 5.0\text{V} \pm 0.5\text{V}$	$C_L = 15\text{pF}$	Full	1.0	6.0	10.0	
			$C_L = 50\text{pF}$	Full	1.0	9.5	15.0	
Channel-to-Channel Skew	$t_{SKO}$	$V_{CC} = 3.3\text{V} \pm 0.3\text{V}$	$C_L = 50\text{pF}$	+25°C		500		ps
		$V_{CC} = 5.0\text{V} \pm 0.5\text{V}$	$C_L = 50\text{pF}$	+25°C		500		
Power Dissipation Capacitance <sup>(3)</sup>	$C_{PD}$	$V_{CC} = 5.0\text{V}$ , no load, $f = 1\text{MHz}$		+25°C		7.0		pF

## NOTES:

- Specified by design and characterization, not production tested.
- $t_{PD}$  is the same as  $t_{PLH}$  and  $t_{PHL}$ .  $t_{EN}$  is the same as  $t_{PZL}$  and  $t_{PZH}$ .  $t_{DIS}$  is the same as  $t_{PLZ}$  and  $t_{PHZ}$ .
- $C_{PD}$  is used to determine the dynamic power dissipation ( $P_D$  in  $\mu\text{W}$ ).

$$P_D = C_{PD} \times V_{CC}^2 \times f_i \times N + \Sigma(C_L \times V_{CC}^2 \times f_o)$$

where:

$f_i$  = Input frequency in MHz.

$f_o$  = Output frequency in MHz.

$C_L$  = Output load capacitance in pF.

$V_{CC}$  = Supply voltage in Volts.

$N$  = Number of inputs switching.

$\Sigma(C_L \times V_{CC}^2 \times f_o)$  = Sum of the outputs.

TEST CIRCUIT

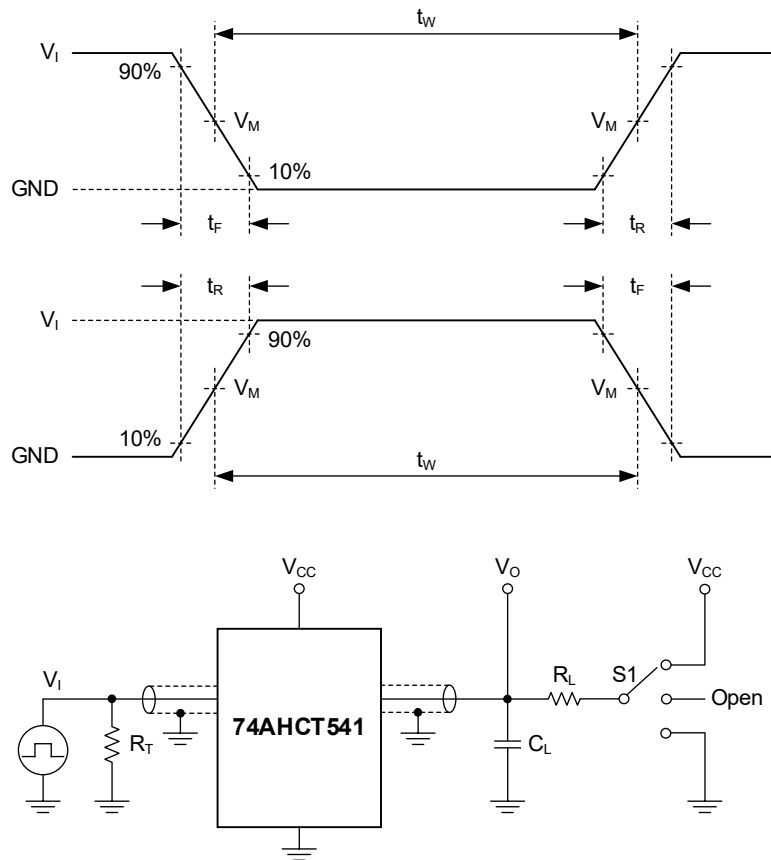

Test conditions are given in Table 1.

Definitions for test circuit:

$R_L$ : Load resistance.

$C_L$ : Load capacitance (includes jig and probe).

$R_T$ : Termination resistance (equals to output impedance  $Z_O$  of the pulse generator).

S1: Test selection switch.

Figure 1. Test Circuit for Measuring Switching Times

Table 1. Test Conditions

SUPPLY VOLTAGE	INPUT		LOAD		S1		
$V_{CC}$	$V_I$	$t_R, t_F$	$C_L$	$R_L$	$t_{PLH}, t_{PHL}$	$t_{PLZ}, t_{PZL}$	$t_{PHZ}, t_{PZH}$
2.0V to 5.5V	GND to $V_{CC}$	$\leq 3.0\text{ns}$	15pF, 50pF	1k $\Omega$	Open	$V_{CC}$	GND

WAVEFORMS

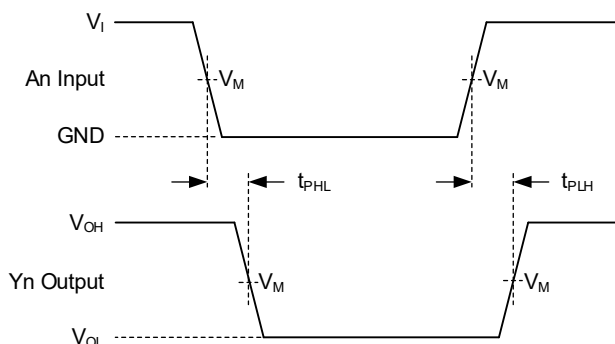

Test conditions are given in Table 1.

Measurement points are given in Table 2.

Logic levels:  $V_{OL}$  and  $V_{OH}$  are typical output voltage levels that occur with the output load.

Figure 2. Input (An) to Output (Yn) Propagation Delay Times

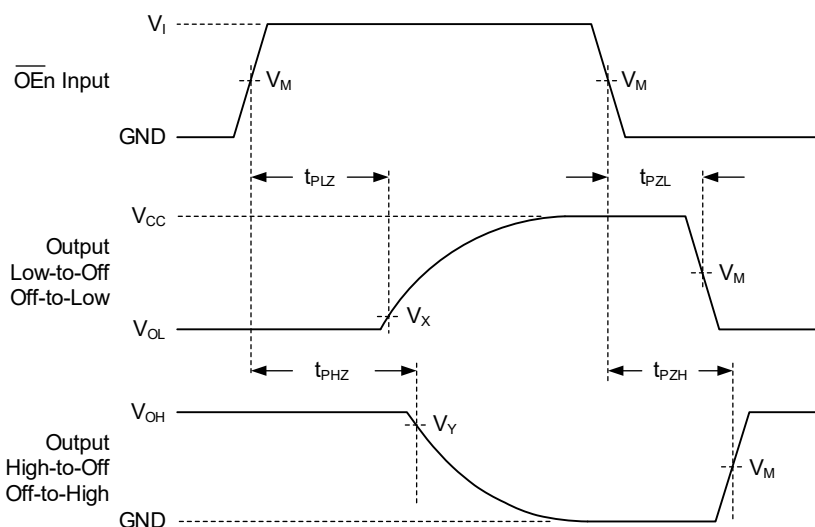

Test conditions are given in Table 1.

Measurement points are given in Table 2.

Logic levels:  $V_{OL}$  and  $V_{OH}$  are typical output voltage levels that occur with the output load.

Figure 3. Enable and Disable Times

Table 2. Measurement Points

SUPPLY VOLTAGE	INPUT		OUTPUT		
	$V_I$	$V_M^{(1)}$	$V_M$	$V_X$	$V_Y$
$V_{CC}$ 2.0V to 5.5V	$V_{CC}$	$0.5 \times V_{CC}$	$0.5 \times V_{CC}$	$V_{OL} + 0.3V$	$V_{OH} - 0.3V$

NOTE:

1. The measurement points should be  $V_{IH}$  or  $V_{IL}$  when the input rising or falling time exceeds 3.0ns.

## REVISION HISTORY

NOTE: Page numbers for previous revisions may differ from page numbers in the current version.

Changes from Original to REV.A (JUNE 2026)	Page
Changed from product preview to production data.....	All

---

## PACKAGE OUTLINE DIMENSIONS

### SOIC-20

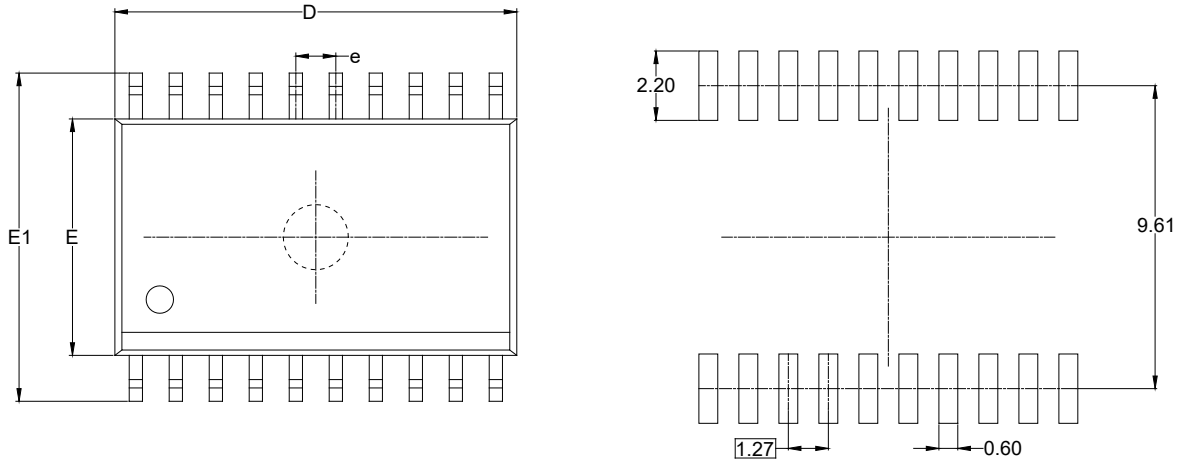

RECOMMENDED LAND PATTERN (Unit: mm)

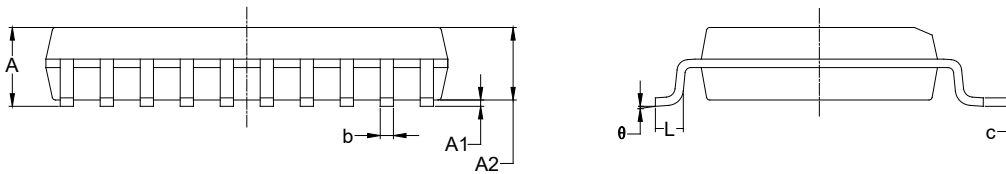

Symbol	Dimensions In Millimeters		Dimensions In Inches	
	MIN	MAX	MIN	MAX
A	2.350	2.650	0.093	0.104
A1	0.100	0.300	0.004	0.012
A2	2.100	2.500	0.083	0.098
b	0.330	0.510	0.013	0.020
c	0.204	0.330	0.008	0.013
D	12.520	13.000	0.493	0.512
E	7.400	7.600	0.291	0.299
E1	10.210	10.610	0.402	0.418
e	1.27 BSC		0.050 BSC	
L	0.400	1.270	0.016	0.050
θ	0°	8°	0°	8°

**NOTES:**

1. Body dimensions do not include mode flash or protrusion.
2. This drawing is subject to change without notice.

PACKAGE OUTLINE DIMENSIONS

TSSOP-20

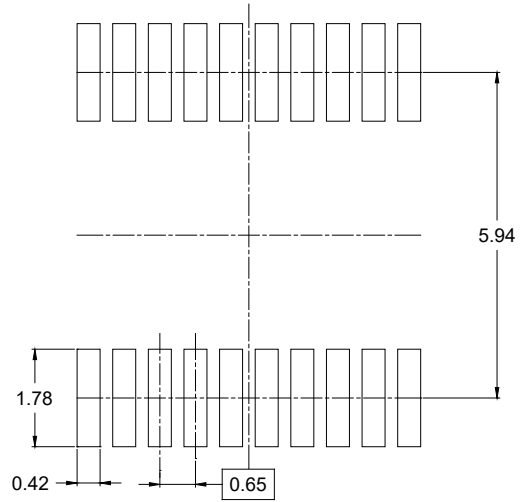
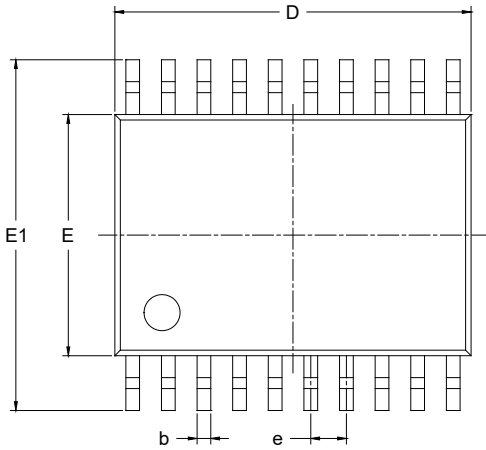

RECOMMENDED LAND PATTERN (Unit: mm)

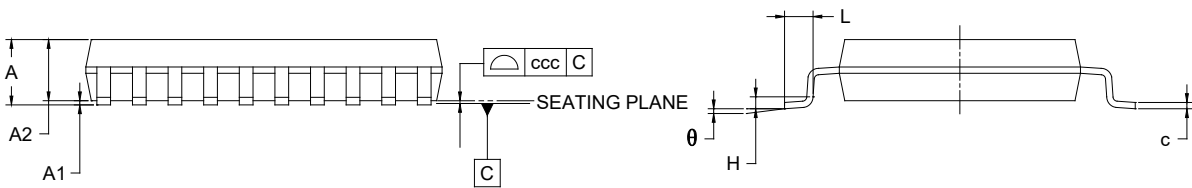

Symbol	Dimensions In Millimeters		
	MIN	NOM	MAX
A	-	-	1.200
A1	0.050	-	0.150
A2	0.800	-	1.050
b	0.190	-	0.300
c	0.090	-	0.200
D	6.400	-	6.600
E	4.300	-	4.500
E1	6.200	-	6.600
e	0.650 BSC		
L	0.450	-	0.750
H	0.250 TYP		
θ	0°	-	8°
ccc	0.100		

NOTES:

1. Body dimensions do not include mode flash or protrusion.
2. This drawing is subject to change without notice.
3. Reference JEDEC MO-153.

# PACKAGE INFORMATION

## TAPE AND REEL INFORMATION

### REEL DIMENSIONS

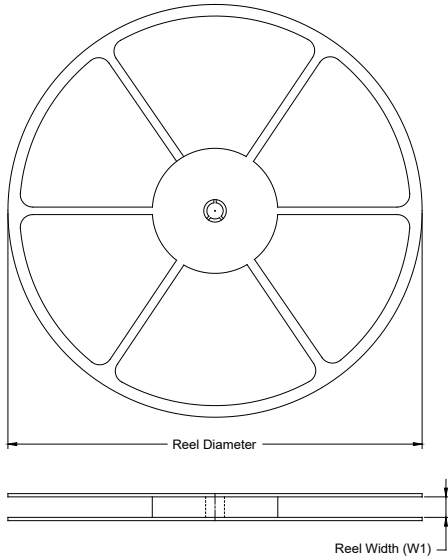

### TAPE DIMENSIONS

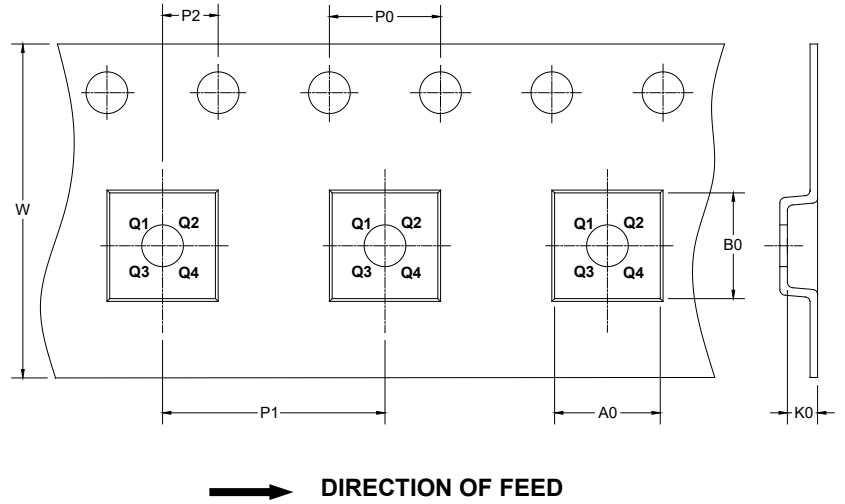

NOTE: The picture is only for reference. Please make the object as the standard.

### KEY PARAMETER LIST OF TAPE AND REEL

Package Type	Reel Diameter	Reel Width W1 (mm)	A0 (mm)	B0 (mm)	K0 (mm)	P0 (mm)	P1 (mm)	P2 (mm)	W (mm)	Pin1 Quadrant
SOIC-20	13"	24.4	10.90	13.30	3.00	4.0	12.0	2.0	24.0	Q1
TSSOP-20	13"	16.4	6.80	6.90	1.50	4.0	8.0	2.0	16.0	Q1

DD0001

# PACKAGE INFORMATION

## CARTON BOX DIMENSIONS

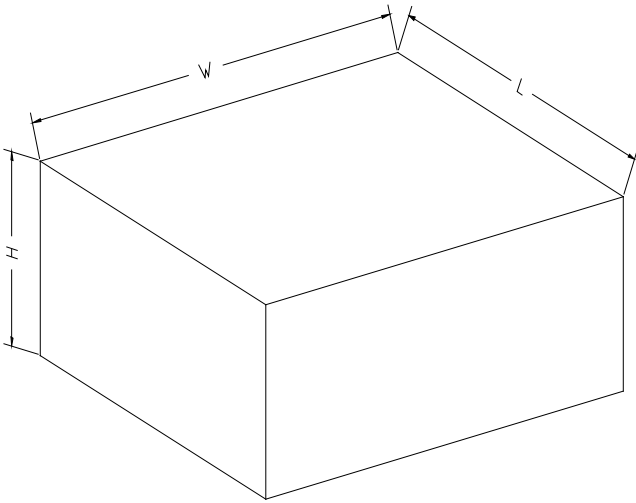

NOTE: The picture is only for reference. Please make the object as the standard.

## KEY PARAMETER LIST OF CARTON BOX

Reel Type	Length (mm)	Width (mm)	Height (mm)	Pizza/Carton
13"	386	280	370	5

DD0002