

### GENERAL DESCRIPTION

The dual SGM8754-2 and quad SGM8754-4 are rail-to-rail input, low voltage power supply comparators that can operate in the range of 2.7V to 5.5V. The two devices both have an open-drain output structure. They can be a good choice for applications with low power, low voltage operation and limited space sizes in PCB design.

The SGM8754-2 is available in Green SOIC-8 and MSOP-8 packages. The SGM8754-4 is available in Green SOIC-14, TSSOP-14 and UTQFN-2x2-14BL packages. They are rated over the -40°C to +125°C temperature range.

### FEATURES

- **Single-Supply Voltage Range:** 2.7V to 5.5V
- **Low Supply Current:**
  - ◆ 80µA (TYP) for SGM8754-2 at  $V_{CC} = 5V$
  - ◆ 160µA (TYP) for SGM8754-4 at  $V_{CC} = 5V$
- **Rail to Rail Input**
- **Input Common Mode Voltage Range:**  
GND - 0.1V to  $V_{CC} + 0.1V$
- **Open-Drain Output Structure**
- **Low Output Saturation Voltage:**  
55mV (TYP) at  $V_{CC} = 5V$
- **-40°C to +125°C Operating Temperature Range**
- **Small Packaging:**  
SGM8754-2 Available in Green SOIC-8 and MSOP-8 Packages  
SGM8754-4 Available in Green SOIC-14, TSSOP-14 and UTQFN-2x2-14BL Packages

### APPLICATIONS

- Window Comparators
- Hysteresis Comparators
- Oscillators
- Test Equipment
- Industrial Applications
- Measurements

### TYPICAL APPLICATION

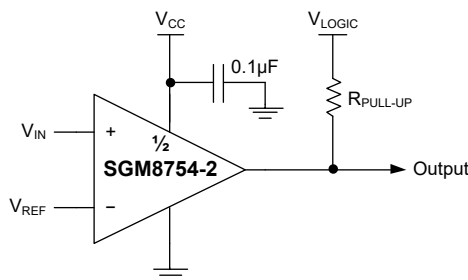

Figure 1. Typical Application Circuit

**PACKAGE/ORDERING INFORMATION**

MODEL	PACKAGE DESCRIPTION	SPECIFIED TEMPERATURE RANGE	ORDERING NUMBER	PACKAGE MARKING	PACKING OPTION
SGM8754-2	SOIC-8	-40°C to +125°C	SGM8754-2XS8G/TR	0C6XS8 XXXXX	Tape and Reel, 4000
	MSOP-8	-40°C to +125°C	SGM8754-2XMS8G/TR	0C7XMS8 XXXXX	Tape and Reel, 4000
SGM8754-4	SOIC-14	-40°C to +125°C	SGM8754-4XS14G/TR	SGM87544XS14 XXXXX	Tape and Reel, 2500
	TSSOP-14	-40°C to +125°C	SGM8754-4XTS14G/TR	SGM87544 XTS14 XXXXX	Tape and Reel, 4000
	UTQFN-2x2-14BL	-40°C to +125°C	SGM8754-4XUUG14G/TR	0C9 XXXX	Tape and Reel, 3000

**MARKING INFORMATION**

NOTE: XXXXX = Date Code, Trace Code and Vendor Code. XXXX = Date Code, Trace Code and Vendor Code.

**SOIC-8/MSOP-8/SOIC-14/TSSOP-14**

**XXXXX**

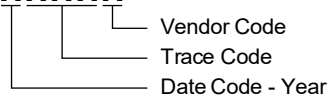

**UTQFN-2x2-14BL**

**YYY** — Serial Number  
**XXXX**

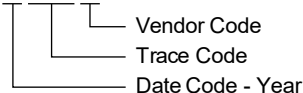

Green (RoHS & HSF): SG Micro Corp defines "Green" to mean Pb-Free (RoHS compatible) and free of halogen substances. If you have additional comments or questions, please contact your SGMICRO representative directly.

**ABSOLUTE MAXIMUM RATINGS**

Supply Voltage, $V_{CC}$ <sup>(1)</sup> .....	6V
Differential Input Voltage, $V_{ID}$ <sup>(2)</sup> .....	$\pm V_{CC}$
Input Voltage Range (Either Input), $V_{IN}$ .....	-0.3V to $V_{CC} + 0.3V$
Output Short-Circuit to GND Duration (One Comparator) <sup>(3)</sup>	
At or below $T_A = +25^{\circ}C$ , $V_{CC} \leq 5.5V$ .....	Unlimited
Package Thermal Resistance	
SOIC-8, $\theta_{JA}$ .....	162.1 $^{\circ}C/W$
SOIC-8, $\theta_{JB}$ .....	108.5 $^{\circ}C/W$
MSOP-8, $\theta_{JA}$ .....	180.6 $^{\circ}C/W$
MSOP-8, $\theta_{JB}$ .....	125.6 $^{\circ}C/W$
SOIC-14, $\theta_{JA}$ .....	98.6 $^{\circ}C/W$
SOIC-14, $\theta_{JB}$ .....	56.9 $^{\circ}C/W$
TSSOP-14, $\theta_{JA}$ .....	129.2 $^{\circ}C/W$
TSSOP-14, $\theta_{JB}$ .....	89.2 $^{\circ}C/W$
UTQFN-2x2-14BL, $\theta_{JA}$ .....	125.1 $^{\circ}C/W$
UTQFN-2x2-14BL, $\theta_{JB}$ .....	41.7 $^{\circ}C/W$
Junction Temperature.....	+150 $^{\circ}C$
Storage Temperature Range .....	-65 $^{\circ}C$ to +150 $^{\circ}C$
Lead Temperature (Soldering, 10s).....	+260 $^{\circ}C$
ESD Susceptibility <sup>(4) (5)</sup>	
HBM.....	$\pm 4000V$
CDM .....	$\pm 1000V$

NOTES:

1. All voltage values are related to the GND network, except for the differential voltages.
2. Differential voltage is between +IN and -IN.
3. When the output is short-circuited to power supply, the device can overheat and eventually be damaged.
4. For human body model (HBM), all pins comply with ANSI/ESDA/JEDEC JS-001 specifications.
5. For charged device model (CDM), all pins comply with ANSI/ESDA/JEDEC JS-002 specifications.

**RECOMMENDED OPERATING CONDITIONS**

Single Supply Voltage Range, $V_{CC}$ .....	2.7V to 5.5V
Operating Temperature Range .....	-40 $^{\circ}C$ to +125 $^{\circ}C$

**OVERSTRESS CAUTION**

Stresses beyond those listed in Absolute Maximum Ratings may cause permanent damage to the device. Exposure to absolute maximum rating conditions for extended periods may affect reliability. Functional operation of the device at any conditions beyond those indicated in the Recommended Operating Conditions section is not implied.

**ESD SENSITIVITY CAUTION**

This integrated circuit can be damaged if ESD protections are not considered carefully. SGMICRO recommends that all integrated circuits be handled with appropriate precautions. Failure to observe proper handling and installation procedures can cause damage. ESD damage can range from subtle performance degradation to complete device failure. Precision integrated circuits may be more susceptible to damage because even small parametric changes could cause the device not to meet the published specifications.

**DISCLAIMER**

SG Micro Corp reserves the right to make any change in circuit design, or specifications without prior notice.

**PIN CONFIGURATIONS**

**SGM8754-2 (TOP VIEW)**

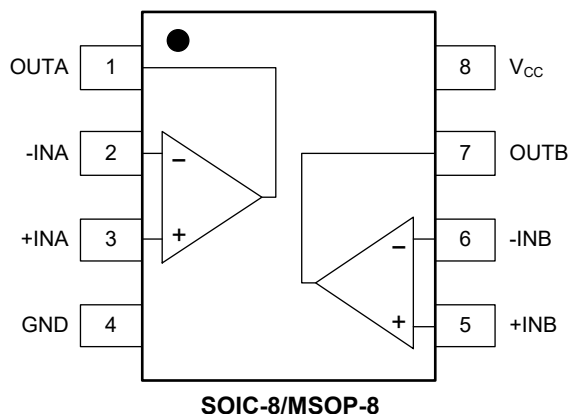

**SGM8754-4 (TOP VIEW)**

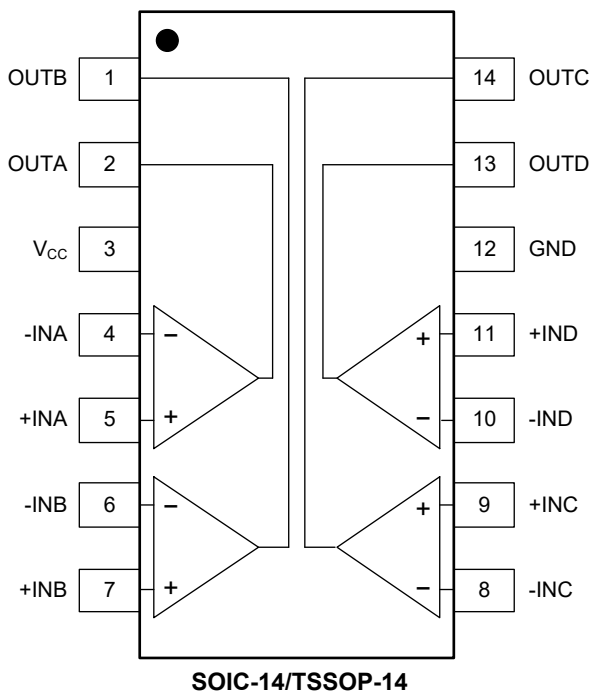

**SGM8754-4 (TOP VIEW)**

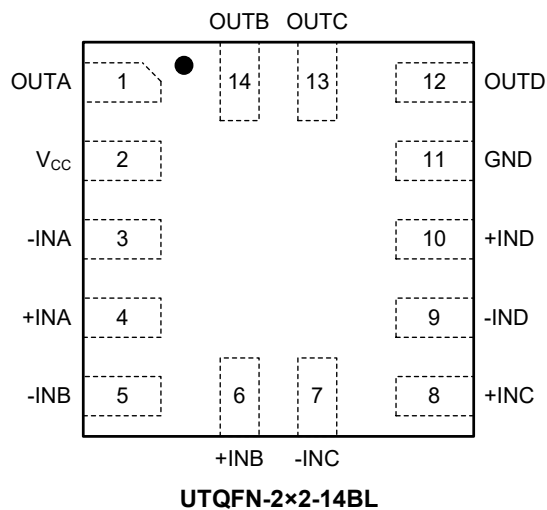

**PIN DESCRIPTION**

Table 1. SGM8754-2 Pin Description

PIN		NAME	TYPE	FUNCTION
SOIC-8/MSOP-8				
1, 7		OUTA, OUTB	O	Output.
2, 6		-INA, -INB	I	Inverting Input of Comparators.
3, 5		+INA, +INB	I	Non-Inverting Input of Comparators.
4		GND	—	Ground.
8		V <sub>CC</sub>	—	Power Supply.

Table 2. SGM8754-4 Pin Description

PIN		NAME	TYPE	FUNCTION
SOIC-14/ TSSOP-14	TQFN-2×2-14L			
1, 2, 13, 14	14, 1, 12, 13	OUTB, OUTA, OUTD, OUTC	O	Output.
3	2	V <sub>CC</sub>	—	Power Supply.
4, 6, 8, 10	3, 5, 7, 9	-INA, -INB, -INC, -IND	I	Inverting Input of Comparators.
5, 7, 9, 11	4, 6, 8, 10	+INA, +INB, +INC, +IND	I	Non-Inverting Input of Comparators.
12	11	GND	—	Ground.

**ELECTRICAL CHARACTERISTICS**

( $V_{CC} = 2.7V$ ,  $GND = 0V$ ,  $R_L = 5.1k\Omega$ , Full =  $-40^{\circ}C$  to  $+125^{\circ}C$ , typical values are at  $T_A = +25^{\circ}C$ , unless otherwise noted.)

PARAMETER	SYMBOL	CONDITIONS	TEMP	MIN	TYP	MAX	UNITS
Input Offset Voltage	$V_{OS}$	$V_{CM} = V_{CC}/2$	+25°C		±0.6	±3.4	mV
			Full			±3.6	
Input Offset Voltage Drift	$\Delta V_{OS}/\Delta T$		Full		1		$\mu V/^{\circ}C$
Input Bias Current	$I_B$	$V_{CM} = V_{CC}/2$	+25°C		±0.05	±0.45	nA
			Full			±5	
Input Offset Current	$I_{OS}$	$V_{CM} = V_{CC}/2$	+25°C		±0.05	±0.45	nA
			Full			±1	
Input Common Mode Voltage Range	$V_{CM}$		+25°C	GND - 0.1		$V_{CC} + 0.1$	V
Common Mode Rejection Ratio	CMRR	$V_{CM} = GND - 0.1V$ to $V_{CC} + 0.1V$	+25°C	56	73		dB
			Full	52			
Output Current (Sinking)	$I_{OUT}$	$V_{OUT} \leq 1.5V$	+25°C	33	48		mA
			Full	20			
Output Leakage Current			Full		0.01	1	$\mu A$
Saturation Voltage	$V_{SAT}$	$I_{OUT} \leq 1.5mA$	Full		28	55	mV
Supply Current	$I_{CC}$	For SGM8754-2	Full		70	100	$\mu A$
		For SGM8754-4	Full		145	200	

( $V_{CC} = 5V$ ,  $GND = 0V$ ,  $R_L = 5.1k\Omega$ , Full =  $-40^{\circ}C$  to  $+125^{\circ}C$ , typical values are at  $T_A = +25^{\circ}C$ , unless otherwise noted.)

PARAMETER	SYMBOL	CONDITIONS	TEMP	MIN	TYP	MAX	UNITS
Input Offset Voltage	$V_{OS}$	$V_{CM} = V_{CC}/2$	+25°C		±0.6	±3.4	mV
			Full			±3.6	
Input Offset Voltage Drift	$\Delta V_{OS}/\Delta T$		Full		1		$\mu V/^{\circ}C$
Input Bias Current	$I_B$	$V_{CM} = V_{CC}/2$	+25°C		±0.05	±0.45	nA
			Full			±5	
Input Offset Current	$I_{OS}$	$V_{CM} = V_{CC}/2$	+25°C		±0.05	±0.45	nA
			Full			±1	
Input Common Mode Voltage Range	$V_{CM}$		+25°C	GND - 0.1		$V_{CC} + 0.1$	V
Common Mode Rejection Ratio	CMRR	$V_{CM} = GND - 0.1V$ to $V_{CC} + 0.1V$	+25°C	60	78		dB
			Full	56			
Output Current (Sinking)	$I_{OUT}$	$V_{OUT} \leq 1.5V$	+25°C	67	95		mA
			Full	40			
Output Leakage Current			Full		0.01	1	$\mu A$
Large-Signal Differential Voltage Gain	$A_{VD}$		+25°C	28	100		V/mV
Saturation Voltage	$V_{SAT}$	$I_{OUT} \leq 4mA$	Full		55	120	mV
Supply Current	$I_{CC}$	For SGM8754-2	Full		80	115	$\mu A$
		For SGM8754-4	Full		160	230	

**SWITCHING CHARACTERISTICS**

( $V_{CC} = 2.7V$ ,  $GND = 0V$ ,  $R_L = 5.1k\Omega$ , Full =  $-40^{\circ}C$  to  $+125^{\circ}C$ , typical values are at  $T_A = +25^{\circ}C$ , unless otherwise noted.)

PARAMETER	SYMBOL	CONDITIONS	TEMP	MIN	TYP	MAX	UNITS
Propagation Delay (High to Low)	$t_{PHL}$	Input overdrive = 10mV	Full	150	400	550	ns
		Input overdrive = 100mV	Full	75	260	360	
Propagation Delay (Low to High)	$t_{PLH}$	Input overdrive = 10mV	Full	225	550	750	ns
		Input overdrive = 100mV	Full	125	350	450	

( $V_{CC} = 5V$ ,  $GND = 0V$ ,  $R_L = 5.1k\Omega$ , Full =  $-40^{\circ}C$  to  $+125^{\circ}C$ , typical values are at  $T_A = +25^{\circ}C$ , unless otherwise noted.)

PARAMETER	SYMBOL	CONDITIONS	TEMP	MIN	TYP	MAX	UNITS
Propagation Delay (High to Low)	$t_{PHL}$	Input overdrive = 10mV	Full	125	350	550	ns
		Input overdrive = 100mV	Full	60	250	330	
Propagation Delay (Low to High)	$t_{PLH}$	Input overdrive = 10mV	Full	190	470	700	ns
		Input overdrive = 100mV	Full	100	320	450	

**TYPICAL PERFORMANCE CHARACTERISTICS**

At  $T_A = +25^\circ\text{C}$ , unless otherwise noted.

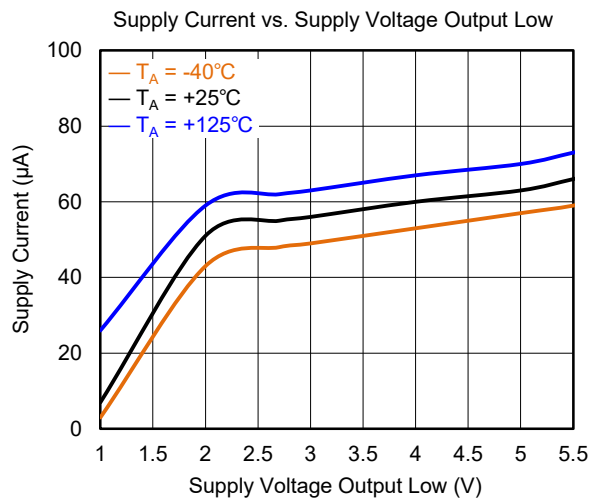
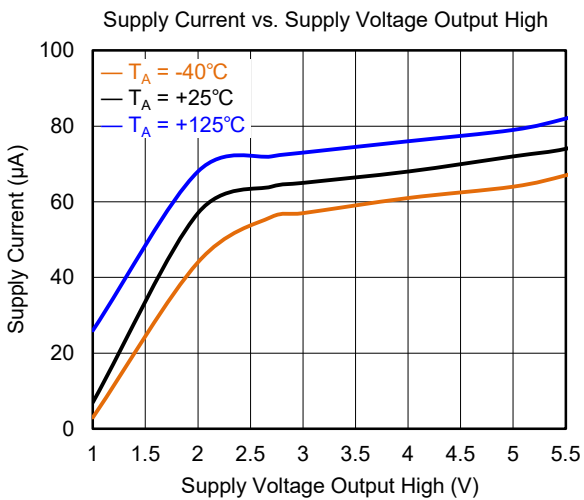
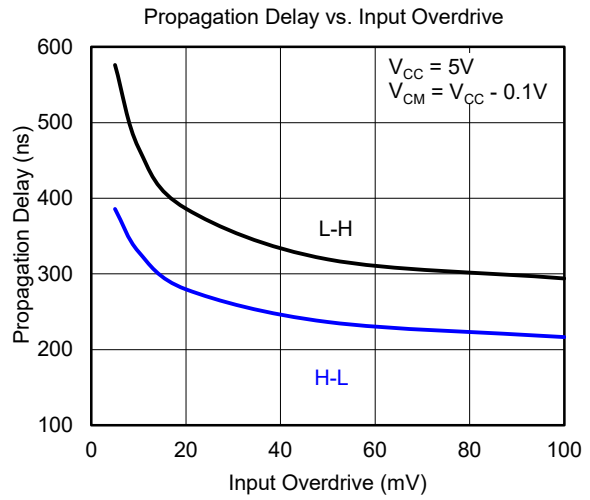
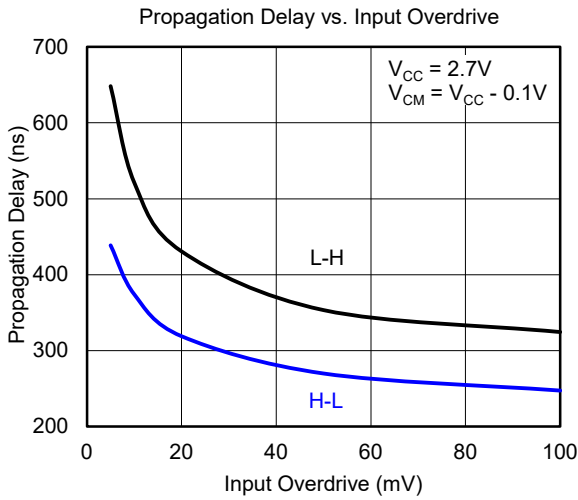
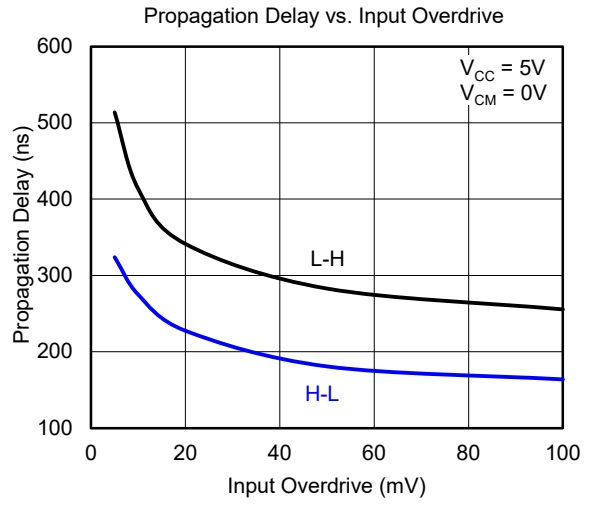
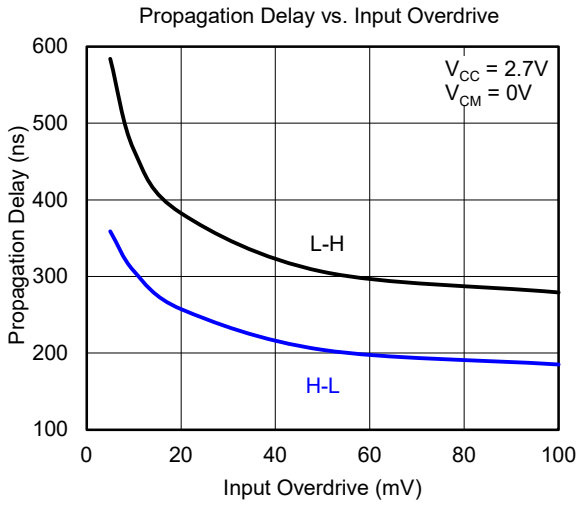

**TYPICAL PERFORMANCE CHARACTERISTICS (continued)**

At  $T_A = +25^\circ\text{C}$ , unless otherwise noted.

Input Bias Current vs. Supply Voltage

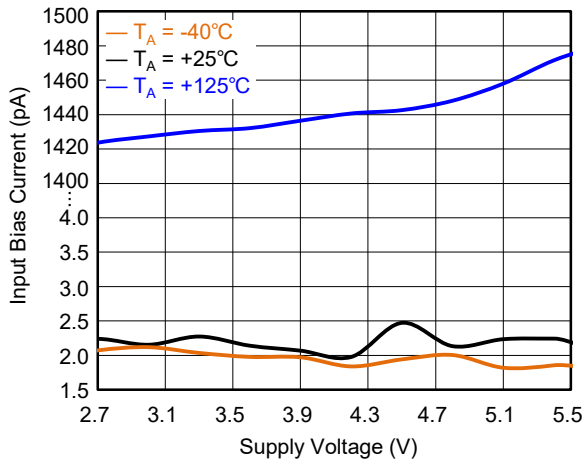

Output Voltage vs. Output Current

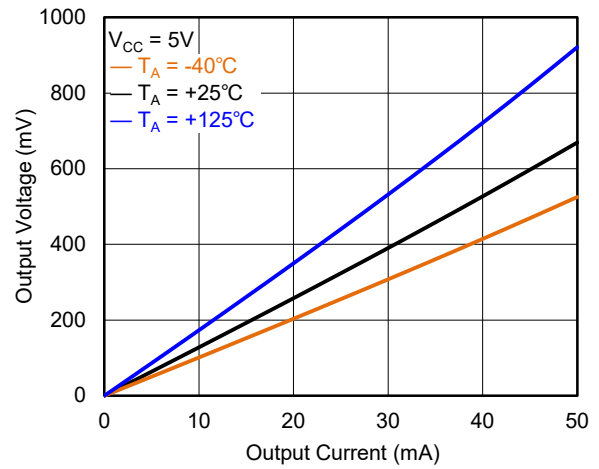

Input Offset Voltage vs. Input Common Mode Voltage

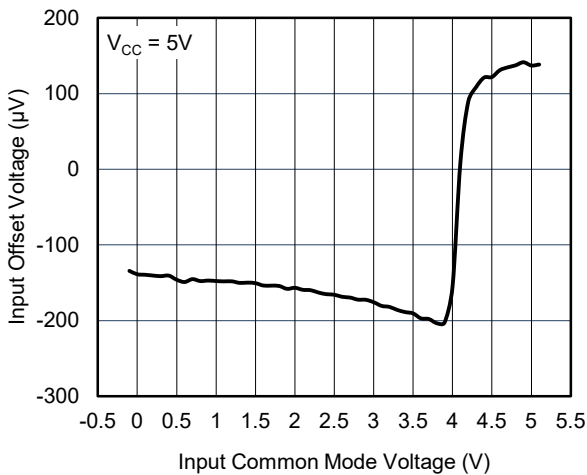

**FUNCTIONAL BLOCK DIAGRAM**

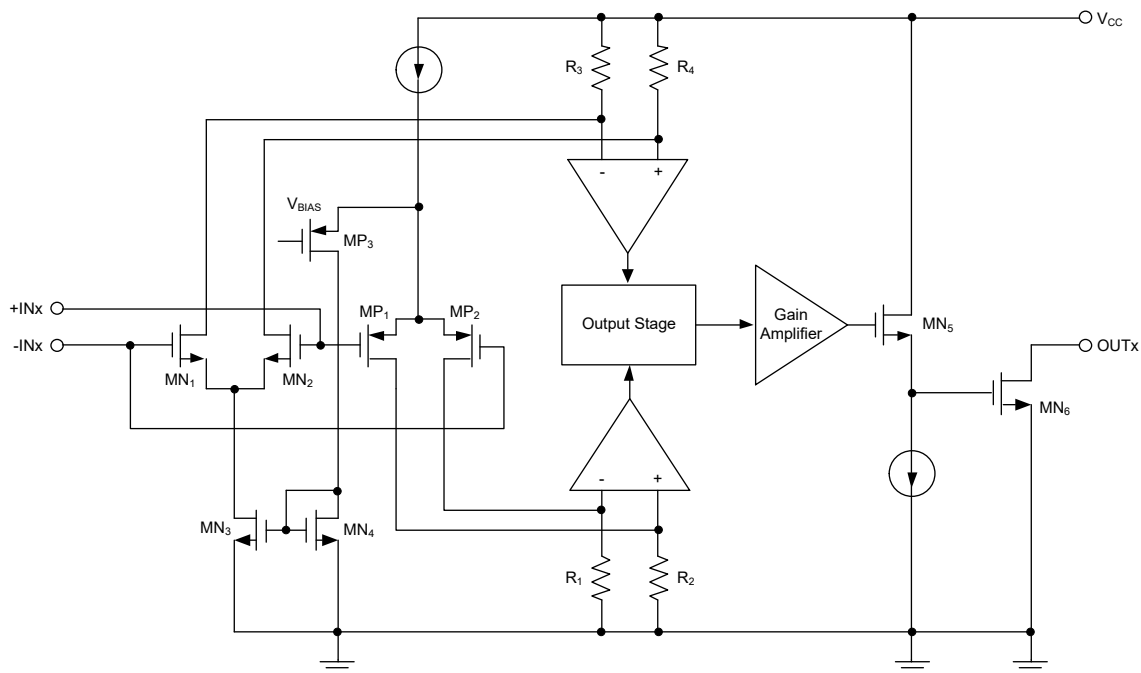

**Figure 2. Block Diagram**

**DETAILED DESCRIPTION**

The SGM8754-2 and SGM8754-4 can operate up to 5.5V power supply. Due to the low supply current and fast response, they are widely used in many applications such as industrial or portable applications.

The open-drain output provides the flexibility to configure the output logic, such as wire-AND function which can be realized by connecting the comparator output together.

The SGM8754-2 and SGM8754-4 operate as voltage comparators, which are able to compare the differential voltage between positive and negative input pins. They output a logic low or high (logic high with pull-up) to express the relationship between the two input voltages.

**APPLICATION INFORMATION**

For comparator applications, comparing between a single signal and a reference or comparing two signals are always encountered. The circuits in Figure 3 can be used to realize these designs. Due to open-drain output structure, it's easy to design the level shifting circuit between comparator's output and I/O of micro-controller, adjusting  $R_{PULL-UP}$  and  $V_{LOGIC}$ .  $V_{OH}$  and  $V_{OL}$  of the level shifting circuit and its transient response time will be adjusted.

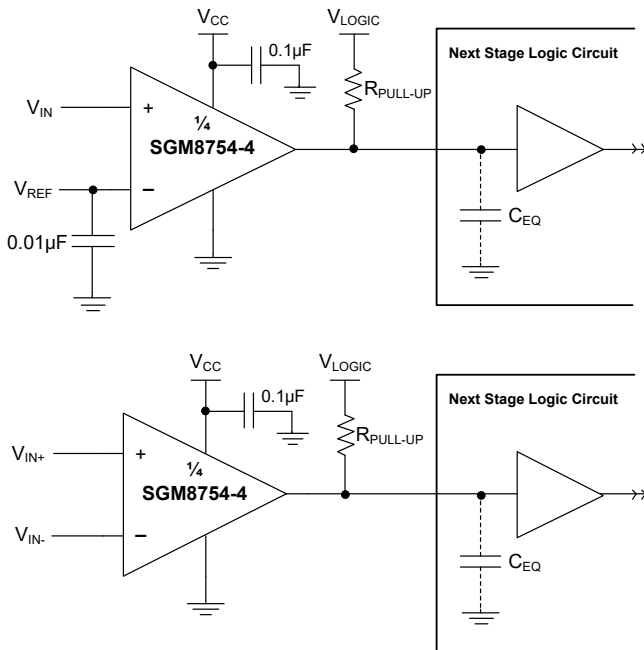

**Figure 3. Typical Application Circuits**

**Input Voltage Range**

In Figure 2, using a pair of P-MOSFETs and a pair of N-MOSFETs in a parallel structure at the input stage, the SGM8754-2/4 can support rail-to-rail input, and the input common mode voltage ( $V_{CM}$ ) is range from (GND - 0.1V) to ( $V_{CC} + 0.1V$ ). In applications,  $V_{CM}$  must be considered. If the operating voltage is outside the range of  $V_{CM}$ , the SGM8754-2/4 may generate incorrect comparison, so operating voltage must be inside the range of  $V_{CM}$  in applications.

**Output and Drive Current**

In Figure 3, the output and drive current are determined by the pull-up resistance ( $R_{PULL-UP}$ ),  $V_{LOGIC}$  and  $V_{OUT}$ . Refer to the Equation 1:

$$I_{OUT} = (V_{LOGIC} - V_{OUT})/R_{PULL-UP} \quad (1)$$

The current through  $R_{PULL-UP}$  will generate the logic low output voltage ( $V_{OL}$ ). The output and drive current of comparator will be adjusted by adjusting  $R_{PULL-UP}$ , at the same time, the transient response time can be adjusted.

**Transient Response Time**

The transient response time can be determined by the equivalent capacitance ( $C_{EQ}$ ),  $R_{PULL-UP}$  and  $MN_6$  low-side MOSFET's  $R_{DSON}$  in Figure 2. The order of magnitude of positive response time ( $t_p$ ) is about  $R_{PULL-UP} \times C_{EQ}$ , and the order of magnitude of negative response time ( $t_n$ ) is about  $R_{DSON} \times C_{EQ}$ .

**Power Supply Bypassing**

A clean and stable power supply is very important in comparator circuit design to minimize noise, glitch and temporary fluctuation. The power supply is one of the important sources of noise to the comparator through  $V_{CC}$  pin. Power supply bypassing is an effective method to clear up the noise at power supply. The low impedance path to ground of decoupling capacitor will bypass the noise to GND. In applications, 0.1µF ceramic capacitor is always used, and this ceramic capacitor should be placed as close as possible to  $V_{CC}$  pin.

## **REVISION HISTORY**

NOTE: Page numbers for previous revisions may differ from page numbers in the current version.

<b>APRIL 2026 – REV.A to REV.A.1</b>	<b>Page</b>
Added SGM8754-4XTS14G .....	All
Updated Absolute Maximum Ratings section.....	3

---

<b>Changes from Original to REV.A (APRIL 2024)</b>	<b>Page</b>
Changed from product preview to production data.....	All

---

PACKAGE OUTLINE DIMENSIONS

UTQFN-2x2-14BL

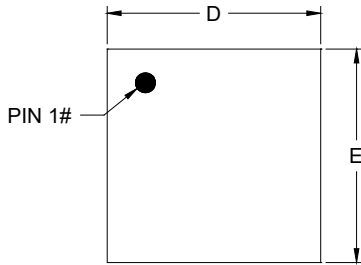

TOP VIEW

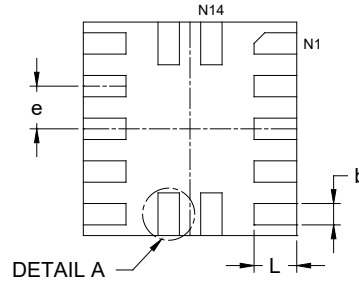

BOTTOM VIEW

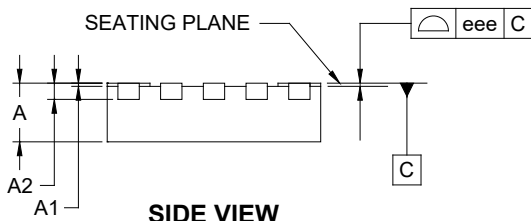

SIDE VIEW

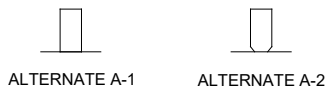

DETAIL A

ALTERNATE TERMINAL CONSTRUCTION

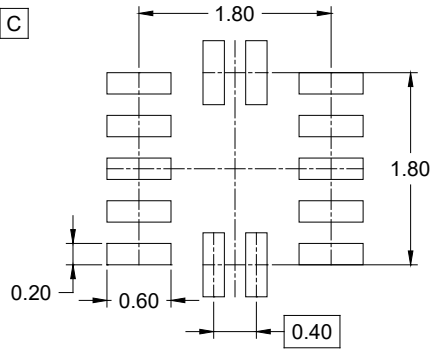

RECOMMENDED LAND PATTERN (Unit: mm)

Symbol	Dimensions In Millimeters		
	MIN	NOM	MAX
A	0.500	-	0.600
A1	0.000	-	0.050
A2	0.152 REF		
b	0.150	-	0.250
D	1.900	-	2.100
E	1.900	-	2.100
e	0.400 BSC		
L	0.300	-	0.500
eee	0.050		

NOTE: This drawing is subject to change without notice.

PACKAGE OUTLINE DIMENSIONS

SOIC-8

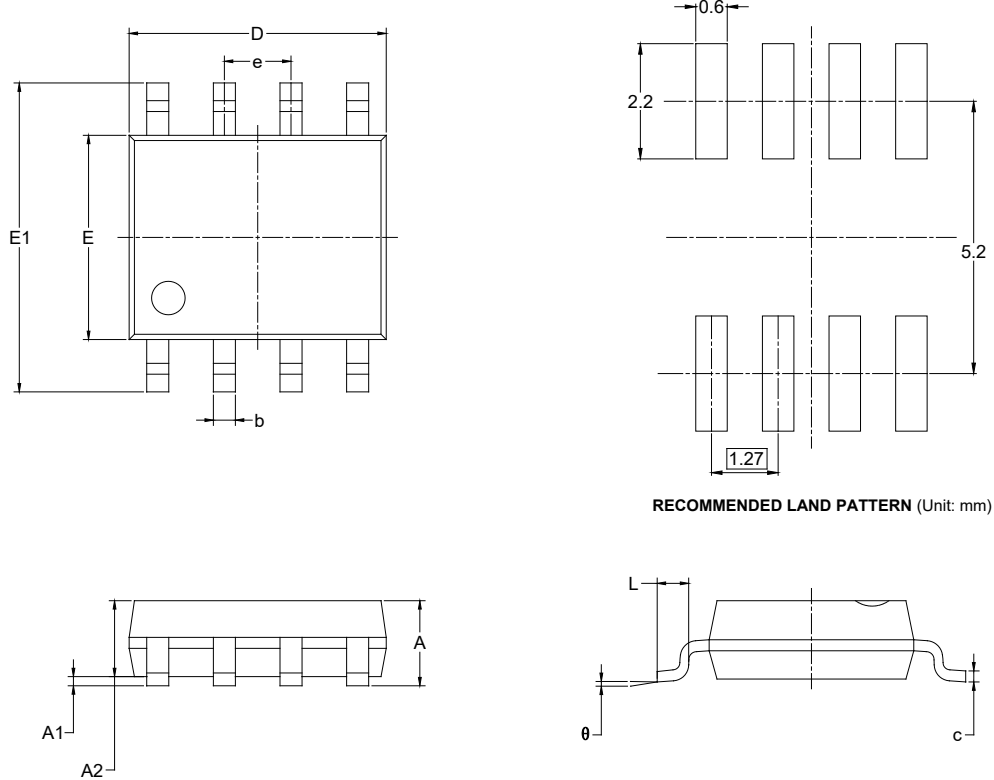

RECOMMENDED LAND PATTERN (Unit: mm)

Symbol	Dimensions In Millimeters		Dimensions In Inches	
	MIN	MAX	MIN	MAX
A	1.350	1.750	0.053	0.069
A1	0.100	0.250	0.004	0.010
A2	1.350	1.550	0.053	0.061
b	0.330	0.510	0.013	0.020
c	0.170	0.250	0.006	0.010
D	4.700	5.100	0.185	0.200
E	3.800	4.000	0.150	0.157
E1	5.800	6.200	0.228	0.244
e	1.27 BSC		0.050 BSC	
L	0.400	1.270	0.016	0.050
$\theta$	0°	8°	0°	8°

NOTES:

1. Body dimensions do not include mold flash or protrusion.
2. This drawing is subject to change without notice.

PACKAGE OUTLINE DIMENSIONS

MSOP-8

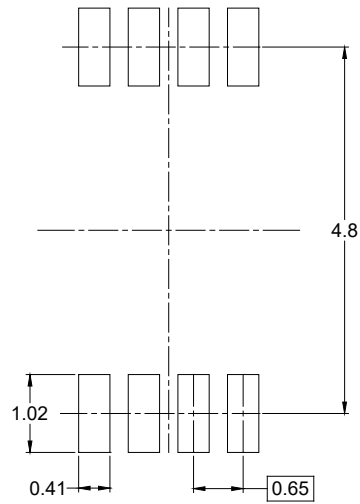
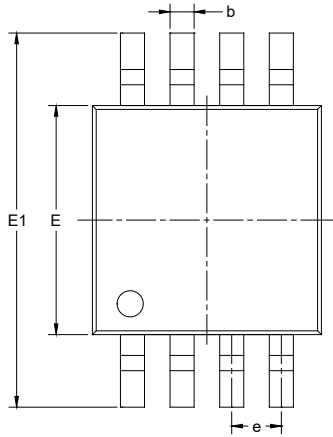

RECOMMENDED LAND PATTERN (Unit: mm)

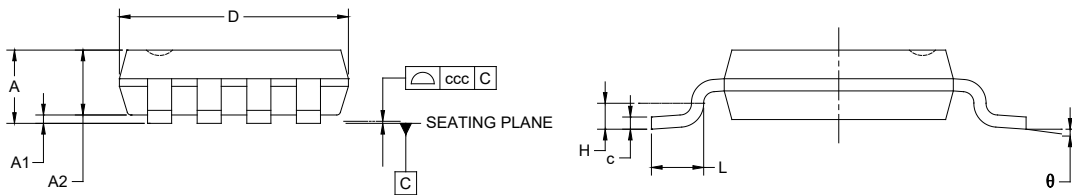

Symbol	Dimensions In Millimeters		
	MIN	NOM	MAX
A	-	-	1.100
A1	0.000	-	0.150
A2	0.750	-	0.950
b	0.220	-	0.380
c	0.080	-	0.230
D	2.800	-	3.200
E	2.800	-	3.200
E1	4.650	-	5.150
e	0.650 BSC		
L	0.400	-	0.800
H	0.250 TYP		
theta	0°	-	8°
ccc	0.100		

NOTES:

1. This drawing is subject to change without notice.
2. The dimensions do not include mold flashes, protrusions or gate burrs.
3. Reference JEDEC MO-187.

# PACKAGE INFORMATION

## PACKAGE OUTLINE DIMENSIONS

### SOIC-14

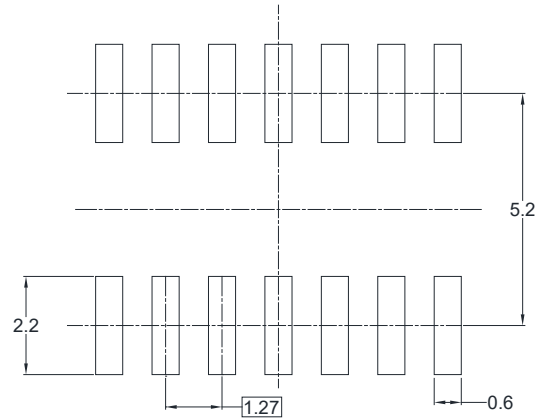
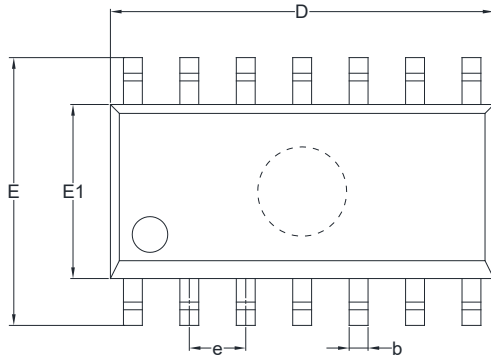

RECOMMENDED LAND PATTERN (Unit: mm)

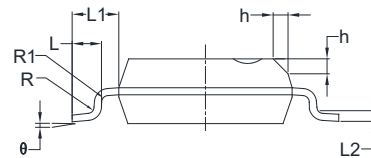
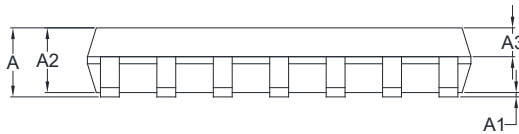

Symbol	Dimensions In Millimeters		Dimensions In Inches	
	MIN	MAX	MIN	MAX
A	1.35	1.75	0.053	0.069
A1	0.10	0.25	0.004	0.010
A2	1.25	1.65	0.049	0.065
A3	0.55	0.75	0.022	0.030
b	0.36	0.49	0.014	0.019
D	8.53	8.73	0.336	0.344
E	5.80	6.20	0.228	0.244
E1	3.80	4.00	0.150	0.157
e	1.27 BSC		0.050 BSC	
L	0.45	0.80	0.018	0.032
L1	1.04 REF		0.040 REF	
L2	0.25 BSC		0.01 BSC	
R	0.07		0.003	
R1	0.07		0.003	
h	0.30	0.50	0.012	0.020
θ	0°	8°	0°	8°

NOTES:

1. Body dimensions do not include mold flash or protrusion.
2. This drawing is subject to change without notice.

PACKAGE OUTLINE DIMENSIONS

TSSOP-14

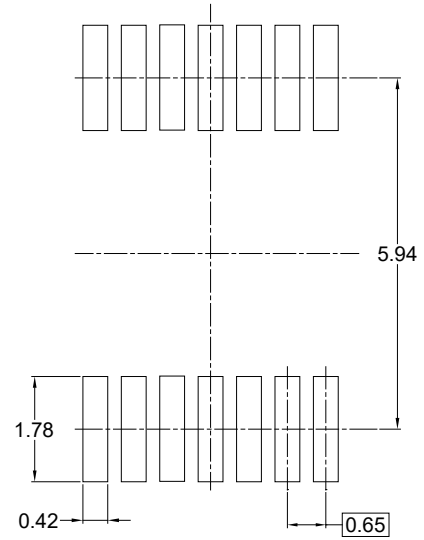
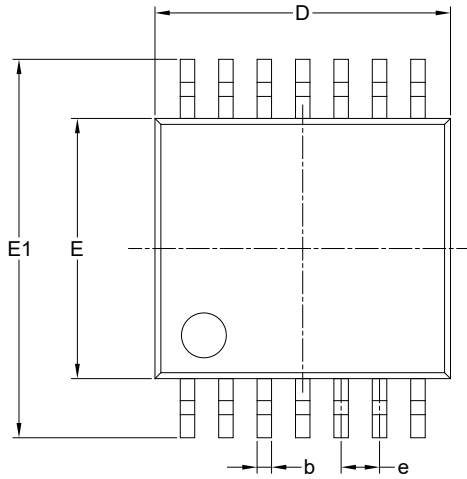

RECOMMENDED LAND PATTERN (Unit: mm)

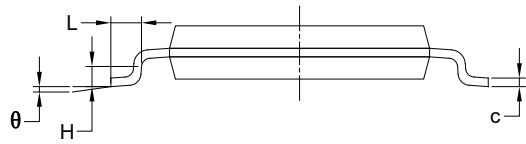
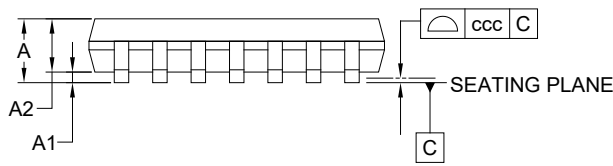

Symbol	Dimensions In Millimeters		
	MIN	NOM	MAX
A	-	-	1.200
A1	0.050	-	0.150
A2	0.800	-	1.050
b	0.190	-	0.300
c	0.090	-	0.200
D	4.860	-	5.100
E	4.300	-	4.500
E1	6.200	-	6.600
e	0.650 BSC		
L	0.450	-	0.750
H	0.250 TYP		
$\theta$	0°	-	8°
ccc	0.100		

NOTES:

1. This drawing is subject to change without notice.
2. The dimensions do not include mold flashes, protrusions or gate burrs.
3. Reference JEDEC MO-153.

# PACKAGE INFORMATION

## TAPE AND REEL INFORMATION

### REEL DIMENSIONS

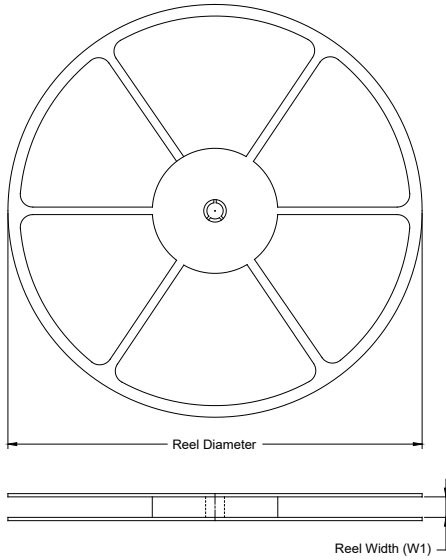

### TAPE DIMENSIONS

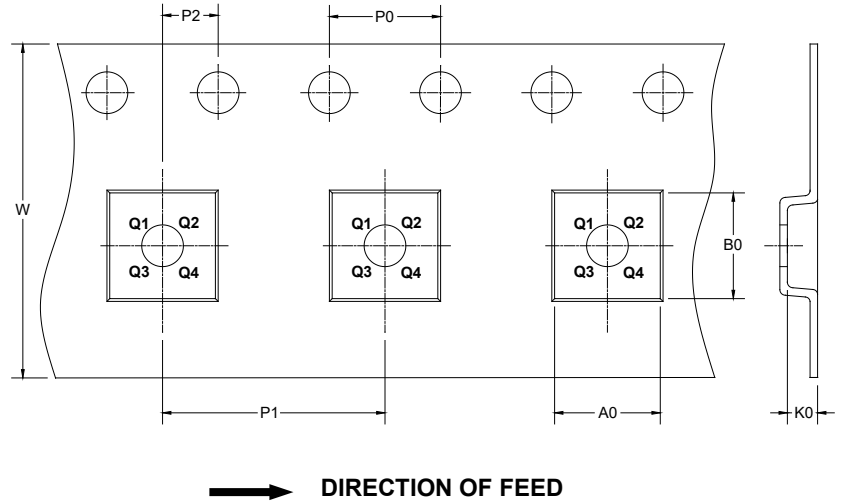

NOTE: The picture is only for reference. Please make the object as the standard.

### KEY PARAMETER LIST OF TAPE AND REEL

Package Type	Reel Diameter	Reel Width W1 (mm)	A0 (mm)	B0 (mm)	K0 (mm)	P0 (mm)	P1 (mm)	P2 (mm)	W (mm)	Pin1 Quadrant
UTQFN-2×2-14BL	7"	9.5	2.25	2.25	0.75	4.0	4.0	2.0	8.0	Q2
SOIC-8	13"	12.4	6.40	5.40	2.10	4.0	8.0	2.0	12.0	Q1
MSOP-8	13"	12.4	5.20	3.30	1.50	4.0	8.0	2.0	12.0	Q1
SOIC-14	13"	16.4	6.60	9.30	2.10	4.0	8.0	2.0	16.0	Q1
TSSOP-14	13"	12.4	6.80	5.40	1.50	4.0	8.0	2.0	12.0	Q1

DD0001

# PACKAGE INFORMATION

## CARTON BOX DIMENSIONS

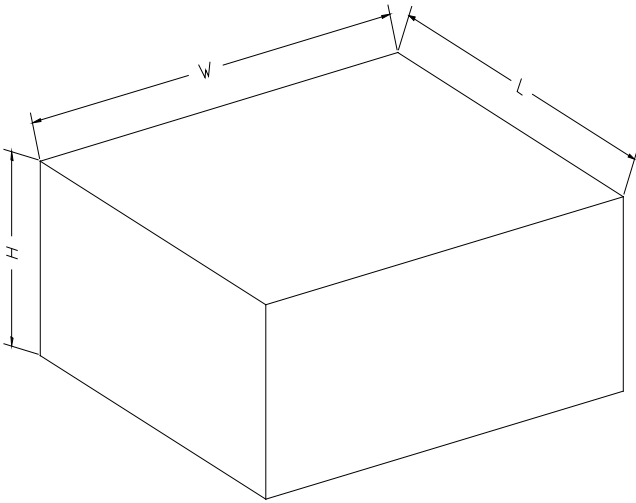

NOTE: The picture is only for reference. Please make the object as the standard.

## KEY PARAMETER LIST OF CARTON BOX

Reel Type	Length (mm)	Width (mm)	Height (mm)	Pizza/Carton
7" (Option)	368	227	224	8
7"	442	410	224	18
13"	386	280	370	5

DD0002