

### FEATURES

- GaN-on-Silicon E-Mode HEMT Technology
- Very Low Gate Charge
- Ultra-Low On-Resistance
- Very Small Footprint
- RoHS Compliant and Halogen Free

### APPLICATIONS

High Frequency DC/DC Converter  
 Point of Load  
 RF Envelope Tracking  
 PC Charger  
 Mobile Power Bank  
 Motor Driver

### PRODUCT SUMMARY

$R_{DS(on)}$ (TYP) $V_{GS} = 5V$	$R_{DS(on)}$ (MAX) $V_{GS} = 5V$	$I_D$ (MAX) $T_C = +25^\circ C$
3m $\Omega$	4.3m $\Omega$	24A

### PIN CONFIGURATION

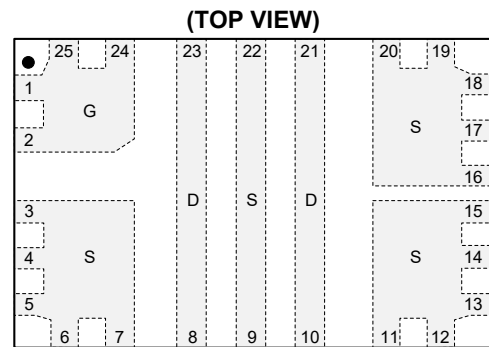

TQFN-4x3-25L

### ABSOLUTE MAXIMUM RATINGS

PARAMETER	SYMBOL	VALUE	UNITS
Drain-to-Source Voltage	$V_{DS}$	40	V
Gate-to-Source Voltage	$V_{GS}$	6	V
		-4	
Drain Current	$I_D$	24	A
Drain Current (Pulse) <sup>(1)</sup>	$I_{DM}$	160	A
Total Dissipation	$P_D$	43	W
Junction Temperature	$T_J$	-40 to +150	$^\circ C$
Storage Temperature Range	$T_{STG}$	-40 to +150	$^\circ C$
Lead Temperature (Soldering, 10s)		+260	$^\circ C$

Stresses beyond those listed in Absolute Maximum Ratings may cause permanent damage to the device. Exposure to absolute maximum rating conditions for extended periods may affect reliability.

NOTE: 1.  $t_{PULSE} = 300\mu s$ .

### EQUIVALENT CIRCUIT

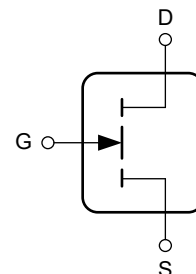

**PACKAGE/ORDERING INFORMATION**

MODEL	PACKAGE DESCRIPTION	SPECIFIED TEMPERATURE RANGE	ORDERING NUMBER	PACKAGE MARKING	PACKING OPTION
SGMGQ03340	TQFN-4x3-25L	-40°C to +150°C	SGMGQ03340TTXC25G/TR	SGM 2TLTXC XXXXX	Tape and Reel, 2500

**MARKING INFORMATION**

NOTE: XXXXX = Date Code, Trace Code and Vendor Code.

**XXXXX**

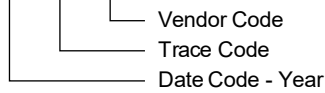

Green (RoHS & HSF): SG Micro Corp defines "Green" to mean Pb-Free (RoHS compatible) and free of halogen substances. If you have additional comments or questions, please contact your SGMICRO representative directly.

**DISCLAIMER**

SG Micro Corp reserves the right to make any change in circuit design, or specifications without prior notice.

**THERMAL RESISTANCE**

PARAMETER	SYMBOL	TYP	UNITS
Junction-to-Ambient Thermal Resistance <sup>(1)</sup>	R <sub>θJA</sub>	45.9	°C/W
Junction-to-Case Thermal Resistance	R <sub>θJC_TOP</sub>	26.2	°C/W
	R <sub>θJC_BOTTOM</sub>	2.9	

NOTE: 1. R<sub>θJA</sub> is determined with the device mounted on one square inch of copper pad, single layer 2oz copper on FR4 board.

**ELECTRICAL CHARACTERISTICS**(T<sub>J</sub> = +25°C, unless otherwise noted.)

PARAMETER	SYMBOL	CONDITIONS	MIN	TYP	MAX	UNITS
<b>Static Characteristics</b>						
Drain-to-Source Breakdown Voltage	V <sub>BR_DSS</sub>	V <sub>GS</sub> = 0V, I <sub>D</sub> = 500μA	40			V
Zero Gate Voltage Drain Current	I <sub>DSS</sub>	V <sub>GS</sub> = 0V, V <sub>DS</sub> = 32V			100	μA
Gate-to-Source Leakage Current	I <sub>GSS</sub>	V <sub>GS</sub> = 5V		3	80	μA
		V <sub>GS</sub> = 5V, T <sub>J</sub> = +125°C		50	500	
		V <sub>GS</sub> = -4V		1	20	
Gate-to-Source Threshold Voltage	V <sub>GS_TH</sub>	V <sub>GS</sub> = V <sub>DS</sub> , I <sub>D</sub> = 7mA	0.7		2.4	V
Drain-to-Source On-State Resistance	R <sub>DS(on)</sub>	V <sub>GS</sub> = 5V, I <sub>D</sub> = 15A		3	4.3	mΩ
Gate Resistance	R <sub>G</sub>	f = 1MHz		1.7		Ω
Source-to-Drain Forward Voltage	V <sub>SD</sub>	V <sub>GS</sub> = 0V, I <sub>S</sub> = 0.5A		1.9		V
<b>Dynamic Characteristics</b>						
Input Capacitance	C <sub>ISS</sub>	V <sub>GS</sub> = 0V, V <sub>DS</sub> = 20V		810		pF
Output Capacitance	C <sub>OSS</sub>			431		
Reverse Transfer Capacitance	C <sub>RSS</sub>			13		
Effective Output Capacitance, Energy Related	C <sub>O_ER</sub>	V <sub>GS</sub> = 5V, V <sub>DS</sub> = 20V, I <sub>D</sub> = 15A		600		pF
Effective Output Capacitance, Time Related	C <sub>O_TR</sub>			703		
Total Gate Charge	Q <sub>G</sub>	V <sub>GS</sub> = 5V, V <sub>DS</sub> = 20V, I <sub>D</sub> = 15A		6.3	8.5	nC
Gate-to-Source Charge	Q <sub>GS</sub>	V <sub>DS</sub> = 20V, I <sub>D</sub> = 15A		1.4		
Gate-to-Drain Charge	Q <sub>GD</sub>			0.8		
Gate Charge at Threshold	Q <sub>G_TH</sub>			0.9		
Output Charge	Q <sub>OSS</sub>		V <sub>GS</sub> = 0V, V <sub>DS</sub> = 0V to 20V		14	

TYPICAL PERFORMANCE CHARACTERISTICS

Figure 1 Typical Output Characteristics ( $T_J = 25\text{ }^\circ\text{C}$ )

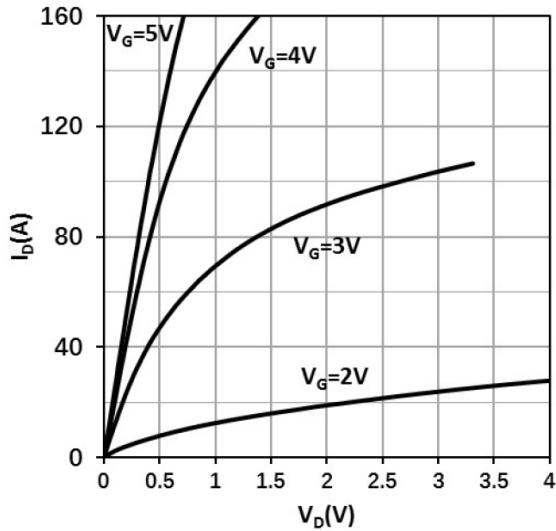

Figure 2 Typical Output Characteristics ( $T_J = 125\text{ }^\circ\text{C}$ )

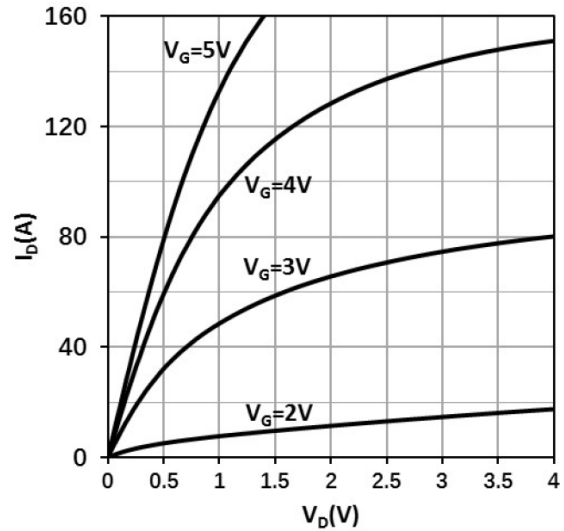

Figure 3 Typ. Drain On-state Resistance ( $T_J = 25\text{ }^\circ\text{C}$ )

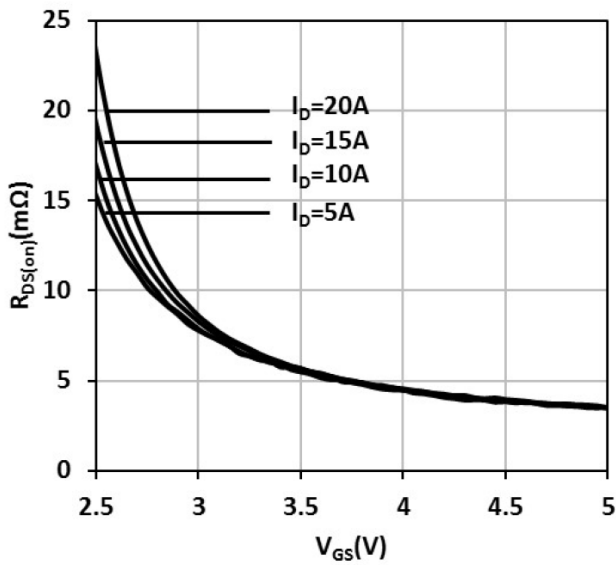
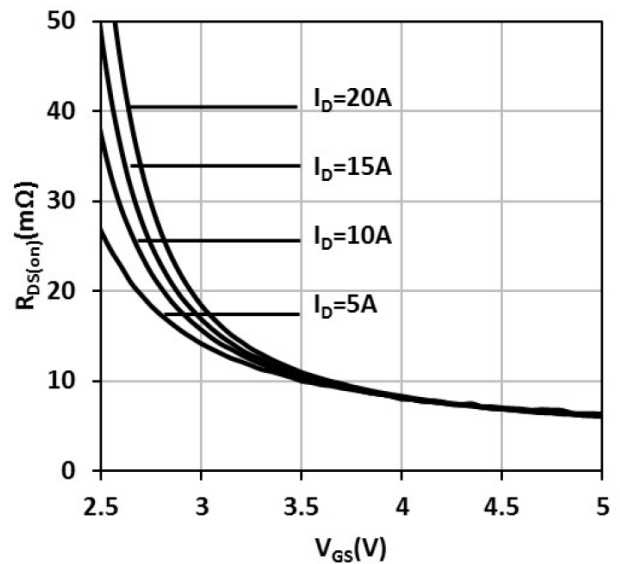

Figure 4 Typ. Drain On-state Resistance ( $T_J = 125\text{ }^\circ\text{C}$ )



TYPICAL PERFORMANCE CHARACTERISTICS (continued)

Figure 5 Typical On Resistance vs. Temperature

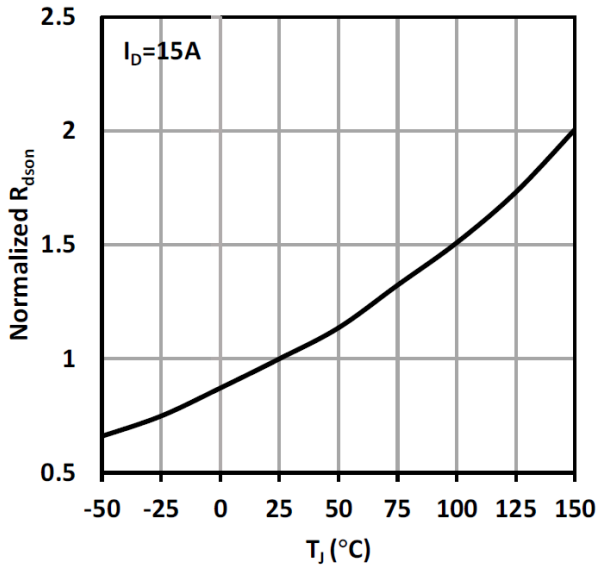

Figure 6 Typical Transfer Characteristics

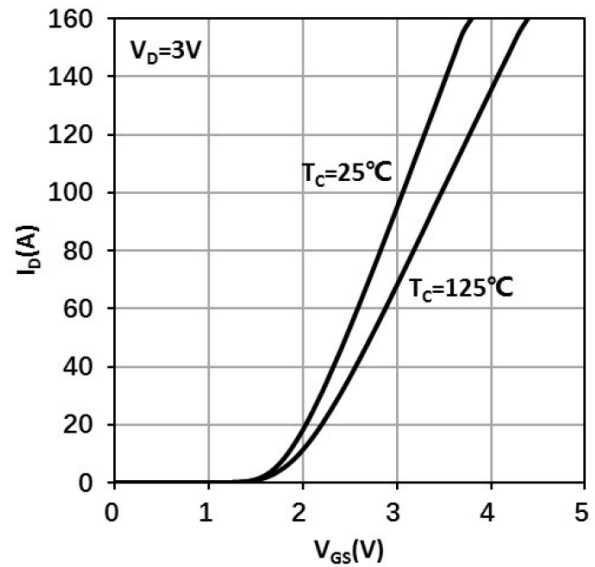

Figure 7 Typ. Reverse Drain-Source Characteristics ( $V_{GS} \leq 0, T_J = 25^{\circ}C$ )

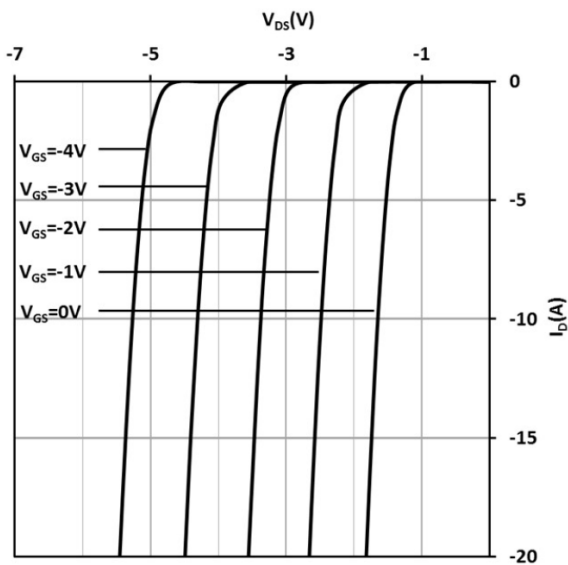
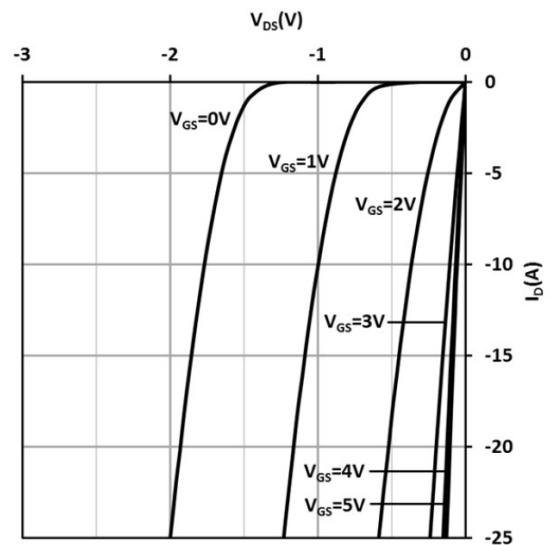

Figure 8 Typ. Reverse Drain-Source Characteristics ( $V_{GS} \geq 0, T_J = 25^{\circ}C$ )



TYPICAL PERFORMANCE CHARACTERISTICS (continued)

Figure 9 Typ. Reverse Drain-Source Characteristics ( $V_{GS} \leq 0, T_J = 125^\circ\text{C}$ )

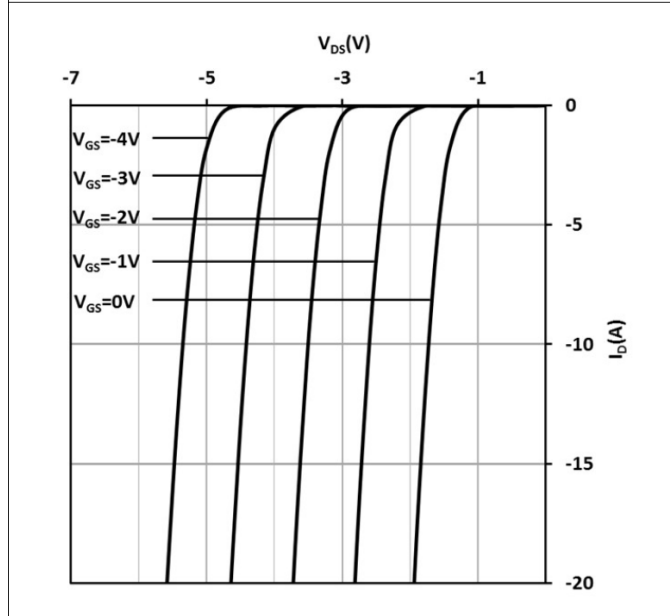

Figure 10 Typ. Reverse Drain-Source Characteristics ( $V_{GS} \geq 0, T_J = 125^\circ\text{C}$ )

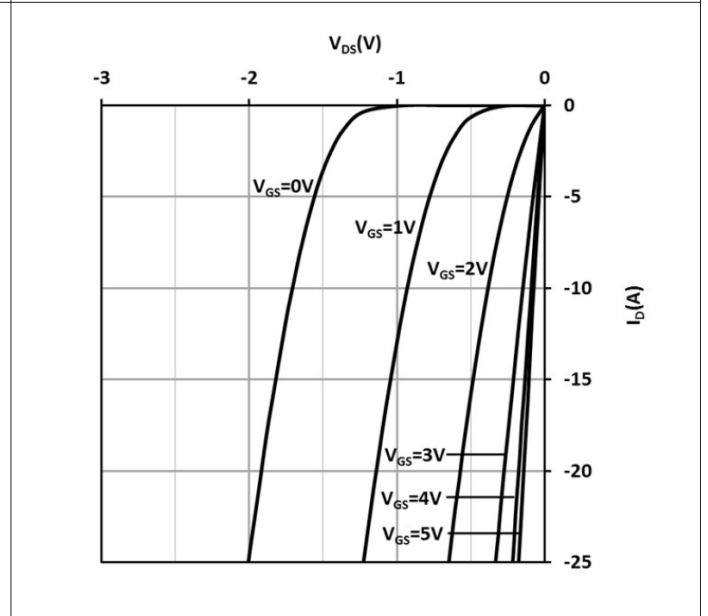

Figure 11 Typ. Capacitances Characteristics

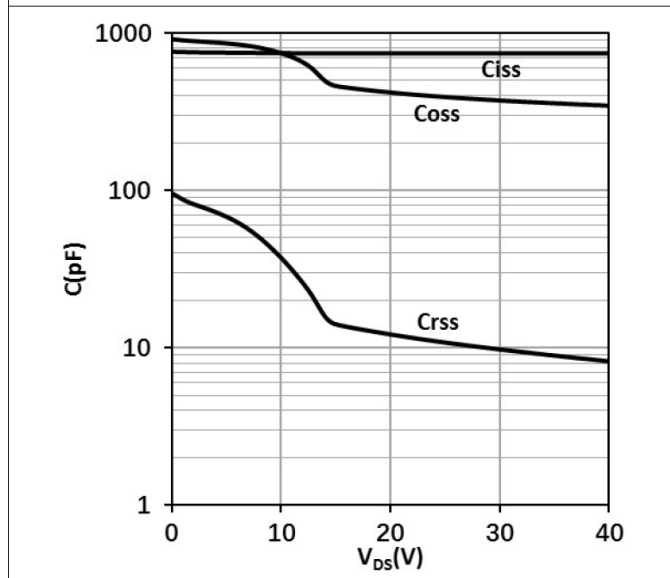
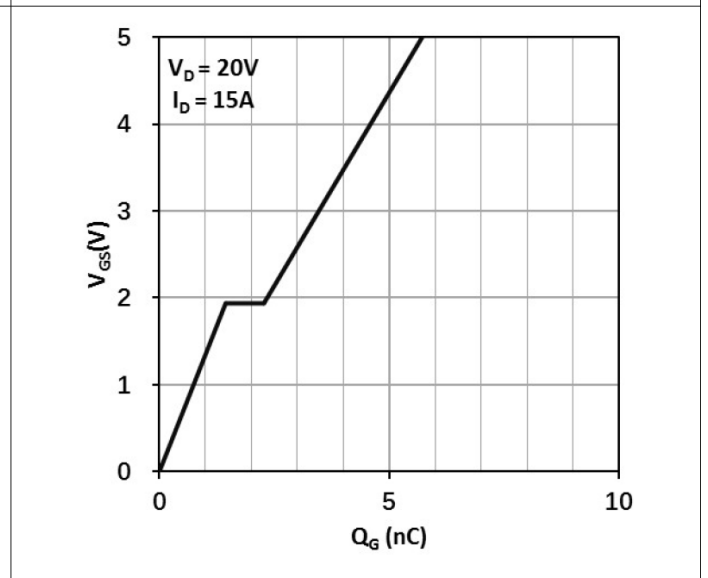

Figure 12 Typ. Gate Charge



TYPICAL PERFORMANCE CHARACTERISTICS (continued)

Figure 13 Normalized Threshold Voltage vs. Temp.

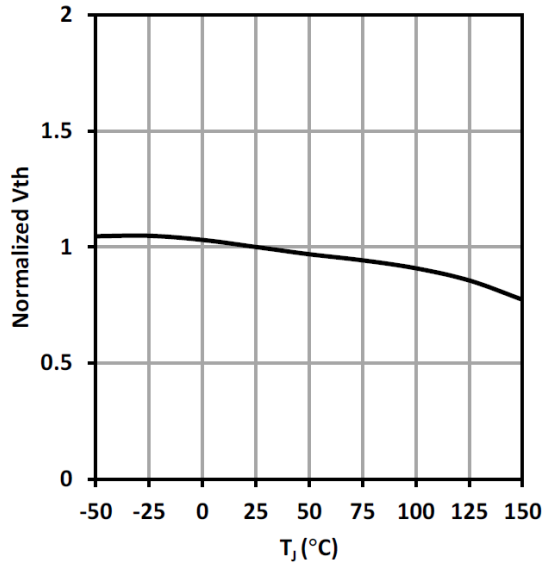

Figure 14 Output Charge

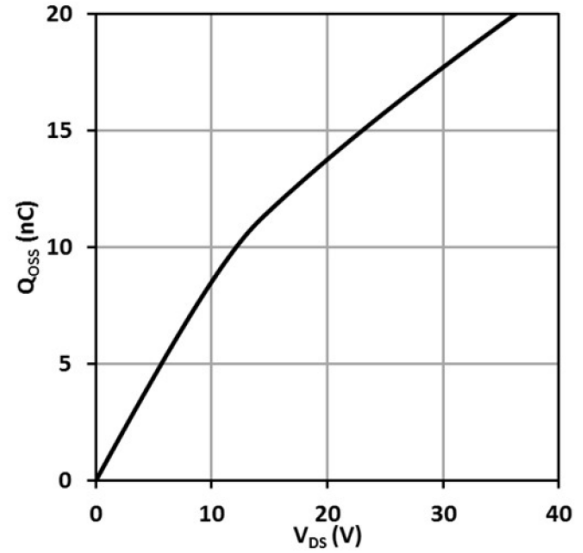

Figure 15 Output Capacitance Stored Energy

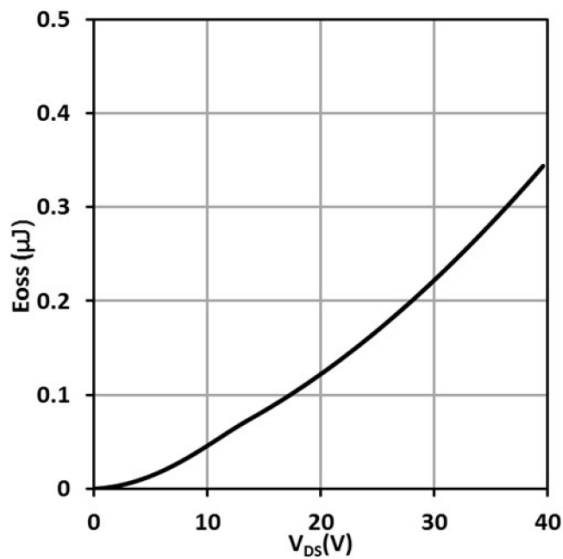
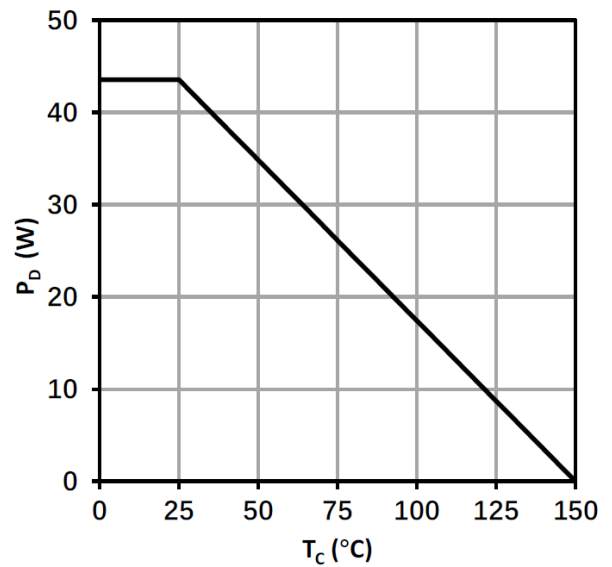

Figure 16 Power Dissipation



TYPICAL PERFORMANCE CHARACTERISTICS (continued)

Figure 17 Safe Operating Area

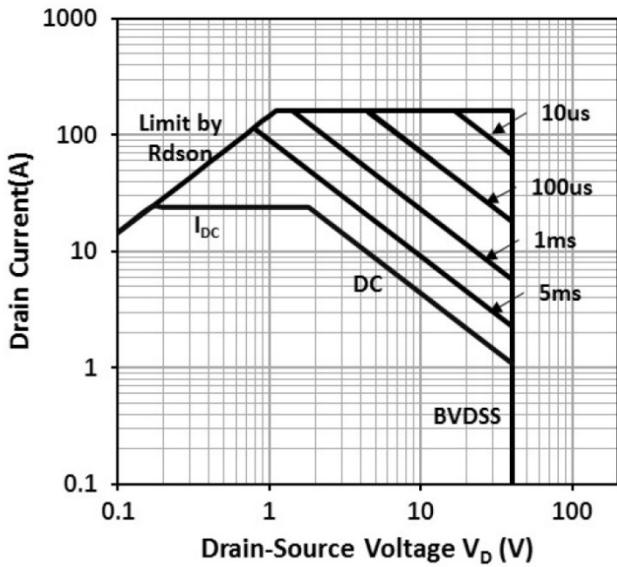
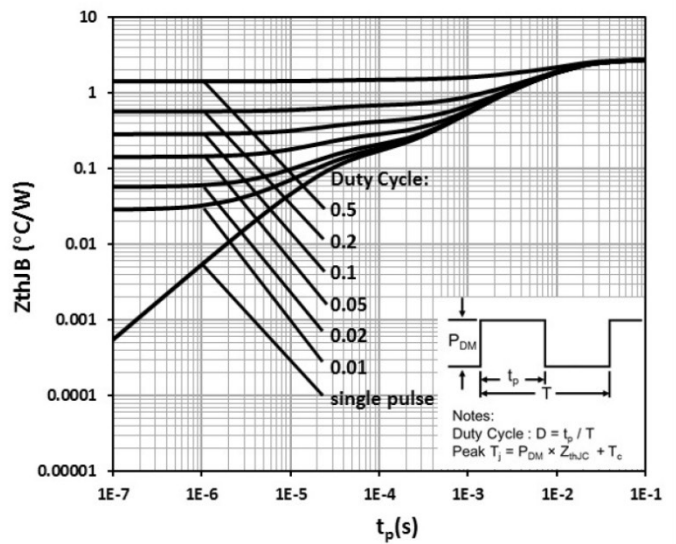

Figure 18 Max. Transient Thermal Impedance



REVISION HISTORY

NOTE: Page numbers for previous revisions may differ from page numbers in the current version.

Changes from Original to REV.A (JUNE 2026)	Page
Changed from product preview to production data.....	All

PACKAGE OUTLINE DIMENSIONS

TQFN-4x3-25L

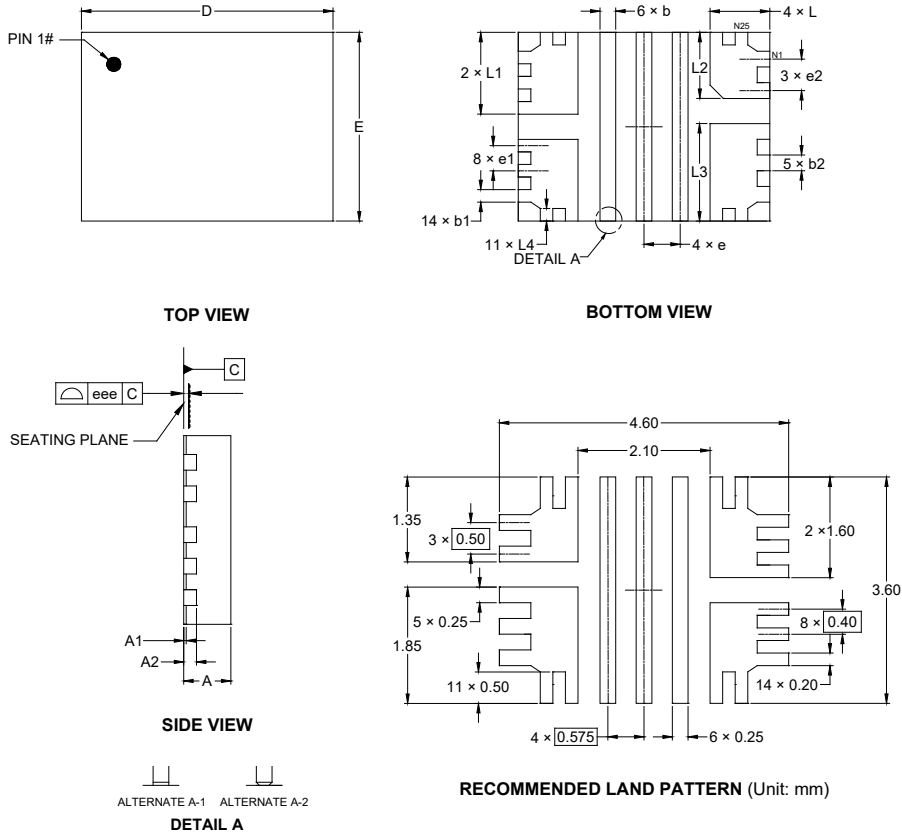

Symbol	Dimensions In Millimeters		
	MIN	NOM	MAX
A	0.700	-	0.800
A1	0.000	-	0.050
A2	0.203 REF		
b	0.200	-	0.300
b1	0.200 REF		
b2	0.250 REF		
D	3.900	-	4.100
E	2.900	-	3.100
e	0.575 BSC		
e1	0.400 REF		
e2	0.500 REF		
L	0.850	-	1.050
L1	1.200	-	1.400
L2	0.950	-	1.150
L3	1.450	-	1.650
L4	0.200 REF		
eee	0.080		

NOTE: This drawing is subject to change without notice.

TAPE AND REEL INFORMATION

REEL DIMENSIONS

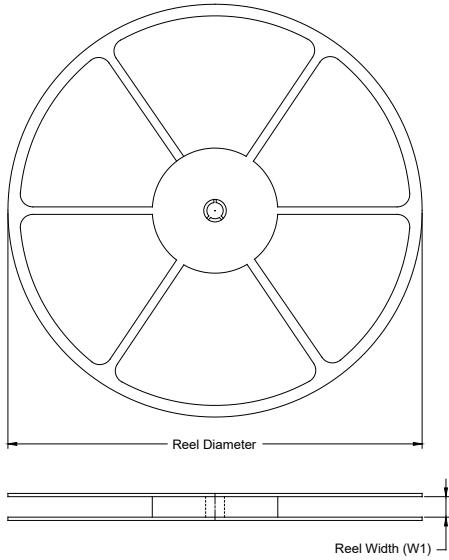

TAPE DIMENSIONS

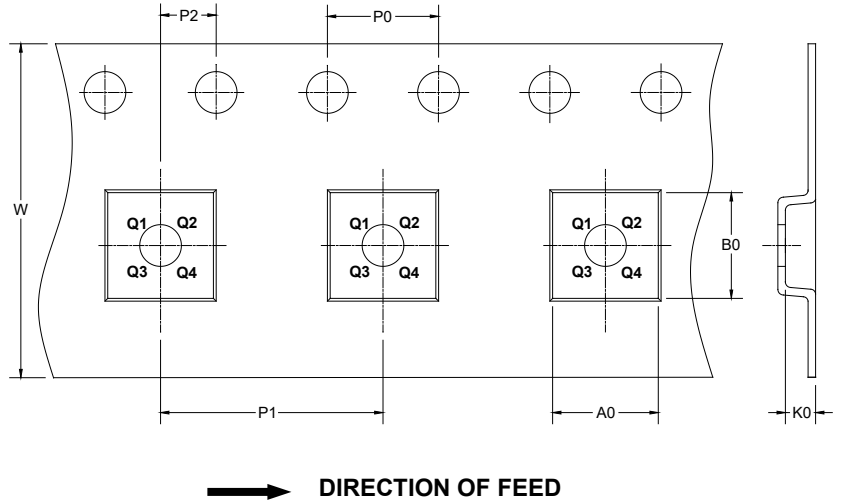

NOTE: The picture is only for reference. Please make the object as the standard.

KEY PARAMETER LIST OF TAPE AND REEL

Package Type	Reel Diameter	Reel Width W1 (mm)	A0 (mm)	B0 (mm)	K0 (mm)	P0 (mm)	P1 (mm)	P2 (mm)	W (mm)	Pin1 Quadrant
TQFN-4×3-25L	13"	12.4	3.30	4.30	1.10	4.0	8.0	2.0	12.0	Q2

DD0001

# PACKAGE INFORMATION

## CARTON BOX DIMENSIONS

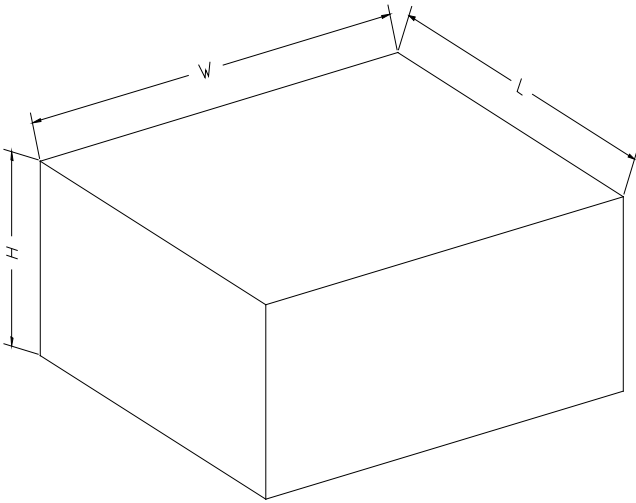

NOTE: The picture is only for reference. Please make the object as the standard.

## KEY PARAMETER LIST OF CARTON BOX

Reel Type	Length (mm)	Width (mm)	Height (mm)	Pizza/Carton
13"	386	280	370	5

DD0002