



SGM3712YTQA

0.9Ω, High Voltage, Rail-to-Rail Negative Signal Passing, Dual, SPDT Analog Switch

GENERAL DESCRIPTION

The SGM3712YTQA is a dual SPDT (single-pole/double-throw) analog switch. It operates from a 2.7V to 12V single power supply and allows negative signal passing with low distortion.

The SGM3712YTQA features low on-resistance, high voltage and fast switching times. The high performances make it very suitable for multiple applications. In addition, the SGM3712YTQA can be used as a dual 2-to-1 multiplexer because it has two normally open and close switches, respectively.

The SGM3712YTQA is available in a Green TQFN-2.6×1.8-16L package. It operates over an ambient temperature range of -40°C to +85°C.

FEATURES

- **Single Supply Voltage Range: 2.7V to 12V**
- **Low On-Resistance: 0.9Ω (TYP)**
- **-V_{CC} to +V_{CC} Positive and Negative Signal Passing**
- **Low Distortion**
- **Fast Switching Times**
- **High Off-Isolation**
- **Low Crosstalk: -90dB at 1MHz**
- **1.8V Logic Control**
- **Break-Before-Make Switching**
- **-40°C to +85°C Operating Temperature Range**
- **Available in a Green TQFN-2.6×1.8-16L Package**

APPLICATIONS

Portable Equipment
Battery-Powered Systems

SGM3712YTQA 0.9Ω, High Voltage, Rail-to-Rail Negative Signal Passing, Dual, SPDT Analog Switch

PACKAGE/ORDERING INFORMATION

MODEL	PACKAGE DESCRIPTION	SPECIFIED TEMPERATURE RANGE	ORDERING NUMBER	PACKAGE MARKING	PACKING OPTION
SGM3712YTQA	TQFN-2.6×1.8-16L	-40°C to +85°C	SGM3712YTQA16G/TR	3712 XXXXX	Tape and Reel, 3000

MARKING INFORMATION

NOTE: XXXXX = Date Code, Trace Cod and Vendor Code.

TQFN-2.6×1.8-16L

XXXXX

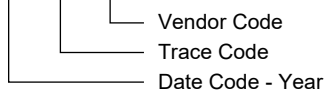

Green (RoHS & HSF): SG Micro Corp defines "Green" to mean Pb-Free (RoHS compatible) and free of halogen substances. If you have additional comments or questions, please contact your SGMICRO representative directly.

ABSOLUTE MAXIMUM RATINGS

V _{CC} to GND	0V to 13.2V
IN1, IN2, EN to GND	0V to 6V
Analog Voltage Range ⁽¹⁾	(-V _{CC} - 0.3V) to (V _{CC} + 0.3V)
Continuous Current from NO to COM	±350mA
Continuous Current from NC to COM	±350mA
Peak Current from NO to COM	±400mA
Peak Current from NC to COM	±400mA
I/O Clamp Current (V _I < 0)	-30mA
Package Thermal Resistance	
TQFN-2.6×1.8-16L, θ _{JA}	64°C/W
TQFN-2.6×1.8-16L, θ _{JB}	8°C/W
TQFN-2.6×1.8-16L, θ _{JC}	55°C/W
Junction Temperature	+150°C
Storage Temperature Range	-65°C to +150°C
Lead Temperature (Soldering, 10s)	+260°C
ESD Susceptibility	
HBM	±8000V
CDM	±1000V

NOTE:

1. Internal diodes will clamp voltages at NC, NO, or COM that exceed V_{CC}. Limit the current through the forward diode to the maximum ratings.

RECOMMENDED OPERATING CONDITIONS

Supply Voltage Range	2.7V to 12V
Operating Temperature Range	-40°C to +85°C

OVERSTRESS CAUTION

Stresses beyond those listed in Absolute Maximum Ratings may cause permanent damage to the device. Exposure to absolute maximum rating conditions for extended periods may affect reliability. Functional operation of the device at any conditions beyond those indicated in the Recommended Operating Conditions section is not implied.

ESD SENSITIVITY CAUTION

This integrated circuit can be damaged if ESD protections are not considered carefully. SGMICRO recommends that all integrated circuits be handled with appropriate precautions. Failure to observe proper handling and installation procedures can cause damage. ESD damage can range from subtle performance degradation to complete device failure. Precision integrated circuits may be more susceptible to damage because even small parametric changes could cause the device not to meet the published specifications.

DISCLAIMER

SG Micro Corp reserves the right to make any change in circuit design, or specifications without prior notice.

PIN CONFIGURATION

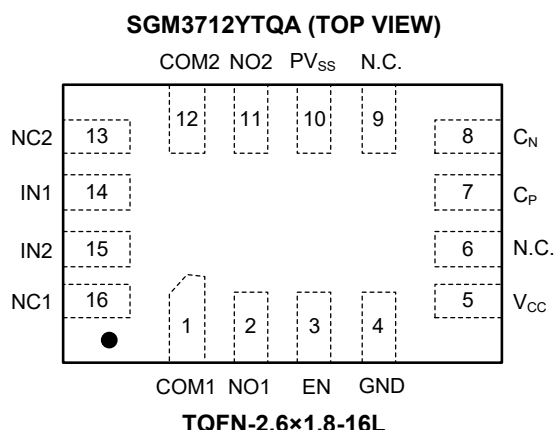

PIN DESCRIPTION

PIN	NAME	FUNCTION
1, 12	COM1, COM2	Common Pins.
2, 11	NO1, NO2	Normally Open Pins.
16, 13	NC1, NC2	Normally Closed Pins.
3	EN	Enable Control Pin. When EN = “Low”, both NC and NO are disconnected with COM, negative charge pump does not work and the SGM3712YTQA is in shutdown state. When EN = “High”, negative charge pump works, the SGM3712YTQA is in working state, and NC or NO is connected with COM depending on the logical state of IN.
4	GND	Ground.
5	V _{CC}	Power Supply Pin.
6, 9	N.C.	No Connection.
7	C _P	Charge Pump Flying Capacitor Positive Pin.
8	C _N	Charge Pump Flying Capacitor Negative Pin.
10	PV _{SS}	Negative Supply Voltage Output Pin. Connect one 0.1μF ceramic capacitor from PV _{SS} to GND.
14	IN1	Digital Control Pin. It is used to connect COM1 to NO1 or NC1.
15	IN2	Digital Control Pin. It is used to connect COM2 to NO2 or NC2.

NOTE: NO, NC and COM pins may be an input or output.

FUNCTION TABLE

Table 1. Function Table of Switch 1:

EN	IN1	COM1	NEGATIVE CHARGE PUMP
0	X	COM1 is disconnected with NO1 and NC1	Turn Off
1	0	COM1 = NC1	Turn On
1	1	COM1 = NO1	Turn On

Table 2. Function Table of Switch 2:

EN	IN2	COM2	NEGATIVE CHARGE PUMP
0	X	COM2 is disconnected with NO2 and NC2	Turn Off
1	0	COM2 = NC2	Turn On
1	1	COM2 = NO2	Turn On

NOTE: X = Do not care.

PACKAGE INFORMATION

PACKAGE OUTLINE DIMENSIONS

TQFN-2.6×1.8-16L

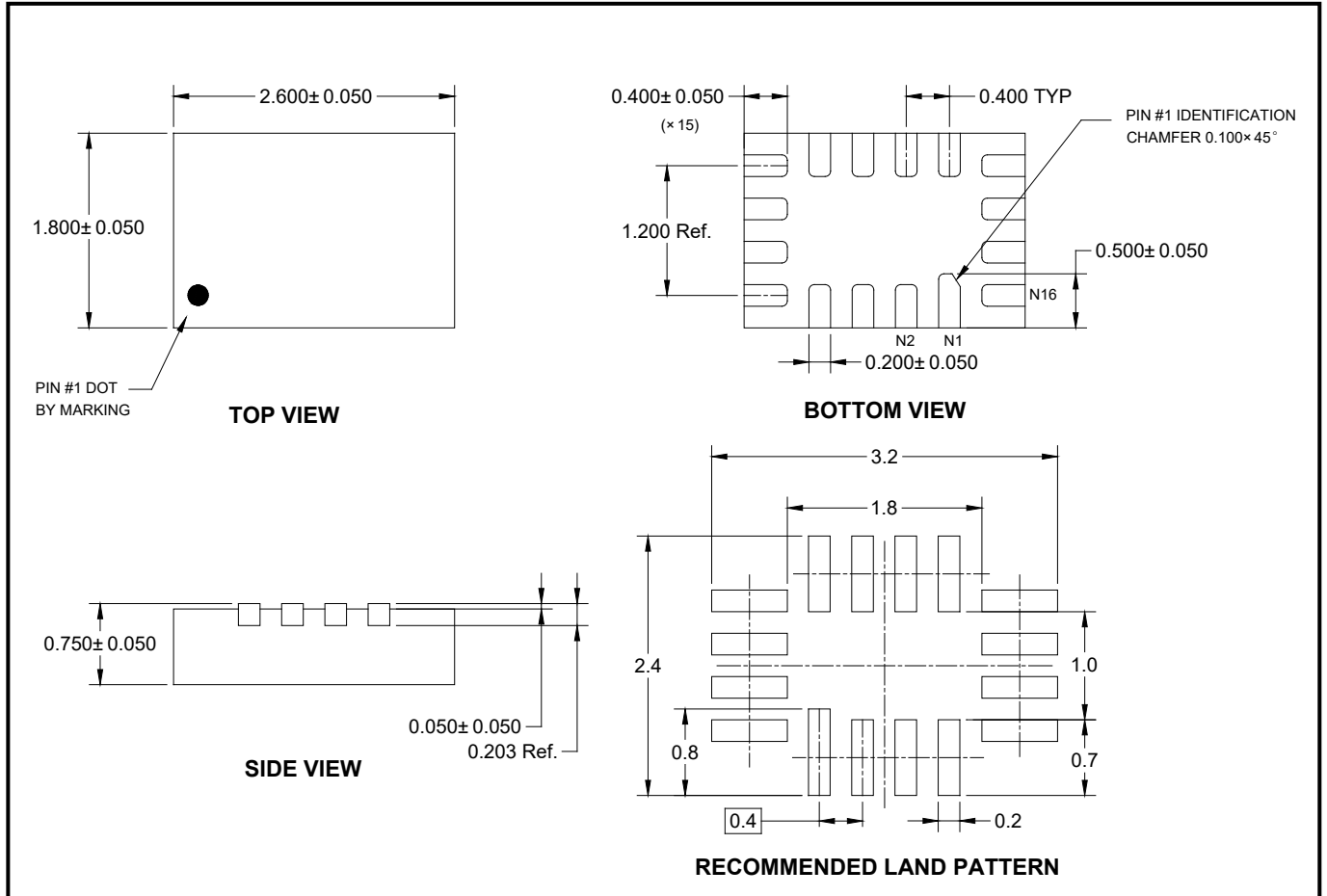

NOTES:

1. All linear dimensions are in millimeters.
2. This drawing is subject to change without notice.

TAPE AND REEL INFORMATION

REEL DIMENSIONS

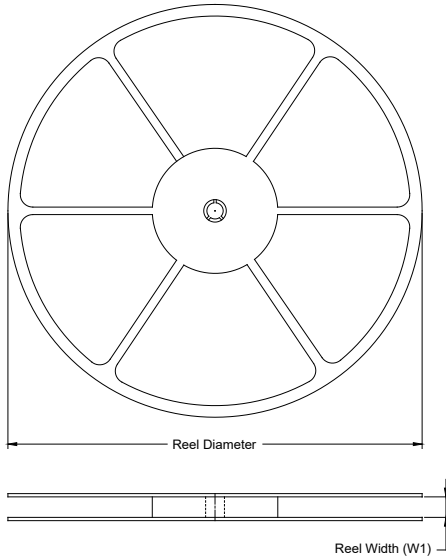

TAPE DIMENSIONS

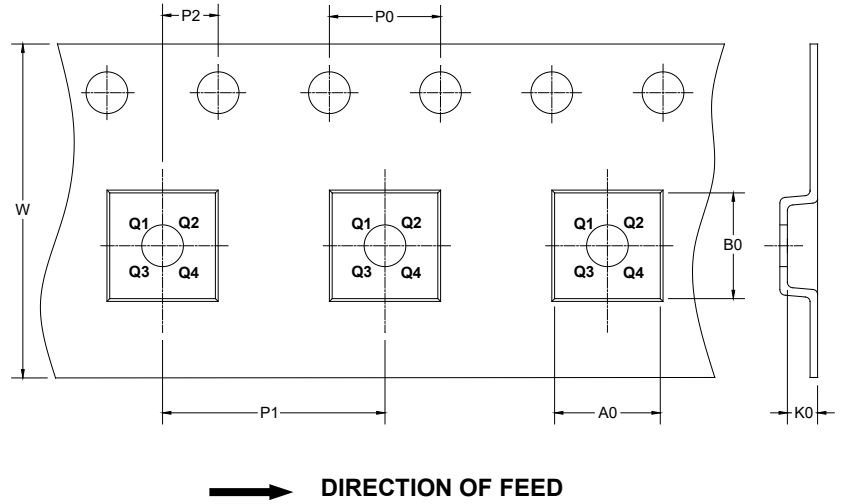

NOTE: The picture is only for reference. Please make the object as the standard.

KEY PARAMETER LIST OF TAPE AND REEL

Package Type	Reel Diameter	Reel Width W1 (mm)	A0 (mm)	B0 (mm)	K0 (mm)	P0 (mm)	P1 (mm)	P2 (mm)	W (mm)	Pin1 Quadrant
TQFN-2.6×1.8-16L	7"	9.0	2.01	2.81	0.93	4.0	4.0	2.0	8.0	Q1

DD0001

PACKAGE INFORMATION

CARTON BOX DIMENSIONS

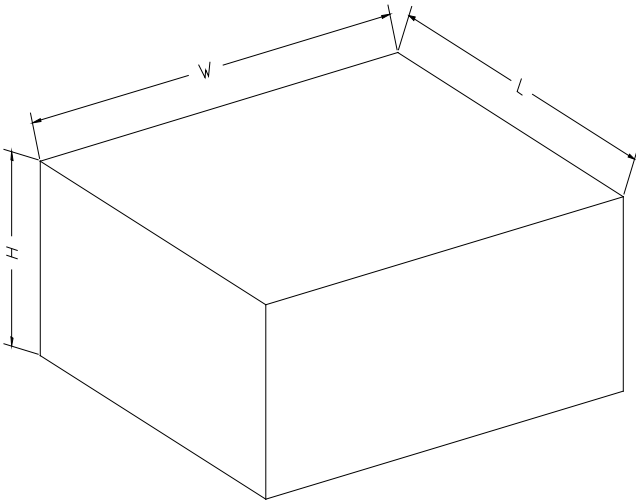

NOTE: The picture is only for reference. Please make the object as the standard.

KEY PARAMETER LIST OF CARTON BOX

Reel Type	Length (mm)	Width (mm)	Height (mm)	Pizza/Carton
7" (Option)	368	227	224	8
7"	442	410	224	18

D00002