



# SGM2068

## 500mA, Fast Transient Response, Low Voltage, Low Noise and Low Dropout Linear Regulator

### GENERAL DESCRIPTION

The SGM2068 is a CMOS, fast transient response, low voltage and low dropout voltage linear regulator. It is capable of supplying 500mA output current with typical dropout voltage of only 70mV. The operating input voltage range is from 1.5V to 5.5V. The fixed output voltage range is from 0.55V to 4.2V and adjustable output voltage range is from 0.55V to 5.0V.

Other features include logic-controlled shutdown mode, current limit and thermal shutdown protection. The SGM2068 has automatic discharge function to quickly discharge  $V_{OUT}$  in the disabled status.

The SGM2068 is available in Green SOT-23-5 and TDFN-2x2-6AL packages. It operates over an operating temperature range of  $-40^{\circ}\text{C}$  to  $+125^{\circ}\text{C}$ .

### APPLICATIONS

Portable Equipment  
Industrial and Medical Equipment

### FEATURES

- Operating Input Voltage Range: 1.5V to 5.5V
- Fixed Output from 0.55V to 4.2V
- Adjustable Output from 0.55V to 5.0V
- 500mA Output Current
- Output Voltage Accuracy:  $\pm 1\%$  at  $+25^{\circ}\text{C}$
- Quiescent Current: 85 $\mu\text{A}$  (TYP)
- Low Dropout Voltage:  
70mV (TYP) at 500mA,  $V_{OUT} = 3.3\text{V}$
- Low Noise: 16 $\mu\text{V}_{\text{RMS}}$  (TYP)
- Current Limiting and Thermal Protection
- Excellent Load and Line Transient Responses
- With Output Automatic Discharge
- UVLO with Hysteresis
- Stable with Small Case Size Ceramic Capacitors
- $-40^{\circ}\text{C}$  to  $+125^{\circ}\text{C}$  Operating Temperature Range
- Available in Green SOT-23-5 and TDFN-2x2-6AL Packages

### TYPICAL APPLICATION CIRCUITS

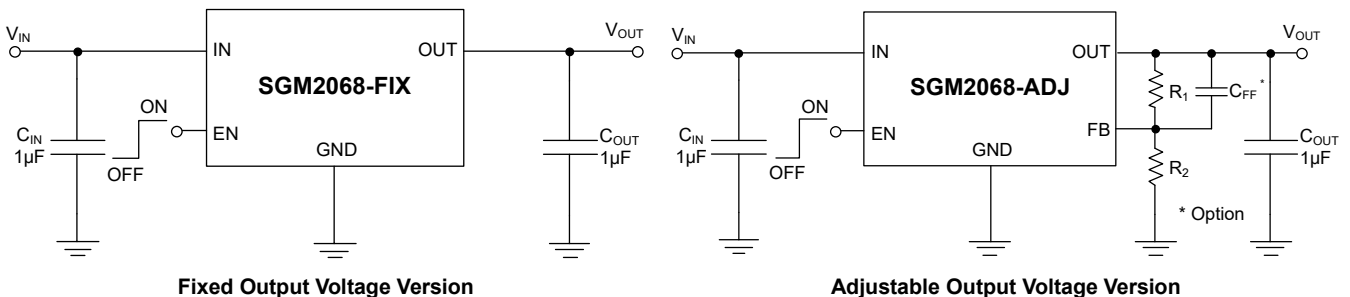

Figure 1. Typical Application Circuits

# 500mA, Fast Transient Response, Low Voltage, SGM2068 Low Noise and Low Dropout Linear Regulator

## PACKAGE/ORDERING INFORMATION

MODEL	PACKAGE DESCRIPTION	SPECIFIED TEMPERATURE RANGE	ORDERING NUMBER	PACKAGE MARKING	PACKING OPTION
SGM2068-0.8	SOT-23-5	-40°C to +125°C	SGM2068-0.8XN5G/TR	0S8XX	Tape and Reel, 3000
SGM2068-0.9	SOT-23-5	-40°C to +125°C	SGM2068-0.9XN5G/TR	0S9XX	Tape and Reel, 3000
SGM2068-1.2	SOT-23-5	-40°C to +125°C	SGM2068-1.2XN5G/TR	0SDXX	Tape and Reel, 3000
SGM2068-1.5	SOT-23-5	-40°C to +125°C	SGM2068-1.5XN5G/TR	1SVXX	Tape and Reel, 3000
SGM2068-1.8	SOT-23-5	-40°C to +125°C	SGM2068-1.8XN5G/TR	0SEXXX	Tape and Reel, 3000
SGM2068-2.5	SOT-23-5	-40°C to +125°C	SGM2068-2.5XN5G/TR	0SFXX	Tape and Reel, 3000
SGM2068-2.8	SOT-23-5	-40°C to +125°C	SGM2068-2.8XN5G/TR	0SGXX	Tape and Reel, 3000
SGM2068-3.0	SOT-23-5	-40°C to +125°C	SGM2068-3.0XN5G/TR	0SHXX	Tape and Reel, 3000
SGM2068-3.3	SOT-23-5	-40°C to +125°C	SGM2068-3.3XN5G/TR	0SIXX	Tape and Reel, 3000
SGM2068-ADJ	SOT-23-5	-40°C to +125°C	SGM2068-ADJXN5G/TR	0EUXXX	Tape and Reel, 3000
SGM2068-0.8	TDFN-2x2-6AL	-40°C to +125°C	SGM2068-0.8XTDI6G/TR	0SK XXXX	Tape and Reel, 3000
SGM2068-0.9	TDFN-2x2-6AL	-40°C to +125°C	SGM2068-0.9XTDI6G/TR	0SL XXXX	Tape and Reel, 3000
SGM2068-1.2	TDFN-2x2-6AL	-40°C to +125°C	SGM2068-1.2XTDI6G/TR	0SP XXXX	Tape and Reel, 3000
SGM2068-1.5	TDFN-2x2-6AL	-40°C to +125°C	SGM2068-1.5XTDI6G/TR	1SW XXXX	Tape and Reel, 3000
SGM2068-1.8	TDFN-2x2-6AL	-40°C to +125°C	SGM2068-1.8XTDI6G/TR	0SQ XXXX	Tape and Reel, 3000
SGM2068-2.5	TDFN-2x2-6AL	-40°C to +125°C	SGM2068-2.5XTDI6G/TR	0SR XXXX	Tape and Reel, 3000
SGM2068-2.8	TDFN-2x2-6AL	-40°C to +125°C	SGM2068-2.8XTDI6G/TR	0SS XXXX	Tape and Reel, 3000
SGM2068-3.0	TDFN-2x2-6AL	-40°C to +125°C	SGM2068-3.0XTDI6G/TR	0ST XXXX	Tape and Reel, 3000
SGM2068-3.3	TDFN-2x2-6AL	-40°C to +125°C	SGM2068-3.3XTDI6G/TR	0SU XXXX	Tape and Reel, 3000
SGM2068-ADJ	TDFN-2x2-6AL	-40°C to +125°C	SGM2068-ADJXTDI6G/TR	0EQ XXXX	Tape and Reel, 3000

## MARKING INFORMATION

NOTE: XX = Date Code. XXXX = Date Code, Trace Code and Vendor Code.

### SOT-23-5

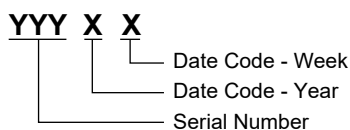

### TDFN-2x2-6AL

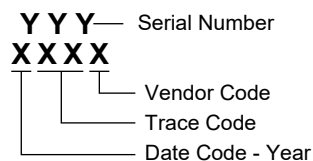

Green (RoHS & HSF): SG Micro Corp defines "Green" to mean Pb-Free (RoHS compatible) and free of halogen substances. If you have additional comments or questions, please contact your SGMICRO representative directly.

**ABSOLUTE MAXIMUM RATINGS**

IN to GND .....	-0.3V to 6V
OUT, FB to GND.....	-0.3V to ( $V_{IN} + 0.3V$ )
EN to GND.....	-0.3V to 6V
Package Thermal Resistance	
SOT-23-5, $\theta_{JA}$ .....	181°C/W
SOT-23-5, $\theta_{JB}$ .....	39°C/W
SOT-23-5, $\theta_{JC}$ .....	74°C/W
TDFN-2x2-6AL, $\theta_{JA}$ .....	70°C/W
TDFN-2x2-6AL, $\theta_{JB}$ .....	34°C/W
TDFN-2x2-6AL, $\theta_{JC(TOP)}$ .....	50°C/W
TDFN-2x2-6AL, $\theta_{JC(BOT)}$ .....	15°C/W
Junction Temperature .....	+150°C
Storage Temperature Range.....	-65°C to +150°C
Lead Temperature (Soldering, 10s) .....	+260°C
ESD Susceptibility	
HBM.....	±8000V
CDM .....	±1000V

**RECOMMENDED OPERATING CONDITIONS**

Input Voltage Range .....	1.5V to 5.5V
Enable Input Voltage Range .....	0V to 5.5V
Input Effective Capacitance, $C_{IN}$ .....	0.5µF (MIN)
Output Effective Capacitance, $C_{OUT}$ .....	0.5µF to 220µF
Operating Junction Temperature Range.....	-40°C to +125°C

**OVERSTRESS CAUTION**

Stresses beyond those listed in Absolute Maximum Ratings may cause permanent damage to the device. Exposure to absolute maximum rating conditions for extended periods may affect reliability. Functional operation of the device at any conditions beyond those indicated in the Recommended Operating Conditions section is not implied.

**ESD SENSITIVITY CAUTION**

This integrated circuit can be damaged if ESD protections are not considered carefully. SGMICRO recommends that all integrated circuits be handled with appropriate precautions. Failure to observe proper handling and installation procedures can cause damage. ESD damage can range from subtle performance degradation to complete device failure. Precision integrated circuits may be more susceptible to damage because even small parametric changes could cause the device not to meet the published specifications.

**DISCLAIMER**

SG Micro Corp reserves the right to make any change in circuit design, or specifications without prior notice.

PIN CONFIGURATIONS

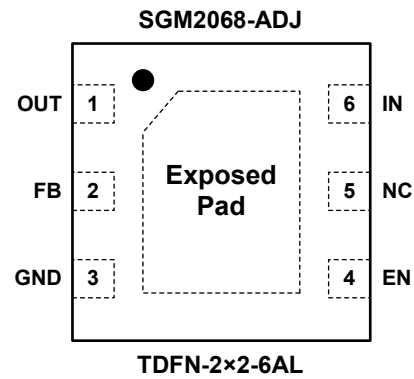
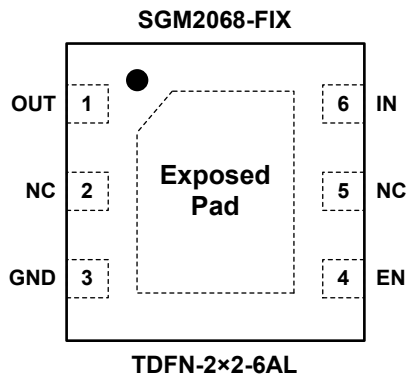
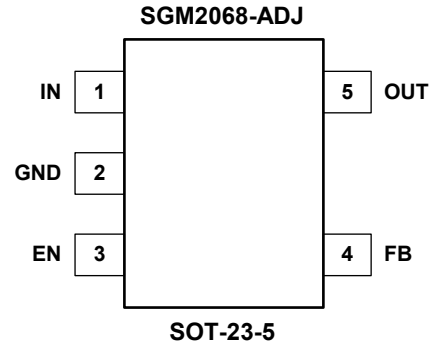
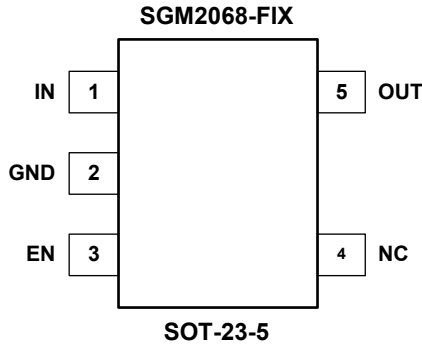

PIN DESCRIPTION

PIN		NAME	FUNCTION
SOT-23-5	TDFN-2x2-6AL		
1	6	IN	Input Supply Voltage Pin. It is recommended to use a 1µF or larger ceramic capacitor from IN pin to ground to get good power supply decoupling. This ceramic capacitor should be placed as close as possible to IN pin.
2	3	GND	Ground.
3	4	EN	Enable Pin. Drive EN high or leave it floating to turn on the regulator. Drive EN low to turn off the regulator.
4	2	NC	No Connection (fixed voltage version only).
		FB	Feedback Pin (adjustable voltage version only). Connect this pin to the midpoint of an external resistor divider to adjust the output voltage. Place the resistors as close as possible to this pin.
5	1	OUT	Regulator Output Pin. It is recommended to use a ceramic capacitor with effective capacitance in the range of 0.5µF to 220µF to ensure stability. This ceramic capacitor should be placed as close as possible to OUT pin.
—	5	NC	No Connection.
—	Exposed Pad	—	Exposed Pad. Connect it to GND internally. Connect it to a large ground plane to maximize thermal performance. This pad is not an electrical connection point.

**FUNCTIONAL BLOCK DIAGRAMS**

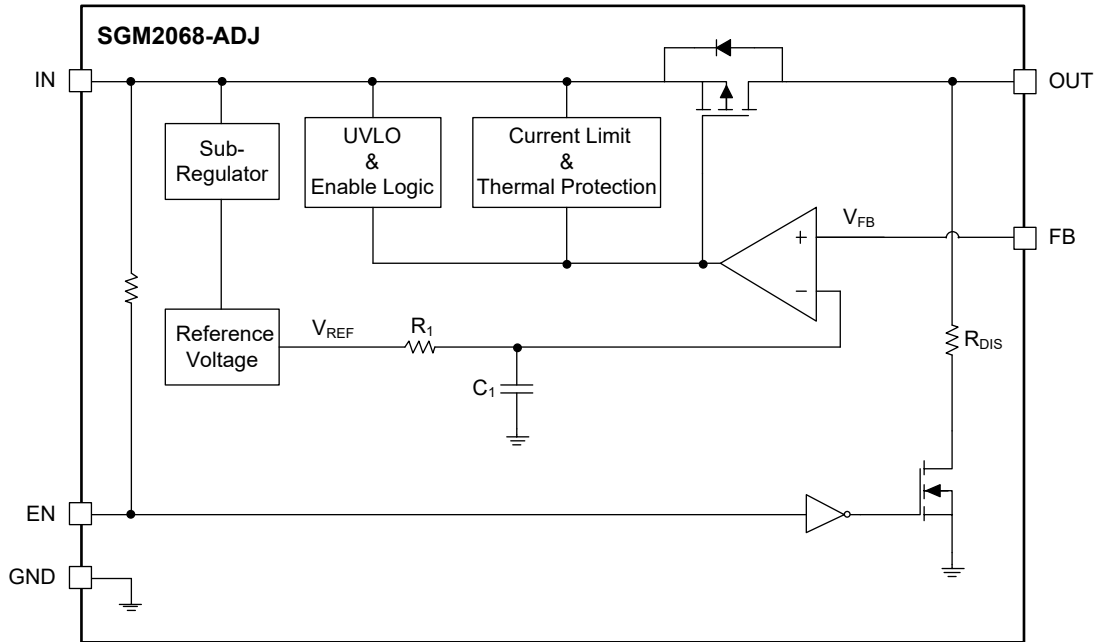

**Figure 2. Block Diagram for Adjustable Output Version**

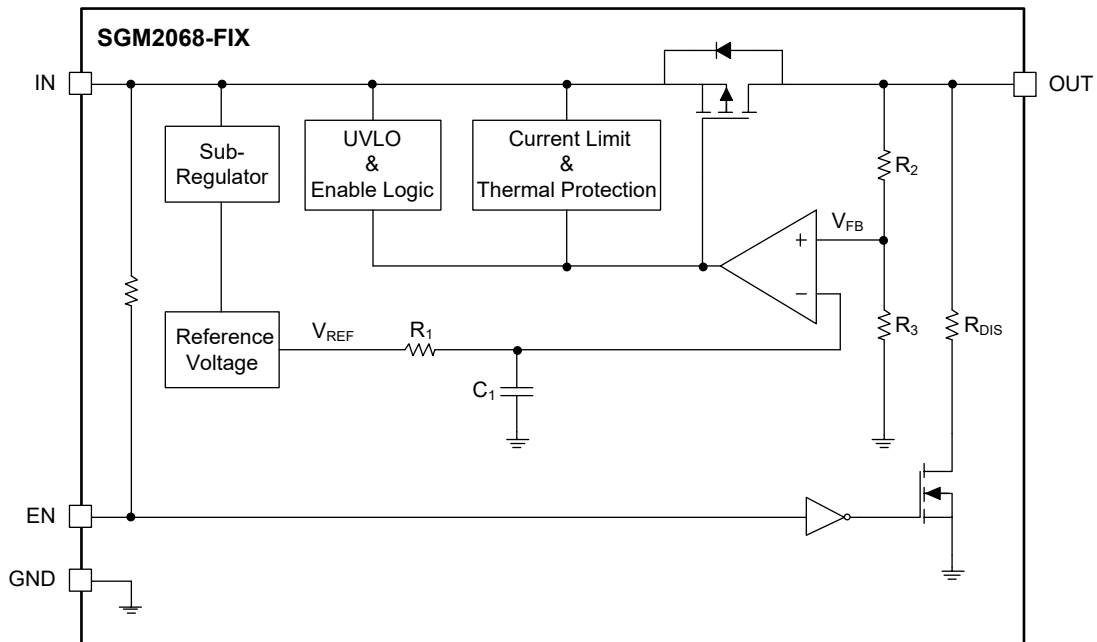

**Figure 3. Block Diagram for Fixed Output Version**

# 500mA, Fast Transient Response, Low Voltage, SGM2068 Low Noise and Low Dropout Linear Regulator

## ELECTRICAL CHARACTERISTICS

( $V_{IN} = (V_{OUT(NOM)} + 0.5V)$  or 1.5V (whichever is greater),  $C_{IN} = 1\mu F$ ,  $C_{OUT} = 1\mu F$ ,  $T_J = -40^\circ C$  to  $+125^\circ C$ , typical values are at  $T_J = +25^\circ C$ , unless otherwise noted.)

PARAMETER	SYMBOL	CONDITIONS	MIN	TYP	MAX	UNITS	
Input Supply Voltage Range	$V_{IN}$		1.5		5.5	V	
Output Voltage Range	$V_{OUT}$	SGM2068-FIX	0.8		4.2	V	
		SGM2068-ADJ	0.55		5		
Reference Voltage	$V_{FB}$	$V_{IN} = (V_{OUT(NOM)} + 0.5V)$ to 5.5V, $I_{OUT} = 10mA$	$T_J = +25^\circ C$	0.5445	0.55	0.5555	V
			$T_J = -40^\circ C$ to $+125^\circ C$	0.5401	0.55	0.5583	
Output Voltage Accuracy	$V_{OUT}$	$V_{IN} = (V_{OUT(NOM)} + 0.5V)$ to 5.5V, $I_{OUT} = 10mA$	$T_J = +25^\circ C$	-1		1	%
			$T_J = -40^\circ C$ to $+125^\circ C$	-1.8		1.5	
FB Pin Input Current	$I_{FB}$			0.1	50	nA	
Under-Voltage Lockout	$V_{UVLO}$	$V_{IN}$ rising		1.35	1.43	V	
		$V_{IN}$ falling	1.2	1.28			
Line Regulation	$\Delta V_{OUT\_LNR}$	$V_{IN} = (V_{OUT(NOM)} + 0.5V)$ to 5.5V, $I_{OUT} = 0.1mA$		2.5	15	mV	
Load Regulation	$\Delta V_{OUT\_LNR}$	$I_{OUT} = 0.1mA$ to 500mA		2.5	10	mV	
Dropout Voltage	$V_{DROP}$	$I_{OUT} = 500mA$ , when $V_{OUT}$ falls to $95\% \times V_{OUT(NOM)}$	$V_{OUT(NOM)} = 0.55V$		840	1000	mV
			$V_{OUT(NOM)} = 0.8V$		620	750	
			$V_{OUT(NOM)} = 0.9V$		530	650	
			$V_{OUT(NOM)} = 1.2V$		300	450	
			$V_{OUT(NOM)} = 1.8V$		125	195	
			$V_{OUT(NOM)} = 2.5V$		85	150	
			$V_{OUT(NOM)} = 2.8V$		80	130	
			$V_{OUT(NOM)} = 3V$		75	125	
			$V_{OUT(NOM)} = 3.3V$		70	115	
$V_{OUT(NOM)} = 5.0V$		55	95				
Output Current Limit	$I_{LIMIT}$	$V_{IN} = (V_{OUT(NOM)} + 2V)$ , $V_{OUT} = 90\% \times V_{OUT(NOM)}$	0.55	1.1		A	
Output Short-Circuit Current	$I_{SHORT}$	$V_{IN} = (V_{OUT(NOM)} + 2V)$ , $V_{OUT} = 0V$		300		mA	
Quiescent Current	$I_Q$	$I_{OUT} = 0mA$		85	350	$\mu A$	
Shutdown Current	$I_{SHDN}$	$V_{EN} = 0V$		0.25	2.5	$\mu A$	
Enable Threshold Voltage	$V_{IH}$	EN input voltage high	1.0			V	
	$V_{IL}$	EN input voltage low			0.4		
Enable Input Current	$I_{EN}$	$V_{EN} = 0V$ , $V_{IN} = 5.5V$		210	300	$\mu A$	
		$V_{EN} = 5.5V$ , $V_{IN} = 5.5V$		0.01	1	$\mu A$	
Output Discharge Resistance	$R_{DIS}$	$V_{EN} = 0V$ , $V_{IN} = 5.5V$		75		$\Omega$	
Turn-On Time	$t_{ON}$	From assertion of $V_{EN}$ to $V_{OUT} = 90\% \times V_{OUT(NOM)}$		450	830	$\mu s$	
Power Supply Rejection Ratio	PSRR	$V_{OUT} = 0.55V$ , $V_{IN} = 1.5V$ , Ripple 0.2V <sub>P-P</sub> , $I_{OUT} = 50mA$ , $C_{OUT} = 2.2\mu F$	$f = 1kHz$	50		dB	
			$f = 100kHz$	36			
			$f = 1MHz$	26			
		$V_{OUT} = 3.3V$ , $V_{IN} = 3.8V$ , Ripple 0.2V <sub>P-P</sub> , $I_{OUT} = 50mA$ , $C_{OUT} = 2.2\mu F$	$f = 1kHz$	60			
			$f = 100kHz$	41			
			$f = 1MHz$	28			
Output Voltage Noise	$e_n$	$V_{OUT} = 0.55V$ , $V_{IN} = 1.5V$ , $C_{OUT} = 2.2\mu F$ , $f = 10Hz$ to 100kHz	$I_{OUT} = 1mA$	25		$\mu V_{RMS}$	
			$I_{OUT} = 500mA$	16			
		$V_{OUT} = 3.3V$ , $V_{IN} = 3.8V$ , $C_{OUT} = 2.2\mu F$ , $f = 10Hz$ to 100kHz	$I_{OUT} = 1mA$	59			
			$I_{OUT} = 500mA$	54			
Thermal Shutdown Temperature	$T_{SHDN}$	$T_J$ rising		155		$^\circ C$	
Thermal Shutdown Hysteresis	$\Delta T_{SHDN}$	Hysteresis		15		$^\circ C$	

# SGM2068 500mA, Fast Transient Response, Low Voltage, Low Noise and Low Dropout Linear Regulator

## TYPICAL PERFORMANCE CHARACTERISTICS

$T_J = +25^\circ\text{C}$ ,  $V_{IN} = (V_{OUT(NOM)} + 0.5\text{V})$  or  $1.5\text{V}$  (whichever is greater),  $V_{EN} = V_{IN}$ ,  $C_{IN} = 1\mu\text{F}$ ,  $C_{OUT} = 1\mu\text{F}$ , unless otherwise noted.

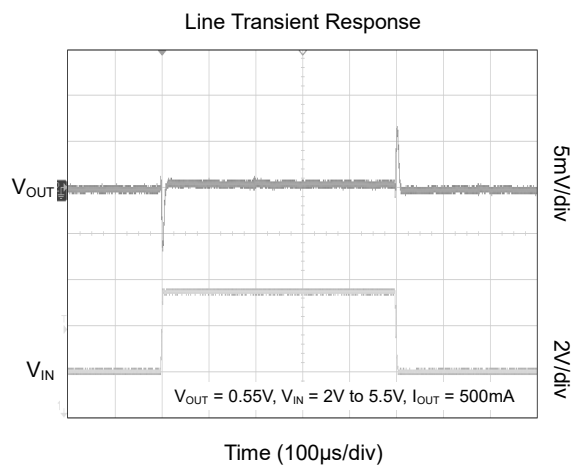
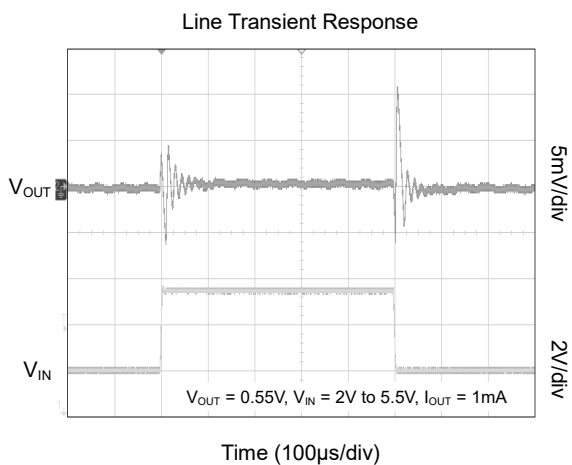
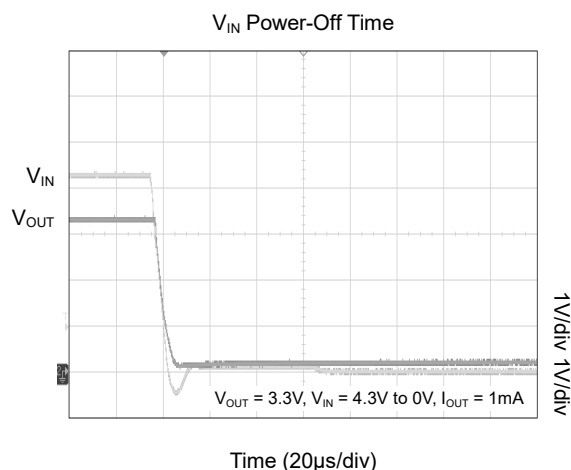
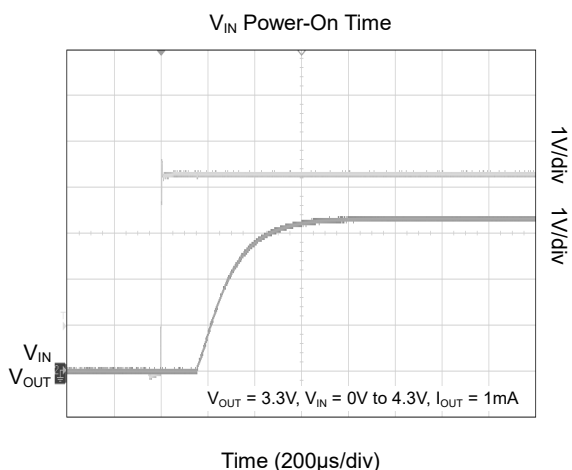
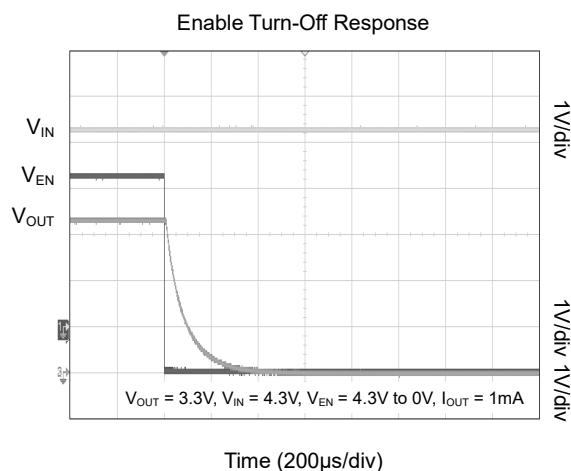
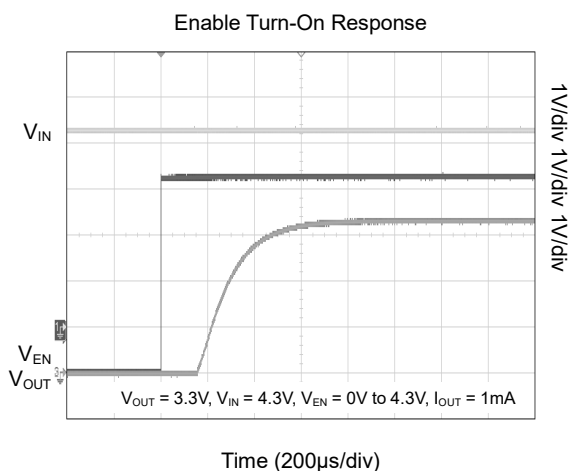

TYPICAL PERFORMANCE CHARACTERISTICS (continued)

$T_J = +25^{\circ}\text{C}$ ,  $V_{IN} = (V_{OUT(NOM)} + 0.5\text{V})$  or  $1.5\text{V}$  (whichever is greater),  $V_{EN} = V_{IN}$ ,  $C_{IN} = 1\mu\text{F}$ ,  $C_{OUT} = 1\mu\text{F}$ , unless otherwise noted.

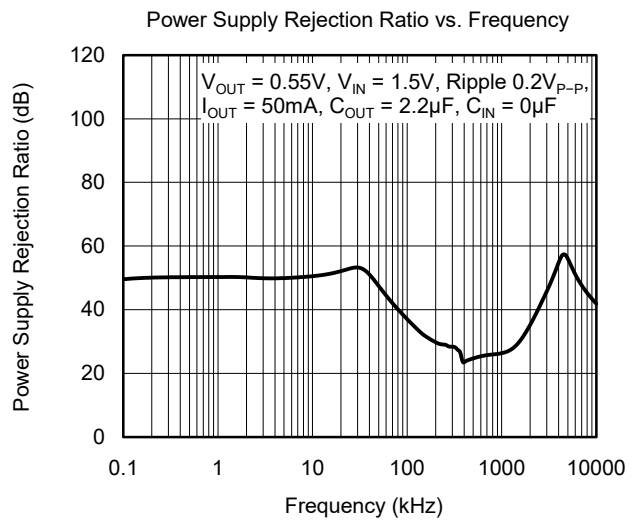
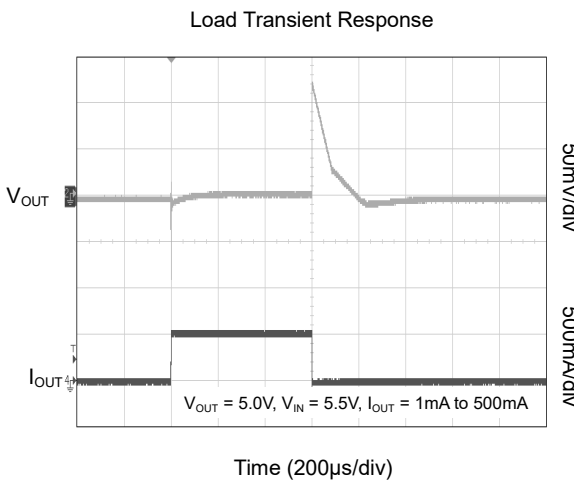
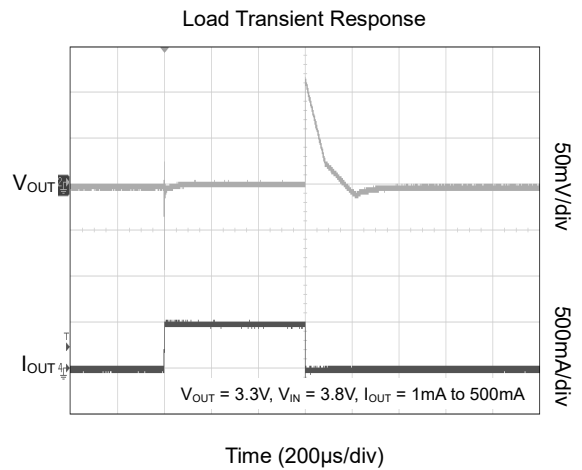
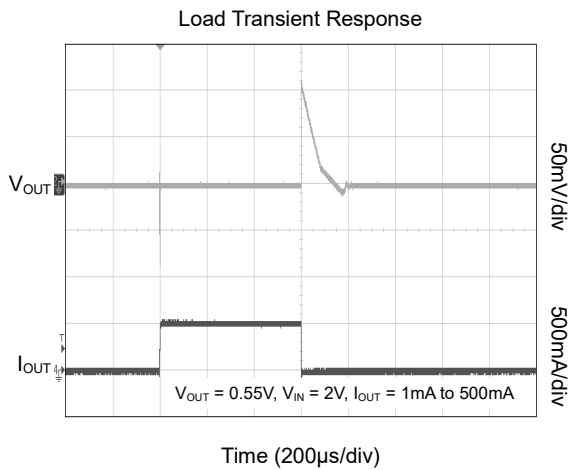
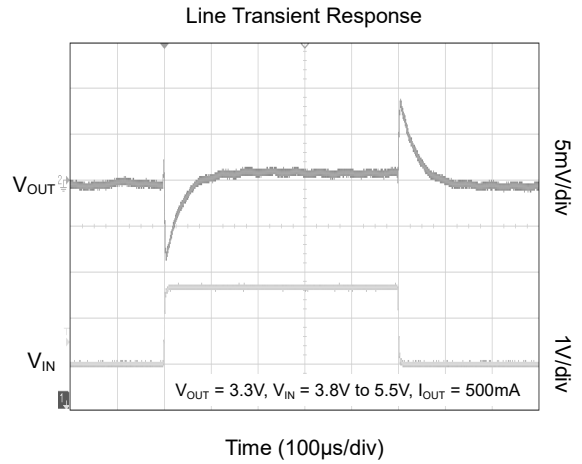
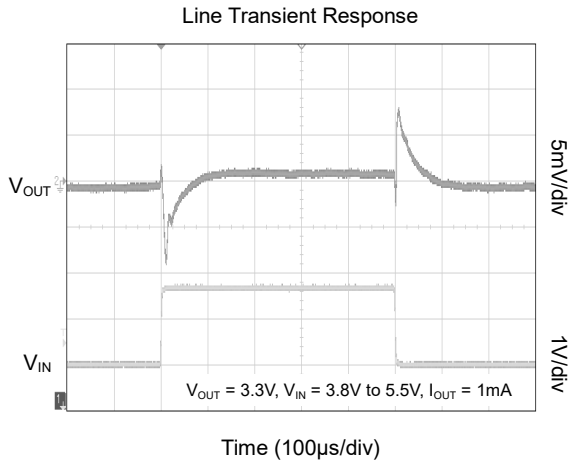

# SGM2068 500mA, Fast Transient Response, Low Voltage, Low Noise and Low Dropout Linear Regulator

## TYPICAL PERFORMANCE CHARACTERISTICS (continued)

$T_J = +25^\circ\text{C}$ ,  $V_{IN} = (V_{OUT(NOM)} + 0.5\text{V})$  or  $1.5\text{V}$  (whichever is greater),  $V_{EN} = V_{IN}$ ,  $C_{IN} = 1\mu\text{F}$ ,  $C_{OUT} = 1\mu\text{F}$ , unless otherwise noted.

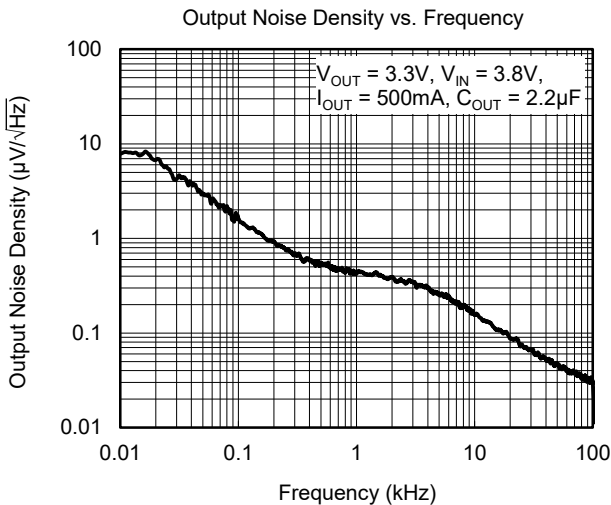
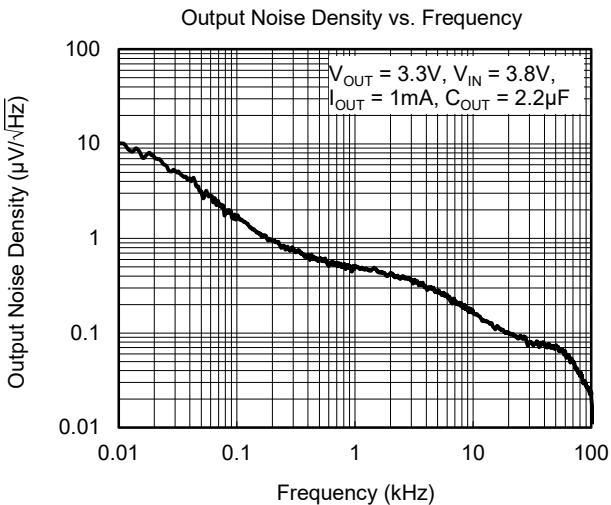
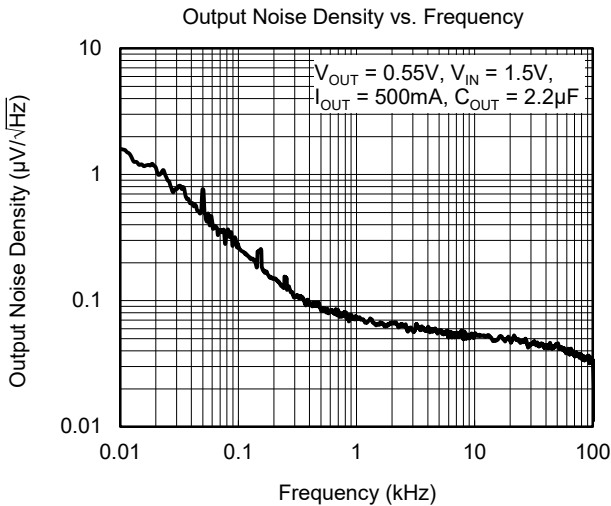
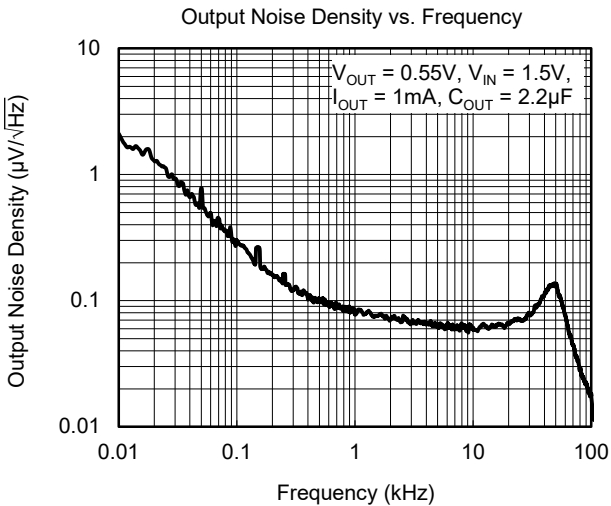
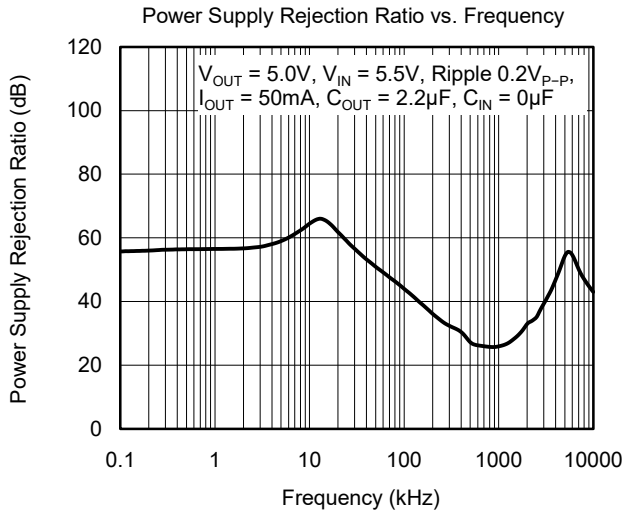
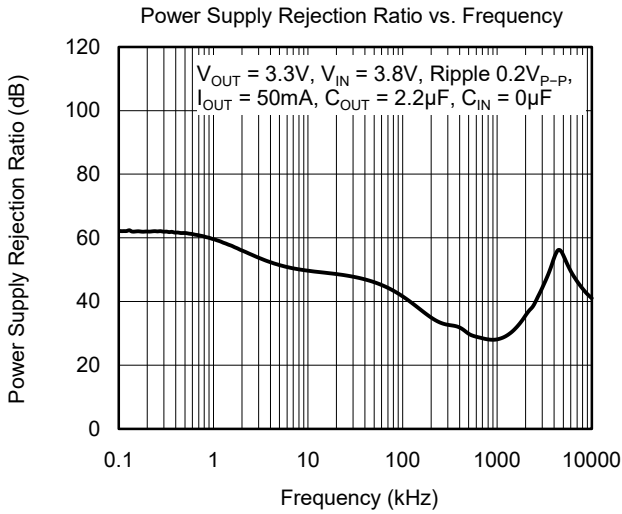

# SGM2068 500mA, Fast Transient Response, Low Voltage, Low Noise and Low Dropout Linear Regulator

## TYPICAL PERFORMANCE CHARACTERISTICS (continued)

$T_J = +25^\circ\text{C}$ ,  $V_{IN} = (V_{OUT(NOM)} + 0.5\text{V})$  or  $1.5\text{V}$  (whichever is greater),  $V_{EN} = V_{IN}$ ,  $C_{IN} = 1\mu\text{F}$ ,  $C_{OUT} = 1\mu\text{F}$ , unless otherwise noted.

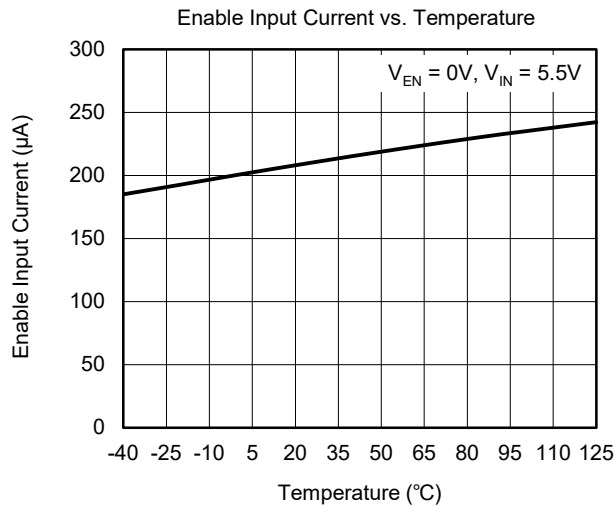
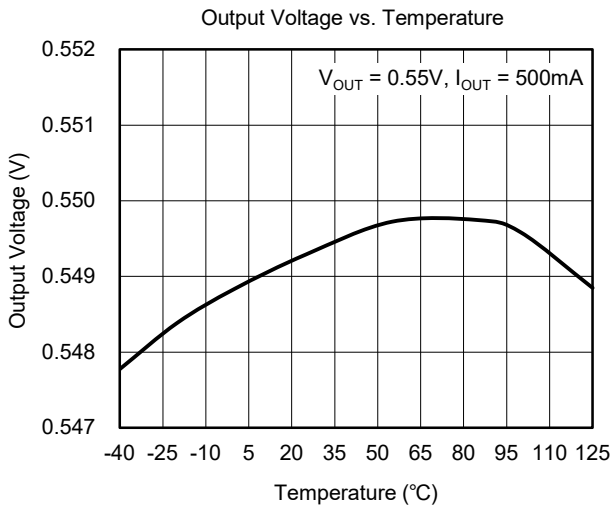
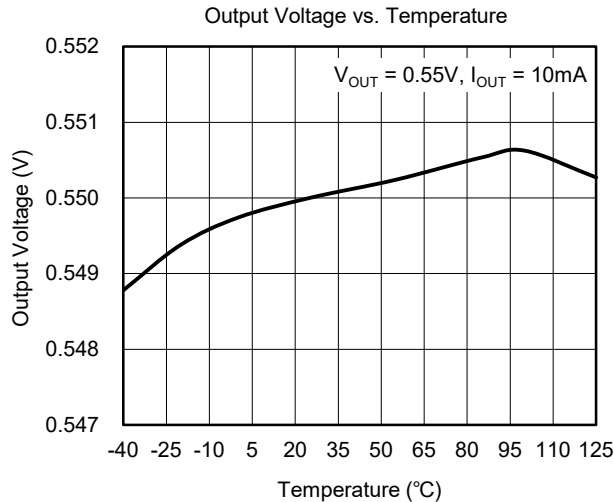
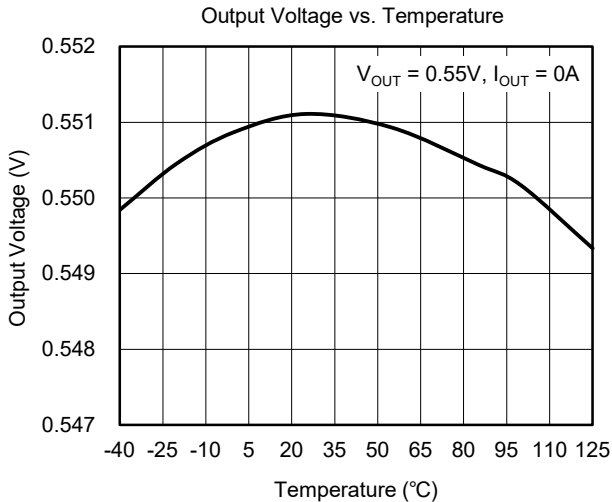
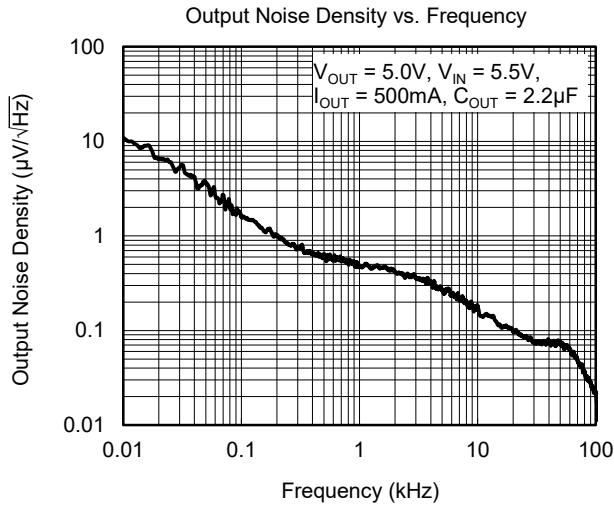
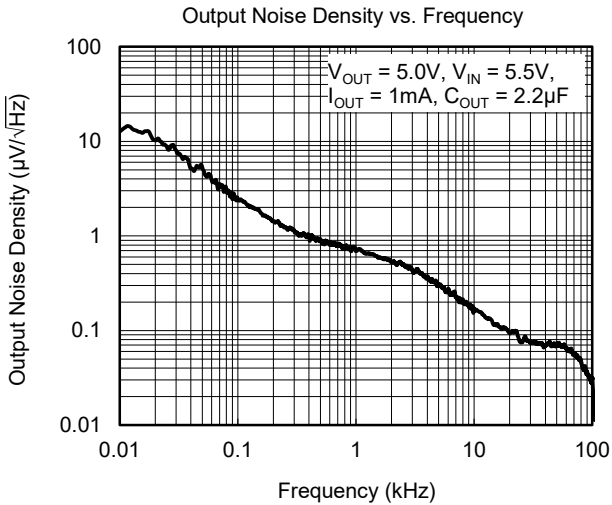

# SGM2068 500mA, Fast Transient Response, Low Voltage, Low Noise and Low Dropout Linear Regulator

## TYPICAL PERFORMANCE CHARACTERISTICS (continued)

$T_J = +25^\circ\text{C}$ ,  $V_{IN} = (V_{OUT(NOM)} + 0.5\text{V})$  or  $1.5\text{V}$  (whichever is greater),  $V_{EN} = V_{IN}$ ,  $C_{IN} = 1\mu\text{F}$ ,  $C_{OUT} = 1\mu\text{F}$ , unless otherwise noted.

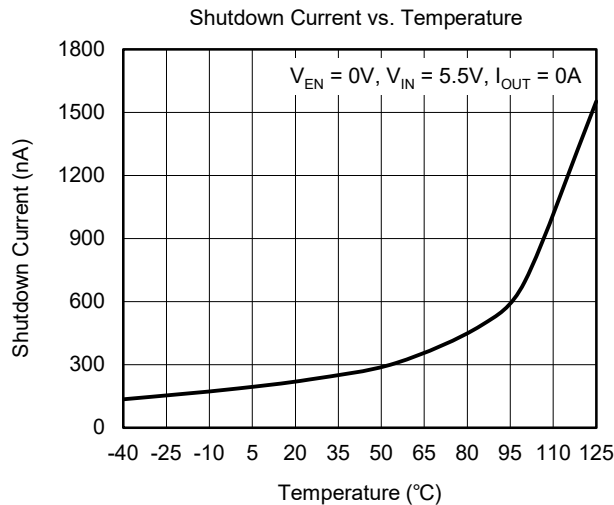
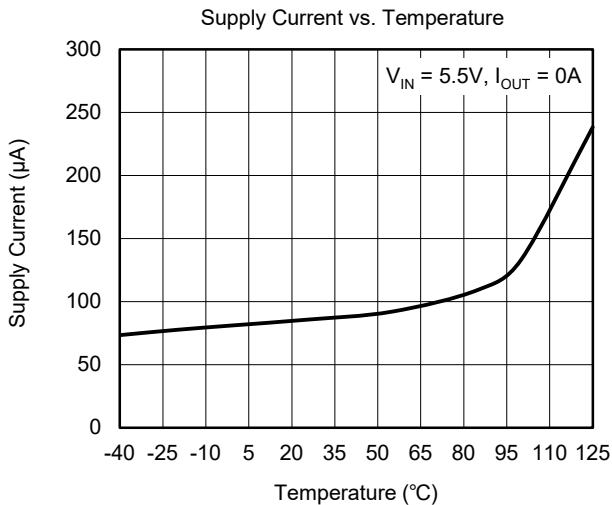
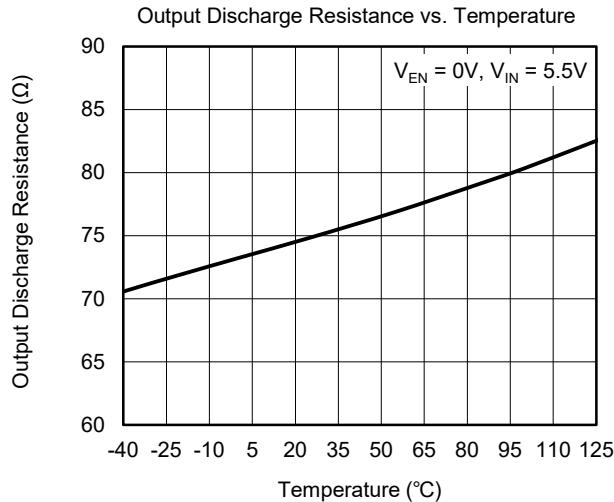
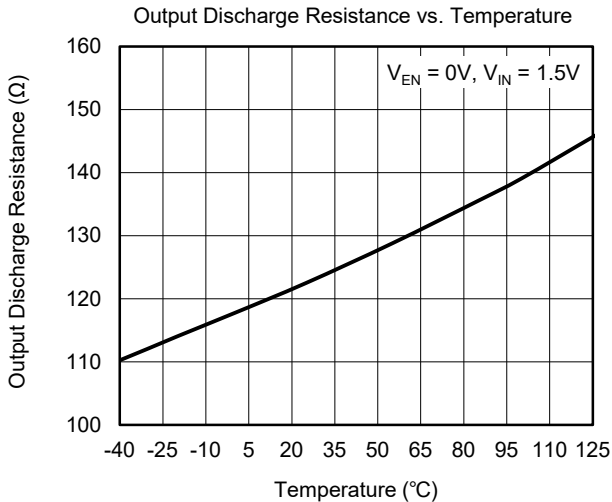
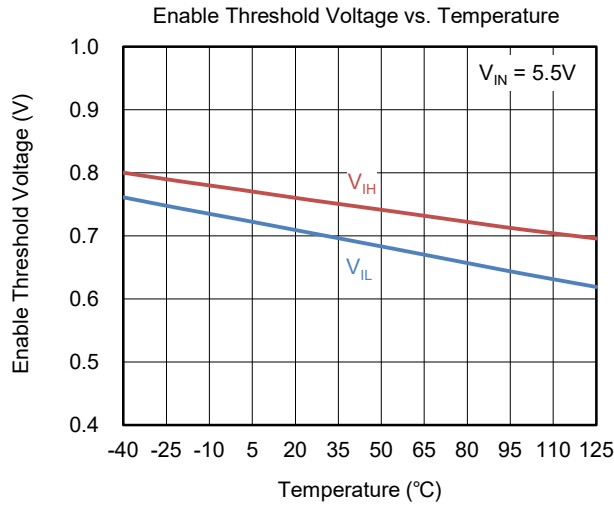
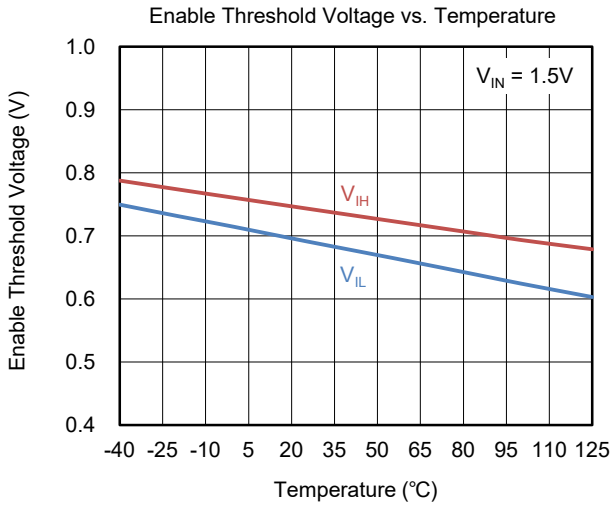

# SGM2068 500mA, Fast Transient Response, Low Voltage, Low Noise and Low Dropout Linear Regulator

## TYPICAL PERFORMANCE CHARACTERISTICS (continued)

$T_J = +25^\circ\text{C}$ ,  $V_{IN} = (V_{OUT(NOM)} + 0.5\text{V})$  or  $1.5\text{V}$  (whichever is greater),  $V_{EN} = V_{IN}$ ,  $C_{IN} = 1\mu\text{F}$ ,  $C_{OUT} = 1\mu\text{F}$ , unless otherwise noted.

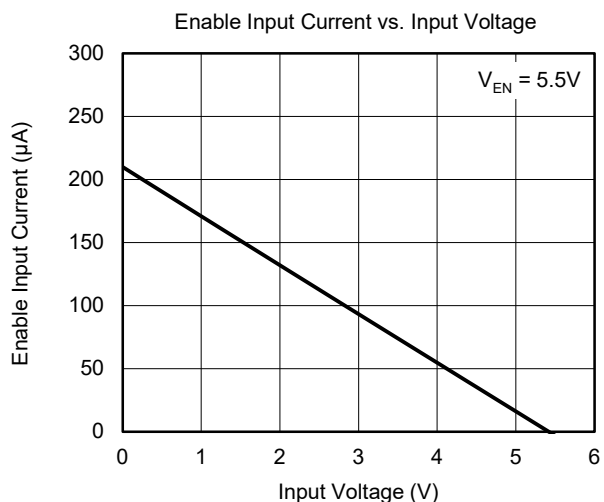
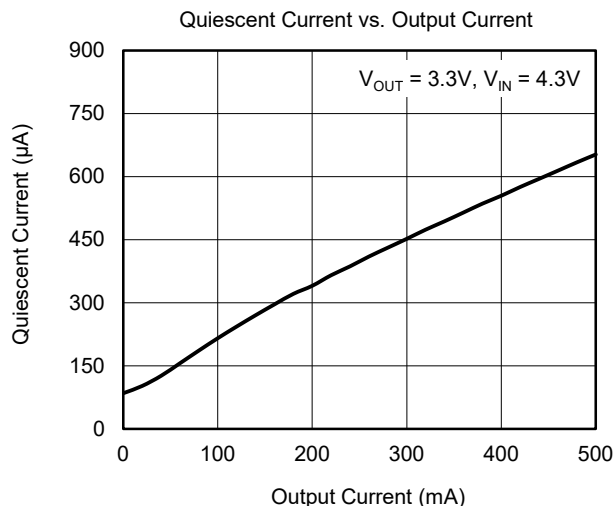
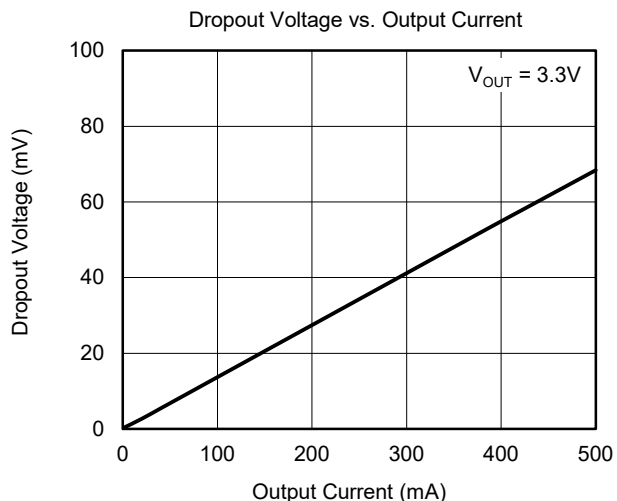
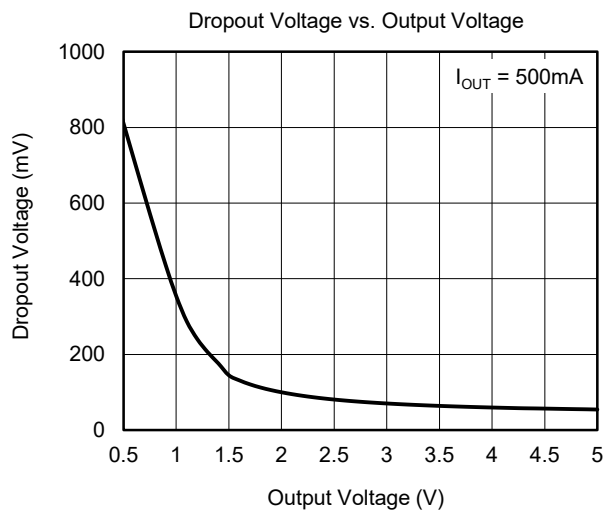
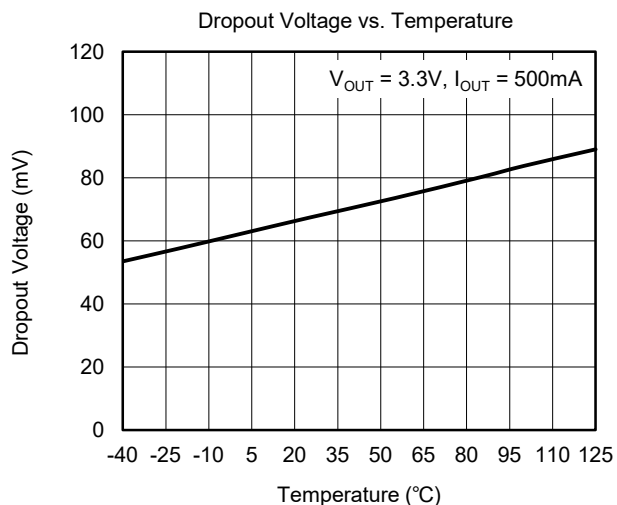

APPLICATION INFORMATION

The SGM2068 is a low noise and low dropout LDO and provides 500mA output current. These features make the device a reliable solution to solve many challenging problems in the generation of clean and accurate power supply. The high performance also makes the SGM2068 useful in a variety of applications. The SGM2068 provides protection functions for output overload, output short-circuit condition and overheating.

The SGM2068 provides an EN pin as an external chip enable control to enable/disable the device. When the regulator is in shutdown state, the shutdown current consumes as low as 0.25µA (TYP).

Input Capacitor Selection (C<sub>IN</sub>)

The input decoupling capacitor should be placed as close as possible to the IN pin to ensure the device stability. 1µF or larger X7R or X5R ceramic capacitor is selected to get good dynamic performance.

When V<sub>IN</sub> is required to provide large current instantaneously, a large effective input capacitor is required. Multiple input capacitors can limit the input tracking inductance. Adding more input capacitors is available to restrict the ringing and to keep it below the device absolute maximum ratings.

Output Capacitor Selection (C<sub>OUT</sub>)

One or more output capacitors are required to maintain the stability of the LDO, and the output capacitors should be placed as close as possible to the OUT pin. In addition, in order to obtain the best transient performance, it is recommended to use X7R and X5R ceramic capacitors as output capacitors. Ceramic capacitors have low equivalent series resistance (ESR), excellent temperature and DC bias characteristics. However, it cannot be ignored that the effective capacitance of ceramic capacitors is affected by temperature, DC bias and package size.

For example, Figure 4 shows the capacitance and DC bias and temperature characteristics of 0805, 10V, 10µF±10%, X7R capacitor. Therefore, it is necessary to evaluate whether the effective capacitance of the output capacitor can meet the stability requirements of the LDO in practical applications. In general, a capacitor in higher voltage rating and a larger package exhibits better stability, and the effective capacitance can be obtained from the manufacturer datasheet.

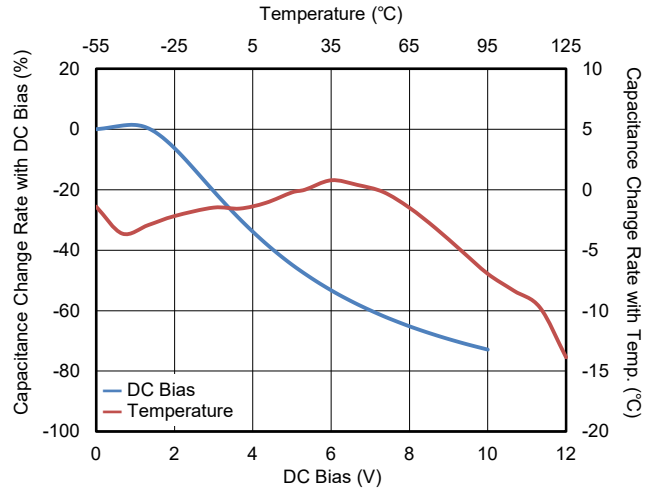

Figure 4. Capacitance vs. DC Bias and Temperature Characteristics

The SGM2068 requires a minimum effective capacitance of 0.5µF for C<sub>OUT</sub> to ensure stability. Additionally, C<sub>OUT</sub> with larger capacitance and lower ESR will help increase the high frequency PSRR and improve the load transient response.

Adjustable Regulator

The output voltage of the SGM2068-ADJ can be adjusted from 0.55V to 5.0V. The FB pin will be connected to two external resistors as shown in Figure 5. The output voltage is determined by the following equation:

$$V_{OUT} = V_{FB} \times \left( 1 + \frac{R_1}{R_2} \right) \tag{1}$$

where:

V<sub>OUT</sub> is output voltage and V<sub>FB</sub> is the internal voltage reference, V<sub>FB</sub> = 0.55V.

One parallel capacitor (C<sub>FF</sub>) with R<sub>1</sub> can be used to improve the PSRR, increase the transient response and reduce the output noise. The resistance range of R<sub>2</sub> is recommended to be between 5kΩ and 130kΩ.

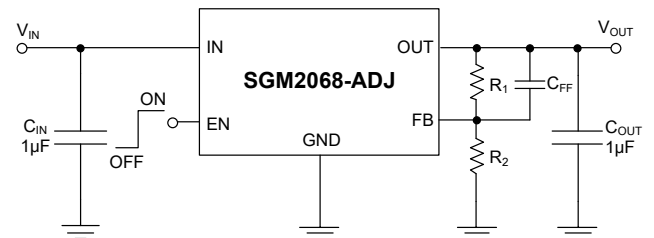

Figure 5. Adjustable Output Voltage Application

**APPLICATION INFORMATION (continued)****Enable Operation**

The SGM2068 uses the EN pin to enable/disable the device and to deactivate/activate the output automatic discharge function. The EN pin has a 26k $\Omega$  (TYP) pull-up resistance to the power supply.

When the EN pin voltage is lower than 0.4V, the device is in shutdown state. There is no current flowing from IN to OUT pins. In this state, the automatic discharge transistor is active to discharge the output voltage through a 75 $\Omega$  (TYP) resistor.

When the EN pin voltage is higher than 1.0V or the EN pin is floated, the device is in active state. The output voltage is regulated to the expected value and the automatic discharge transistor is turned off.

**Under-Voltage Lockout (UVLO)**

The UVLO circuit monitors the input voltage to prevent the device from turning on before  $V_{IN}$  rises above the  $V_{UVLO}$  threshold. The UVLO circuit responds quickly to glitches on the IN pin and attempts to disable the output of the device if any of these rails collapses. The local input capacitance prevents severe brownouts in most applications.

**Output Current Limit Protection**

When overload events happen, the output current is internally limited to 1.1A (TYP). When the OUT pin is shorted to ground, the output current is internally limited to 300mA (TYP).

**Thermal Shutdown**

When the die temperature exceeds the threshold value of thermal shutdown, the SGM2068 will be in shutdown state and it will remain in this state until the die temperature decreases to +140°C.

**Power Dissipation ( $P_D$ )**

Power dissipation ( $P_D$ ) of the SGM2068 can be calculated by the equation  $P_D = (V_{IN} - V_{OUT}) \times I_{OUT}$ . The maximum allowable power dissipation ( $P_{D(MAX)}$ ) of the SGM2068 is affected by many factors, including the difference between junction temperature and ambient temperature ( $T_{J(MAX)} - T_A$ ), package thermal resistance from the junction to the ambient environment ( $\theta_{JA}$ ), the rate of ambient airflow and PCB layout.  $P_{D(MAX)}$  can be approximated by the following equation:

$$P_{D(MAX)} = (T_{J(MAX)} - T_A) / \theta_{JA} \quad (2)$$

**REVISION HISTORY**

NOTE: Page numbers for previous revisions may differ from page numbers in the current version.

<b>OCTOBER 2025 – REV.A.2 to REV.A.3</b>	<b>Page</b>
Updated Absolute Maximum Ratings section.....	3
Updated Functional Block Diagrams section.....	5
Updated Electrical Characteristics section.....	6
Updated Application Information section.....	13, 14

<b>NOVEMBER 2024 – REV.A.1 to REV.A.2</b>	<b>Page</b>
Added SGM2068-1.5XN5G/TR and SGM2068-1.5XTDI6G/TR versions.....	2

<b>MAY 2024 – REV.A to REV.A.1</b>	<b>Page</b>
Updated Electrical Characteristics section.....	6

  

<b>Changes from Original (DECEMBER 2023) to REV.A</b>	<b>Page</b>
Changed from product preview to production data.....	All

# PACKAGE INFORMATION

## PACKAGE OUTLINE DIMENSIONS

### SOT-23-5

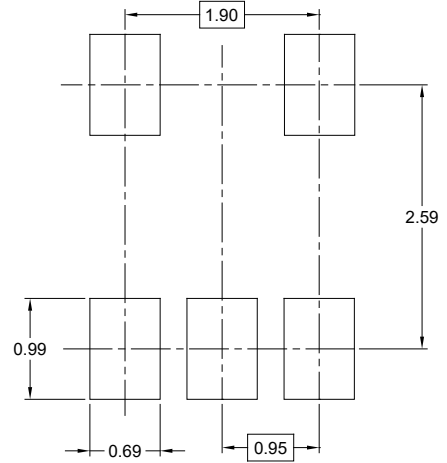
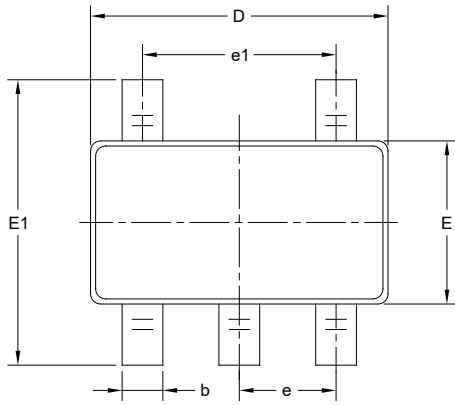

RECOMMENDED LAND PATTERN (Unit: mm)

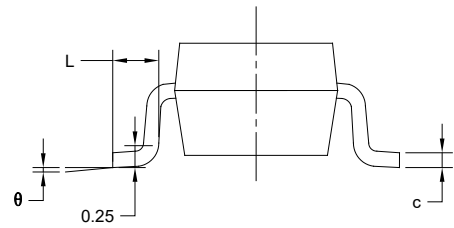
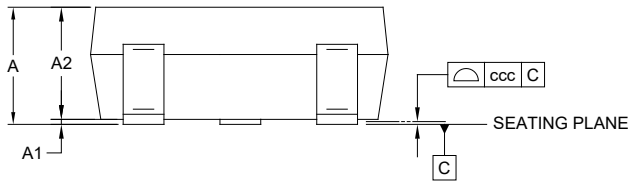

Symbol	Dimensions In Millimeters		
	MIN	NOM	MAX
A	-	-	1.450
A1	0.000	-	0.150
A2	0.900	-	1.300
b	0.300	-	0.500
c	0.080	-	0.220
D	2.750	-	3.050
E	1.450	-	1.750
E1	2.600	-	3.000
e	0.950 BSC		
e1	1.900 BSC		
L	0.300	-	0.600
$\theta$	0°	-	8°
ccc	0.100		

NOTES:

1. This drawing is subject to change without notice.
2. The dimensions do not include mold flashes, protrusions or gate burrs.
3. Reference JEDEC MO-178.

PACKAGE OUTLINE DIMENSIONS

TDFN-2x2-6AL

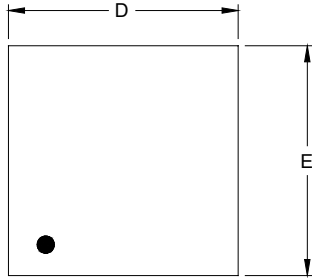

TOP VIEW

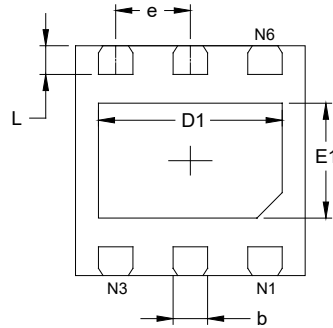

BOTTOM VIEW

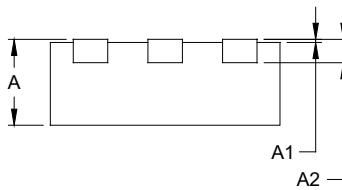

SIDE VIEW

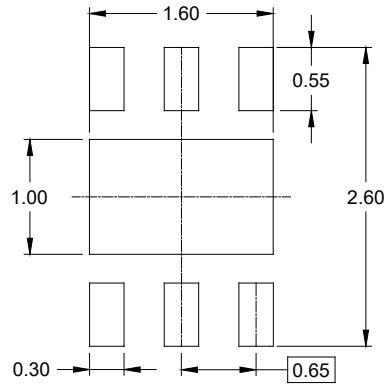

RECOMMENDED LAND PATTERN (Unit: mm)

Symbol	Dimensions In Millimeters		Dimensions In Inches	
	MIN	MAX	MIN	MAX
A	0.700	0.800	0.028	0.031
A1	0.000	0.050	0.000	0.002
A2	0.203 REF		0.008 REF	
D	1.900	2.100	0.075	0.083
D1	1.500	1.700	0.059	0.067
E	1.900	2.100	0.075	0.083
E1	0.900	1.100	0.035	0.043
b	0.250	0.350	0.010	0.014
e	0.650 BSC		0.026 BSC	
L	0.174	0.326	0.007	0.013

NOTE: This drawing is subject to change without notice.

TAPE AND REEL INFORMATION

REEL DIMENSIONS

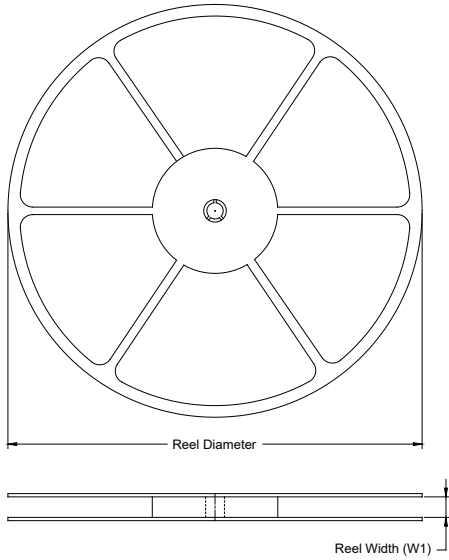

TAPE DIMENSIONS

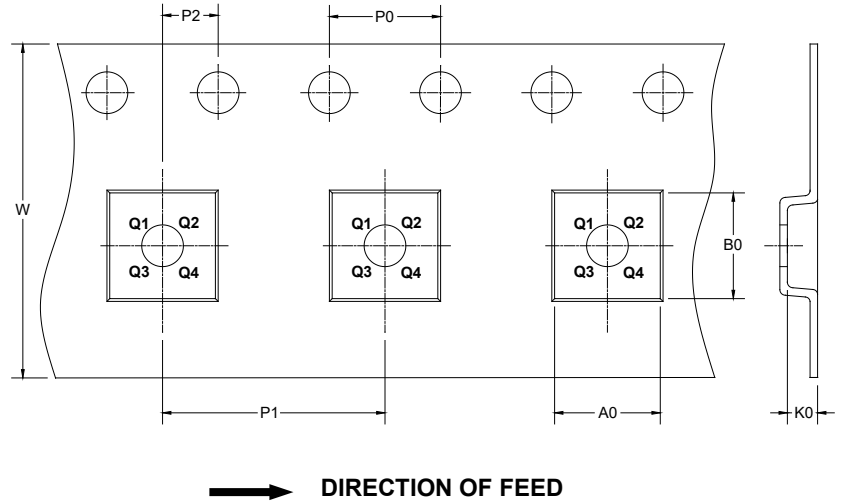

NOTE: The picture is only for reference. Please make the object as the standard.

KEY PARAMETER LIST OF TAPE AND REEL

Package Type	Reel Diameter	Reel Width W1 (mm)	A0 (mm)	B0 (mm)	K0 (mm)	P0 (mm)	P1 (mm)	P2 (mm)	W (mm)	Pin1 Quadrant
SOT-23-5	7"	9.5	3.20	3.20	1.40	4.0	4.0	2.0	8.0	Q3
TDFN-2×2-6AL	7"	9.5	2.30	2.30	1.10	4.0	4.0	2.0	8.0	Q2

DD0001

# PACKAGE INFORMATION

## CARTON BOX DIMENSIONS

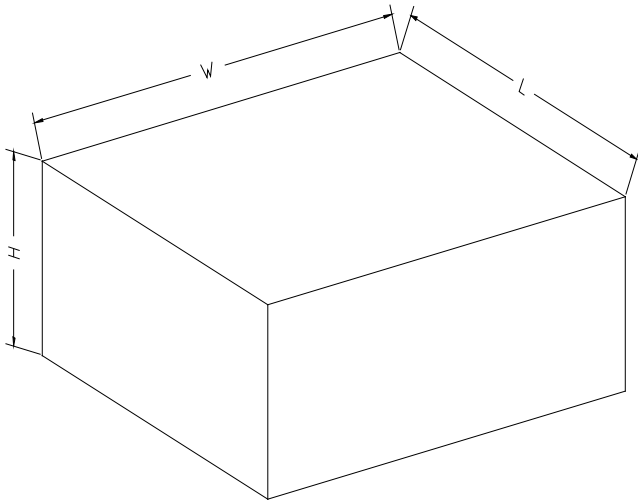

NOTE: The picture is only for reference. Please make the object as the standard.

## KEY PARAMETER LIST OF CARTON BOX

Reel Type	Length (mm)	Width (mm)	Height (mm)	Pizza/Carton
7" (Option)	368	227	224	8
7"	442	410	224	18

D00002