

GENERAL DESCRIPTION

The SGM2820 is a high efficiency, low EMI, filterless, Class-D audio amplifier with auto-recovering short-circuit protection. It operates from 2.5V to 5.5V supply voltage. When powered with 5V supply voltage, the SGM2820 is capable of delivering 3W into a 4Ω load or 1.7W into an 8Ω load, with 10% THD+N.

As a Class-D audio amplifier, the SGM2820 features 88% efficiency and 70dB PSRR at 217Hz which make the device ideal for battery-powered high-quality audio applications.

A key benefit of the SGM2820 over typical Class-D audio power amplifiers is that it generates much less EMI emissions, thus greatly simplifying the system design for portable applications. The device includes the over-current and short-circuit protections with auto-recovery, which ensures the device can be operated safely and reliably without system interaction.

APPLICATIONS

- Mobile Phones
- Portable Navigation Devices
- Multimedia Internet Devices
- Portable Speakers

TYPICAL APPLICATION

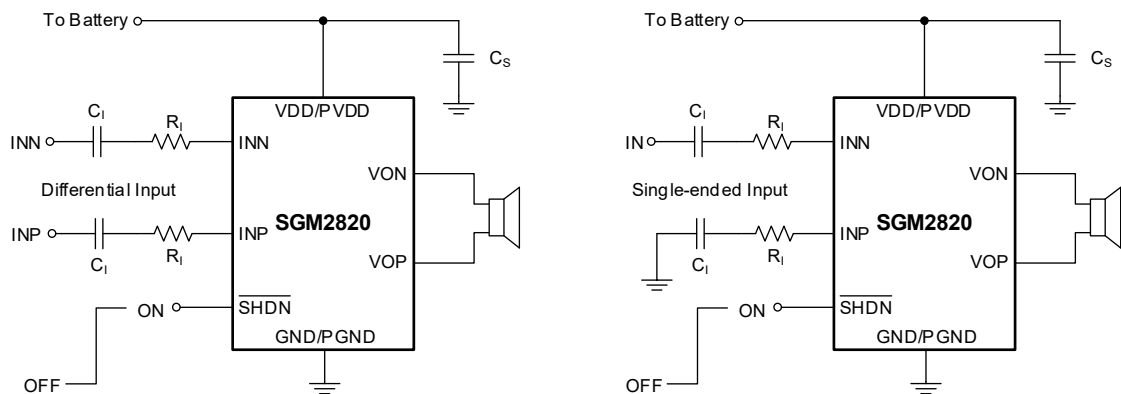

Figure 1. Typical Application Circuits

FEATURES

- Filterless Class-D Operation
- High Efficiency up to 88%
- Maximum Output Power at 5V Supply
 - ◆ 3.0W (4Ω Load, THD+N = 10%)
 - ◆ 1.7W (8Ω Load, THD+N = 10%)
- Maximum Output Power at 3.6V Supply
 - ◆ 1.5W (4Ω Load, THD+N = 10%)
 - ◆ 0.88W (8Ω Load, THD+N = 10%)
- Low THD+N: 0.03% ($V_{DD} = 3.6V$, $f = 1kHz$, $R_L = 8\Omega$, $P_O = 0.5W$)
- Low Quiescent Current: 2.1mA at $V_{DD} = 3.6V$
- Maximum Gain: 24dB (15.9V/V)
- Low Shutdown Current: 0.1μA
- High PSRR: 70dB at 217Hz
- No Bypass Capacitor Required for the Common-Mode Bias
- Under-Voltage Lockout
- Auto-Recovering Over-Current and Short-Circuit Protections
- Thermal Overload Protection
- Low EMI Design
- Available in Green UTQFN-1.5×1.5-9L and MSOP-8 Packages

3W Low EMI Class-D Audio Power Amplifier with Auto-Recovering Short-Circuit Protection

SGM2820

PACKAGE/ORDERING INFORMATION

MODEL	PACKAGE DESCRIPTION	SPECIFIED TEMPERATURE RANGE	ORDERING NUMBER	PACKAGE MARKING	PACKING OPTION
SGM2820	UTQFN-1.5×1.5-9L	-40°C to +85°C	SGM2820YUSN9G/TR	09R XXX	Tape and Reel, 3000
	MSOP-8	-40°C to +85°C	SGM2820YMS8G/TR	SGM2820 YMS8 XXXXX	Tape and Reel, 4000

MARKING INFORMATION

NOTE: XXX = Date Code and Trace Code. XXXXX = Date Code, Trace Code and Vendor Code.

UTQFN-1.5×1.5-9L

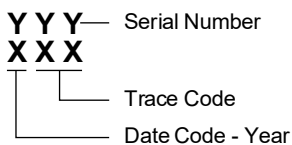

MSOP-8

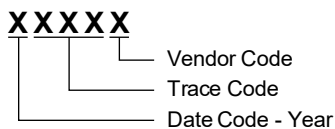

Green (RoHS & HSF): SG Micro Corp defines "Green" to mean Pb-Free (RoHS compatible) and free of halogen substances. If you have additional comments or questions, please contact your SGMICRO representative directly.

ABSOLUTE MAXIMUM RATINGS

- Supply Voltage..... -0.3V to 6V
- All Other Pins.....-0.3V to $V_{DD} + 0.3V$
- Package Thermal Resistance
- UTQFN-1.5×1.5-9L, θ_{JA} 219°C/W
- MSOP-8, θ_{JA} 157°C/W
- Junction Temperature..... +150°C
- Storage Temperature Range -65°C to +150°C
- Lead Temperature (Soldering, 10s).....+260°C
- ESD Susceptibility
- HBM..... 5000V
- CDM 1000V

RECOMMENDED OPERATING CONDITIONS

- Supply Voltage, V_{DD}2.5V to 5.5V
- Minimum Load Resistance, R_{LOAD} , $V_{DD} < 4.6V$ 3.2Ω
- Minimum Load Resistance, R_{LOAD} , $V_{DD} \geq 4.6V$ 3.6Ω
- Operating Ambient Temperature, T_A -40°C to +85°C

OVERSTRESS CAUTION

Stresses beyond those listed in Absolute Maximum Ratings may cause permanent damage to the device. Exposure to absolute maximum rating conditions for extended periods may affect reliability. Functional operation of the device at any conditions beyond those indicated in the Recommended Operating Conditions section is not implied.

ESD SENSITIVITY CAUTION

This integrated circuit can be damaged if ESD protections are not considered carefully. SGMICRO recommends that all integrated circuits be handled with appropriate precautions. Failure to observe proper handling and installation procedures can cause damage. ESD damage can range from subtle performance degradation to complete device failure. Precision integrated circuits may be more susceptible to damage because even small parametric changes could cause the device not to meet the published specifications.

DISCLAIMER

SG Micro Corp reserves the right to make any change in circuit design, or specifications without prior notice.

PIN CONFIGURATIONS

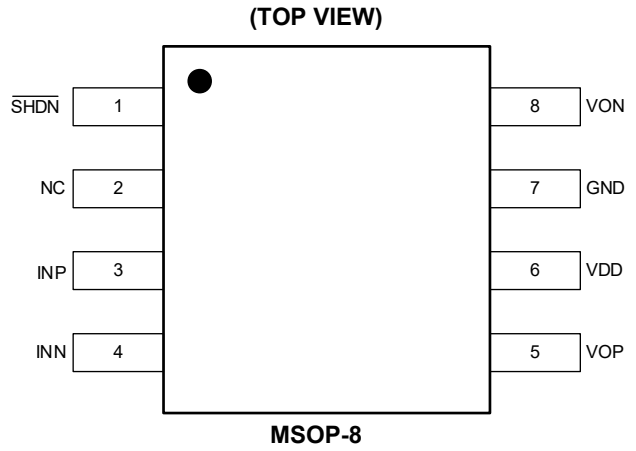
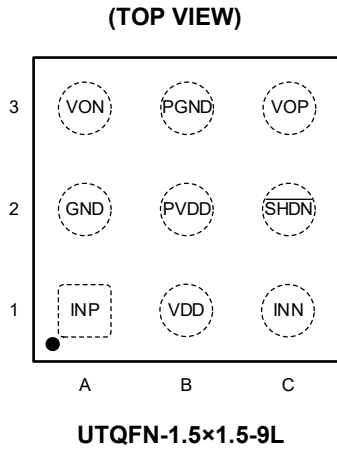

PIN DESCRIPTION

PIN		NAME	DESCRIPTION
MSOP-8	UTQFN-1.5×1.5-9L		
1	C2	$\overline{\text{SHDN}}$	Active Low Shutdown Control.
2	—	NC	No Internal Connection.
3	A1	INP	Positive Audio Input Terminal.
4	C1	INN	Negative Audio Input Terminal.
5	C3	VOP	Positive BTL Audio Output Terminal.
6	B1	VDD	Power Supply.
—	B2	PVDD	Power Supply for the Output Stage. For MSOP-8 package, it is internally shorted to VDD. For UTQFN-1.5×1.5-9L package, it must be externally shorted to VDD on the system board.
7	A2	GND	Ground.
—	B3	PGND	Power Ground for the Output Stage. For MSOP-8 package, it is internally shorted to GND. For UTQFN-1.5×1.5-9L package, it must be externally shorted to GND on the system board.
8	A3	VON	Negative BTL Audio Output Terminal.

IMPORTANT APPLICATION NOTES

1. As a Class-D power audio amplifier, the SGM2820 requires adequate power supply decoupling to ensure its optimum performance such as output power, efficiency, and THD+N. Place decoupling capacitors as close to the VDD pin as possible. For the best power supply coupling, it is strongly recommended to add a 100µF or greater capacitor placed near the audio power amplifier.
2. It is recommended to employ a ground plane for SGM2820 on the system board.
3. Use a simple ferrite bead filter for further EMI suppression. Choose a ferrite bead with a rated current which is no less than 2A or greater for applications with

a load resistance less than 6Ω. Also, place the respective ferrite bead filters as close to the output pins, VOP and VON, as possible.

4. For applications where the power supply is rated more than 4.6V or the load resistance less than 6Ω, it is strongly recommended to add a simple snubber circuit (as shown in Figure 5) between the two output pins, VOP and VON, to prevent the device from accelerated deterioration or abrupt destruction due to excessive inductive flybacks that are induced on fast output switching or by an over-current or short-circuit condition.

TEST SETUP FOR PERFORMANCE TESTING

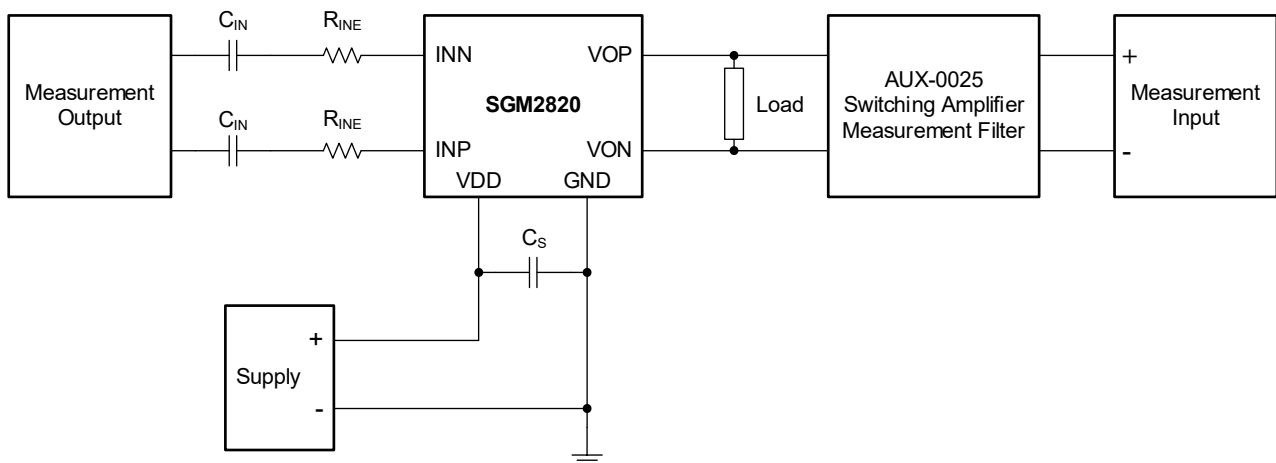

NOTE:

1. A 33µH inductor is placed in series with the load resistor to emulate a small speaker for efficiency measurements.

Figure 2. Test Block Diagram

SGM2820

3W Low EMI Class-D Audio Power Amplifier with Auto-Recovering Short-Circuit Protection

ELECTRICAL CHARACTERISTICS

($T_A = -40^{\circ}\text{C}$ to $+85^{\circ}\text{C}$, $V_{DD} = 2.5\text{V}$ to 5.5V , $f = 1\text{kHz}$, $R_L = 8\Omega$, Gain = 15.9V/V , $R_{INE} = 0\text{k}\Omega$ and $C_{IN} = 0.1\mu\text{F}$, all typical values are measured at $T_A = +25^{\circ}\text{C}$, unless otherwise noted.)

PARAMETER	SYMBOL	CONDITIONS	MIN	TYP	MAX	UNITS
Supply Voltage	V_{DD}		2.5		5.5	V
Power Up Threshold Voltage	V_{UVLU}	V_{DD} from Low to High		2.3	2.5	V
Power Down Threshold Voltage	V_{UVLD}	V_{DD} from High to Low	1.8	2.0		V
Quiescent Current	I_{DD}	$V_{DD} = 2.5\text{V}$, No Load, Inputs AC-Grounded		1.7	3.2	mA
		$V_{DD} = 3.6\text{V}$, No Load, Inputs AC-Grounded		2.1	3.3	
		$V_{DD} = 5.5\text{V}$, No Load, Inputs AC-Grounded		2.6	3.4	
Shutdown Current	I_{SD}	$\overline{\text{SHDN}}$ Low		0.1	2	μA
$\overline{\text{SHDN}}$ Input High	V_{SDIH}		1.35			V
$\overline{\text{SHDN}}$ Input Low	V_{SDIL}				0.4	V
Maximum Output Power $V_{DD} = 5\text{V}$, Load = 8Ω	P_O	THD+N = 10%		1.7		W
		THD+N = 1%		1.4		
Maximum Output Power $V_{DD} = 3.6\text{V}$, Load = 8Ω	P_O	THD+N = 10%		0.88		W
		THD+N = 1%		0.7		
Maximum Output Power $V_{DD} = 5\text{V}$, Load = 4Ω	P_O	THD+N = 10%		3.0		W
		THD+N = 1%		2.4		
Maximum Output Power $V_{DD} = 3.6\text{V}$, Load = 4Ω	P_O	THD+N = 10%		1.5		W
		THD+N = 1%		1.2		
Gain	A_V	No Load, $V_{IN} = 0.1V_{RMS}$	14.5	15.9	17	V/V
Internal Input Resistance	R_{INI}	@INP, INN		18.8		$\text{k}\Omega$
Output Resistance in Shutdown Mode	R_O	$V_{DD} = 3.6\text{V}$, $\overline{\text{SHDN}}$ Low		2.2		$\text{k}\Omega$
$\overline{\text{SHDN}}$ Input Resistance	R_{SHDN}	$V_{DD} = 3.6\text{V}$		300		$\text{k}\Omega$
VREF Voltage	V_{REF}	$V_{DD} = 3.6\text{V}$		$V_{DD}/2$		V
Total Harmonic Distortion + Noise Load = 8Ω	THD+N	$V_{DD} = 3.6\text{V}$, $P_O = 0.5\text{W}$		0.03		%
		$V_{DD} = 5\text{V}$, $P_O = 1\text{W}$		0.03		
Total Harmonic Distortion + Noise Load = 4Ω	THD+N	$V_{DD} = 3.6\text{V}$, $P_O = 1\text{W}$		0.05		%
		$V_{DD} = 5\text{V}$, $P_O = 2\text{W}$		0.05		
Output Voltage Noise	V_N	Bandwidth = 20Hz ~ 20kHz, Inputs AC-Grounded, $V_{DD} = 3.6\text{V}$		70		μV_{RMS}
Output Offset Voltage	V_{OS}	Inputs AC-Grounded, Output measured differentially		± 10	± 55	mV
Efficiency	η	$V_{DD} = 5\text{V}$, $R_L = 8\Omega + 33\mu\text{H}$, $P_O = 1\text{W}$		88		%
Power Supply Rejection Ratio	PSRR	$V_{DD} = 3.6\text{V}$, $f = 217\text{Hz}$		70		dB
Common Mode Rejection Ratio	CMRR	$V_{DD} = 3.6\text{V}$, $f = 1\text{kHz}$, $V_{IN} = 0.1V_{RMS}$		70		dB
Startup Time	t_{STUP}	$V_{DD} = 3.6\text{V}$		35		ms
PWM Carrier Frequency	f_{PWM}	Inputs AC-Grounded		400		kHz
PWM Frequency Jittering Range	f_{JITTER}	Inputs AC-Grounded		± 12		kHz
Over-Current Threshold	I_{LIMIT}	$V_{DD} = 5\text{V}$		2.0		A
Over-Temperature Threshold	T_{OTP}			160		$^{\circ}\text{C}$
Over-Temperature Hysteresis	T_{HYS}			30		$^{\circ}\text{C}$

SGM2820 3W Low EMI Class-D Audio Power Amplifier with Auto-Recovering Short-Circuit Protection

FUNCTIONAL BLOCK DIAGRAM

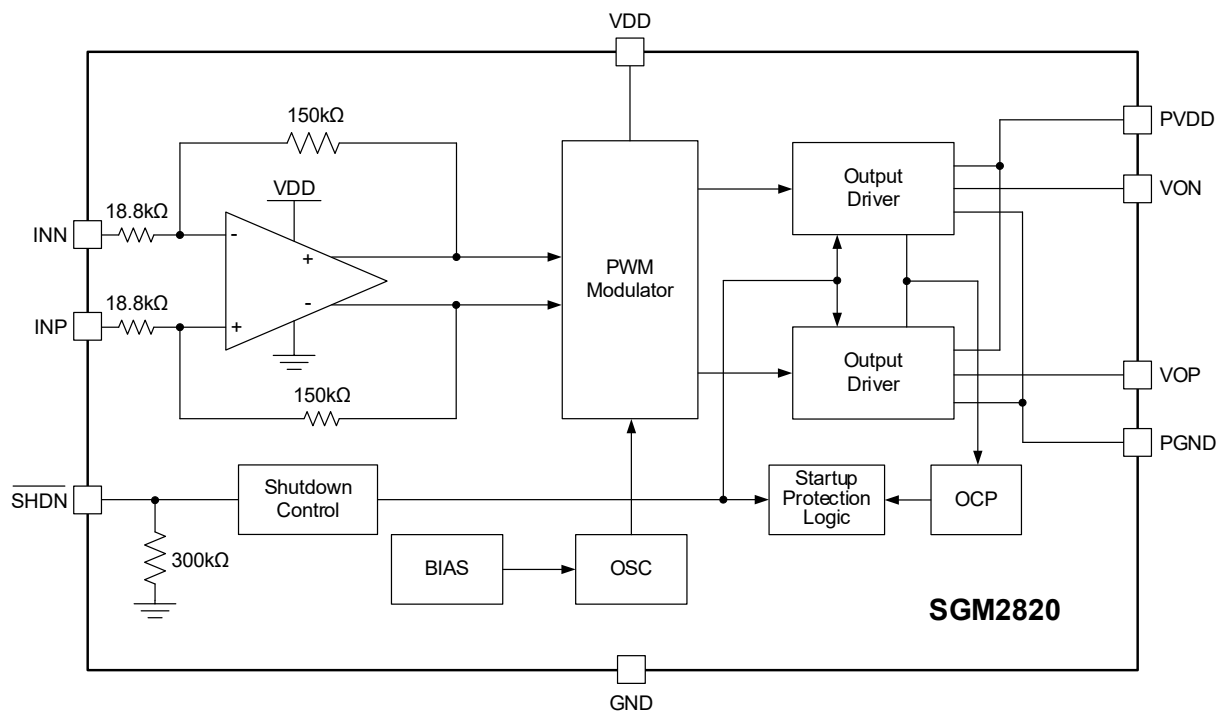
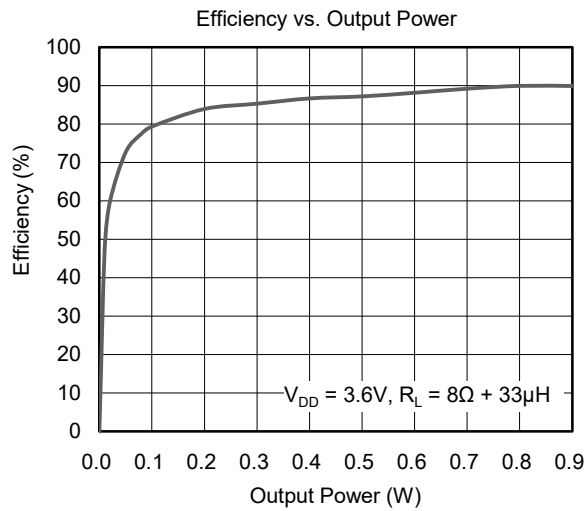
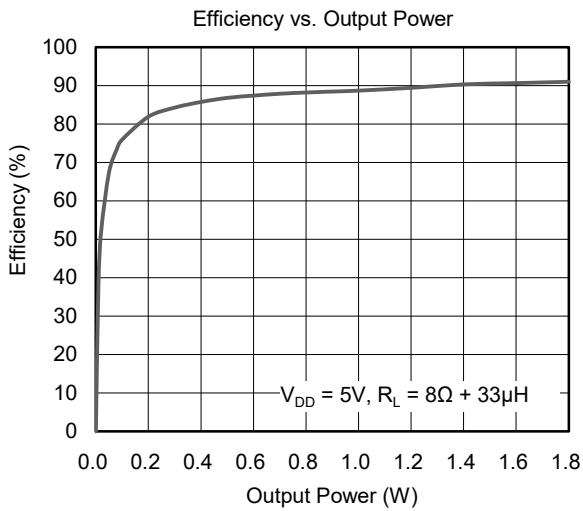
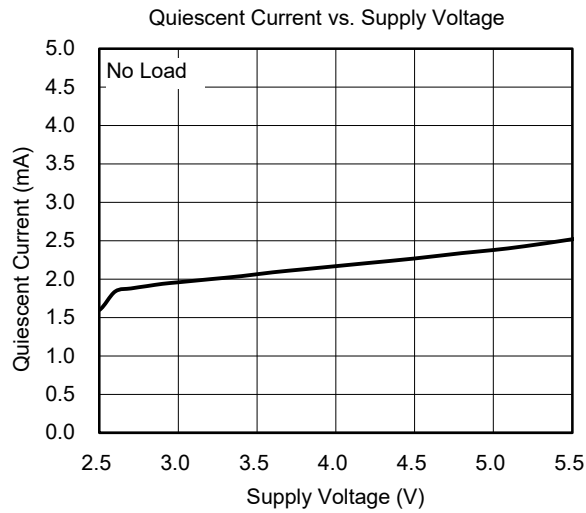
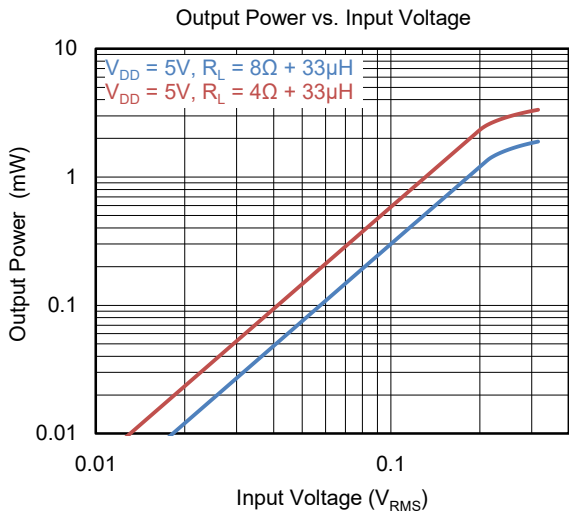
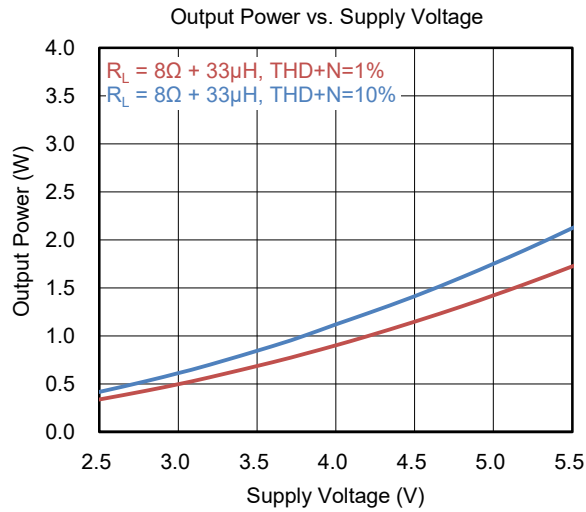
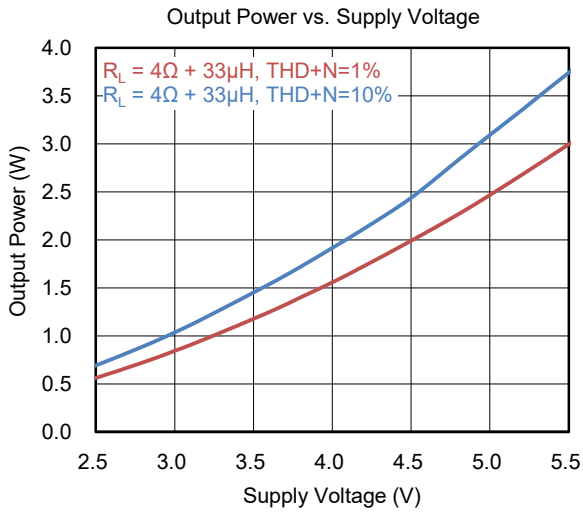

Figure 3. Simplified Function Block Diagram of SGM2820

SGM2820 3W Low EMI Class-D Audio Power Amplifier with Auto-Recovering Short-Circuit Protection

TYPICAL PERFORMANCE CHARACTERISTICS

MSOP-8 package, $T_A = +25^\circ\text{C}$, $V_{DD} = 3.6\text{V}$, $f = 1\text{kHz}$, Gain = 15.9V/V, $R_{INE} = 0\Omega$ and $C_{IN} = 0.1\mu\text{F}$, unless otherwise noted.



SGM2820 3W Low EMI Class-D Audio Power Amplifier with Auto-Recovering Short-Circuit Protection

TYPICAL PERFORMANCE CHARACTERISTICS (continued)

MSOP-8 package, $T_A = +25^\circ\text{C}$, $V_{DD} = 3.6\text{V}$, $f = 1\text{kHz}$, Gain = 15.9V/V, $R_{INE} = 0\Omega$ and $C_{IN} = 0.1\mu\text{F}$, unless otherwise noted.

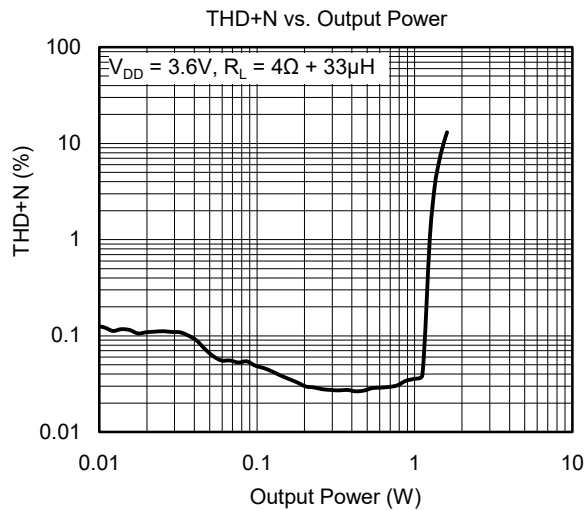
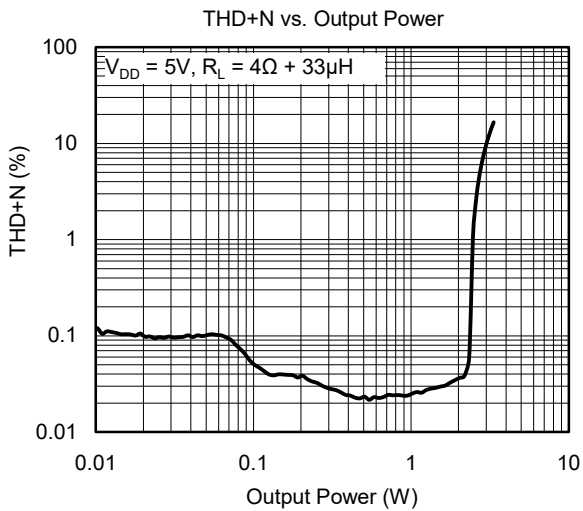
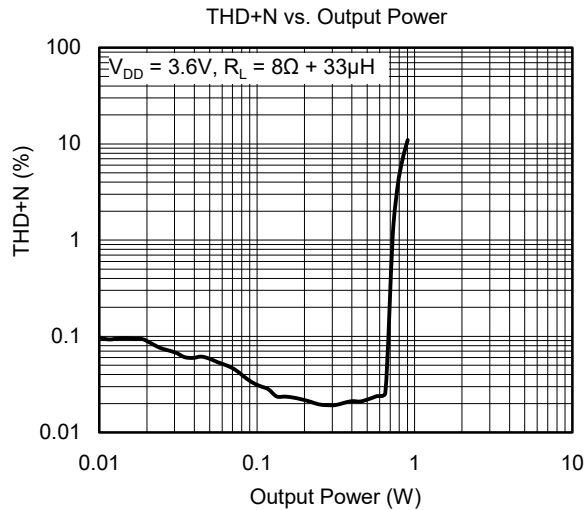
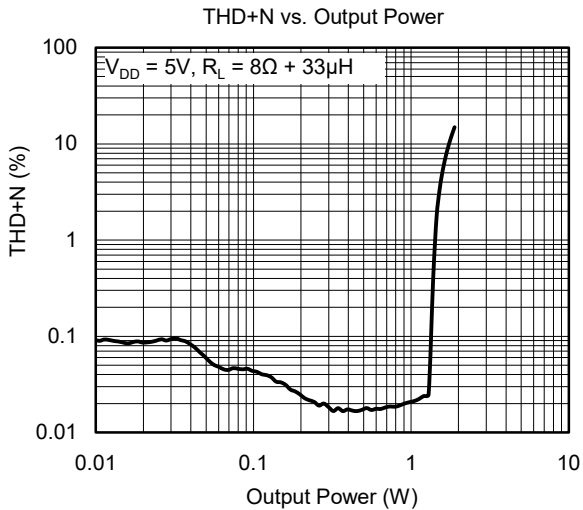
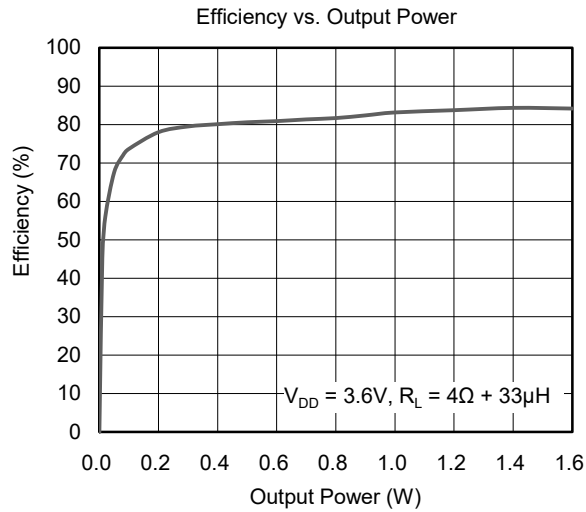
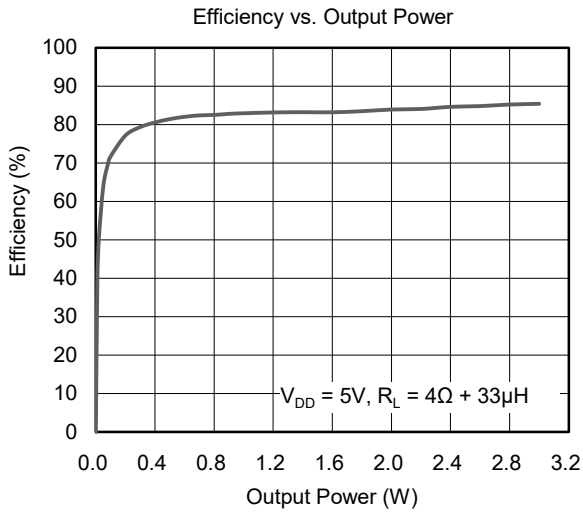

SGM2820 3W Low EMI Class-D Audio Power Amplifier with Auto-Recovering Short-Circuit Protection

TYPICAL PERFORMANCE CHARACTERISTICS (continued)

MSOP-8 package, $T_A = +25^\circ\text{C}$, $V_{DD} = 3.6\text{V}$, $f = 1\text{kHz}$, Gain = 15.9V/V, $R_{INE} = 0\Omega$ and $C_{IN} = 0.1\mu\text{F}$, unless otherwise noted.

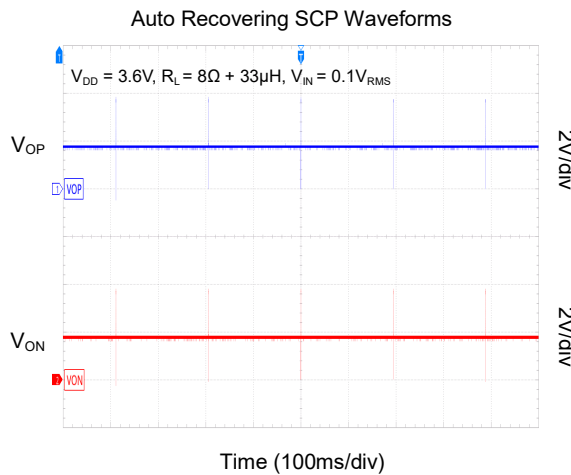
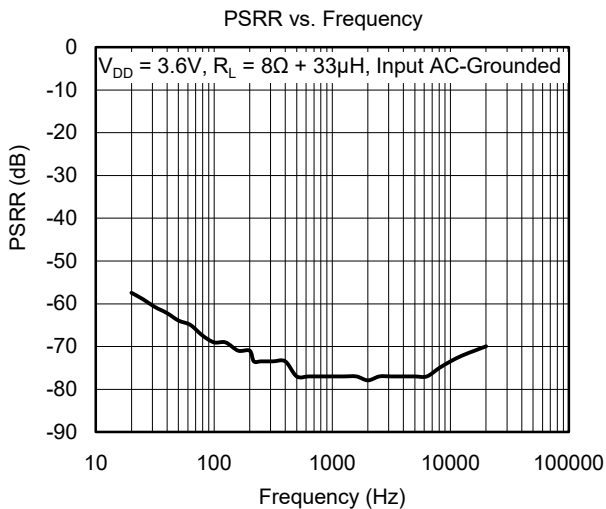
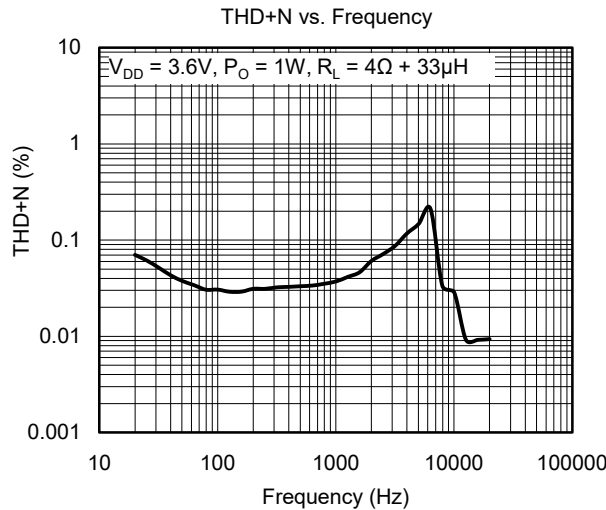
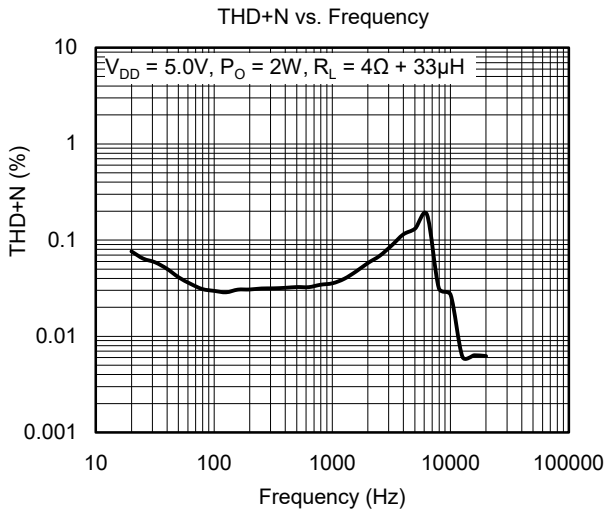
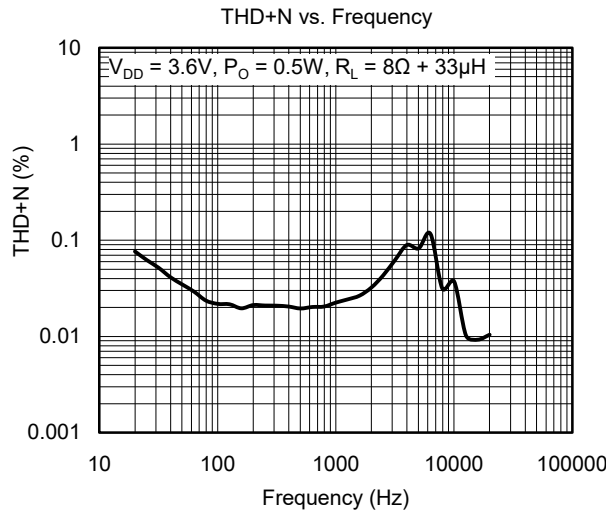
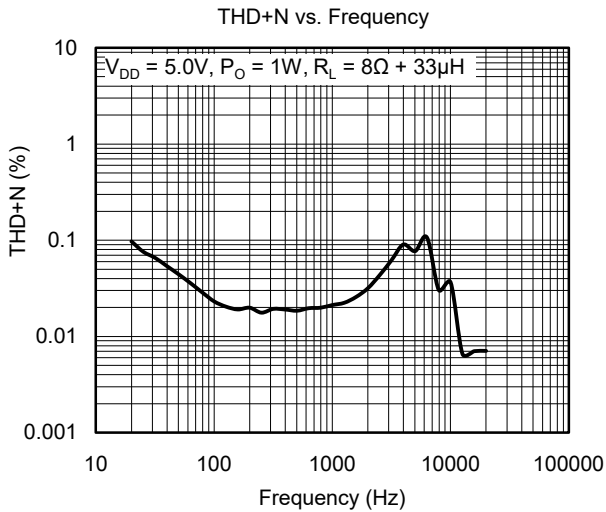

APPLICATION INFORMATION

The SGM2820 is a high efficiency, low EMI, filterless, Class-D audio power amplifier with auto-recovering short-circuit protection. The SGM2820 operates from 2.5V to 5.5V supply. When powered with 5V supply voltage, it is capable of delivering up to 3W into a 4Ω load or 1.7W into an 8Ω load, with 10% THD+N.

As a Class-D power audio amplifier, the SGM2820 features 88% high efficiency and 70dB PSRR at 217Hz which make the device ideal for battery-supplied, high-quality audio applications. A key benefit of the SGM2820 over typical Class-D audio power amplifiers is that it generates much less EMI emissions, thus greatly simplifying the system design for portable applications. The device includes the circuitry can minimize turn-on and turn-off transients (also known as pops-and-clicks) and auto-recovering over-current protection (OCP) and short-circuit protection (SCP).

Furthermore, the SGM2820 includes under-voltage lockout to ensure proper operation when the device is first powered up, and thermal-overload protection to safeguard the die temperature during operation.

Fully Differential Amplifier

The SGM2820 is configured in a fully differential topology. The fully differential topology ensures that the amplifier outputs a differential voltage on the output that is equal to the differential input times the gain. The common-mode feedback ensures that the common-mode voltage at the output is biased around $V_{DD}/2$ regardless of the common-mode voltage at the input. Although the fully differential topology of the SGM2820 can still be used with a single-ended input, it is highly recommended that the SGM2820 be used with differential inputs in a noisy environment, like a wireless handset, to ensure maximum noise rejection.

Filterless Design

Traditional Class-D amplifiers require an output filter. The filter adds cost and the size of the system board. Furthermore, it degrades the performance of power efficiency and THD+N. The SGM2820's filterless modulation scheme does not require an output filter. Because the switching frequency of the SGM2820 is well beyond the bandwidth of most speakers, voice coil movement due to the switching frequency is very small.

Use a speaker with a series inductance larger than 10μH. An 8Ω speaker typically exhibits a series inductance in the range from 20μH to 100μH.

However, LC filter is required when the trace between the SGM2820 and the speaker exceeds 100mm. Long trace acts like tiny antenna and generates EMI emissions which may result in FCC and CE certification failures.

Low EMI Design

Traditional Class-D amplifiers require the use of external LC filters or shielding to minimize EMI emissions. The SGM2820 employs a proprietary design of the amplifier output stage in conjunction with frequency jittering technique to minimize EMI emissions while maintaining high efficiency.

How to Reduce EMI

The SGM2820 does not require an LC output filter for short connections from the amplifier to the speaker. However, additional EMI suppressions can be made by use of a ferrite bead in conjunction with a capacitor, as shown in Figure 4. Choose a ferrite bead with low DC resistance (DCR) and high impedance (100Ω ~ 330Ω) at high frequencies (> 100MHz). The current flowing through the ferrite bead must be also taken into consideration. The effectiveness of ferrites can be greatly aggravated at much lower than the rated current values. Choose a ferrite bead with a rated current value no less than 2A. The capacitor value varies based on the chosen ferrite bead and the actual speaker lead length. Choose a capacitor less than 1nF based on EMI performance.

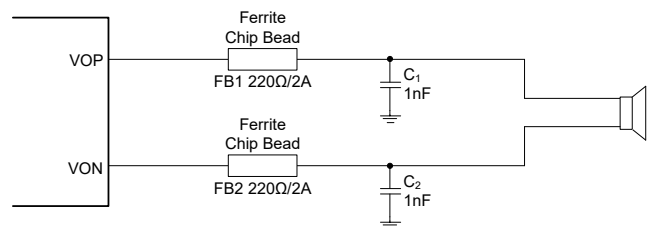

Figure 4. Ferrite Bead Filter to Reduce EMI

APPLICATION INFORMATION (continued)

RC Snubber Circuit

For applications where the power supply is rated more than 4.6V or the load resistance less than 6Ω, it may become necessary to add an RC snubber circuit between the two output pins, VOP and VON, for robustness and reliability. Figure 5 shows a simple RC snubber circuit, which can be used to prevent the device from accelerated deterioration or abrupt destruction due to excessive inductive flybacks that are induced on fast output switching or by an over-current or short-circuit condition.

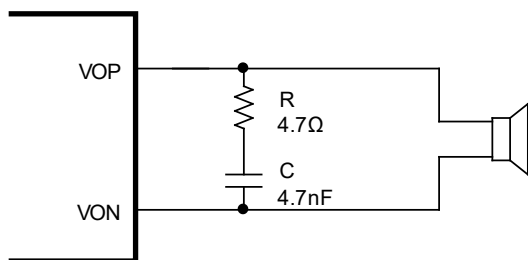

Figure 5. RC Snubber Circuit

Shutdown and Startup

The SGM2820 employs the pin to minimize power consumption while it is not in use. When the pin is pulled to low, the SGM2820 is forced into shutdown mode, where all the analog circuitry is de-biased and the supply current is reduced to 0.1μA (TYP), and the differential outputs are individually pulled to ground through 2.2kΩ internal resistors. When the pin is asserted to high, the device exits out of shutdown mode and resumes normal operation after the startup time (t_{STUP}) of 35ms (TYP).

Under-Voltage Lockout (UVLO)

The SGM2820 incorporates circuitry designed to detect a low supply voltage. When the supply voltage drops below 2.0V (TYP), the SGM2820 goes into shutdown mode. The device will emerge out of the shutdown mode and resume its normal operation only when the supply voltage is restored to above 2.3V (TYP) and the SHDN pin is pulled high.

Auto-Recovering Over-Current Protection (OCP) & Short-Circuit Protection (SCP)

Once an over-current or a short-circuit condition at the differential outputs is detected, either to the power supply or to ground or to each other, the SGM2820 goes into shutdown mode. During shutdown, the SGM2820 activates auto-recovering process whose aim is to return the device to normal operation once the fault condition is removed. This process repeatedly examines if the fault condition persists, and returns the device to normal operation immediately after the fault condition is removed. This feature helps protect the device from large currents and maintain long-term reliability while removing the need for external system interaction to resume normal operation.

Over-Temperature Shutdown (OTSD)

The thermal-overload protection on the SGM2820 prevents the device from being damaged when the die temperature exceeds +160°C. Once the die temperature exceeds the prescribed value, the device will be forced into shutdown mode and the outputs are disabled. Note that this is not a latched fault. Instead, the thermal fault will be cleared once the temperature of the die is lowered by 30°C. This large hysteresis will prevent it from generating motor boating sound and allow the device resume normal operation without the need for external system interaction.

Pop-and-Click Suppression

When asserting SHDN pin from low to high level, the SGM2820 features a 35ms startup turn-on time to suppress the click-pop noise. For the best power-off pop performance, the amplifier should be placed in shutdown mode before removing the power supply voltage.

APPLICATION INFORMATION (continued)**Input Resistors (R_{INE})**

The input resistors (R_{INE}) set the gain of the amplifier according to Equation 1.

$$\text{Gain} = \frac{2 \times 150}{R_{INE} + 18.8} \left(\frac{V}{V} \right) \quad (1)$$

In Equation 1, Gain is the desired voltage gain of the amplifier and R_{INE} is expressed in $k\Omega$. The matching of the input resistors is a crucial consideration for a fully differential amplifier. The balance of the differential outputs with respect to the common-mode voltage strongly depends on the matching of the input resistors. The CMRR, PSRR, and the cancellation of the even-order harmonics will be significantly degraded if the mismatch of the input resistors occurs. Therefore, it is recommended to use the resistors with 1% tolerance or better to keep the performance optimized. Note that the matching tolerance of the input resistors is much more important than the absolute tolerance. Place the input resistors as close to the SGM2820 as possible to minimize the noise injected onto the high-impedance input nodes.

Decoupling Capacitor (C_S)

The decoupling capacitor stabilizes the power supply voltage applied onto the SGM2820, thus improving its THD performance. It also prevents voltage ringing with a long lead. A capacitor of $1\mu\text{F}$ or greater with low equivalent-series-resistance (ESR) is required for decoupling and to be placed as close to the SGM2820 as possible to minimize the resistance and inductance of the traces between the device and the capacitor. To filter out lower-frequency noise, a capacitor of $10\mu\text{F}$ or greater should be placed close to the SGM2820.

Input Capacitors (C_{IN})

The input capacitors and input resistors determine the corner frequency of the high-pass filter. The corner frequency (f_c) is calculated with the Equation 2.

$$f_c = \frac{1}{2\pi \times (R_{INE} + 18.8) \times C_{IN}} \quad (2)$$

The corner frequency directly influences the low frequency signals and consequently determines output bass quality.

APPLICATION INFORMATION (continued)**PCB Layout**

As the output power increases, the interconnect resistance (PCB traces and wires) among the audio amplifier, load, and power supply creates a voltage drop. The voltage loss on the traces between the SGM2820 and the load results in lower output power and lower efficiency. The higher trace resistance between the supply and the SGM2820 has the same effect as a poorly regulated supply, increasing the voltage ripples on the supply line and also reducing the peak output power. The effect of the residual trace resistance will be intensified as the output current increases. To maintain the highest output voltage swing for a maximum output power, the PCB traces that connect the output pins to the load and the supply pins to the power supply should be as wide and short as possible to minimize trace resistance.

The use of power and ground planes will give the best THD+N performance. While reducing trace resistance, the use of power planes also creates parasitic capacitors that help filter the power supply line.

The inductive nature of the speakers can also result in overshoots on one or both edges, clamped by the parasitic diodes to ground and VDD in each case. From an EMI standpoint, this is the highly unfavorable waveform that will radiate or conduct to other components on the system board and cause interference. It is essential to keep the power and output traces short and well shielded if possible. Use of ground planes, beads, and micro-strip layout techniques are all useful in preventing unwanted interference.

As the distance from the SGM2820 to the speaker increases, the amount of EMI radiation will increase since the output wires or traces acting as antenna become more efficient with their lengths. What is acceptable EMI is highly application specific. Ferrite beads placed close to the SGM2820 may be needed to reduce EMI radiation. The value of the ferrite beads is also application specific.

TYPICAL APPLICATION CIRCUITS

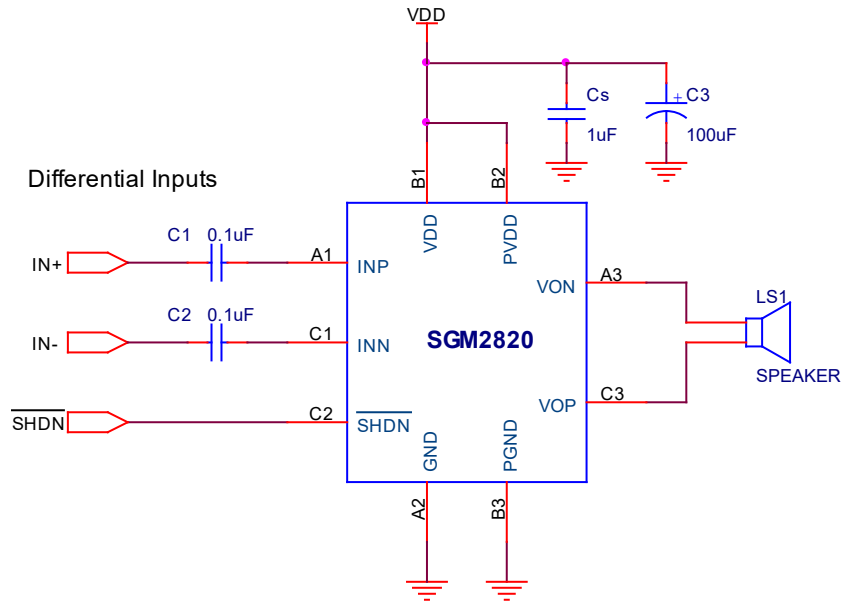

Figure 6. Differential Audio Input (UTQFN-1.5×1.5-9L Package for Mobile Phone Application)

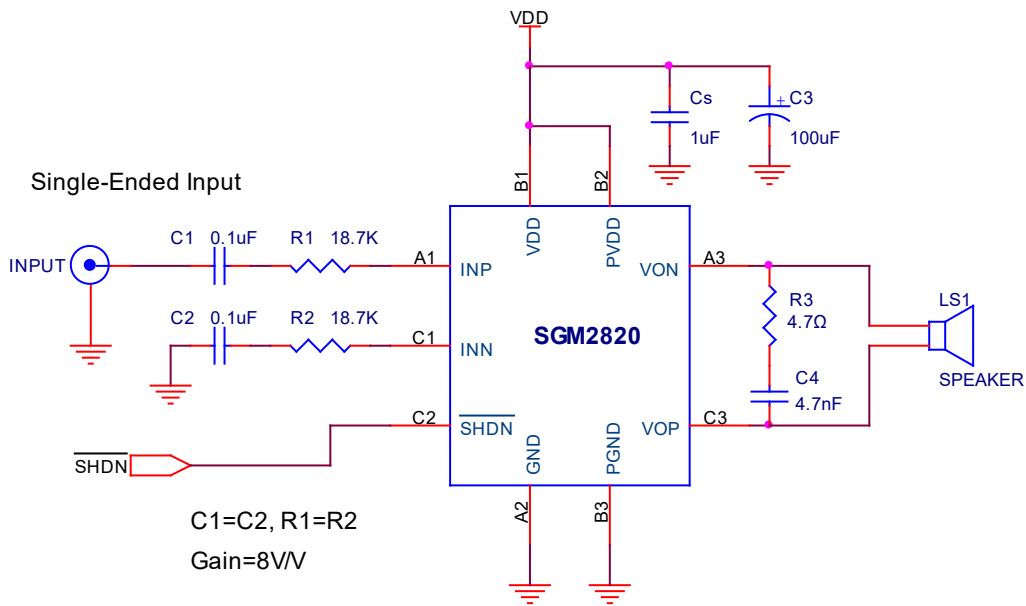

Figure 7. Single-Ended Audio Input Application (UTQFN-1.5×1.5-9L Package)

SGM2820 3W Low EMI Class-D Audio Power Amplifier with Auto-Recovering Short-Circuit Protection

TYPICAL APPLICATION CIRCUITS (continued)

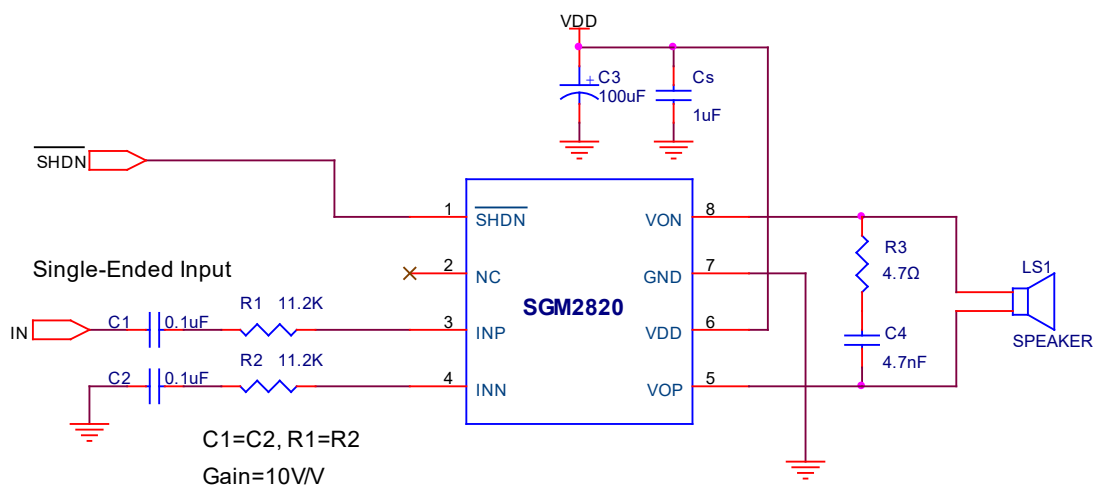

Figure 8. Single-Ended Audio Input Application (MSOP-8 Package)

REVISION HISTORY

NOTE: Page numbers for previous revisions may differ from page numbers in the current version.

OCTOBER 2023 – REV.A to REV.A.1	Page
Updated Figure 1. Typical Application Circuits	1
Updated the Pop-and-Click Suppression section	11

Changes from Original (AUGUST 2023) to REV.A	Page
Changed from product preview to production data.....	All

PACKAGE OUTLINE DIMENSIONS

UTQFN-1.5×1.5-9L

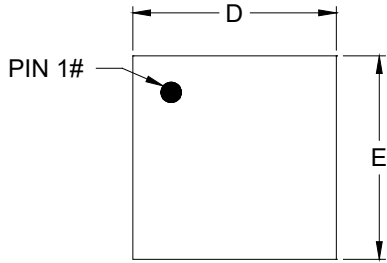

TOP VIEW

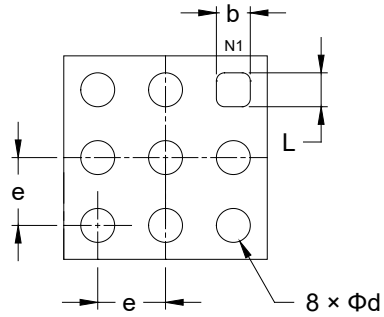

BOTTOM VIEW

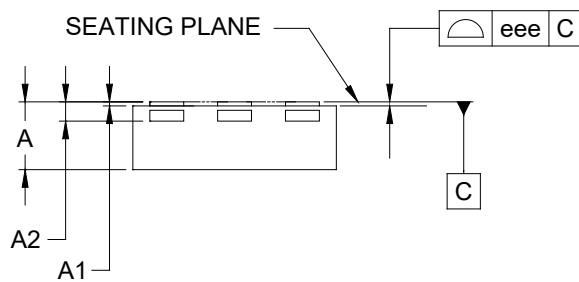

SIDE VIEW

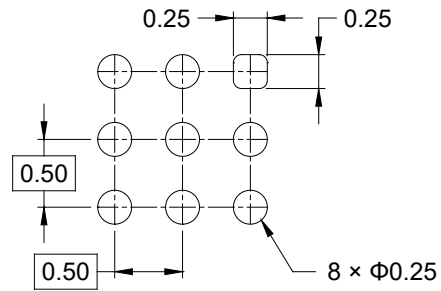

RECOMMENDED LAND PATTERN (Unit: mm)

Symbol	Dimensions In Millimeters		
	MIN	MOD	MAX
A	0.450	-	0.550
A1	0.000	-	0.050
A2	0.152 REF		
b	0.174	-	0.326
D	1.400	-	1.600
E	1.400	-	1.600
d	0.174	-	0.326
e	0.500 BSC		
L	0.174	-	0.326
eee	0.050		

NOTE: This drawing is subject to change without notice.

PACKAGE OUTLINE DIMENSIONS

MSOP-8

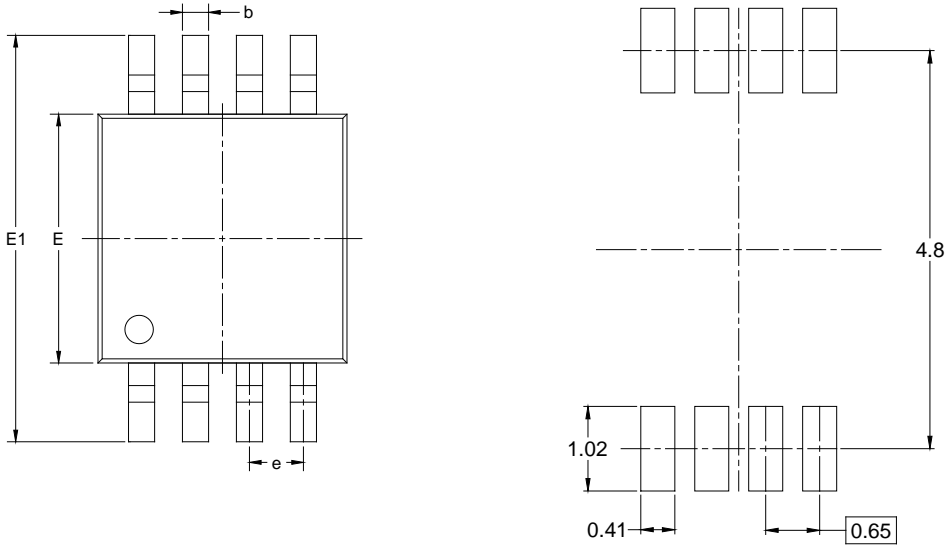

RECOMMENDED LAND PATTERN (Unit: mm)

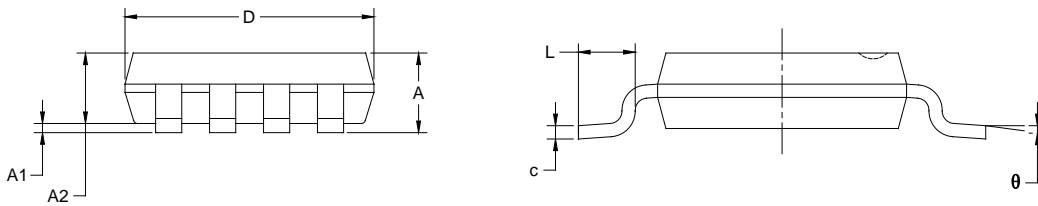

Symbol	Dimensions In Millimeters		Dimensions In Inches	
	MIN	MAX	MIN	MAX
A	0.820	1.100	0.032	0.043
A1	0.020	0.150	0.001	0.006
A2	0.750	0.950	0.030	0.037
b	0.250	0.380	0.010	0.015
c	0.090	0.230	0.004	0.009
D	2.900	3.100	0.114	0.122
E	2.900	3.100	0.114	0.122
E1	4.750	5.050	0.187	0.199
e	0.650 BSC		0.026 BSC	
L	0.400	0.800	0.016	0.031
θ	0°	6°	0°	6°

NOTES:

1. Body dimensions do not include mode flash or protrusion.
2. This drawing is subject to change without notice.

TAPE AND REEL INFORMATION

REEL DIMENSIONS

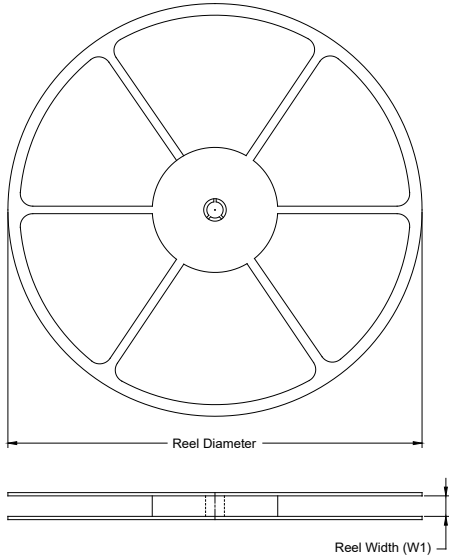

TAPE DIMENSIONS

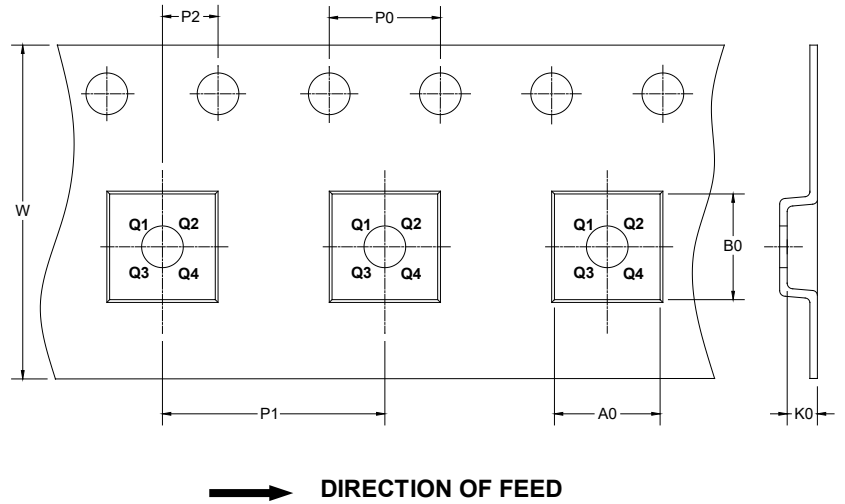

NOTE: The picture is only for reference. Please make the object as the standard.

KEY PARAMETER LIST OF TAPE AND REEL

Package Type	Reel Diameter	Reel Width W1 (mm)	A0 (mm)	B0 (mm)	K0 (mm)	P0 (mm)	P1 (mm)	P2 (mm)	W (mm)	Pin1 Quadrant
UTQFN-1.5×1.5-9L	7"	9.5	1.70	1.70	0.75	4.0	4.0	2.0	8.0	Q1
MSOP-8	13"	12.4	5.20	3.30	1.50	4.0	8.0	2.0	12.0	Q1

D00001

PACKAGE INFORMATION

CARTON BOX DIMENSIONS

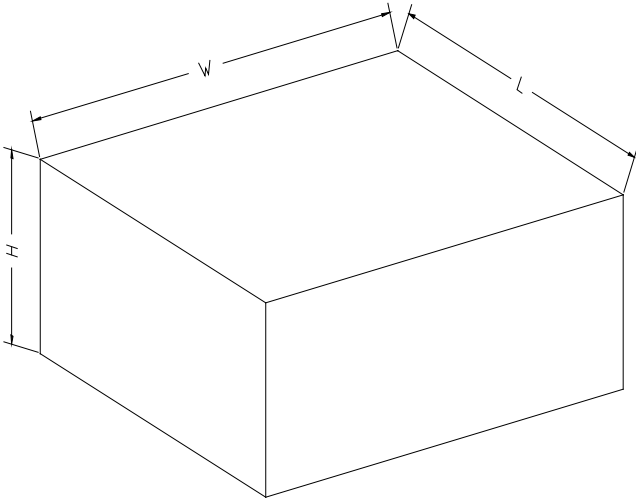

NOTE: The picture is only for reference. Please make the object as the standard.

KEY PARAMETER LIST OF CARTON BOX

Reel Type	Length (mm)	Width (mm)	Height (mm)	Pizza/Carton
7" (Option)	368	227	224	8
7"	442	410	224	18
13"	386	280	370	5

DD0002