

### FEATURES

- Bidirectional Blocking Capability
- GaN-on-Silicon E-Mode HEMT Technology
- Ultra-Low On-Resistance
- RoHS Compliant and Halogen Free

### APPLICATIONS

High-side Load Switch  
 OVP Protection in Smartphone USB Port  
 Switching Circuits in Multiple Power Supply Systems

### ABSOLUTE MAXIMUM RATINGS

PARAMETER	SYMBOL	VALUE	UNITS
Drain-to-Source Voltage	$V_{DS}$	40	V
Source-to-Drain Voltage	$V_{SD}$	40	V
Drain-to-Gate Voltage	$V_{DG}$	40	V
Source-to-Gate Voltage	$V_{SG}$	40	V
Gate-to-Drain Voltage	$V_{GD}$	6	V
Gate-to-Source Voltage	$V_{GS}$	6	V
Drain Current	$I_D$	10	A
Drain Current (Pulse) <sup>(1)</sup>	$I_{DM}$	50	A
Total Dissipation	$P_D$	11	W
Junction Temperature	$T_J$	-40 to +125	°C
Storage Temperature Range	$T_{STG}$	-40 to +150	°C

Stresses beyond those listed in Absolute Maximum Ratings may cause permanent damage to the device. Exposure to absolute maximum rating conditions for extended periods may affect reliability.

NOTE: 1.  $t_{PULSE} = 300\mu s$ .

### PRODUCT SUMMARY

$R_{DS(on)} \ \& \ R_{SD(on)}$ (TYP) $V_{GS} = 5V$	$R_{DS(on)} \ \& \ R_{SD(on)}$ (MAX) $V_{GS} = 5V$	$I_D \ \& \ I_S$ (MAX) $T_C = +25^\circ C$
9mΩ	12mΩ	10A

### PIN CONFIGURATION

(TOP VIEW)

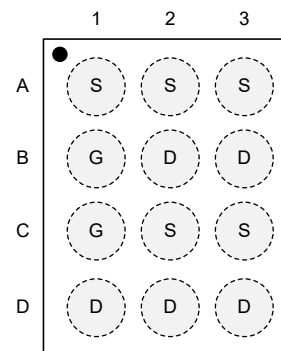

WLCSP-1.2x1.7-12B

### EQUIVALENT CIRCUIT

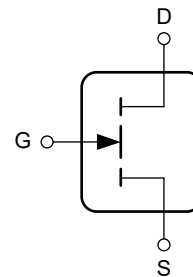

**PACKAGE/ORDERING INFORMATION**

MODEL	PACKAGE DESCRIPTION	SPECIFIED TEMPERATURE RANGE	ORDERING NUMBER	PACKAGE MARKING	PACKING OPTION
SGMGB09340	WLCSP-1.2×1.7-12B	-40°C to +150°C	SGMGB09340TG/TR	09340 XXXXX XX#XX	Tape and Reel, 2500

**MARKING INFORMATION**

NOTE: XXXXX = Date Code, Trace Code and Vendor Code. XX#XX = Coordinate Information and Wafer ID Number.

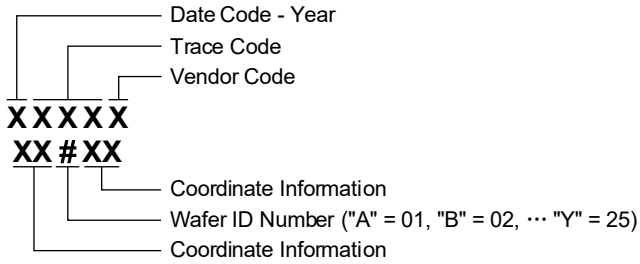

Green (RoHS & HSF): SG Micro Corp defines "Green" to mean Pb-Free (RoHS compatible) and free of halogen substances. If you have additional comments or questions, please contact your SGMICRO representative directly.

**DISCLAIMER**

SG Micro Corp reserves the right to make any change in circuit design, or specifications without prior notice.

**THERMAL RESISTANCE**

PARAMETER	SYMBOL	TYP	UNITS
Junction-to-Ambient Thermal Resistance <sup>(1)</sup>	R <sub>θJA</sub>	67.35	°C/W
Junction-to-Case Thermal Resistance	R <sub>θJC_TOP</sub>	1.4	°C/W
	R <sub>θJC_BOTTOM</sub>	8.88	

NOTE: 1. R<sub>θJA</sub> is determined with the device mounted on one square inch of copper pad, single layer 2oz copper on FR4 board.

## ELECTRICAL CHARACTERISTICS

(T<sub>J</sub> = +25°C, unless otherwise noted.)

PARAMETER	SYMBOL	CONDITIONS	MIN	TYP	MAX	UNITS	
<b>Static Characteristics</b>							
Drain-to-Source Breakdown Voltage	V <sub>BR_DSS</sub>	V <sub>G</sub> = V <sub>S</sub> = 0V, I <sub>DS</sub> = 500μA	40			V	
Source-to-Drain Breakdown Voltage	V <sub>BR_SDS</sub>	V <sub>G</sub> = V <sub>D</sub> = 0V, I <sub>SD</sub> = 500μA	40			V	
Zero Gate Voltage Drain Current	I <sub>DSS</sub>	V <sub>G</sub> = V <sub>S</sub> = 0V, V <sub>D</sub> = 40V			20	μA	
Zero Gate Voltage Source Current	I <sub>SDS</sub>	V <sub>G</sub> = V <sub>D</sub> = 0V, V <sub>S</sub> = 40V			20	μA	
Gate-to-Drain Leakage Current	I <sub>GDS</sub>	T <sub>J</sub> = +25°C, V <sub>D</sub> = V <sub>S</sub> = 0V	V <sub>G</sub> = 5V		0.4	5	μA
			V <sub>G</sub> = -5V	-30			
			V <sub>G</sub> = 6V		4	30	
			V <sub>G</sub> = -6V	-40			
		T <sub>J</sub> = +85°C, V <sub>D</sub> = V <sub>S</sub> = 0V	V <sub>G</sub> = 5V		0.5	5	
			V <sub>G</sub> = -5V	-30			
			V <sub>G</sub> = 6V		5	30	
			V <sub>G</sub> = -6V	-40			
Gate-to-Source Leakage Current	I <sub>GSS</sub>	T <sub>J</sub> = +25°C, V <sub>D</sub> = V <sub>S</sub> = 0V	V <sub>G</sub> = 5V		0.4	5	μA
			V <sub>G</sub> = -5V	-30			
			V <sub>G</sub> = 6V		4	30	
			V <sub>G</sub> = -6V	-40			
		T <sub>J</sub> = +85°C, V <sub>D</sub> = V <sub>S</sub> = 0V	V <sub>G</sub> = 5V		0.5	5	
			V <sub>G</sub> = -5V	-30			
			V <sub>G</sub> = 6V		5	30	
			V <sub>G</sub> = -6V	-40			
Gate-to-Drain Threshold Voltage	V <sub>GD_TH</sub>	V <sub>G</sub> = V <sub>S</sub> , V <sub>D</sub> = 0V, I <sub>SD</sub> = 1mA	0.8		2.4	V	
Gate-to-Source Threshold Voltage	V <sub>GS_TH</sub>	V <sub>G</sub> = V <sub>D</sub> , V <sub>S</sub> = 0V, I <sub>DS</sub> = 1mA	0.8		2.4	V	
Drain-to-Source On-State Resistance	R <sub>DSON</sub>	V <sub>GS</sub> = 5V, V <sub>S</sub> = 0V, I <sub>DS</sub> = 10A		9	12	mΩ	
Source-to-Drain On-State Resistance	R <sub>SDON</sub>	V <sub>GD</sub> = 5V, V <sub>D</sub> = 0V, I <sub>SD</sub> = 10A		9	12	mΩ	
Gate Resistance	R <sub>G</sub>	f = 1MHz		3.5		Ω	
<b>Dynamic Characteristics</b>							
Input Capacitance	C <sub>ISS</sub>	V <sub>G</sub> = 0V, V <sub>D</sub> = 20V, or V <sub>G</sub> = 0V, V <sub>S</sub> = 20V		410		pF	
Output Capacitance	C <sub>OSS</sub>			177			
Reverse Transfer Capacitance	C <sub>RSS</sub>			104			
Total Gate Charge	Q <sub>G</sub>	V <sub>G</sub> = 5V	V <sub>D</sub> = 20V, I <sub>D</sub> = 10A		7.3	nC	
			V <sub>S</sub> = 20V, I <sub>S</sub> = 10A		7.3		
Gate-to-Drain Charge	Q <sub>GD</sub>	V <sub>D</sub> = 0V, V <sub>S</sub> = 20V, I <sub>SD</sub> = 10A		0.9		nC	
		V <sub>D</sub> = 20V, V <sub>S</sub> = 0V, I <sub>DS</sub> = 10A		3.9			
Gate-to-Source Charge	Q <sub>GS</sub>	V <sub>D</sub> = 20V, V <sub>S</sub> = 0V, I <sub>DS</sub> = 10A		0.9		nC	
		V <sub>D</sub> = 0V, V <sub>S</sub> = 20V, I <sub>SD</sub> = 10A		3.9			
Output Charge	Q <sub>OSS</sub>	V <sub>G</sub> = 0V	V <sub>D</sub> = 20V		5.6	nC	
			V <sub>S</sub> = 20V		5.6		

TYPICAL PERFORMANCE CHARACTERISTICS

Figure 1 Typical Output Characteristics ( $T_J = 25\text{ }^\circ\text{C}$ )

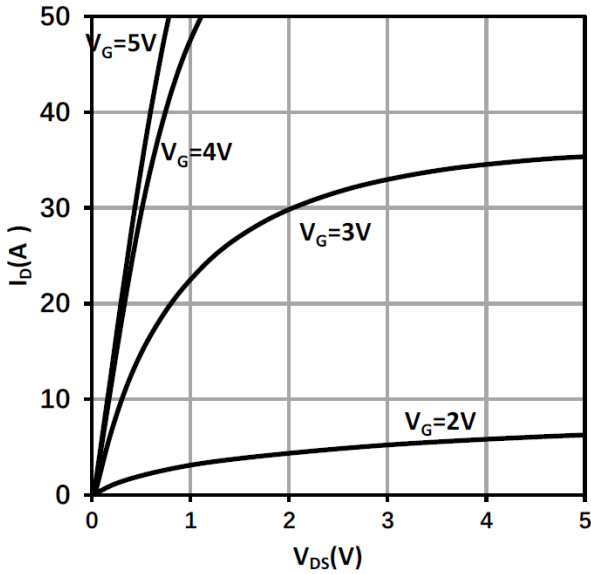

Figure 2 Typical Output Characteristics ( $T_J = 125\text{ }^\circ\text{C}$ )

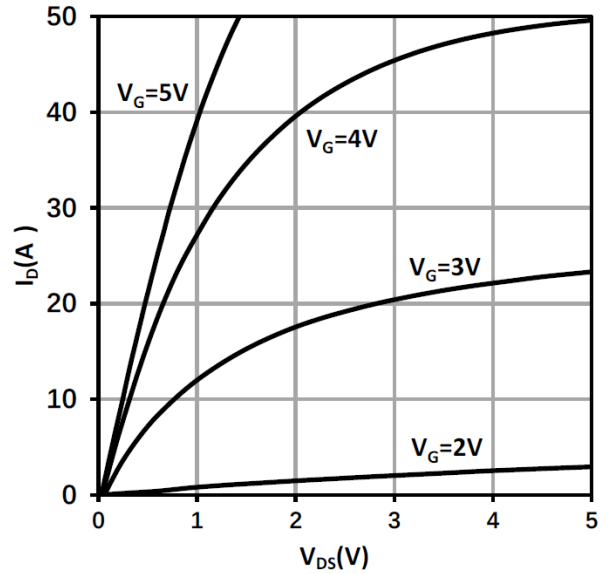

Figure 3 Typical Drain On-state Resistance ( $T_J = 25\text{ }^\circ\text{C}$ )

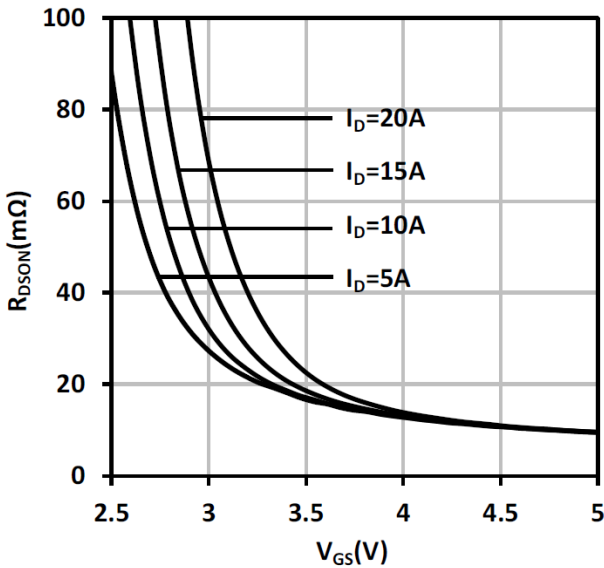
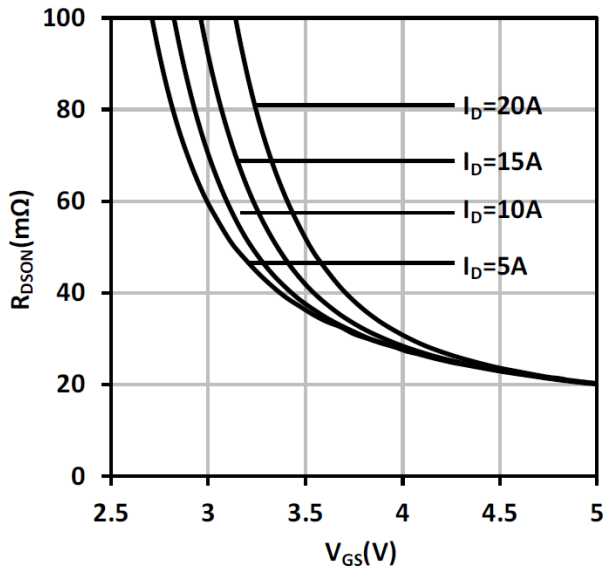

Figure 4 Typical Drain On-state Resistance ( $T_J = 125\text{ }^\circ\text{C}$ )



TYPICAL PERFORMANCE CHARACTERISTICS (continued)

Figure 5 Typical On Resistance vs. Temperature

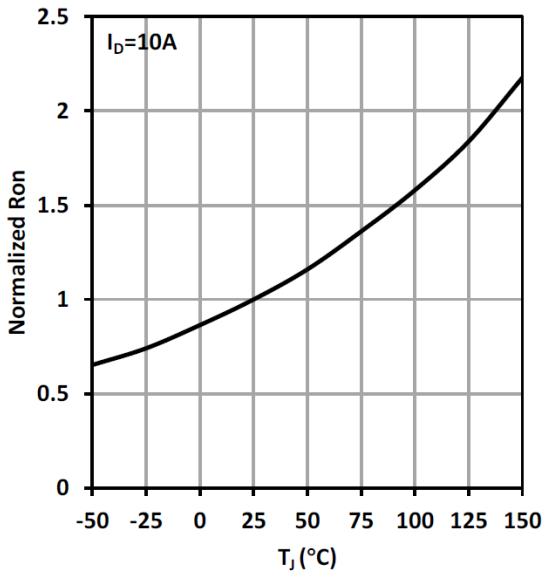

Figure 6 Typical Transfer Characteristics

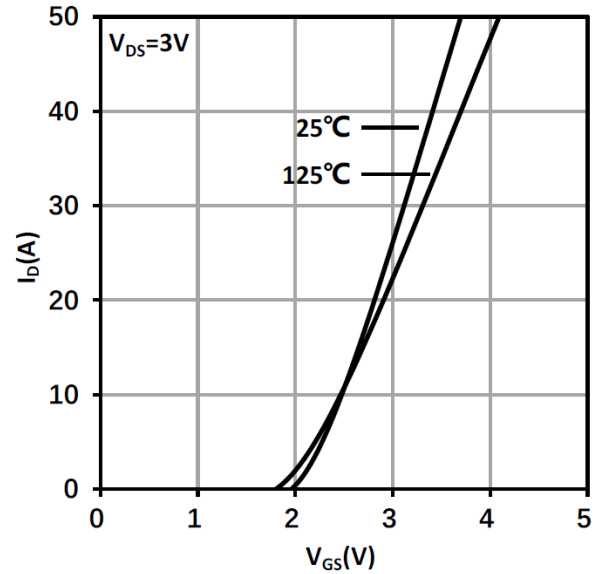

Figure 7 Typ. Reverse Drain-Source Characteristics ( $V_{GS} \leq 0V$ ,  $T_J = 25^\circ C$ )

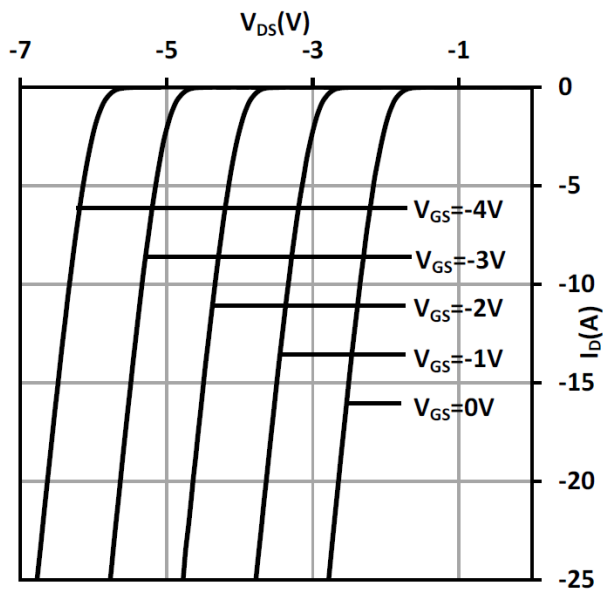
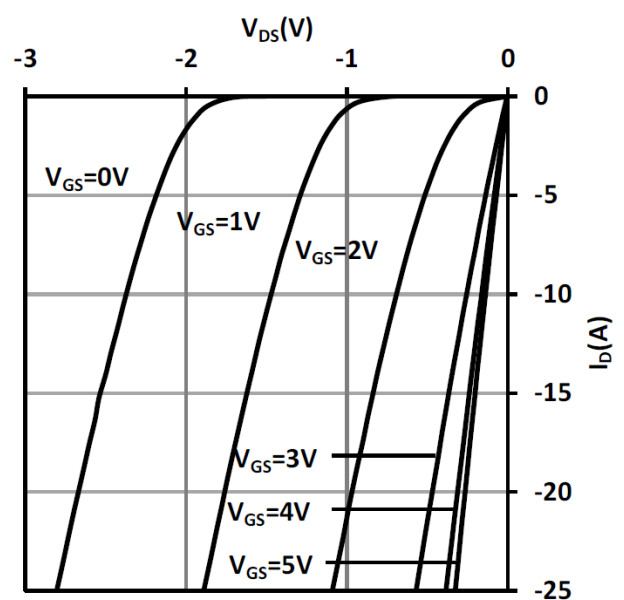

Figure 8 Typ. Reverse Drain-Source Characteristics ( $V_{GS} \geq 0V$ ,  $T_J = 25^\circ C$ )



TYPICAL PERFORMANCE CHARACTERISTICS (continued)

Figure 9 Typ. Reverse Drain-Source Characteristics  
( $V_{GS} \leq 0V$ ,  $T_J = 125^\circ C$ )

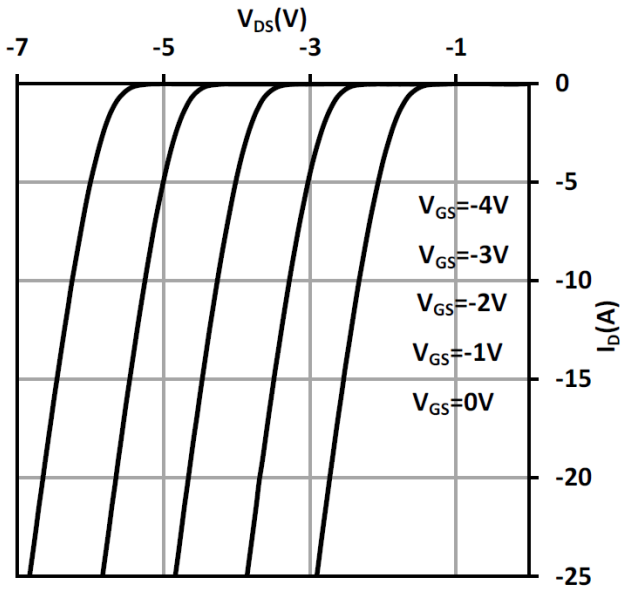

Figure 10 Typ. Reverse Drain-Source Characteristics  
( $V_{GS} \geq 0V$ ,  $T_J = 125^\circ C$ )

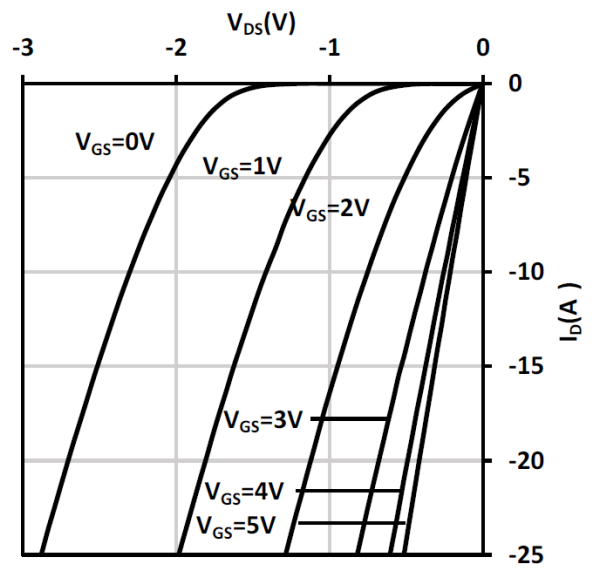

Figure 11 Typ. Capacitances Characteristics

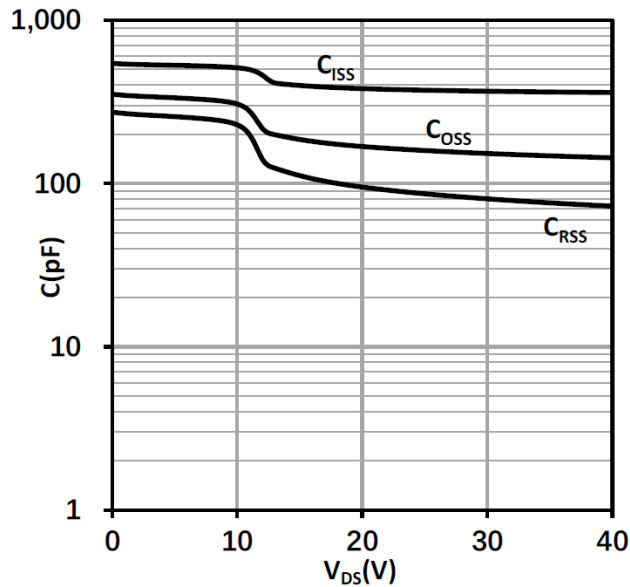
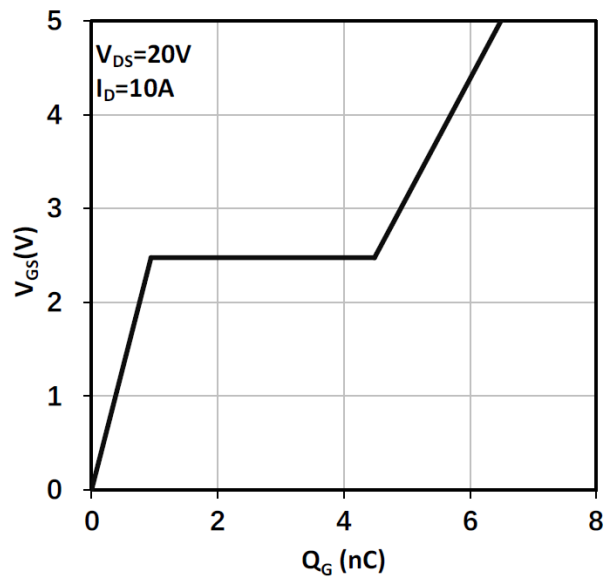

Figure 12 Typ. Gate Charge



TYPICAL PERFORMANCE CHARACTERISTICS (continued)

Figure 13 Normalized Threshold Voltage vs. Temp.

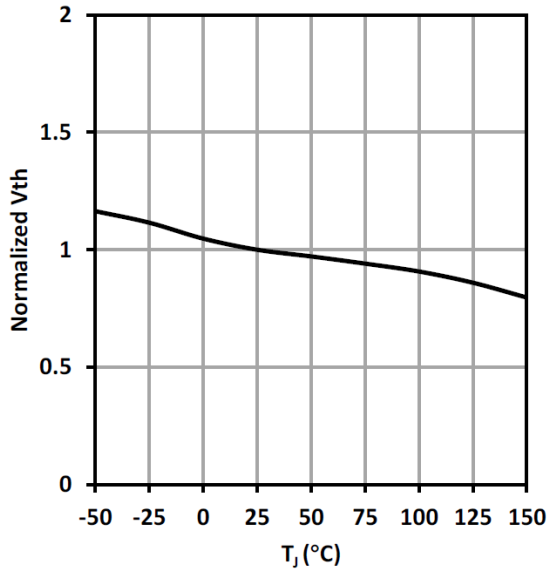

Figure 14 Output Charge

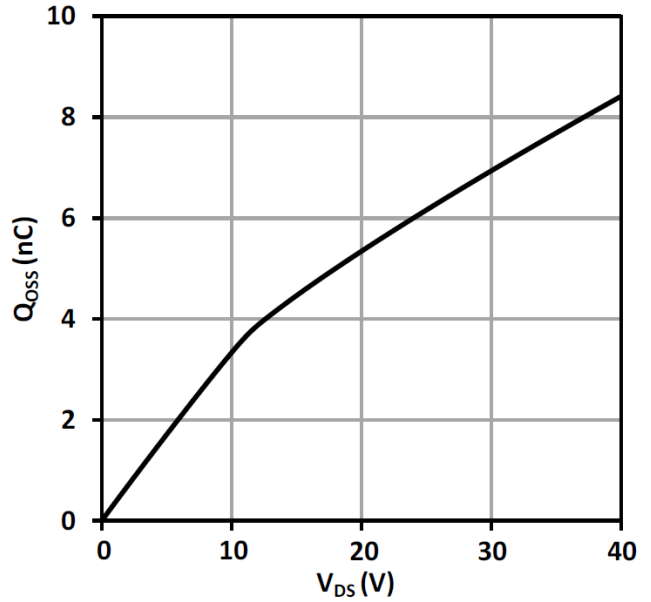

Figure 15 Output Capacitance Stored Energy

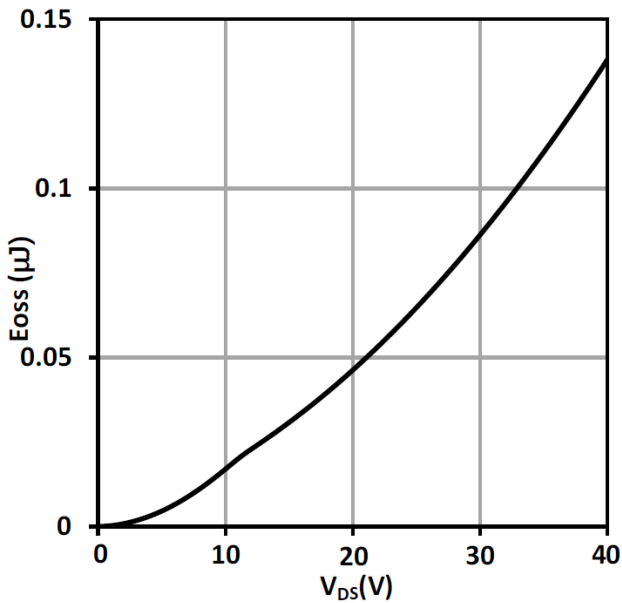
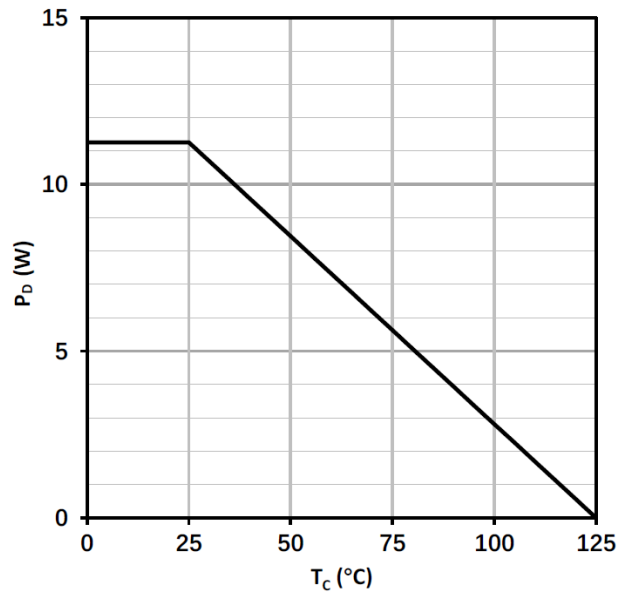

Figure 16 Power Dissipation



TYPICAL PERFORMANCE CHARACTERISTICS (continued)

Figure 17 Safe Operating Area

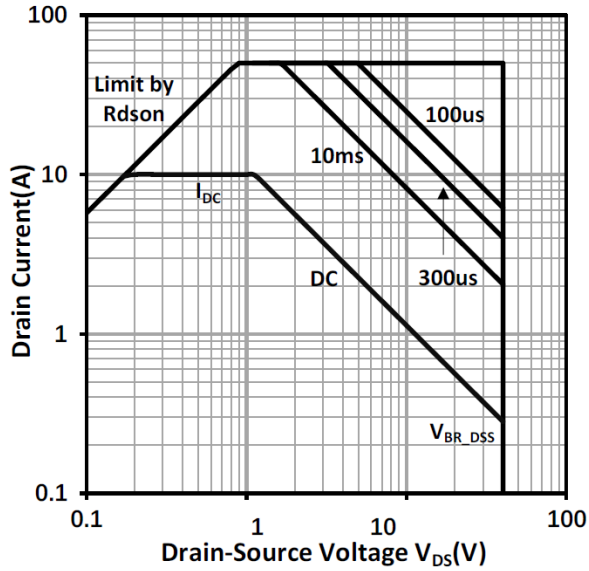
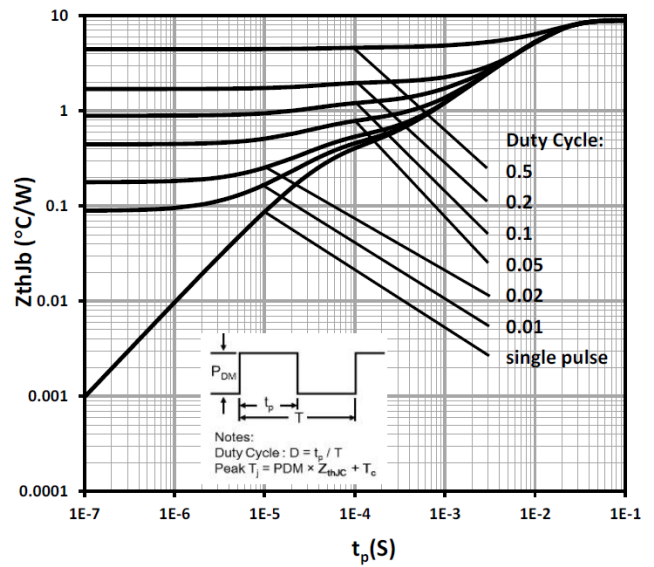

Figure 18 Max. Transient Thermal Impedance



REVISION HISTORY

NOTE: Page numbers for previous revisions may differ from page numbers in the current version.

Changes from Original to REV.A (JUNE 2026)	Page
Changed from product preview to production data.....	All

# PACKAGE INFORMATION

## PACKAGE OUTLINE DIMENSIONS

### WLCSP-1.2×1.7-12B

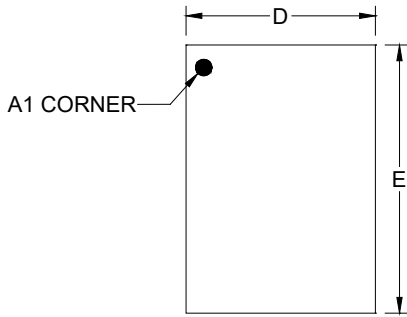

**TOP VIEW**

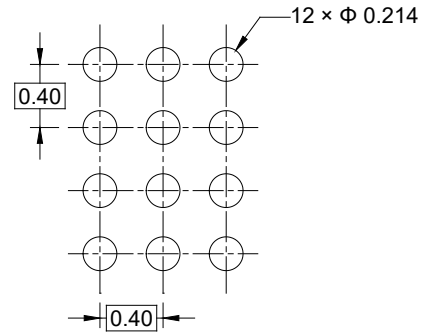

**RECOMMENDED LAND PATTERN (Unit: mm)**

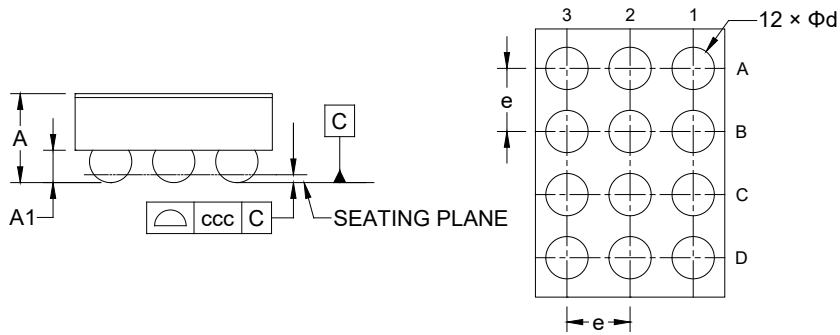

**SIDE VIEW**

**BOTTOM VIEW**

Symbol	Dimensions In Millimeters		
	MIN	NOM	MAX
A	-	-	0.611
A1	0.175	-	0.235
D	1.170	-	1.230
E	1.670	-	1.730
d	0.238	-	0.298
e	0.400 BSC		
ccc	0.050		

NOTE: This drawing is subject to change without notice.

# PACKAGE INFORMATION

## TAPE AND REEL INFORMATION

### REEL DIMENSIONS

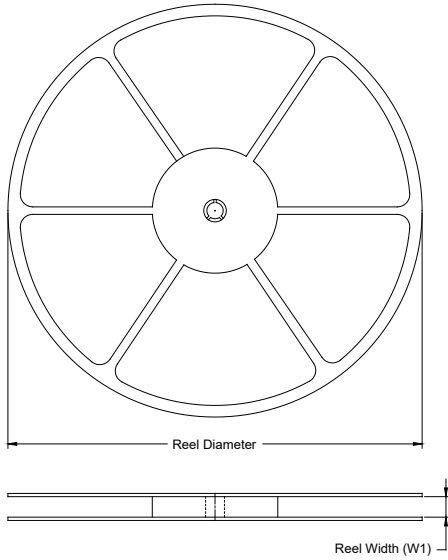

### TAPE DIMENSIONS

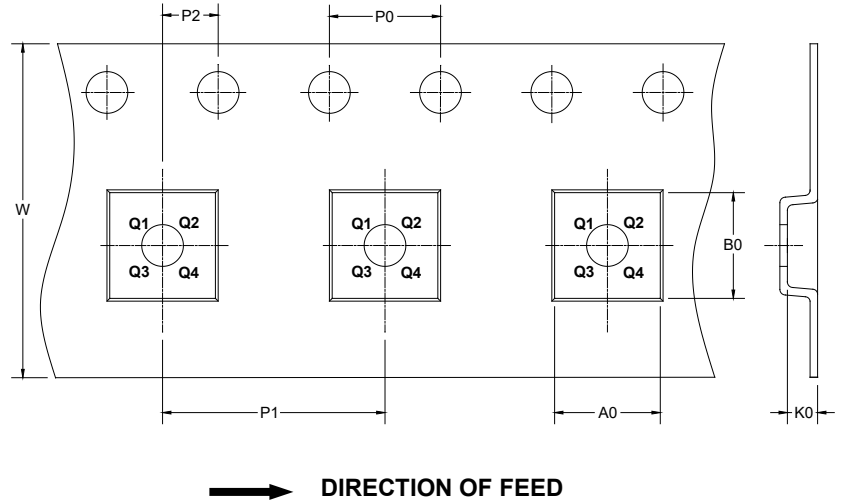

NOTE: The picture is only for reference. Please make the object as the standard.

### KEY PARAMETER LIST OF TAPE AND REEL

Package Type	Reel Diameter	Reel Width W1 (mm)	A0 (mm)	B0 (mm)	K0 (mm)	P0 (mm)	P1 (mm)	P2 (mm)	W (mm)	Pin1 Quadrant
WLCSP-1.2×1.7-12B	7"	9.0	1.31	1.87	0.71	4.0	4.0	2.0	8.0	Q1

DD0001

# PACKAGE INFORMATION

## CARTON BOX DIMENSIONS

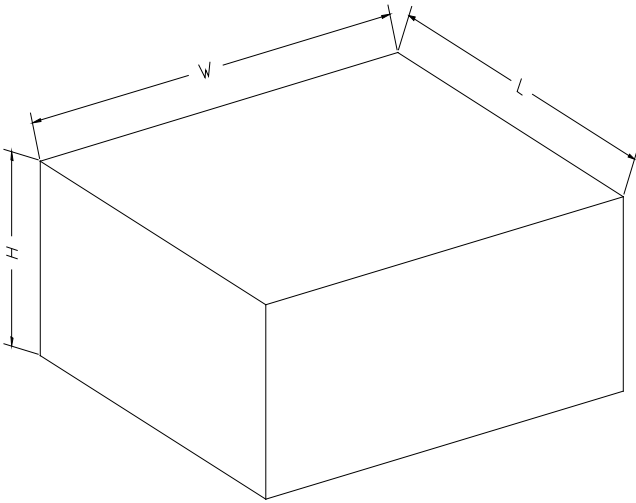

NOTE: The picture is only for reference. Please make the object as the standard.

## KEY PARAMETER LIST OF CARTON BOX

Reel Type	Length (mm)	Width (mm)	Height (mm)	Pizza/Carton
7" (Option)	368	227	224	8
7"	442	410	224	18

D00002