

## GENERAL DESCRIPTION

The SGM61434xQ is a frequency programmable, internally compensated Buck converter with an integrated high-side MOSFET. It provides up to 3.5A output current capability over a wide input range from 4V to 40V, which accommodates a variety of Buck applications in an automotive input environment. Only 47 $\mu$ A (TYP) sleep-mode quiescent current makes the SGM61434xQ suitable for battery powered systems. An ultra-low 2.1 $\mu$ A (TYP) shutdown current can further prolong battery life.

The SGM61434xQ uses peak-current mode control with constant switching frequency to provide optimal output voltage accuracy and fast loop response. Switching frequency is widely adjustable, which enables optimization of either efficiency or solution size. Internal loop compensation makes it easy to use and eliminates many external components. Frequency spread spectrum version (SGM61434BQ) is also available for reducing EMI.

The SGM61434xQ employs adjustable soft-start time to prevent high startup inrush current. An enable pin is provided for simplification of on/off control and system power sequencing. Protection features include thermal shutdown, input under-voltage lockout, cycle-by-cycle current limit, output over-voltage protection.

The device is AEC-Q100 qualified (Automotive Electronics Council (AEC) standard Q100 Grade 1) and it is suitable for automotive applications.

The SGM61434xQ is available in Green SOIC-8 (Exposed Pad) and TDFN-4 $\times$ 4-10AL packages.

## APPLICATIONS

General Purpose Automotive Battery Regulation  
 Automotive ADAS or Surround View  
 Cluster and Infotainment  
 Telematics Control Unit

## FEATURES

- **AEC-Q100 Qualified for Automotive Applications**  
 Device Temperature Grade 1  
 $T_A = -40^{\circ}\text{C}$  to  $+125^{\circ}\text{C}$
- **Wide Input Voltage Range: 4V to 40V**
- **High Continuous Output Current: Up to 3.5A**
- **Ultra-Low Quiescent Current: 47 $\mu$ A (TYP)**
- **Ultra-Low Shutdown Current: 2.1 $\mu$ A (TYP)**
- **Integrated High-side MOSFET**
  - ♦ **SOIC Package: 80m $\Omega$**
  - ♦ **TDFN Package: 90m $\Omega$**
- **Adjustable Switching Frequency: 200kHz to 2.5MHz**
- **Frequency Synchronization for External Clock**
- **Spread Spectrum Option for Reduced EMI**
  - ♦ **SGM61434AQ: No Spread Spectrum**
  - ♦ **SGM61434BQ: Spread Spectrum**
- **Peak Current Mode Control**
- **Internal Compensation for Ease of Use**
- **Support High Duty Cycle Operation**
- **Precise Enable Input**
- **Adjustable Soft-Start Time**
- **Available in Green SOIC-8 (Exposed Pad) and TDFN-4 $\times$ 4-10AL Packages**

## TYPICAL APPLICATION

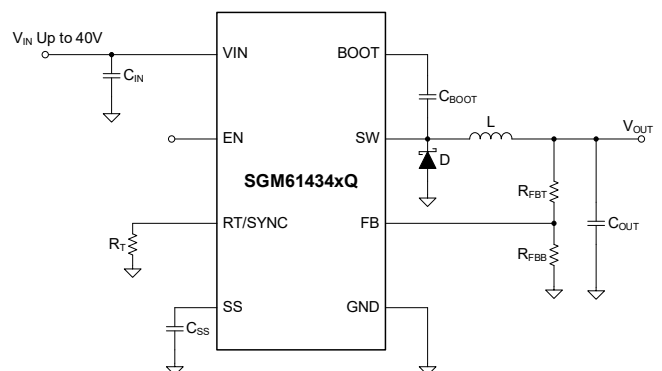

Figure 1. Typical Application Circuit (SOIC Package)

**PACKAGE/ORDERING INFORMATION**

MODEL	PACKAGE DESCRIPTION	SPECIFIED TEMPERATURE RANGE	ORDERING NUMBER	PACKAGE MARKING	PACKING OPTION
SGM61434AQ	SOIC-8 (Exposed Pad)	-40°C to +125°C	SGM61434AQPS8G/TR	0G9PS8 XXXXX	Tape and Reel, 4000
	TDFN-4x4-10AL	-40°C to +125°C	SGM61434AQTHH10G/TR	0GLTHH10 XXXXX	Tape and Reel, 3000
SGM61434BQ	SOIC-8 (Exposed Pad)	-40°C to +125°C	SGM61434BQPS8G/TR	0GAPS8 XXXXX	Tape and Reel, 4000
	TDFN-4x4-10AL	-40°C to +125°C	SGM61434BQTHH10G/TR	0GMTHH10 XXXXX	Tape and Reel, 3000

**MARKING INFORMATION**

NOTE: XXXXX = Date Code, Trace Code and Vendor Code.

**XXXXX**

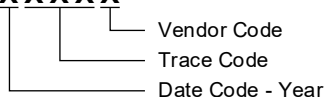

Green (RoHS & HSF): SG Micro Corp defines "Green" to mean Pb-Free (RoHS compatible) and free of halogen substances. If you have additional comments or questions, please contact your SGMICRO representative directly.

**ABSOLUTE MAXIMUM RATINGS**

Input Voltage	
VIN, EN to GND .....	-0.3V to 44V
BOOT to GND .....	-0.3V to 49V
SS to GND .....	-0.3V to 5V
FB to GND.....	-0.3V to 6V
RT/SYNC to GND .....	-0.3V to 3.6V
PGOOD to GND.....	-0.3V to 6V
Output Voltage	
BOOT-SW .....	6V
SW .....	-3V to 44V
Package Thermal Resistance	
SOIC-8 (Exposed Pad), $\theta_{JA}$ .....	38.9°C/W
SOIC-8 (Exposed Pad), $\theta_{JB}$ .....	12.3°C/W
SOIC-8 (Exposed Pad), $\theta_{JC(TOP)}$ .....	46.9°C/W
SOIC-8 (Exposed Pad), $\theta_{JC(BOT)}$ .....	1.5°C/W
TDFN-4x4-10AL, $\theta_{JA}$ .....	31.4°C/W
TDFN-4x4-10AL, $\theta_{JB}$ .....	10.8°C/W
TDFN-4x4-10AL, $\theta_{JC(TOP)}$ .....	24.9°C/W
TDFN-4x4-10AL, $\theta_{JC(BOT)}$ .....	2.8°C/W
Package Thermal Characterization Parameter	
SOIC-8 (Exposed Pad), $\psi_{JT}$ .....	3.1°C/W
SOIC-8 (Exposed Pad), $\psi_{JB}$ .....	12.1°C/W
TDFN-4x4-10AL, $\psi_{JT}$ .....	0.3°C/W
TDFN-4x4-10AL, $\psi_{JB}$ .....	9.4°C/W
Junction Temperature.....	+150°C
Storage Temperature Range .....	-65°C to +150°C
Lead Temperature (Soldering, 10s).....	+260°C

ESD Susceptibility <sup>(1)(2)</sup>

HBM .....	±4000V
CDM .....	±1000V

NOTES:

1. For human body model (HBM), all pins comply with AEC-Q100-002 specification.
2. For charged device model (CDM), all pins comply with AEC-Q100-011 specification.

**RECOMMENDED OPERATING CONDITIONS**

Buck Regulator	
VIN.....	4V to 40V
VOUT.....	0.8V to 28V
BOOT .....	45V
SW .....	-1V to 40V
FB.....	0V to 5V
Control	
EN.....	0 to 40V
RT/SYNC.....	0V to 3.3V
SS.....	0V to 0.3V
PGOOD to GND .....	0V to 5V
Switching Frequency Range	
RT Mode .....	200kHz to 2500kHz
SYNC Mode.....	250kHz to 2300kHz
Junction Temperature Range .....	-40°C to +125°C

**OVERSTRESS CAUTION**

Stresses beyond those listed in Absolute Maximum Ratings may cause permanent damage to the device. Exposure to absolute maximum rating conditions for extended periods may affect reliability. Functional operation of the device at any conditions beyond those indicated in the Recommended Operating Conditions section is not implied.

**ESD SENSITIVITY CAUTION**

This integrated circuit can be damaged if ESD protections are not considered carefully. SGMICRO recommends that all integrated circuits be handled with appropriate precautions.

Failure to observe proper handling and installation procedures can cause damage. ESD damage can range from subtle performance degradation to complete device failure. Precision integrated circuits may be more susceptible to damage because even small parametric changes could cause the device not to meet the published specifications.

**DISCLAIMER**

SG Micro Corp reserves the right to make any change in circuit design, or specifications without prior notice.

**PIN CONFIGURATIONS**

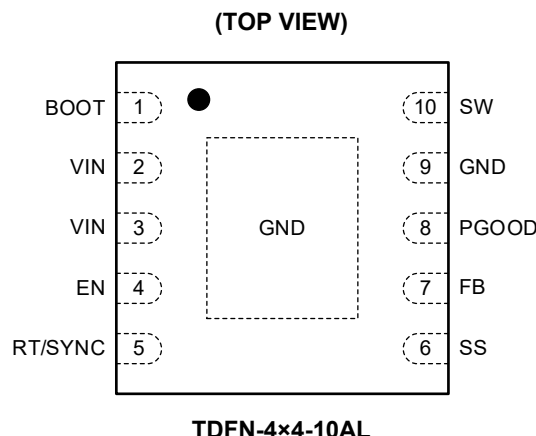
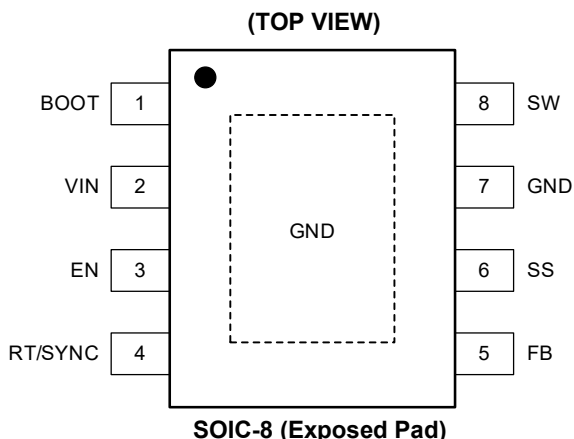

**PIN DESCRIPTION**

PIN		NAME	TYPE	FUNCTION
SOIC-8 (Exposed Pad)	TDFN-4x4-10AL			
1	1	BOOT	P	Bootstrap Supply Voltage for Internal High-side Driver. Connect a high-quality 100nF capacitor as close as possible to the IC between this pin and the SW pin.
2	2, 3	VIN	P	Input Supply to Regulator. Connect to a 4V to 40V power source.
3	4	EN	A	Enable Input to Converter. Pull this pin below the low threshold to shut the chip down. Pull it above the high threshold or float to enable the chip. This pin can be connected to VIN pin via a resistor if the shutdown feature is not required or to a resistor divider to adjust UVLO threshold.
4	5	RT/SYNC	A	Resistor Timing or External Clock Input. Connect an external resistor between this pin and the ground to set the switching frequency or connect the pin to a synchronization clock.
6	6	SS	A	Soft-Start Control Pin. Connect a capacitor to this pin to set soft-start time.
5	7	FB	A	Feedback Input to Regulator. Connect to tap point of feedback voltage divider. Do not float. Do not ground.
—	8	PGOOD	A	Open-Drain Power Good Flag Output. Connect to suitable voltage supply through a pull-up resistor. Can be left open when not used.
7	9	GND	G	Power and Analog Ground Terminal. Ground reference for internal references, logic and regulated output voltage. For the reason, care must be taken in PCB layout.
8	10	SW	P	Switching Output of the Regulator. A high-side power MOSFET is internally connected to this pin. Connect to power inductor and bootstrap capacitor.
Exposed Pad	Exposed Pad	GND	G	Thermal Exposed Pad. Connect to ground plane on PCB. It is the main thermal relief path for the die.

NOTE: A = analog, P = power, G = ground.

**ELECTRICAL CHARACTERISTICS**

(V<sub>IN</sub> = 4V to 40V, T<sub>J</sub> = -40°C to +125°C, typical values are at T<sub>J</sub> = +25°C, V<sub>IN</sub> = 12V, unless otherwise noted.)

PARAMETER	SYMBOL	CONDITIONS	MIN	TYP	MAX	UNITS	
<b>Power Supply (VIN Pin)</b>							
Operating Input Voltage	V <sub>IN</sub>		4		40	V	
Under-Voltage Lockout Threshold	V <sub>UVLO</sub>	Rising threshold	3.5	3.7	4	V	
Under-Voltage Lockout Threshold Hysteresis	V <sub>UVLO_HYS</sub>	Hysteresis		300		mV	
Shutdown Supply Current	I <sub>SD</sub>	V <sub>EN</sub> = 0V, T <sub>J</sub> = +25°C, V <sub>IN</sub> = 4V to 40V		2.1	5.0	$\mu$ A	
Operating Quiescent Current (Non-Switching)	I <sub>Q</sub>	V <sub>FB</sub> = 1V	25	47	65	$\mu$ A	
<b>Enable (EN Pin)</b>							
Enable Threshold Voltage	V <sub>EN_TH</sub>	Rising threshold	1.11	1.20	1.38	V	
Enable Hysteresis Threshold Voltage	V <sub>EN_HYS</sub>	Hysteresis voltage		80		mV	
EN Pin Current	I <sub>EN_PIN</sub>	Enable rising threshold +50mV		-4.4		$\mu$ A	
		Enable falling threshold -50mV		-0.9			
EN Hysteresis Current	I <sub>EN_HYS</sub>	Rising threshold		-3.5		$\mu$ A	
<b>External Soft-Start</b>							
SS Pin Current	I <sub>SS</sub>	T <sub>J</sub> = +25°C		3		$\mu$ A	
<b>Power Good (PGOOD Pin) <sup>(1)</sup></b>							
Power Good Flag Under-Voltage Tripping Threshold	V <sub>PG_UV</sub>	% of V <sub>REF</sub>	Power good		94	%	
			Power bad		91		
Power Good Flag Over-Voltage Tripping Threshold	V <sub>PG_OV</sub>	% of V <sub>REF</sub>	Power bad		109	%	
			Power good		105		
Power Good Flag Recovery Hysteresis	V <sub>PG_HYS</sub>	Under-voltage		3	%		
		Over-voltage		4			
PGOOD Leakage Current at High Level Output	I <sub>PG</sub>	V <sub>PULL_UP</sub> = 5V		10	200	nA	
PGOOD Low Level Output Voltage	V <sub>PG_LOW</sub>	I <sub>PULL_UP</sub> = 1mA		0.1		V	
Minimum VIN for Valid PGOOD Output	V <sub>IN_PG_MIN</sub>	V <sub>PULL_UP</sub> < 5V at I <sub>PULL_UP</sub> = 100 $\mu$ A		1	1.5	V	
<b>Voltage Reference (FB Pin)</b>							
Reference Voltage	V <sub>REF</sub>	T <sub>J</sub> = +25°C	0.740	0.750	0.768	V	
		T <sub>J</sub> = -40°C to +125°C	0.735	0.750	0.772		
<b>High-side MOSFET</b>							
On-Resistance	R <sub>DSON</sub>	V <sub>IN</sub> = 12V, BOOT to SW = 5V	SOIC package		80	150	m $\Omega$
			TDFN package		90	160	
<b>High-side MOSFET Current Limit</b>							
Current Limit	I <sub>LIM</sub>	T <sub>J</sub> = +25°C, close loop, V <sub>IN</sub> = 12V, V <sub>OUT</sub> = 5V, f <sub>SW</sub> = 2.1MHz, L = 1.5 $\mu$ H	4.5	5.4	6.3	A	
<b>Thermal Performance</b>							
Thermal Shutdown Threshold	T <sub>SD</sub>			173		°C	
Thermal Shutdown Hysteresis	T <sub>HYS</sub>			15		°C	

NOTE:

1. Valid only for TDFN package.

## TIMING PARAMETERS

(V<sub>IN</sub> = 4V to 40V, T<sub>J</sub> = -40°C to +125°C, unless otherwise noted.)

PARAMETER	SYMBOL	CONDITIONS	MIN	TYP	MAX	UNITS
Switching Frequency	f <sub>SW</sub>	R <sub>T</sub> = 11.5k $\Omega$	1860	1990	2120	kHz
Switching Frequency Range at SYNC Mode			250		2300	
Switching Frequency Dithering <sup>(1) (2)</sup>	f <sub>DITHER</sub>	Spread spectrum option, frequency dithering over center frequency		$\pm$ 6%		
SYNC Clock High Level Threshold	V <sub>SYNC_H</sub>		1.7			V
SYNC Clock Low Level Threshold	V <sub>SYNC_L</sub>				0.5	V
Minimum SYNC Input Pulse Width <sup>(2)</sup>	t <sub>SYNC_MIN</sub>	Measured at 500kHz, V <sub>SYNC_H</sub> > 3V, V <sub>SYNC_L</sub> < 0.3V		30		ns
PLL Lock in Time <sup>(2)</sup>	t <sub>LOCK_IN</sub>	Measured at 500kHz		100		$\mu$ s
Minimum Controllable On Time <sup>(2)</sup>	t <sub>ON_MIN</sub>	V <sub>IN</sub> = 30V, V <sub>OUT</sub> = 5V, f <sub>SW</sub> = 2.1MHz, I <sub>OUT</sub> = 3.5A		95		ns
Maximum Duty Cycle <sup>(2)</sup>	D <sub>MAX</sub>			98		%

**NOTE:**

1. Valid only for SGM61434BQ.
2. Guaranteed by design, not tested in production.

**TYPICAL PERFORMANCE CHARACTERISTICS**

T<sub>A</sub> = +25°C, V<sub>IN</sub> = 12V, V<sub>OUT</sub> = 5V, f<sub>SW</sub> = 2.1MHz, L = 1.5μH, C<sub>OUT</sub> = 47μF + 10μF, unless otherwise noted.

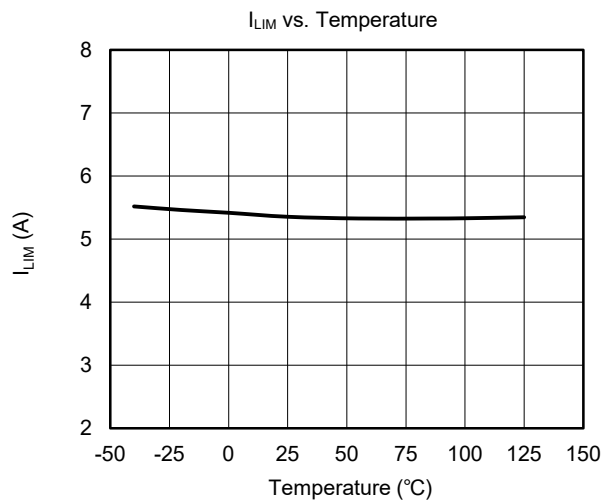
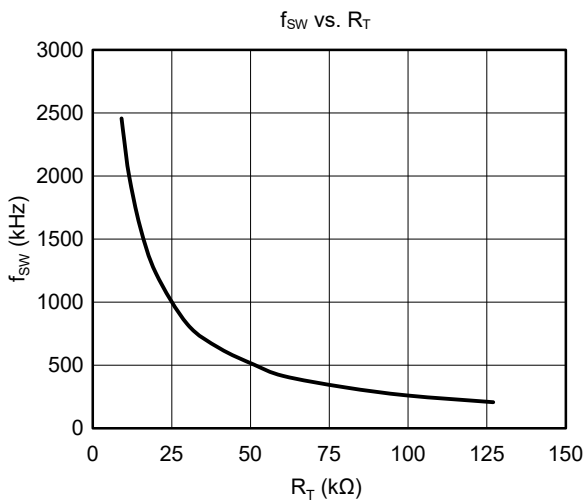
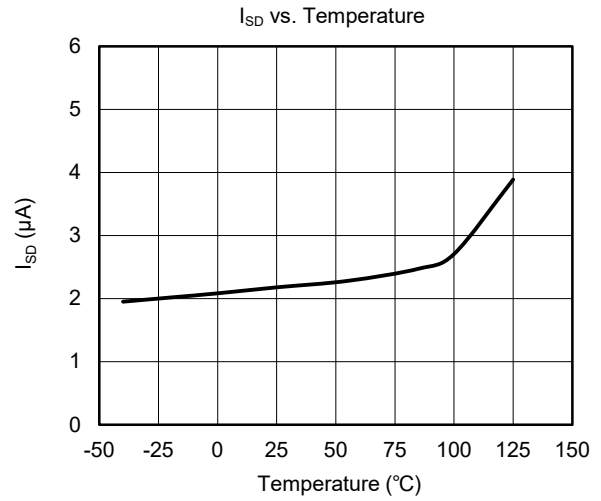
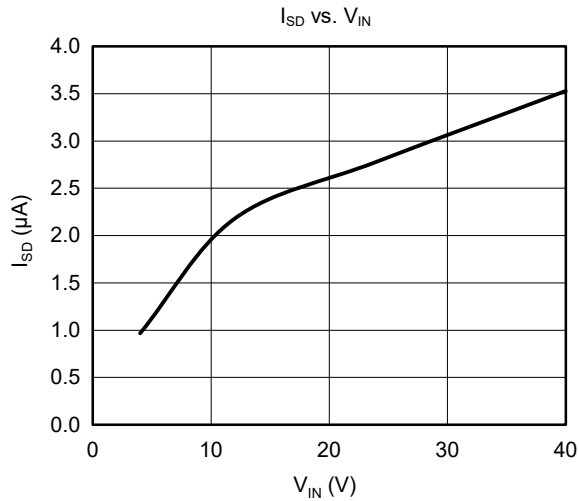
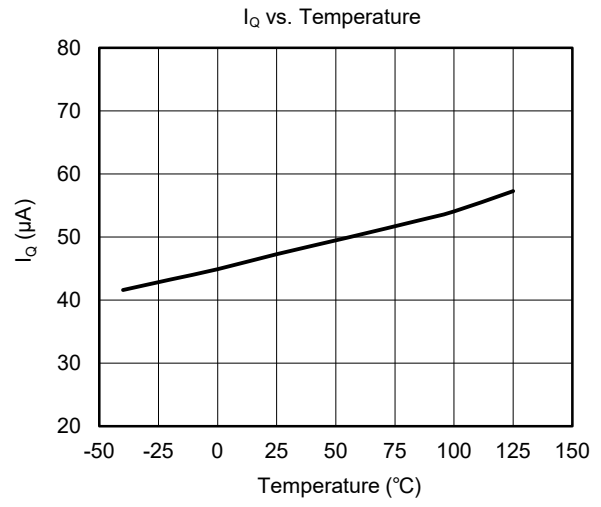
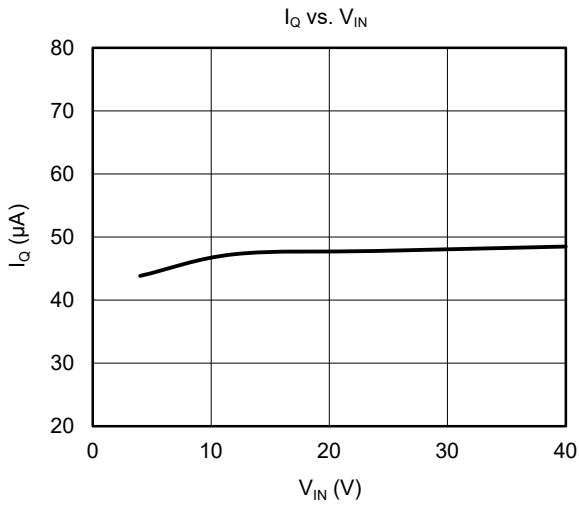

**TYPICAL PERFORMANCE CHARACTERISTICS (continued)**

T<sub>A</sub> = +25°C, V<sub>IN</sub> = 12V, V<sub>OUT</sub> = 5V, f<sub>SW</sub> = 2.1MHz, L = 1.5 $\mu$ H, C<sub>OUT</sub> = 47 $\mu$ F + 10 $\mu$ F, unless otherwise noted.

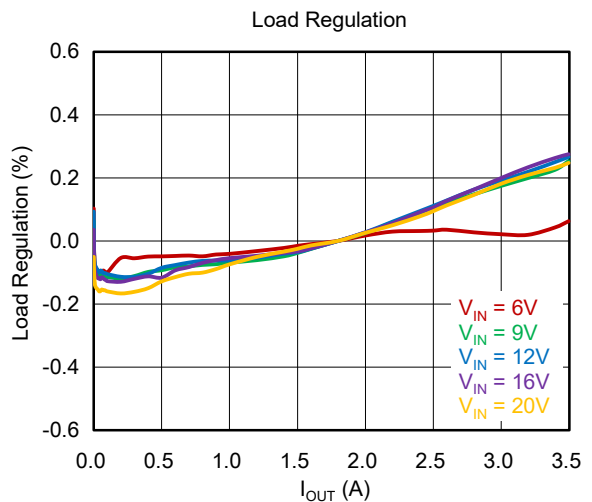
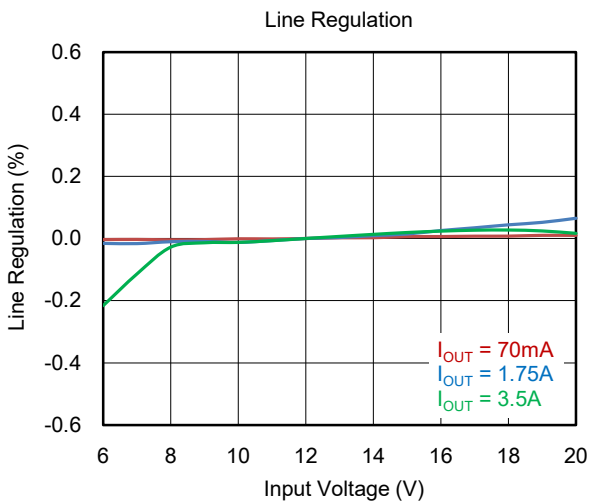
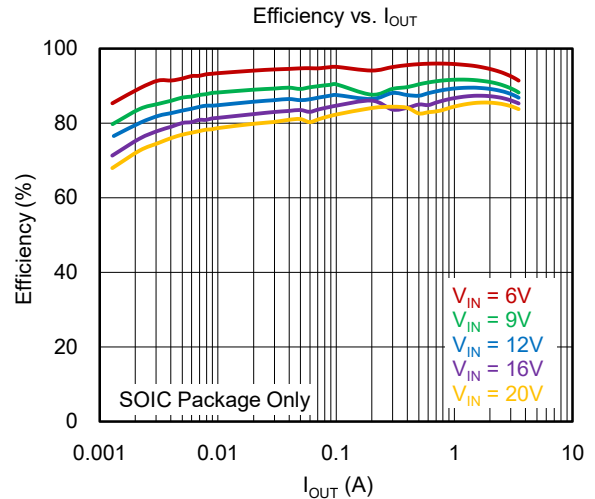
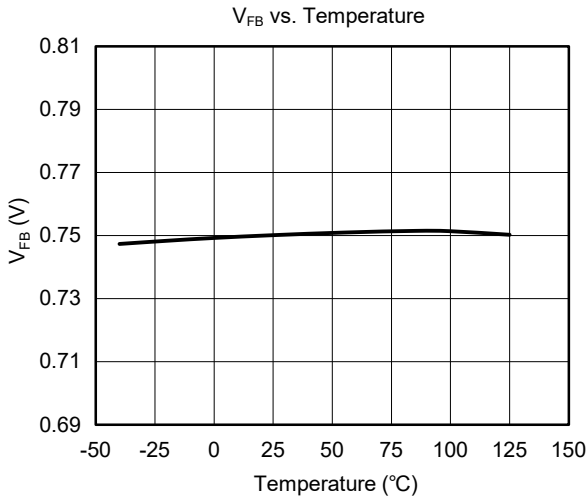
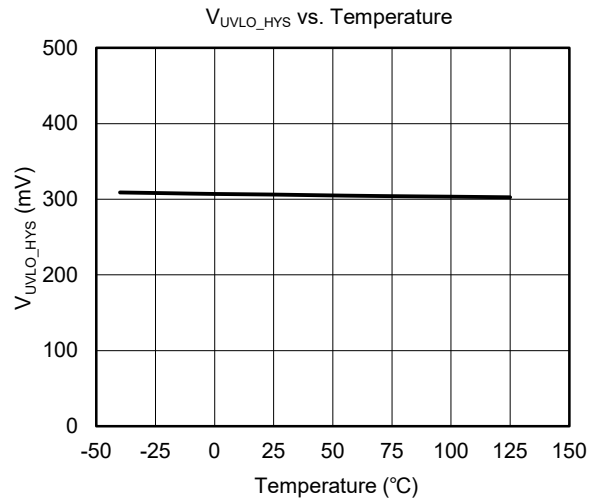
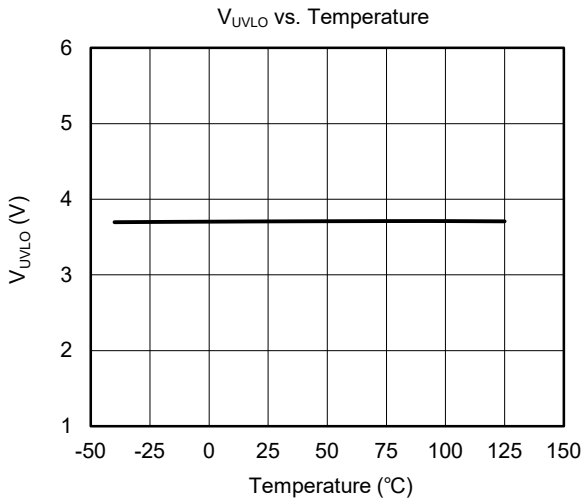

**TYPICAL PERFORMANCE CHARACTERISTICS (continued)**

T<sub>A</sub> = +25°C, V<sub>IN</sub> = 12V, V<sub>OUT</sub> = 5V, f<sub>SW</sub> = 2.1MHz, L = 1.5 $\mu$ H, C<sub>OUT</sub> = 47 $\mu$ F + 10 $\mu$ F, unless otherwise noted.

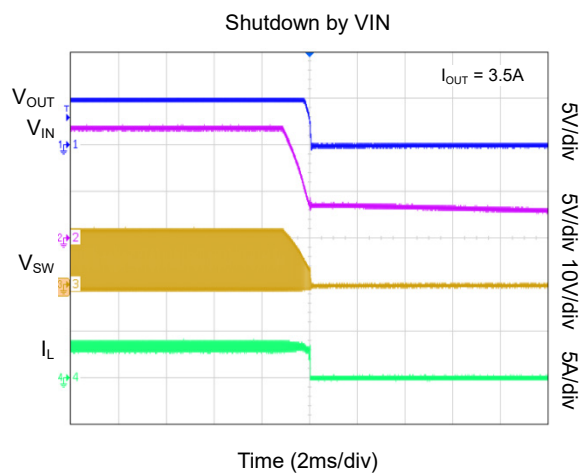
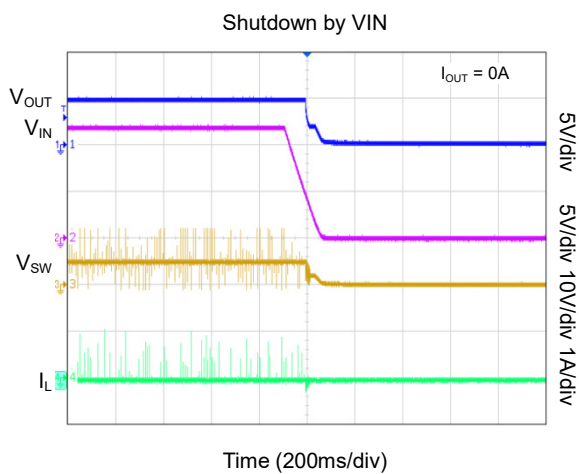
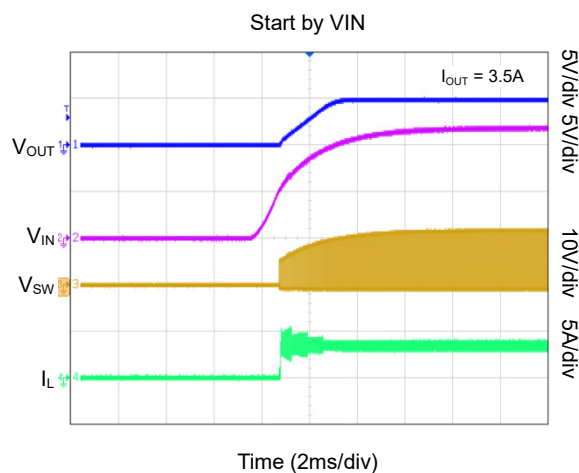
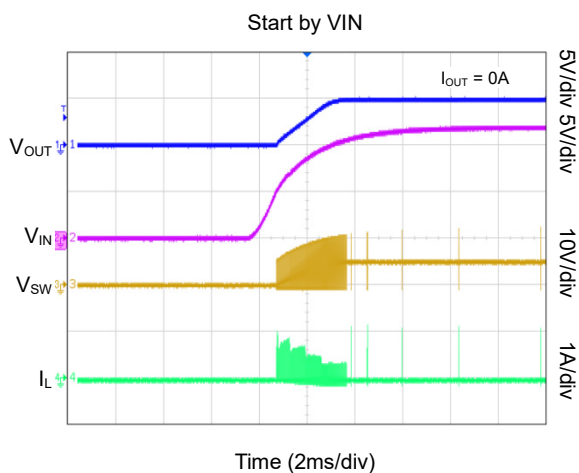
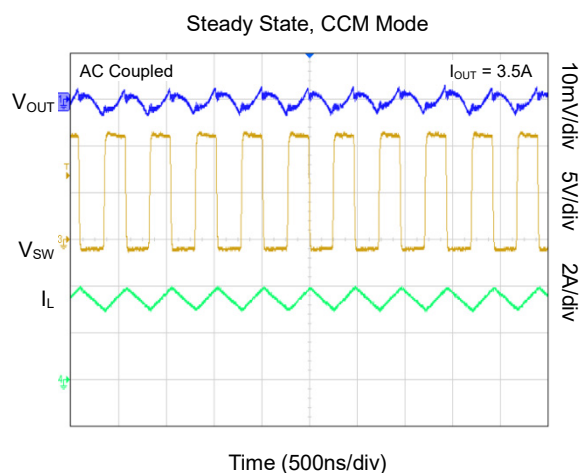
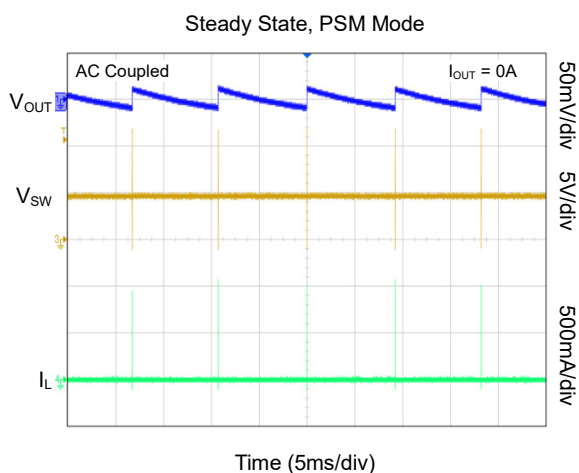

**TYPICAL PERFORMANCE CHARACTERISTICS (continued)**

T<sub>A</sub> = +25°C, V<sub>IN</sub> = 12V, V<sub>OUT</sub> = 5V, f<sub>SW</sub> = 2.1MHz, L = 1.5 $\mu$ H, C<sub>OUT</sub> = 47 $\mu$ F + 10 $\mu$ F, unless otherwise noted.

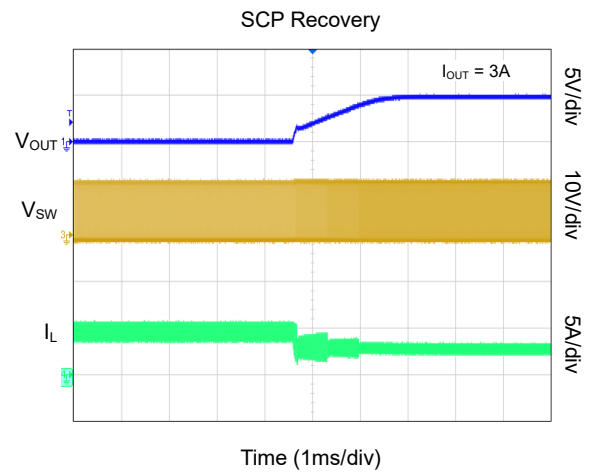
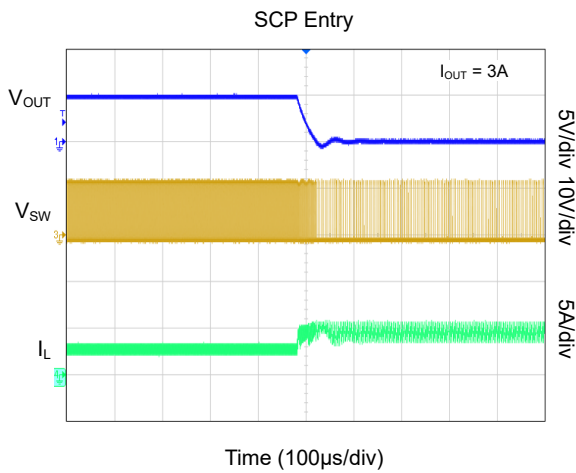
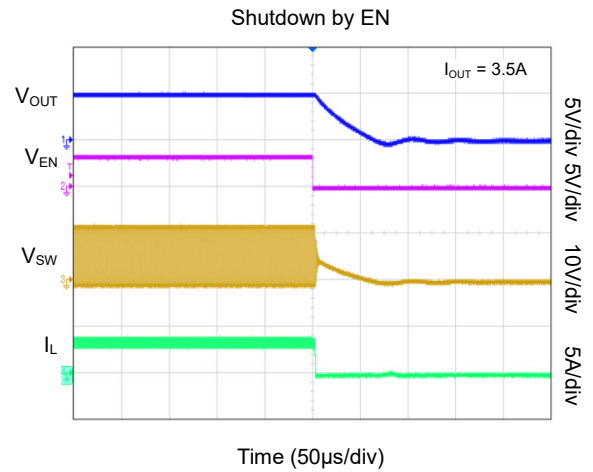
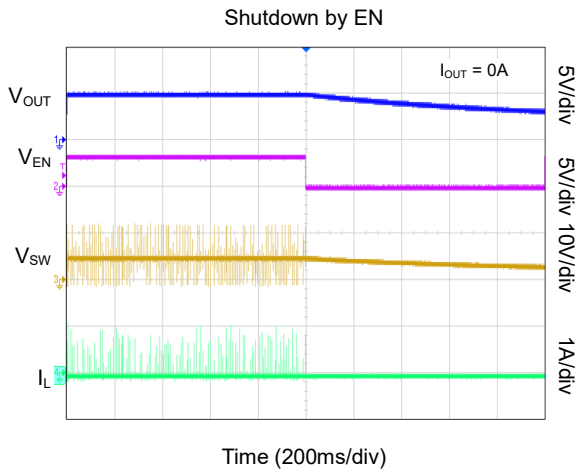
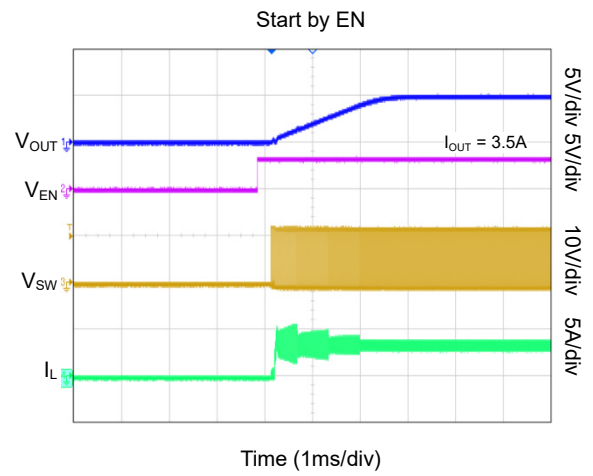
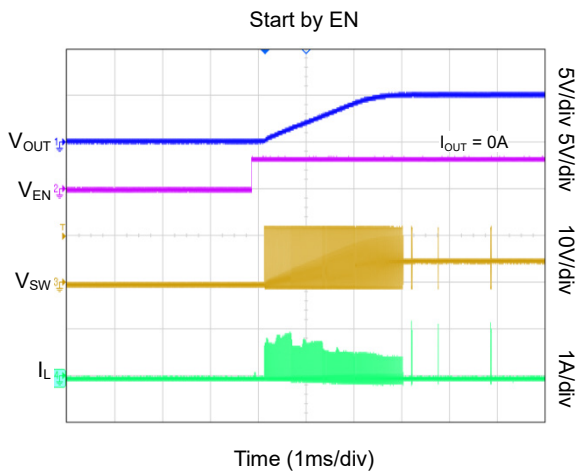

**TYPICAL PERFORMANCE CHARACTERISTICS (continued)**

T<sub>A</sub> = +25°C, V<sub>IN</sub> = 12V, V<sub>OUT</sub> = 5V, f<sub>SW</sub> = 2.1MHz, L = 1.5 $\mu$ H, C<sub>OUT</sub> = 47 $\mu$ F + 10 $\mu$ F, unless otherwise noted.

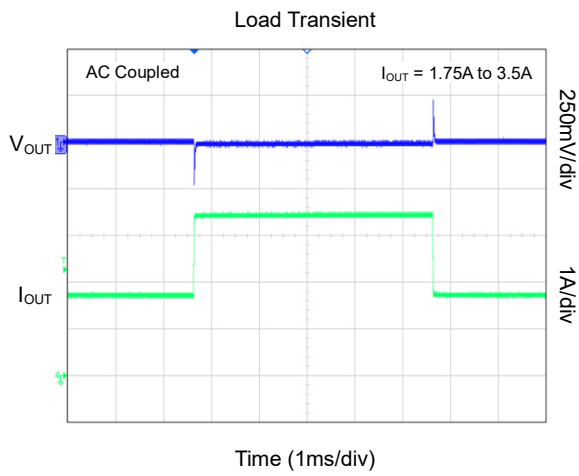

**FUNCTIONAL BLOCK DIAGRAM**

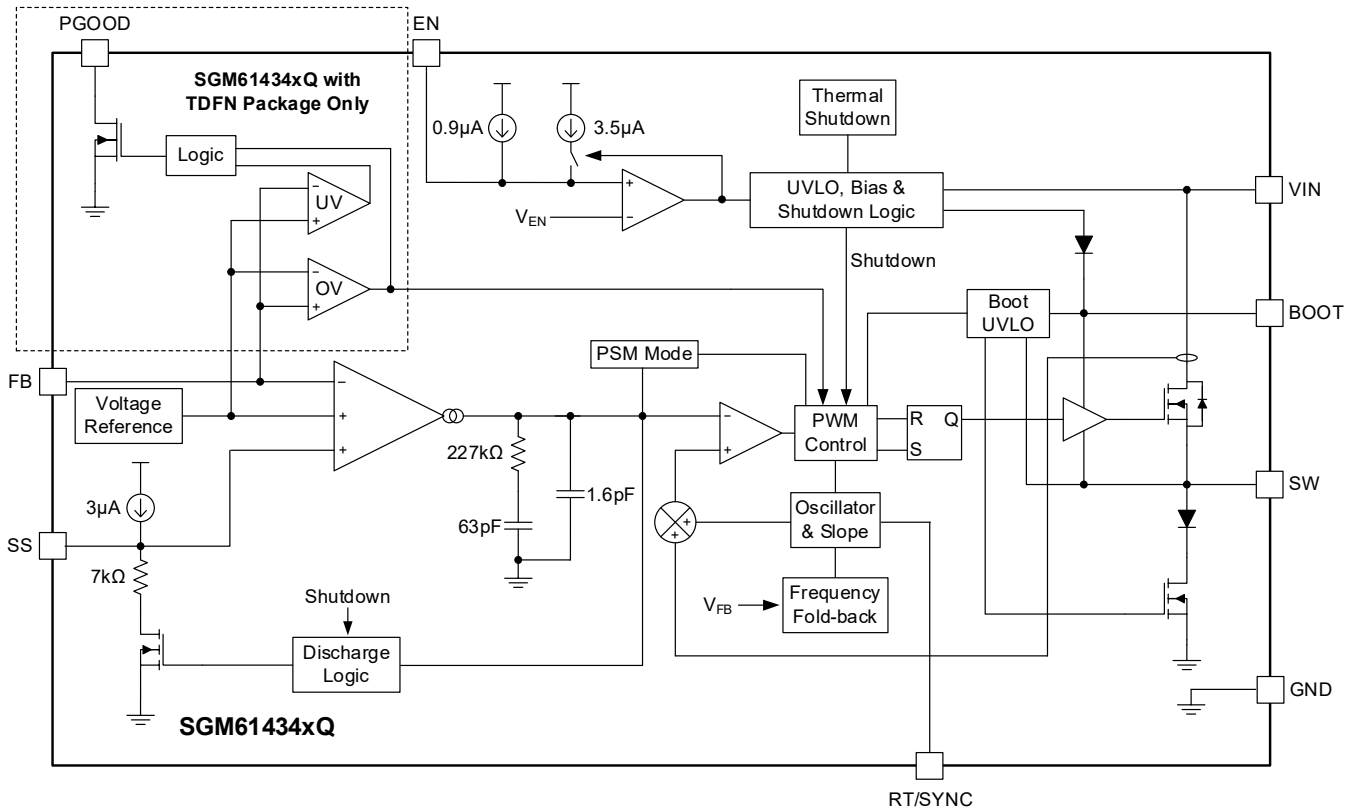

Figure 2. SGM61434xQ Block Diagram

**DETAILED DESCRIPTION**

**Overview**

The SGM61434xQ is a 40V Buck converter with an integrated N-MOSFET power switch and 3.5A continuous output current capability. Using peak current mode control, this device provides good line and load transient responses with reduced output capacitance. Light load efficiency is enhanced by a special power-save mode.

The minimum operating input voltage of the device is 4V and its nominal frequency is 2.1MHz (R<sub>T</sub> = 11kΩ). The quiescent current is 47µA. It reduces to 2.1µA if the device is disabled. The low R<sub>DS(ON)</sub> high-side switch (80mΩ in SOIC package and 90mΩ in TDFN package) allows high operating efficiency.

The EN pin is internally pulled up by a current source that can keep the device enabled if EN is floating. It can also be used to increase the input UVLO threshold using a resistor divider.

The bootstrap diode is integrated and only a small capacitor between BOOT and SW pins (C<sub>BOOT</sub>) is needed for the MOSFET gate driving bias. A separate UVLO circuit monitors C<sub>BOOT</sub> voltage and turns the switch off if this voltage falls below a preset threshold.

The switching frequency is adjusted by using a resistor to ground which is connected to the RT/SYNC pin. It is also can be synchronized to an external clock signal.

The SS pin internal current source allows soft-start time adjustments with a small external capacitor.

During startup and over-current, the frequency is reduced (frequency fold-back) to prevent inductor current from running away.

Additional features such as thermal shutdown, over-voltage protection and short-circuit protection (cycle-by-cycle current limit) are also provided.

**DETAILED DESCRIPTION (continued)**

**Minimum Input Voltage (4V) and UVLO**

The recommended minimum operating input voltage is 4V. It may operate with lower voltages that are above the V<sub>IN</sub> rising UVLO threshold (3.7V TYP). If V<sub>IN</sub> falls below its falling UVLO threshold, the device will stop switching.

**Enable Input and UVLO Adjustment**

An internal current source pull-up keeps the EN pin voltage at high state by default. The device will enable if the EN pin voltage exceeds the enable threshold of 1.2V and V<sub>IN</sub> exceeds its UVLO threshold. The device will disable if the EN voltage is externally pulled low or the VIN pin voltage falls below its UVLO threshold.

If an application requires a higher input UVLO threshold, an external input UVLO adjustment circuit is recommended in Figure 3. Figure 3 shows how UVLO and hysteresis are increased using R<sub>EN1</sub> and R<sub>EN2</sub>. A 3.5μA additional current is injected to the divider when EN pin voltage exceeds V<sub>EN\_TH</sub> (1.2V) to provide hysteresis and it will be removed when EN pin voltage is below V<sub>EN\_TH</sub> - V<sub>EN\_HYS</sub>. Use Equations 1 and 2 to calculate these resistors. V<sub>START</sub> is the input start (turn-on) threshold voltage and V<sub>STOP</sub> is the input stop (turn-off) threshold voltage.

$$R_{EN1} = \frac{V_{START} \left( \frac{V_{EN\_TH} - V_{EN\_HYS}}{V_{EN\_TH}} \right) - V_{STOP}}{3.5\mu A + 0.9\mu A \times \left( 1 - \frac{V_{EN\_TH} - V_{EN\_HYS}}{V_{EN\_TH}} \right)} \quad (1)$$

$$R_{EN2} = \frac{V_{EN\_TH} \times R_{EN1}}{0.9\mu A \times R_{EN1} + V_{START} - V_{EN\_TH}} \quad (2)$$

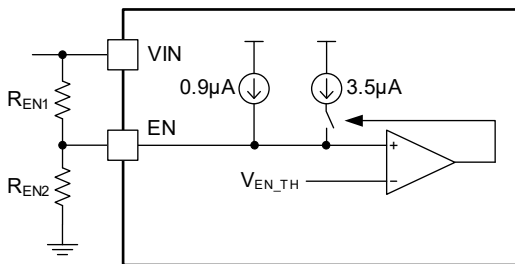

**Figure 3. Input UVLO Adjustment**

**Low Dropout Operation and Bootstrap Gate Driving (BOOT Pin)**

An internal regulator provides the bias voltage for gate driver using a 0.1μF ceramic capacitor. X5R or better dielectric types are recommended. The capacitor must have a 10V or higher voltage rating.

The SGM61434xQ operates at maximum duty cycle when input voltage is closed to output voltage as long as the bootstrap voltage (V<sub>BOOT</sub> - V<sub>SW</sub>) is greater than its UVLO threshold. When the bootstrap voltage falls below its UVLO, the high-side switch is turned off, and the integrated low-side switch is turned on to recharge the BOOT capacitor. After the recharge, the high-side switch is turned on again to regulate the output.

**SS Pin and Soft-Start Adjustment**

It is recommended to add a soft-start capacitor (C<sub>SS</sub>) between the SS and GND pins to set the soft-start time from 1ms to 10ms for a proper startup. The lower of the SS pin voltage V<sub>SS</sub> and V<sub>REF</sub> is applied to the error amplifier to regulate the output. The internal I<sub>SS</sub> = 3μA current charges C<sub>SS</sub> and provides a linear voltage ramp on the SS pin. Use Equation 3 to calculate the soft-start time.

$$t_{SS} \text{ (ms)} = \frac{C_{SS} \text{ (nF)} \times V_{REF} \text{ (V)}}{I_{SS} \text{ (}\mu\text{A)}} \quad (3)$$

**DETAILED DESCRIPTION (continued)**

**Slope Compensation**

Without implementing some slope compensation, the PWM pulse widths will be unstable and oscillatory at duty cycles above 50%. To avoid sub-harmonic oscillations in this device, an internal compensation ramp is added to the measured switch current before comparing it with the control signal by the PWM comparator.

**Power-Save Mode**

At light loads, the SGM61434xQ enters pulse-skipping power-save mode (PSM) to keep its high efficiency by lowering the number of switching pulses. When the EA output voltage (V<sub>COMP</sub>) is lower than the internal PSM threshold. The device will enter PSM in such conditions.

After entering PSM for a delay time, some modules are shut down to minimum input current, and the device draws only 47μA (TYP) input quiescent current. The device can exit PSM if V<sub>COMP</sub> rises above the internal PSM threshold. During PSM operation, the actual load current (DC) threshold for PSM will depend on the output filter.

**Synchronization to RT/SYNC Pin**

The internal oscillator can synchronize to an external logic clock applied to the RT/SYNC pin (see Figure 4) in the 250kHz to 2300kHz range. The SW rising edge (switch turn-on) is synchronized with the CLK falling edge. The CLK low level must be less than 0.5V (TYP), and high level must be more than 1.7V (TYP) and have a pulse width larger than 30ns. So, when the CLK source is off, the DC resistance (R<sub>T</sub>) between RT/SYNC and GND pins determines the default switching frequency.

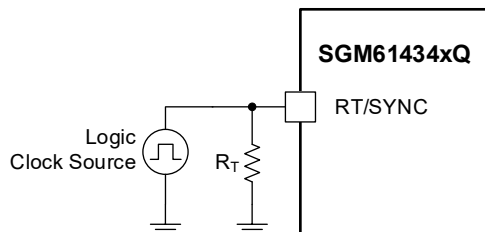

**Figure 4. Synchronization to External Clock**

**Switching Frequency and Timing Resistor (RT/SYNC Pin)**

The switching frequency can be set from 200kHz to 2500kHz by a timing resistor (R<sub>T</sub>) placed between the RT/SYNC and GND pins. There is an internal bias voltage on the RT/SYNC pin during the RT mode and must have a resistor to ground to set the switching frequency. Use Equation 4 to find the R<sub>T</sub> resistance for any desired switching frequency (f<sub>sw</sub>).

$$R_T \text{ (k}\Omega\text{)} = \frac{31928}{f_{sw} \text{ (kHz)}^{1.042}} \tag{4}$$

**Power Good (PGOOD)**

The SGM61434xQ with TDFN package has a power good (PGOOD) pin for indicating the output voltage in the desired level. Connect to suitable voltage supply through a pull-up resistor. It can be left open when not used.

As shown in Figure 5, when the FB voltage is within the power good range, the PGOOD switch is turned off and the PGOOD pin is pulled up to high. When the FB voltage is outside the power good range, the PGOOD switch is turned on and the PGOOD pin is pulled down to low.

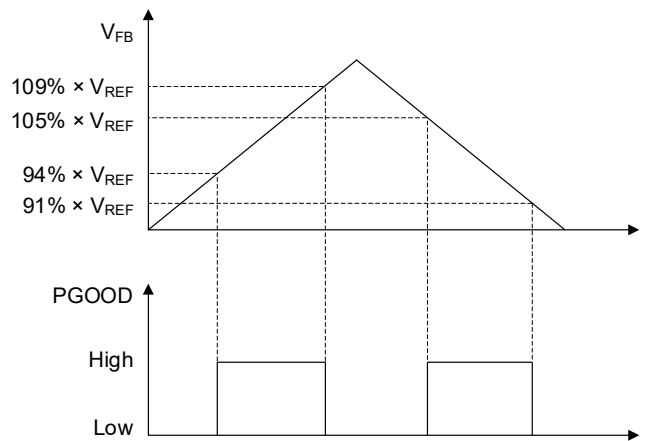

**Figure 5. PGOOD Flag**

## **DETAILED DESCRIPTION (continued)**

### **Over-Current Protection and Frequency Fold-back**

Over-current protection (OCP) is naturally provided by current mode control. In each cycle, the high-side current sensing starts a short time (blanking time) after the high-side switch is turned on. The sensed high-side switch current is continuously compared with the EA output ( $V_{COMP}$ ) when the high-side current reaches to that threshold, the high-side switch is turned off. If the output is overload, the peak current of high-side switch is limited by a maximum peak current  $I_{LIM}$ .

In the SGM61434xQ, there is frequency fold-back function, which can prevent inductor current from running away.

In a short or overload condition, if the peak current limit is triggered 6 times consecutively, the switching frequency will be divided by 2 immediately, as the FB voltage drops, the frequency will be divided by 4 ( $V_{FB} = 0.4V$ ) and 8 ( $V_{FB} = 0.2V$ ). In conclusion, if the sensed high-side switch current reached to peak current-limit  $I_{LIM}$ , the HS is turned off, the HS switch is turned on at the next clock. On the contrary, when the output short-circuit is removed or  $V_{IN}$  startup, the switching

frequency increase with the FB voltage at  $V_{FB} = 0.2V$ ,  $0.4V$ ,  $0.6V$  respectively. Finally the SGM61434xQ working at the switching frequency set by  $R_T$ .

### **Over-Voltage Transient Protection**

The SGM61434xQ includes over-voltage protection (OVP) circuit to reduce such over-voltage transients. If  $V_{FB}$  voltage exceeds 109% of the  $V_{REF}$  threshold, the MOSFET is turned off. When it returns below 105% of the  $V_{REF}$  threshold, the MOSFET is released again.

### **Spread Spectrum Switching (SGM61434BQ Only)**

Spread spectrum technique is used in the SGM61434BQ to flatten the generated EMI spectrum and reduce the large EMI peaks. The switching frequency is periodically varied between -6% and +6% of the nominal value.

### **Thermal Shutdown (TSD)**

If the junction temperature ( $T_J$ ) exceeds  $+173^{\circ}C$ , the TSD protection circuit will stop switching to protect the device from overheating. The device will automatically restart with a power up sequence when the junction temperature drops below  $+158^{\circ}C$ .

**APPLICATION INFORMATION**

A typical application circuit for the SGM61434xQ as a Buck converter is shown in Figure 6. It is used for converting a 7V to 40V supply voltage to a lower voltage level supply voltage (5V) suitable for the system.

The external components are designed based on the application requirements and device stability. Some suitable parameters for different output voltages are provided in Table 1 to simplify the selection of components. The C<sub>OUT</sub> values in Table 1 are recommended capacitance values for use, which have considered aging, temperature, and DC bias derating of the output capacitors.

**Typical Application**

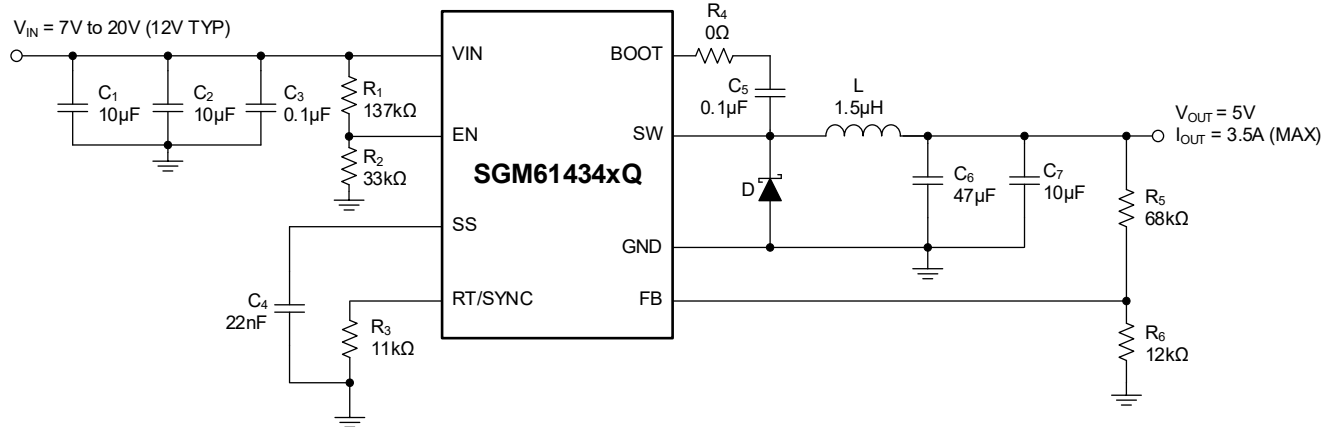

**Figure 6. 5V Output SGM61434xQ Design Example**

**Table 1. Some Typical L and C<sub>OUT</sub> Values for Stable Operation**

f <sub>sw</sub> (kHz)	V <sub>OUT</sub> (V)	L (µH)	C <sub>OUT</sub> (µF) <sup>(1)</sup>	R <sub>5</sub> (kΩ)	R <sub>6</sub> (kΩ)
2100	3.3	1.2	47µF × 2 (25V)	68	20
2100	5	1.5	47µF + 10µF (25V)	68	12
2100	12	3.3	22µF × 2 (25V)	150	10
400	5	8.2	47µF × 3 (25V)	68	12
400	12	15	47µF × 2 + 22µF (25V)	150	10

NOTE:

1. Ceramic capacitor is used in this table.

**Design Requirements**

The design parameters given in Table 2 are used for this design example.

**Table 2. Design Parameters**

Design Parameters	Example Values
Input Voltage	12V (TYP) 7V to 20V
Start Input Voltage (Rising V <sub>IN</sub> )	6.5V
Stop Input Voltage (Falling V <sub>IN</sub> )	5.5V
Output Voltage	5V
Output Voltage Ripple	50mV, 1% of V <sub>OUT</sub>
Output Current Rating	3.5A
Transient Response 1.75A to 3.5A Load Step	250mV, 5% of V <sub>OUT</sub>
Operation Frequency	2100kHz

**Switching Frequency Selection**

Several parameters such as losses, inductor and capacitors sizes and response time are considered in selection of the switching frequency. Higher frequency increases the switching and gate charge losses, and lower frequency requires larger inductance and capacitances, which results in larger overall physical size and higher cost. Therefore, a tradeoff is needed between losses and component size. If the application is noise-sensitive to a frequency range, the frequency should be selected out of that range.

For this design, a switching frequency of 2100kHz is chosen and a 11kΩ resistor can be chosen for R<sub>3</sub> according to Equation 4.

**APPLICATION INFORMATION (continued)**

**Input Capacitor Design**

High frequency decoupling on the input supply pins is necessary for the device. A bulk capacitor may also be needed in some applications. Typically, 10μF to 22μF high quality ceramic capacitor (X5R, X7R or better) with voltage rating twice the maximum input voltage is recommended for decoupling capacitor. If the source is away from the device (> 5cm) some bulk capacitance is also needed to damp the voltage spikes caused by the wiring or PCB trace parasitic inductances. For this design, a ceramic capacitor with at least 50V voltage rating is required to support the maximum input voltage. Therefore, 2×10μF/50V/X7R capacitors and a 0.1μF ceramic capacitor placed right beside the device VIN and GND pins for very high-frequency filtering are used. This ripple can be calculated from Equation 5.

$$\Delta V_{IN} = \frac{I_{OUT} \times D \times (1-D)}{C_{IN} \times f_{SW}} + I_{OUT} \times ESR_{CIN} \quad (5)$$

**Inductor Design**

Equation 6 is conventionally used to calculate the inductance of a Buck converter. Generally, a smaller inductor is preferred to allow larger bandwidth and smaller size. The ratio of inductor current ripple ( $\Delta I_L$ ) to the maximum output current ( $I_{OUT}$ ) is represented as  $K_{IND}$  factor ( $\Delta I_L/I_{OUT}$ ). The inductor ripple current is bypassed and filtered by the output capacitor and the inductor DC current is passed to the output. Inductor ripple is selected based on a few considerations. The peak inductor current ( $I_{OUT} + \Delta I_L/2$ ) must have a safe margin from the saturation current of the inductor in the worst-case conditions, especially if a hard-saturation core type inductor (such as ferrite) is chosen. For peak current mode converter, selecting an inductor with saturation current above the switch current limit is sufficient. The ripple current also affects the selection of the output capacitor.  $C_{OUT}$  RMS current rating must be higher than the inductor RMS ripple. Typically, a 20% to 40% ripple is selected ( $K_{IND} = 0.2 \sim 0.4$ ). Choosing a higher  $K_{IND}$  value reduces the selected inductance, however, a too high  $K_{IND}$  factor may result in insufficient slope compensation.

$$L = \frac{V_{IN\_MAX} - V_{OUT}}{I_{OUT} \times K_{IND}} \times \frac{V_{OUT}}{V_{IN\_MAX} \times f_{SW}} \quad (6)$$

In this example, the calculated inductance will be 1.49μH with  $K_{IND} = 0.4$ , so the nearest larger inductance of 1.5μH is selected. The ripple, RMS and peak inductor current calculations are summarized in Equations 7, 8 and 9 respectively.

$$\Delta I_L = \frac{V_{IN\_MAX} - V_{OUT}}{L} \times \frac{V_{OUT}}{V_{IN\_MAX} \times f_{SW}} \quad (7)$$

$$I_{L\_RMS} = \sqrt{I_{OUT}^2 + \frac{\Delta I_L^2}{12}} \quad (8)$$

$$I_{L\_PEAK} = I_{OUT} + \frac{\Delta I_L}{2} \quad (9)$$

Note that during startup, load transients or under fault conditions, the peak inductor current may exceed the calculated  $I_{L\_PEAK}$ . Therefore, it is always safer to choose the inductor saturation current higher than the switch current limit.

**External Diode**

An external power diode between the SW and GND pins is needed for the SGM61434xQ. This diode must tolerate the application's absolute maximum ratings. The reverse blocking voltage must be higher than  $V_{IN\_MAX}$  and its peak current must be above the maximum inductor current. Choose a diode with small forward voltage drop for higher efficiency. Typically, diodes with higher voltage and current ratings have higher forward voltages. A diode with a minimum of 50V reverse voltage is preferred to allow input voltage transients up to the rated voltage of the SGM61434xQ.

**Output Capacitor**

Two primary criteria must be considered for design of the output capacitor ( $C_{OUT}$ ):

1. The output voltage ripple.
2. The transient response to a large change in load current.

**APPLICATION INFORMATION (continued)**

For load transient, typically, it requires several cycles for the loop to detect the output change and respond (change the duty cycle). Equation 10 can be used to calculate the minimum output capacitance that is needed to supply a current step ( $\Delta I_{OUT}$ ) for at least 8 cycles ( $f_{SW} = 2.1\text{MHz}$ ) until the control loop responds to the load change with a maximum allowed output transient of  $\Delta V_{OUT}$  (overshoot or undershoot).

$$C_{OUT} > \frac{8 \times \Delta I_{OUT}}{f_{SW} \times \Delta V_{OUT}} \quad (10)$$

where:

$\Delta I_{OUT}$  is the change in output current.

$\Delta V_{OUT}$  is the allowable change in the output voltage.

For example, if the acceptable transient from 1.75A to 3.5A load step is 5%, by inserting  $\Delta V_{OUT} = 0.05 \times 5V = 0.25V$  and  $\Delta I_{OUT} = 1.75A$ , the minimum required capacitance will be  $26.7\mu F$ . Note that the impact of output capacitor ESR on the transient is not taken into account in Equation 10. For ceramic capacitors, the ESR is generally small enough to ignore its impact on the calculation of  $\Delta V_{OUT}$  transient. However, for aluminum electrolytic and tantalum capacitors, or high current power supplies, the ESR contribution to  $\Delta V_{OUT}$  must be considered.

When the load steps down, the excess inductor current will charge the capacitor and the output voltage will overshoot. So  $C_{OUT}$  must be large enough as given in Equation 11 to absorb the excess inductor energy with limited over-voltage. Equation 11 calculates the minimum capacitance required to keep the output-voltage overshoot to a desired value.

$$C_{OUT} > L \times \frac{I_{OUT\_H}^2 - I_{OUT\_L}^2}{(V_{OUT} + \Delta V_{OUT})^2 - V_{OUT}^2} \quad (11)$$

where:

$I_{OUT\_H}$  is the high level of the current step.

$I_{OUT\_L}$  is the low level of the current step.

For example, if the acceptable transient from 3.5A to 1.75A load step is 5%, by inserting  $\Delta V_{OUT} = 0.05 \times 5V = 0.25V$ , the minimum required capacitance will be  $5.4\mu F$ .

Equation 12 can be used for the output voltage ripple criteria and finding the minimum output capacitance needed.  $V_{OUT\_RIPPLE}$  is the maximum acceptable ripple.

$$C_{OUT} > \frac{\Delta I_L}{8 \times f_{SW} \times V_{OUT\_RIPPLE}} \quad (12)$$

Note that the impact of output capacitor ESR on the ripple is not considered in Equation 12. For a specific output capacitance value, use Equation 13 to calculate the maximum acceptable ESR of the output capacitor to meet the output voltage ripple requirement.

$$ESR_{C_{OUT}} < \frac{V_{OUT\_RIPPLE}}{\Delta I_L} - \frac{1}{8 \times f_{SW} \times C_{OUT}} \quad (13)$$

Higher nominal capacitance value must be chosen due to aging, temperature, and DC bias derating of the output capacitors. In this example,  $2 \times 47\mu F/25V$  X5R ceramic capacitors with  $1.5m\Omega$  of ESR are used. The amount of ripple current that a capacitor can handle without damage or overheating is limited. The inductor ripple is bypassed through the output capacitor. Equation 14 calculates the RMS current that the output capacitor must support. In this example, it is  $344mA$ .

$$I_{C_{OUT\_RMS}} = \frac{V_{OUT} \times (V_{IN\_MAX} - V_{OUT})}{\sqrt{12} \times V_{IN\_MAX} \times L \times f_{SW}} \quad (14)$$

**Bootstrap Capacitor Selection**

Use a  $0.1\mu F$  high-quality ceramic capacitor (X7R or X5R) with 10V or higher voltage rating for the bootstrap capacitor ( $C_5$ ). A  $5\Omega$  to  $10\Omega$  resistor ( $R_4$ ) can be added in series with  $C_5$  to slow down switch-on speed of the high-side switch and reduce EMI if needed. Too high values for  $R_4$  may cause insufficient  $C_5$  charging in high duty-cycle applications. Slower switch-on speed will also increase switch losses and decrease efficiency.

**APPLICATION INFORMATION (continued)**

**UVLO Setting**

The Input UVLO can be programmed using an external voltage divider on the EN pin of the SGM61434xQ. In this design R<sub>1</sub> is connected between VIN pin and EN pin and R<sub>2</sub> is connected between EN pin and GND (see Figure 6). The UVLO has two thresholds, one for power-up (turn-on) when the input voltage is rising and one for power-down (turn-off) when the voltage is falling. In this design, the turn-on (enable to start switching) occurs when V<sub>IN</sub> rises above 6.5V (UVLO rising threshold). When the regulator is working, it will not stop switching (disabled) until the input falls below 5.5V (UVLO falling threshold). Equations 1 and 2 are provided to calculate the resistors. For this example, the nearest standard resistor values are R<sub>1</sub> = 137kΩ and R<sub>2</sub> = 33kΩ.

**Feedback Resistors Setting**

Use an external resistor divider (R<sub>5</sub> and R<sub>6</sub>) to set the output voltage using Equations 15 and 16.

$$R_5 = R_6 \times \left( \frac{V_{OUT} - V_{REF}}{V_{REF}} \right) \tag{15}$$

$$V_{OUT} = V_{REF} \times \left( \frac{R_5}{R_6} + 1 \right) \tag{16}$$

For 5V output voltage, the selected values are R<sub>5</sub> = 68kΩ, R<sub>6</sub> = 12kΩ.

**Layout Considerations**

PCB is an essential element of any switching power supply. The converter operation can be significantly disturbed due to the existence of the large and fast rising/falling voltages that can couple through stray capacitances to other signal paths, and also due to the large and fast changing currents that can interact through parasitic magnetic couplings, unless those interferences are minimized and properly managed in the layout design. Insufficient conductance in copper traces for the high current paths results in high resistive losses in the power paths and voltage errors. Following the guidelines provided here are necessary to design a good layout:

- Bypass the VIN pin to GND pin (where it connects to the anode pin of the power diode) with low-ESR ceramic capacitors (X5R/X7R or better) and place them as close as possible.
- Minimize the area and path length of the loop formed by VIN pin, bypass capacitors connections, SW pin and the catch diode.

- Connect the device GND pin directly to the exposed pad (Power Pad) copper area under the IC device.
- Connect the exposed pad to the internal ground planes and the back side of the PCB directly under the IC using multiple thermal vias.
- Use a short and wide path for routing the SW pin to the cathode of the catch diode on the same layer and to the output inductor.
- Keep the SW area minimal and away from sensitive signals like FB trace and divider resistors or RT/SYNC to avoid capacitive noise coupling.
- Top side GND plane that is connected to the exposed pad provides the best heat dissipation path for the IC. It should be large enough for designs that operate with full rated loads. Thicker copper planes can improve heat dissipation.
- Place the RT resistor (R<sub>3</sub>) as close as possible to the RT/SYNC pin with short routes.
- Connect the diode as close as possible to SW and GND pins.

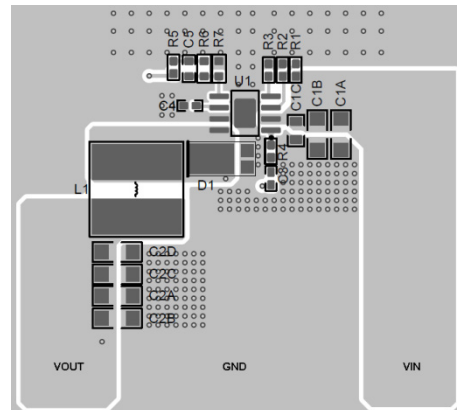

**Figure 7. Top Layer**

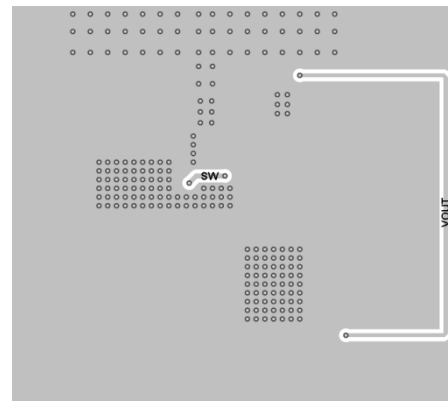

**Figure 8. Bottom Layer**

---

## REVISION HISTORY

NOTE: Page numbers for previous revisions may differ from page numbers in the current version.

<b>JUNE 2026 – REV.A to REV.A.1</b>	<b>Page</b>
Updated Application Information.....	16

---

<b>Changes from Original to REV.A (APRIL 2025)</b>	<b>Page</b>
Changed from product preview to production data.....	All

---

# PACKAGE INFORMATION

## PACKAGE OUTLINE DIMENSIONS

### SOIC-8 (Exposed Pad)

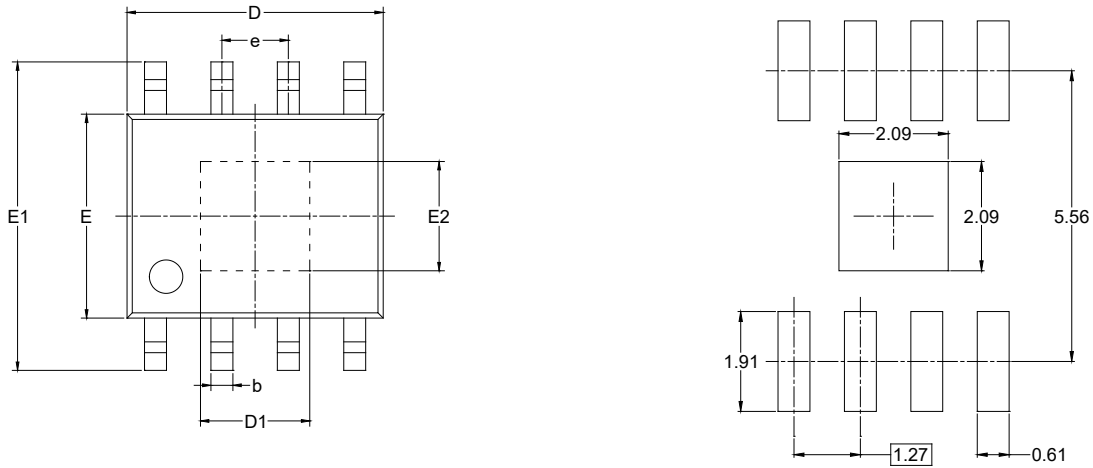

RECOMMENDED LAND PATTERN (Unit: mm)

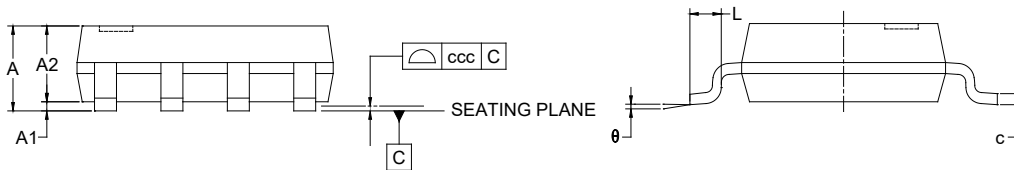

Symbol	Dimensions In Millimeters		
	MIN	NOM	MAX
A			1.700
A1	0.000	-	0.150
A2	1.250	-	1.650
b	0.330	-	0.510
c	0.170	-	0.250
D	4.700	-	5.100
D1	1.890	-	2.290
E	3.800	-	4.000
E1	5.800	-	6.200
E2	1.890	-	2.290
e	1.27 BSC		
L	0.400	-	1.270
$\theta$	0°	-	8°
ccc	0.100		

**NOTES:**

1. This drawing is subject to change without notice.
2. The dimensions do not include mold flashes, protrusions or gate burrs.
3. Reference JEDEC MS-012.

# PACKAGE INFORMATION

## PACKAGE OUTLINE DIMENSIONS

### TDFN-4x4-10AL

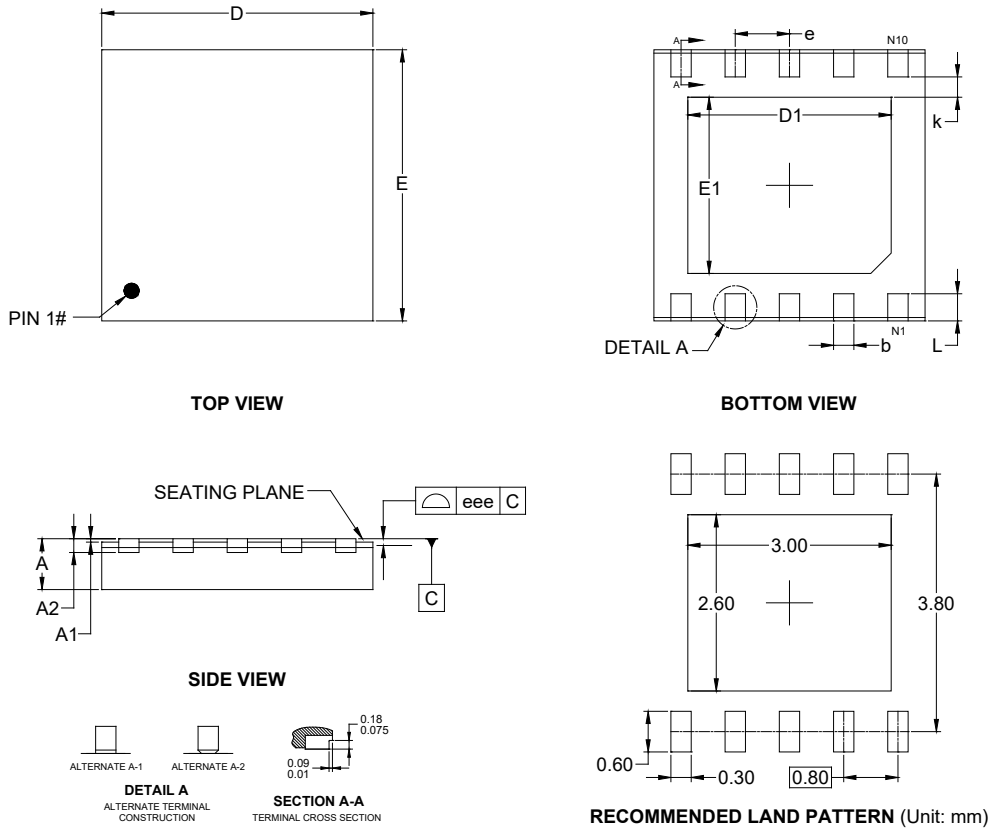

Symbol	Dimensions In Millimeters		
	MIN	NOM	MAX
A	0.700	-	0.800
A1	0.000	-	0.050
A2	0.203 REF		
b	0.250	-	0.350
D	3.900	-	4.100
D1	2.900	-	3.100
E	3.900	-	4.100
E1	2.500	-	2.700
e	0.800 BSC		
k	0.300 REF		
L	0.300	-	0.500
eee	0.080		

NOTE: This drawing is subject to change without notice.

**TAPE AND REEL INFORMATION**

**REEL DIMENSIONS**

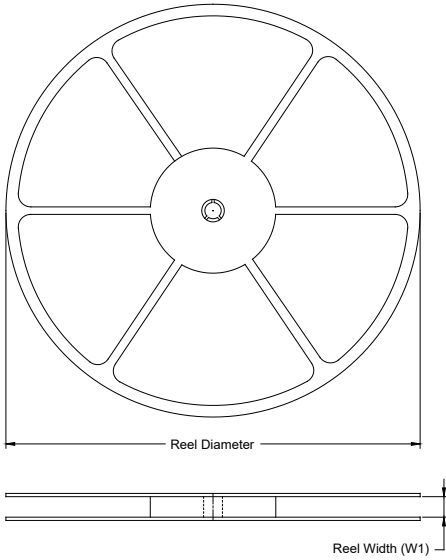

**TAPE DIMENSIONS**

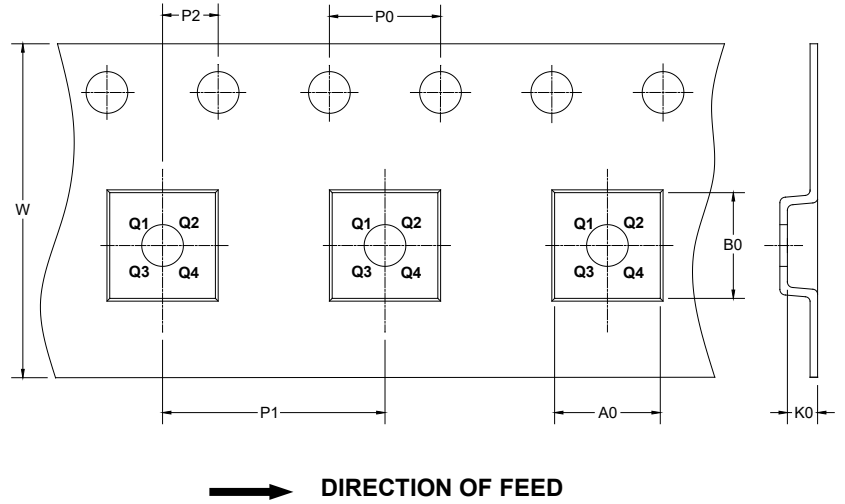

NOTE: The picture is only for reference. Please make the object as the standard.

**KEY PARAMETER LIST OF TAPE AND REEL**

Package Type	Reel Diameter	Reel Width W1 (mm)	A0 (mm)	B0 (mm)	K0 (mm)	P0 (mm)	P1 (mm)	P2 (mm)	W (mm)	Pin1 Quadrant
SOIC-8 (Exposed Pad)	13"	12.4	6.40	5.40	2.10	4.0	4.0	2.0	12.0	Q1
TDFN-4x4-10AL	13"	12.4	4.30	4.30	1.10	4.0	8.0	2.0	12.0	Q2

D200001

# PACKAGE INFORMATION

## CARTON BOX DIMENSIONS

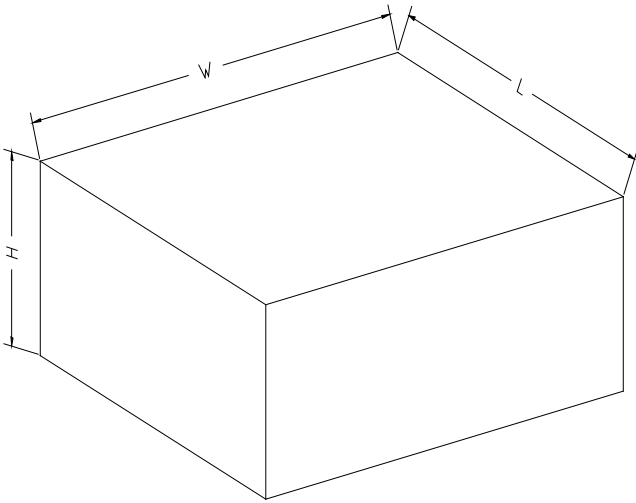

NOTE: The picture is only for reference. Please make the object as the standard.

## KEY PARAMETER LIST OF CARTON BOX

Reel Type	Length (mm)	Width (mm)	Height (mm)	Pizza/Carton
13"	386	280	370	5

DD0002