

### GENERAL DESCRIPTION

The SGM90800A is an analog front end (AFE) designed for precise digital power monitor with an I<sup>2</sup>C or SMBus-compatible digital interface. The device provides bus supply voltage, shunt voltage and internal temperature monitor. The internal high resolution ADC, with flexible configurations including calibration value, conversion times as well as average numbers support direct fetch of current values in amperes and power values in watts.

The SGM90800A can measure a differential input voltage of  $\pm 163.84\text{mV}$  with common-mode voltage from 0V to 120V while the shunt voltage measurement pins IN+ and IN- can survive under a wide common voltage from -10V to 120V. The bus voltage measurement supports the range from 0V to 120V or 0V to 85V. The integrated temperature sensor has  $\pm 1^\circ\text{C}$  (TYP) accuracy for die temperature measurement, which is useful in the system level temperature calibrations.

With low offset and drift design of the SGM90800A, it is suitable for applications under wide range of temperature variation and simplifies the calibration. These features also make the device suitable for precise sensing systems. Two shunt voltage input ranges help expand the current measurement range.

The SGM90800A is available in a Green MSOP-10 package.

### FEATURES

- **High Accuracy and High Resolution:**
  - True 16-Bit Sigma-Delta ( $\Sigma$ - $\Delta$ ) ADC
  - Gain Error:  $\pm 0.4\%$  (MAX)
  - Offset:  $\pm 32\mu\text{V}$  (MAX)
  - Common Mode Rejection: 120dB (MIN)
  - Input Bias Current: 3nA (MAX)
- **Two Shunt Voltage Measurement Ranges:**  $\pm 163.84\text{mV}$  and  $\pm 40.96\text{mV}$
- **Two Bus Voltage Measurement Ranges:** 0V to 85V and 0V to 120V
- **3.4MHz High-Speed I<sup>2</sup>C Interface with 16 Pin-Selectable Addresses**
- **Available in a Green MSOP-10 Package**

### APPLICATIONS

- Enterprise Servers
- Telecom Equipment
- Storage Battery Charging and Discharging
- Power Managements
- Test Equipment

### TYPICAL APPLICATION

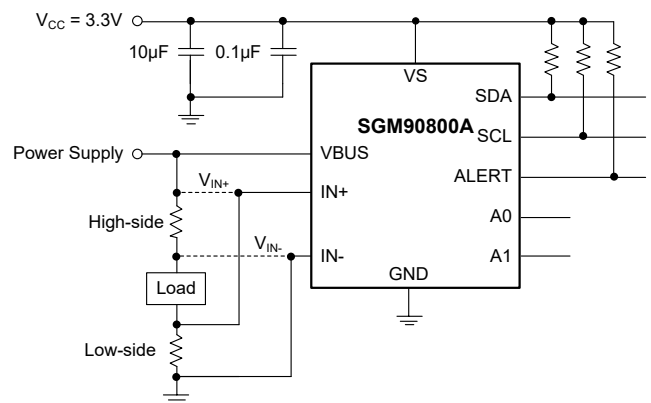

Figure 1. High-side/Low-side Sensing Application Circuit

**PACKAGE/ORDERING INFORMATION**

MODEL	PACKAGE DESCRIPTION	SPECIFIED TEMPERATURE RANGE	ORDERING NUMBER	PACKAGE MARKING	PACKING OPTION
SGM90800A	MSOP-10	-40°C to +125°C	SGM90800AXMS10G/TR	SGM2L4 XMS10 XXXXXX	Tape and Reel, 4000
			SGM90800AXMS10SG/TR	SGM2L4 XMS10 XXXXXX	Tape and Reel, 500

**MARKING INFORMATION**

NOTE: XXXXX = Date Code, Trace Code and Vendor Code.

**XXXXX**

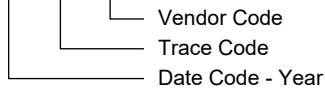

Green (RoHS & HSF): SG Micro Corp defines "Green" to mean Pb-Free (RoHS compatible) and free of halogen substances. If you have additional comments or questions, please contact your SGMICRO representative directly.

**ABSOLUTE MAXIMUM RATINGS**

Supply Voltage, V <sub>S</sub> .....	6V
Analog Inputs, I <sub>N+</sub> , I <sub>N-</sub>	
Differential (V <sub>IN+</sub> - V <sub>IN-</sub> ) .....	-40V to 40V
Common Mode (V <sub>IN+</sub> + V <sub>IN-</sub> )/2 .....	-10V to 125V
VBUS Voltage, V <sub>VBUS</sub> .....	-0.3V to 125V
ALERT Voltage, V <sub>ALERT</sub> .....	-0.3V to V <sub>S</sub> + 0.3V
SDA, SCL Voltage, V <sub>SDA</sub> , V <sub>SCL</sub> .....	- 0.3V to 6V
Input Current into Any Pin, I <sub>IN</sub> .....	5mA
Digital Output Current, I <sub>OUT</sub> .....	10mA
Package Thermal Resistance	
MSOP-10, θ <sub>JA</sub> .....	128.1°C/W
MSOP-10, θ <sub>JB</sub> .....	73.4°C/W
MSOP-10, θ <sub>JC</sub> .....	37.9°C/W
Junction Temperature.....	+150°C
Storage Temperature Range.....	-65°C to +150°C
Lead Temperature (Soldering, 10s).....	+260°C
ESD Susceptibility <sup>(1)(2)</sup>	
HBM.....	±2000V
CDM.....	±1000V

**NOTES:**

1. For human body model (HBM), all pins comply with ANSI/ESDA/JEDEC JS-001 specifications.
2. For charged device model (CDM), all pins comply with ANSI/ESDA/JEDEC JS-002 specifications.

**RECOMMENDED OPERATING CONDITIONS**

Common Mode Input Voltage, V <sub>CM</sub> .....	0V to 120V
Operating Supply Voltage, V <sub>S</sub> .....	2.7V to 5.5V
Operating Ambient Temperature Range.....	-40°C to +125°C

**OVERSTRESS CAUTION**

Stresses beyond those listed in Absolute Maximum Ratings may cause permanent damage to the device. Exposure to absolute maximum rating conditions for extended periods may affect reliability. Functional operation of the device at any conditions beyond those indicated in the Recommended Operating Conditions section is not implied.

**ESD SENSITIVITY CAUTION**

This integrated circuit can be damaged if ESD protections are not considered carefully. SGMICRO recommends that all integrated circuits be handled with appropriate precautions. Failure to observe proper handling and installation procedures can cause damage. ESD damage can range from subtle performance degradation to complete device failure. Precision integrated circuits may be more susceptible to damage because even small parametric changes could cause the device not to meet the published specifications.

**DISCLAIMER**

SG Micro Corp reserves the right to make any change in circuit design, or specifications without prior notice.

**PIN CONFIGURATION**

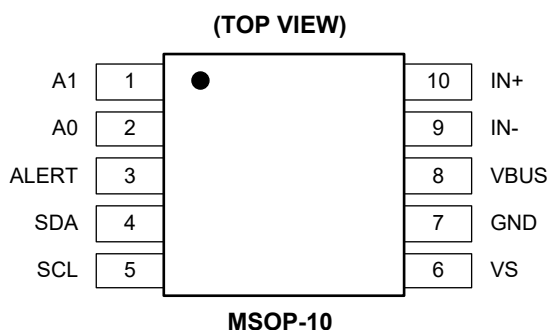

**PIN DESCRIPTION**

PIN	NAME	I/O	FUNCTION
1	A1	DI	I <sup>2</sup> C Address Pin. Connect it to SCL, SDA, GND or VS pin.
2	A0	DI	I <sup>2</sup> C Address Pin. Connect it to SCL, SDA, GND or VS pin.
3	ALERT	DO	Open-Drain Alert Output. Default state is active low.
4	SDA	DI/DO	Serial Bus Data Line, Open-Drain Input/Output.
5	SCL	DI	Serial Bus Clock Line, Open-Drain Input.
6	VS	P	2.7V to 5.5V Power Supply.
7	GND	G	Ground.
8	VBUS	AI	Bus Voltage Input.
9	IN-	AI	Device Negative Input. For high-side applications, connect it to load side of sense resistor. For low-side applications, connect it to ground side of sense resistor.
10	IN+	AI	Device Positive Input. For high-side applications, connect it to power supply side of sense resistor. For low-side applications, connect it to load side of sense resistor.

NOTE: DI = digital input, AI = analog input, DO = digital output, DI/DO = digital input/output, P = power, G = ground.

FUNCTIONAL BLOCK DIAGRAM

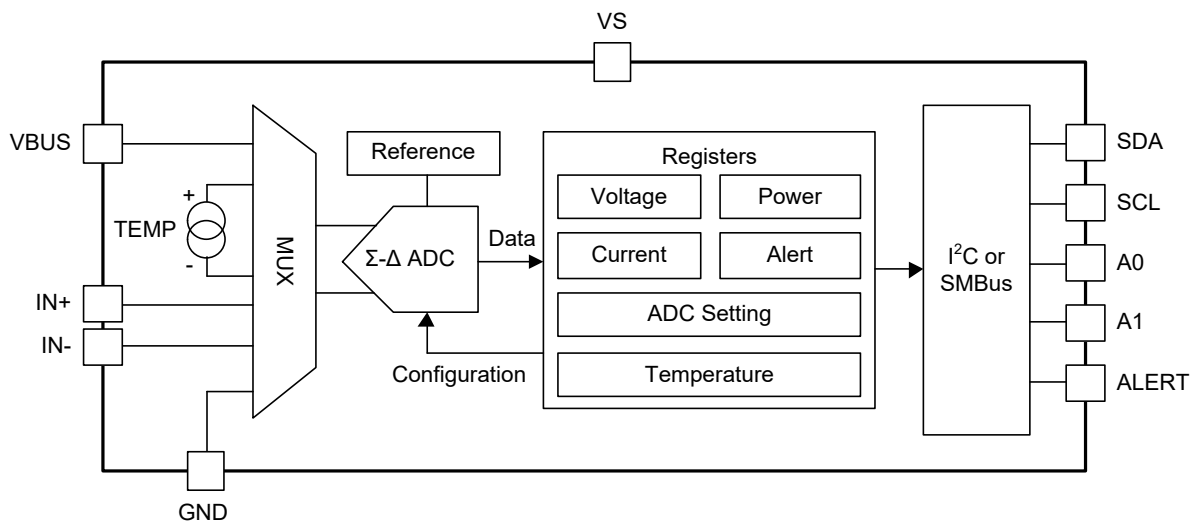
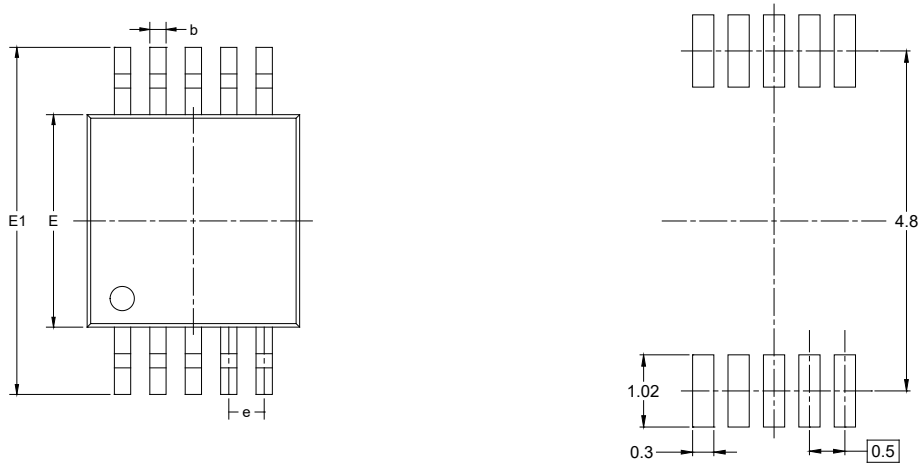

Figure 3. SGM90800A Block Diagram

## PACKAGE OUTLINE DIMENSIONS

### MSOP-10



RECOMMENDED LAND PATTERN (Unit: mm)

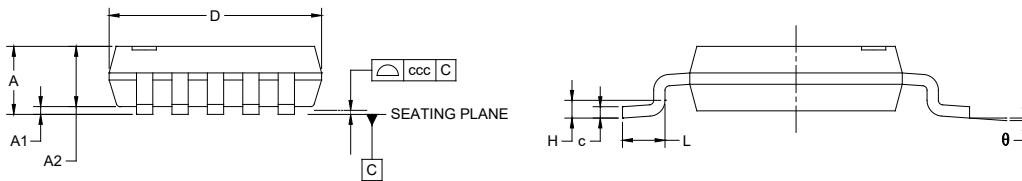

Symbol	Dimensions In Millimeters		
	MIN	NOM	MAX
A	-	-	1.100
A1	0.000	-	0.150
A2	0.750	-	0.950
b	0.170	-	0.330
c	0.080	-	0.230
D	2.900	-	3.100
E	2.900	-	3.100
E1	4.750	-	5.050
e	0.500 BSC		
H	0.250 TYP		
L	0.400	-	0.800
$\theta$	0°	-	8°
ccc	0.100		

**NOTES:**

1. This drawing is subject to change without notice.
2. The dimensions do not include mold flashes, protrusions or gate burrs.
3. Reference JEDEC MO-187.

TAPE AND REEL INFORMATION

REEL DIMENSIONS

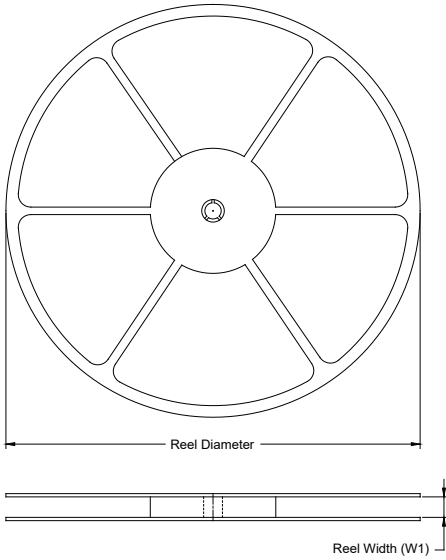

TAPE DIMENSIONS

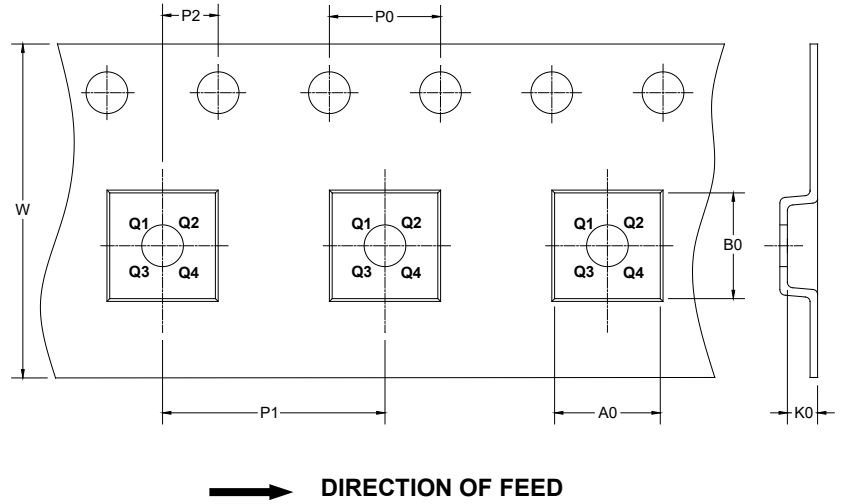

NOTE: The picture is only for reference. Please make the object as the standard.

KEY PARAMETER LIST OF TAPE AND REEL

Package Type	Reel Diameter	Reel Width W1 (mm)	A0 (mm)	B0 (mm)	K0 (mm)	P0 (mm)	P1 (mm)	P2 (mm)	W (mm)	Pin1 Quadrant
MSOP-10	13"	12.4	5.20	3.30	1.50	4.0	8.0	2.0	12.0	Q1

DD0001

# PACKAGE INFORMATION

## CARTON BOX DIMENSIONS

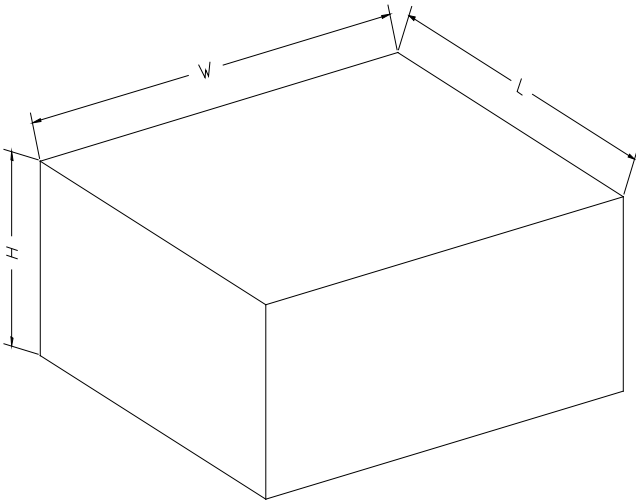

NOTE: The picture is only for reference. Please make the object as the standard.

## KEY PARAMETER LIST OF CARTON BOX

Reel Type	Length (mm)	Width (mm)	Height (mm)	Pizza/Carton
13"	386	280	370	5

DD0002