

GENERAL DESCRIPTION

The SGM42210Q is a high-side driver intended for 12V automotive applications. It is usually used to drive resistive/inductive/capacitive loads with the other terminal connected to ground. If low energy spike occurs on VCC, the internal VCC voltage clamp protects the device.

The device integrates current sense function for sensing load current through the current sense pin current out. If any of following occurs, overload, over-temperature, short-to-VCC, short-to-ground, or open-load during off-state, the sense pin will function to report these faults.

The SGM42210Q SSOP-16 (Exposed Pad) package will be reset by pulling low the nFR_STBY pin. Pulling the IN, nFR_STBY and SEn pins low will disable the device and leave it in standby mode.

The device is AEC-Q100 qualified (Automotive Electronics Council (AEC) standard Q100 Grade 1) and it is suitable for automotive applications.

The SGM42210Q is available in Green SSOP-16 (Exposed Pad) and SSOP-14 (Exposed Pad) packages.

FEATURES

- **AEC-Q100 Qualified for Automotive Applications**
Device Temperature Grade 1
 $T_A = -40^{\circ}\text{C}$ to $+125^{\circ}\text{C}$
- **Max Transient Supply Voltage: 40V**
- **Operating Voltage Range: 5V to 28V**
- **On-Resistance: 6mΩ (TYP)**
- **Nominal Load Current ($T_A = +25^{\circ}\text{C}$): 15A**
- **Adjustable External Current Limit: 66A, 78A, 88A**
- **High-side Switch with Diagnosis and Embedded Protection**
- **Low Off-State Supply Current**
- **3V and 5V Compatible Logic Inputs**
- **Full Set of Protections:**
 - ◆ Thermal Shutdown with Latch or Restart Option
 - ◆ Loss-of-GND and Loss-of-Battery Protection
 - ◆ Open-Load Detection in Off-State
 - ◆ Short-to-GND Protection by Current Limit
 - ◆ Inductive Load Negative Voltage Clamp
 - ◆ Under-Voltage Protection
 - ◆ Over-Voltage Clamp
 - ◆ Reverse Battery Protection with External Ground Network
 - ◆ Electrostatic Discharge Protection

TYPICAL APPLICATION

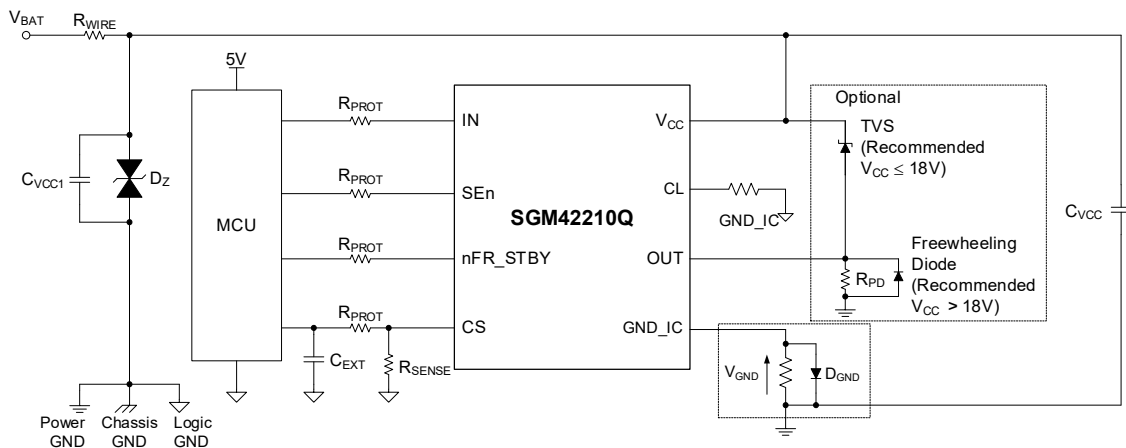

Figure 1. Typical Application Circuit of SSOP-16 (Exposed Pad) Package

PACKAGE/ORDERING INFORMATION

| MODEL | PACKAGE DESCRIPTION | SPECIFIED TEMPERATURE RANGE | ORDERING NUMBER | PACKAGE MARKING | PACKING OPTION |
|-----------|-----------------------|-----------------------------|--------------------|-------------------------|---------------------|
| SGM42210Q | SSOP-16 (Exposed Pad) | -40°C to +125°C | SGM42210QPQS16G/TR | XX#XXXXXXX YY 16K | Tape and Reel, 3000 |
| | SSOP-14 (Exposed Pad) | -40°C to +125°C | SGM42210QPSS14G/TR | XX#XXXXXXX YY 10D | Tape and Reel, 3000 |

MARKING INFORMATION

NOTE: XX#XXXXXXX = Coordinate Information and Wafer ID Number, Date Code, Trace Code and Vendor Code. YY = Lot Number.

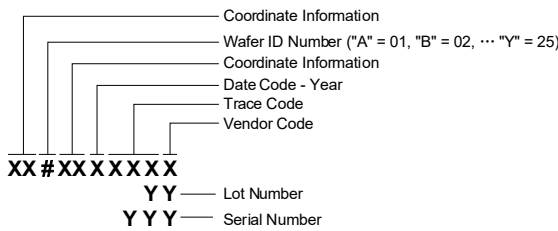

Green (RoHS & HSF): SG Micro Corp defines "Green" to mean Pb-Free (RoHS compatible) and free of halogen substances. If you have additional comments or questions, please contact your SGMICRO representative directly.

ABSOLUTE MAXIMUM RATINGS

| | |
|--|------------------------------|
| DC Supply Voltage, V_{CC} | 38V |
| Reverse DC Supply Voltage, $-V_{CC}$ | 0.3V |
| Load Dump Voltage (ISO 16750-2:2010 Test B Clamped to 40V, $R_L = 4\Omega$, V_{CCPK}) | 40V |
| DC Reverse Ground Pin Current, $-I_{GND}$ | 200mA ⁽¹⁾ |
| DC Output Current, I_{OUT} | Internally Limited |
| DC Input Current | |
| I_{IN} | -1mA to 10mA ⁽¹⁾ |
| I_{SEn} | -1mA to 10mA ⁽¹⁾ |
| nFR_STBY DC Input Current, I_{nFR_STBY} | -1mA to 1.5mA ⁽¹⁾ |
| CS Pin DC Output Current ($V_{GND} = V_{CC}$ and $V_{SENSE} < 0V$), I_{SENSE} | 10mA ⁽¹⁾ |
| CS Pin DC Output Current in Reverse ($V_{CC} < 0V$), I_{SENSE} | -20mA ⁽¹⁾ |
| Maximum Switching Energy (Single Pulse) ($t_{DEMAG} = 0.4ms$, $T_{ASTART} = +125^\circ C$), E_{MAX} | 118mJ |
| Junction Temperature | Internally Limited |
| Package Thermal Resistance | |
| SSOP-16 (Exposed Pad), θ_{JA} | 38.1°C/W |
| SSOP-16 (Exposed Pad), θ_{JB} | 16.3°C/W |
| SSOP-16 (Exposed Pad), $\theta_{JC(TOP)}$ | 41.9°C/W |
| SSOP-16 (Exposed Pad), $\theta_{JC(BOT)}$ | 8.7°C/W |
| SSOP-14 (Exposed Pad), θ_{JA} | 36.5°C/W |
| SSOP-14 (Exposed Pad), θ_{JB} | 15.1°C/W |
| SSOP-14 (Exposed Pad), $\theta_{JC(TOP)}$ | 41.4°C/W |
| SSOP-14 (Exposed Pad), $\theta_{JC(BOT)}$ | 8.7°C/W |
| Storage Temperature Range | -65°C to +150°C |
| Lead Temperature (Soldering, 10s) | +260°C |
| ESD Susceptibility ⁽²⁾⁽³⁾ | |
| HBM (VCC, OUT) | ±6000V |
| HBM (IN, SEn, CS, CL, nFR_STBY) | ±4000V |
| CDM | ±1000V |

NOTES:

1. Guaranteed by design, and not included in the production testing.
2. For human body model (HBM), all pins comply with AEC-Q100-002 specification.
3. For charged device model (CDM), all pins comply with AEC-Q100-011 specification.

RECOMMENDED OPERATING CONDITIONS

Operating Ambient Temperature Range -40°C to +125°C

OVERSTRESS CAUTION

Stresses beyond those listed in Absolute Maximum Ratings may cause permanent damage to the device. Exposure to absolute maximum rating conditions for extended periods may affect reliability. Functional operation of the device at any conditions beyond those indicated in the Recommended Operating Conditions section is not implied.

ESD SENSITIVITY CAUTION

This integrated circuit can be damaged if ESD protections are not considered carefully. SGMICRO recommends that all integrated circuits be handled with appropriate precautions. Failure to observe proper handling and installation procedures can cause damage. ESD damage can range from subtle performance degradation to complete device failure. Precision integrated circuits may be more susceptible to damage because even small parametric changes could cause the device not to meet the published specifications.

DISCLAIMER

SG Micro Corp reserves the right to make any change in circuit design, or specifications without prior notice.

PIN CONFIGURATIONS

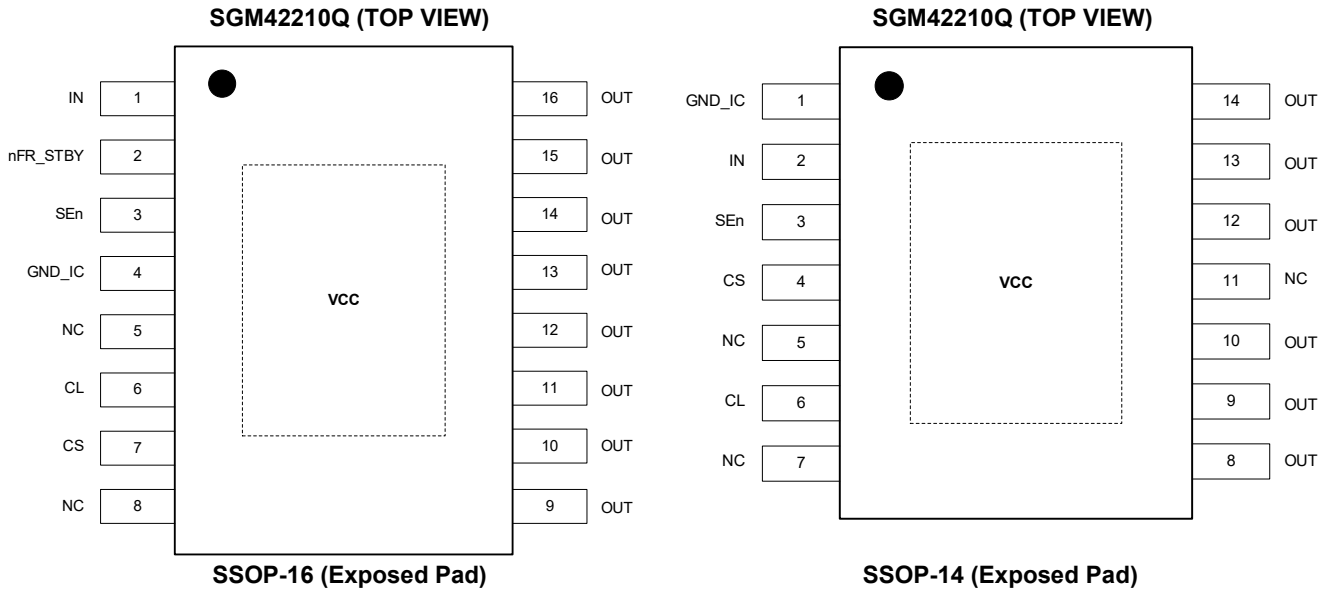

PIN DESCRIPTION

| PIN | | NAME | FUNCTION |
|-------------------------------|-----------------------|----------|---|
| SSOP-16 (Exposed Pad) | SSOP-14 (Exposed Pad) | | |
| 1 | 2 | IN | Control Input, Active-High. |
| 2 | - | nFR_STBY | Active-Low Reset Output/Standby Mode Pin. When over-temperature or over-current occurs and latches, pull nFR_STBY pin down to reset the device. If IN, nFR_STBY and SEn pins are low, the device will enter into standby state. Connect it to the ground through a 15kΩ resistor if not used. |
| 3 | 3 | SEn | Active-High to Enable Device Diagnosis. |
| 4 | 1 | GND_IC | Device Ground. Connect an external diode/resistor network for reverse battery protection. |
| 6 | 6 | CL | Adjustable Current Limit. Connect respective resistor to GND_IC to set the current limit foldback level. If the current limit foldback function is not used, open load this pin. |
| 5, 8 | 5, 7, 11 | NC | No Connection. |
| 7 | 4 | CS | Output Load Current Sense Pin. |
| 9, 10, 11, 12, 13, 14, 15, 16 | 8, 9, 10, 12, 13, 14 | OUT | Power Output. All the output pins should be shorted together. |
| Exposed Pad | | VCC | Battery Connection. |

NOTE: All OUT pins must be shorted together on PCB layout.

Table 1. Recommended Connections

| Connection/Pin | IN | NC | CS | SEn, nFR_STBY | OUT |
|----------------|-----------------------|------------------|----------------------|-----------------------|-------------|
| Floating | X | X ⁽¹⁾ | Not Allowed | X | X |
| To Ground | Through 15kΩ Resistor | X | Through 1kΩ Resistor | Through 15kΩ Resistor | Not Allowed |

NOTE: 1. X = do not care.

ELECTRICAL CHARACTERISTICS

(V_{CC} = 7V to 28V, T_A = -40°C to +125°C. Typical values are measured at V_{CC} = 13V, T_A = +25°C, unless otherwise noted.)

| PARAMETER | SYMBOL | CONDITIONS | MIN | TYP | MAX | UNITS |
|---|--------------------------------------|--|-------------------------|------|-----|-------|
| Power Supplies | | | | | | |
| Operating Supply Voltage | V _{CC} | | 5 | 13 | 28 | V |
| Under-Voltage Shutdown | V _{USD} | | 3.7 | | 4.5 | V |
| Under-Voltage Shutdown Reset | V _{USD_R} | | 4 | | 5 | V |
| Under-Voltage Shutdown Hysteresis | V _{USD_HYS} | | | 0.45 | | V |
| On-Resistance | R _{DSON} | V _{CC} = 7V, I _{OUT} = 5A | | 8.5 | 20 | mΩ |
| | | V _{CC} = 13V, I _{OUT} = 5A | | 6 | 12 | |
| Clamp Voltage | V _{CLAMP} | I _S = 20mA | 41 | 48.5 | 57 | V |
| Supply Current in Standby ⁽¹⁾ | I _{STBY} | V _{CC} = 13V, V _{IN} = V _{SEn} = V _{OUT} = V _{nFR_STBY} = 0V | T _A = +25°C | 0.3 | 0.7 | μA |
| | | | T _A = +125°C | 2 | 5.5 | |
| Standby Mode Blanking Time | t _{D_STBY} | V _{CC} = 13V, V _{IN} = 5V, V _{SEn} = V _{nFR_STBY} = 0V, I _{OUT} = 0A | 30 | 50 | 70 | ms |
| Supply Current | I _{S_ON} | V _{CC} = 13V, V _{SEn} = V _{nFR_STBY} = 0V, V _{IN} = 5V, I _{OUT} = 0A | | 3.5 | 5 | mA |
| Control Stage Current Consumption in On-State | I _{GND_ON} | All channels active, V _{CC} = 13V, V _{SEn} = 5V, V _{nFR_STBY} = 0V, V _{IN} = 5V, I _{OUT} = 5A | | 4.5 | 6 | mA |
| Off-State Output Current ⁽¹⁾ | I _{L_OFF} | V _{IN} = V _{OUT} = 0V, V _{CC} = 13V | T _A = +25°C | 0.1 | 0.3 | μA |
| | | | T _A = +125°C | | 5 | |
| Output - V _{CC} Diode Voltage | V _F | I _{OUT} = -5A, T _A = +125°C | | | 0.7 | V |
| Switching (V_{CC} = 13V) | | | | | | |
| Turn-On Delay Time | t _{D_ON} | R _L = 2.6Ω, T _A = +25°C, see Figure 2 | 7 | 20 | 35 | μs |
| Turn-Off Delay Time | t _{D_OFF} | | 4 | 10 | 16 | |
| Turn-On Voltage Slope | dV _{OUT} /dt _{ON} | R _L = 2.6Ω, T _A = +25°C, see Figure 2 | 0.3 | 0.9 | 1.8 | V/μs |
| Turn-Off Voltage Slope | dV _{OUT} /dt _{OFF} | | 0.3 | 1.1 | 1.8 | |
| Switching Energy Losses at t _{WON} ⁽²⁾ | W _{ON} | R _L = 2.6Ω | | 0.24 | 0.4 | mJ |
| Switching Energy Losses at t _{WOFF} ⁽²⁾ | W _{OFF} | R _L = 2.6Ω | | 0.16 | 0.4 | mJ |
| Differential Pulse Skew | t _{SKREW} | R _L = 2.6Ω, t _{PHL} - t _{PLH} | -40 | 0 | 40 | μs |
| IN | | | | | | |
| Low-Level Input Voltage | V _{IL} | | | | 0.9 | V |
| High-Level Input Voltage | V _{IH} | | 2.1 | | | V |
| Low-Level Input Current | I _{IL} | V _{IN} = 0.9V | 1 | | | μA |
| High-Level Input Current | I _{IH} | V _{IN} = 2.1V | | | 10 | μA |
| Input Hysteresis Voltage | V _{I_HYS} | | | 0.5 | | V |
| Input Clamp Voltage | V _{ICL} | I _{IN} = 1mA | 5.3 | 5.6 | 6.2 | V |
| | | I _{IN} = -1mA | | -0.6 | | |
| nFR_STBY (SSOP-16 (Exposed Pad) Only) | | | | | | |
| Low-Level Input Voltage | V _{nFR_STBY_L} | | | | 0.9 | V |
| High-Level Input Voltage | V _{nFR_STBY_H} | | 1.2 | | | V |
| Low-Level Input Current | I _{nFR_STBY_L} | V _{IN} = 0.9V | 1 | | | μA |
| High-Level Input Current | I _{nFR_STBY_H} | V _{IN} = 2.1V | | | 10 | μA |
| Input Hysteresis Voltage | V _{nFR_STBY_HYS} | | | 0.5 | | V |
| Input Clamp Voltage | V _{nFR_STBY_CL} | I _{IN} = 1mA | 5.3 | 5.6 | 6.2 | V |
| | | I _{IN} = -1mA | | -0.6 | | |

NOTES:

- MOS leakage included.
- Guaranteed by design.

ELECTRICAL CHARACTERISTICS (continued)(V_{CC} = 7V to 28V, T_A = -40°C to +125°C. Typical values are measured at V_{CC} = 13V, T_A = +25°C, unless otherwise noted.)

| PARAMETER | SYMBOL | CONDITIONS | MIN | TYP | MAX | UNITS |
|---|------------------------|--|------------------------------|------|-----|-------|
| SEn | | | | | | |
| Low-Level Input Voltage | V _{SEn_L} | | | | 0.9 | V |
| High-Level Input Voltage | V _{SEn_H} | | 2.1 | | | V |
| Low-Level Input Current | I _{SEn_L} | V _{IN} = 0.9V | 1 | | | μA |
| High-Level Input Current | I _{SEn_H} | V _{IN} = 2.1V | | | 10 | μA |
| Input Hysteresis Voltage | V _{SEn_HYS} | | | 0.5 | | V |
| Input Clamp Voltage | V _{SEn_CL} | I _{IN} = 1mA | 5.3 | 5.6 | 6.2 | V |
| | | I _{IN} = -1mA | | -0.6 | | |
| Protections | | | | | | |
| CL Pin Current | I _{CL} | CL = 0V | V _{CC} = 7V to 18V | | 10 | μA |
| | | | V _{CC} = 21V to 28V | | 20 | |
| DC Short-Circuit Current ⁽¹⁾ | I _{LIMH_13V} | CL = open, V _{CC} = 7V to 18V | 50 | 66 | 82 | A |
| | | CL = 39kΩ to 56kΩ to GND_IC, V _{CC} = 7V to 18V | 58 | 78 | 97 | |
| | | CL short to GND_IC, V _{CC} = 7V to 18V | 70 | 88 | 106 | |
| | I _{LIMH_28V} | V _{CC} = 21V to 28V | 15 | 32 | 42 | |
| Short-Circuit Current during Thermal Cycling ⁽¹⁾ | I _{LIML_13V} | V _{CC} = 7V to 18V | 13 | 26 | 48 | A |
| | | V _{CC} = 21V to 28V | 6 | 13 | 26 | |
| Shutdown Temperature ⁽¹⁾ | T _{SD} | | | 155 | | °C |
| Thermal Hysteresis (T _{SD} - T _R) ⁽¹⁾ | T _{HYS} | | | 10 | | °C |
| Reset Temperature ⁽¹⁾ | T _R | | | 145 | | °C |
| Thermal Reset of Fault Diagnostic Indication ⁽¹⁾ | T _{TRS} | | | 125 | | °C |
| Fault Reset Time for Output Unlatch ⁽¹⁾ | t _{LATCH_RST} | V _{nFR_STBY} = 5V to 0V, V _{SEn} = 5V, V _{IN} = 5V | | 25 | | μs |
| Turn-Off Output Voltage Clamp | V _{DEMAG} | I _{OUT} = 20mA | 39 | 44 | 48 | V |
| Off-State Diagnostic | | | | | | |
| Open-Load Voltage Detection Threshold | V _{OL} | V _{IN} = 0V, V _{SEn} = 5V | 2 | 3 | 4 | V |
| Output Sink Current | I _{L_OFF2} | V _{IN} = 0V, V _{OUT} = 4V | -80 | -32 | -10 | μA |
| Diagnostic Delay Time from Falling Edge of Input | t _{DSTKON} | V _{IN} = 5V to 0V, V _{SEn} = 5V, I _{OUT} = 0A, V _{OUT} = 4V, see Figure 3 | 200 | 350 | 500 | μs |
| Settling Time for Valid Off-State Open-Load Diagnostic Indication from Rising Edge of SEn | t _{D_OL_V} | V _{IN} = 0V, V _{nFR_STBY} = 0V, V _{OUT} = 4V, V _{SEn} = 0V to 5V | | 85 | 150 | μs |
| Delay Time | t _{D_VOL} | V _{IN} = 0V, V _{SEn} = 5V, V _{OUT} = 0V to 4V, from rising edge of V _{OUT} | | 7 | 15 | μs |

NOTE: 1. Parameter guaranteed by design and characterization; not subject to production test.

ELECTRICAL CHARACTERISTICS (continued)(V_{CC} = 7V to 28V, T_A = -40°C to +125°C. Typical values are measured at V_{CC} = 13V, T_A = +25°C, unless otherwise noted.)

| PARAMETER | SYMBOL | CONDITIONS | MIN | TYP | MAX | UNITS | |
|--|---------------------------------|---|--|-------|------|-------|----|
| Current Sense Characteristics (7V < V_{CC} < 18V) | | | | | | | |
| Current Sense Clamp Voltage | V _{SENSE_CL} | V _{SEN} = 0V, I _{SENSE} = -1mA | -15 | -13.5 | -12 | V | |
| | | V _{SEN} = 0V, I _{SENSE} = 1mA | | 9 | | | |
| I _{OUT} /I _{SENSE} ⁽¹⁾ | K ₀ | V _{CC} = 13V, I _{OUT} = 0.25A, V _{SEN} = 5V | 3050 | 4500 | 5900 | | |
| Current Sense Ratio Drift ⁽²⁾ | dK ₀ /K ₀ | V _{CC} = 13V, T _A = +25°C | -10 | | 10 | % | |
| I _{OUT} /I _{SENSE} ⁽¹⁾ | K ₁ | V _{CC} = 13V, I _{OUT} = 1A, V _{SEN} = 5V | 4100 | 4700 | 5200 | | |
| Current Sense Ratio Drift ⁽²⁾ | dK ₁ /K ₁ | V _{CC} = 13V, T _A = +25°C | -4 | | 4 | % | |
| I _{OUT} /I _{SENSE} ⁽¹⁾ | K ₂ | V _{CC} = 13V, I _{OUT} = 6A, V _{SEN} = 5V | 4500 | 4900 | 5200 | | |
| Current Sense Ratio Drift ⁽²⁾ | dK ₂ /K ₂ | V _{CC} = 13V, T _A = +25°C | -4 | | 4 | % | |
| I _{OUT} /I _{SENSE} ⁽¹⁾ | K ₃ | V _{CC} = 13V, I _{OUT} = 18A, V _{SEN} = 5V | 4500 | 4900 | 5200 | | |
| Current Sense Ratio Drift ⁽²⁾ | dK ₃ /K ₃ | V _{CC} = 13V, T _A = +25°C | -4 | | 4 | % | |
| CS Current for OL Detection | I _{SENSE_OL} | I _{OUT} = 0.01A, V _{SENSE} = 0.5V, V _{SEN} = 5V | | | 28 | μA | |
| Current Sense Leakage Current | I _{SENSE0} | CS disabled | V _{SEN} = 0V, V _{SENSE} = -1V to 0V | | | 0.5 | μA |
| | | | V _{SEN} = 0V, V _{SENSE} = 3V | | 0.3 | | |
| | | CS enabled | V _{SEN} = 5V, channel on, I _{OUT} = 0A, diagnostic selected, V _{IN} = 5V, I _{OUT} = 0A | | | 25 | |
| | | | V _{SEN} = 5V, channel off, diagnostic selected, V _{IN} = 0V | | | 0.5 | |
| CS Saturation Voltage | V _{SENSE_SAT} | V _{CC} = 7V, R _{SENSE} = 2.7kΩ, V _{SEN} = 5V, V _{IN} = 5V, I _{OUT} = 18A | 5 | 6.5 | | V | |
| CS Saturation Current ⁽³⁾ | I _{SENSE_SAT} | V _{CC} = 7V, V _{SENSE} = 4V, V _{IN} = 5V, V _{SEN} = 5V | 4 | | | mA | |
| Output Saturation Current ⁽³⁾ | I _{OUT_SAT} | V _{CC} = 7V, V _{SENSE} = 4V, V _{IN} = 5V, V _{SEN} = 5V | 22 | | | A | |
| Fault Diagnostic Feedback (See Truth Table) | | | | | | | |
| Current Sense Output Voltage in Fault Condition | V _{SENSEH} | V _{CC} = 13V, V _{IN} = 0V, V _{SEN} = 5V, I _{OUT} = 0A, V _{OUT} = 4V, R _{SENSE} = 1kΩ | 5 | | 6 | V | |
| Current Sense Output Current in Fault Condition | I _{SENSEH} | V _{CC} = 13V, V _{SENSE} = 5V | 8 | 15 | 22 | mA | |
| Current Sense Timings (Current Sense Mode) (V_{CC} = 13V) | | | | | | | |
| Current Sense Settling Time | t _{DSENSE1H} | From rising edge of SEn, V _{IN} = 5V, V _{SEN} = 0V to 5V, R _{SENSE} = 1kΩ, R _L = 2.6Ω, see Figure 4 | | 5 | 30 | μs | |
| | t _{DSENSE2H} | From rising edge of IN, V _{IN} = 0V to 5V, V _{SEN} = 5V, R _{SENSE} = 1kΩ, R _L = 2.6Ω, see Figure 4 | | 100 | 200 | μs | |
| Delay Response Time between Rising Edge of Output Current and Rising Edge of Current Sense | Δt _{DSENSE2H} | V _{IN} = 5V, V _{SEN} = 5V, R _{SENSE} = 1kΩ, R _L = 2.6Ω, I _{SENSE} = 80% of I _{SENSEMAX} , I _{OUT} = 80% of I _{OUTMAX} | | | 150 | μs | |
| Current Sense Disable Delay Time | t _{DSENSE1L} | From falling edge of SEn, V _{IN} = 5V, V _{SEN} = 5V to 0V, R _{SENSE} = 1kΩ, R _L = 2.6Ω, see Figure 4 | | 3 | 20 | μs | |
| Current Sense Turn-Off Delay Time | t _{DSENSE2L} | From falling edge of IN, V _{IN} = 5V to 0V, V _{SEN} = 5V, R _{SENSE} = 1kΩ, R _L = 2.6Ω, see Figure 4 | | 3 | 20 | μs | |

NOTES:

- Not include lifetime drift.
- +25°C lifetime drift.
- Parameter guaranteed by design and characterization; not subject to production test.

TIMING DIAGRAM

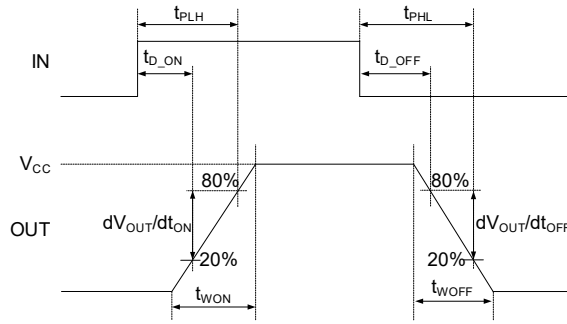

Figure 2. Timing Diagram

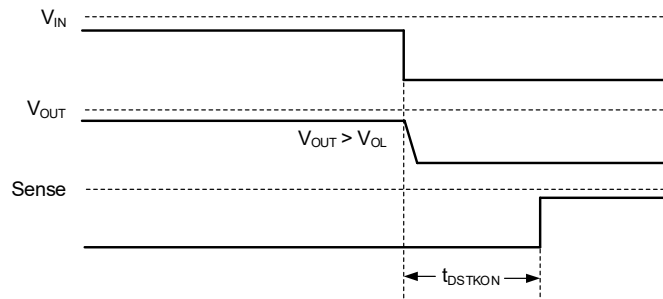

Figure 3. Diagnostic Delay Time from Falling Edge of Input (t_{DSTKON})

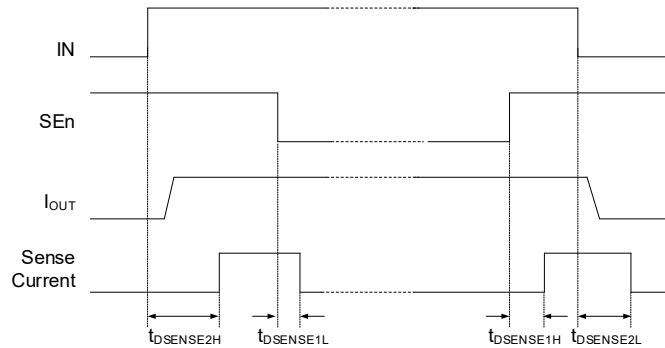
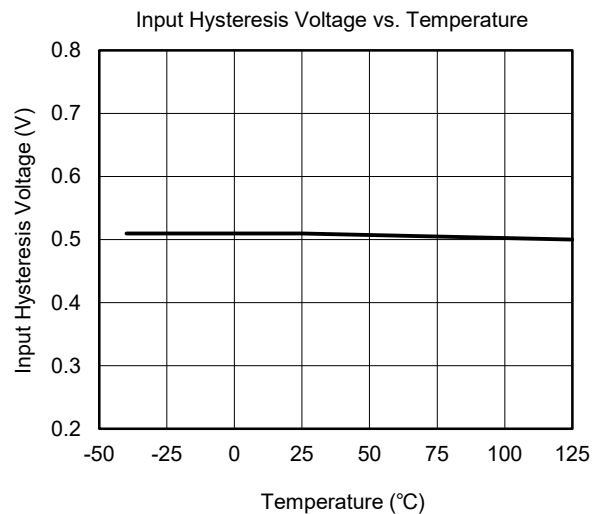
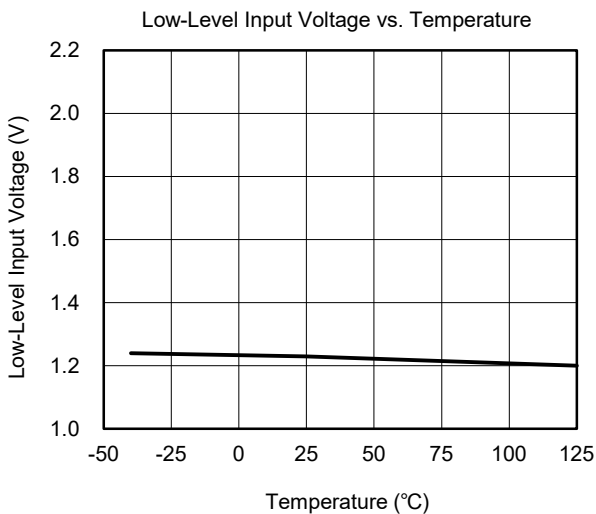
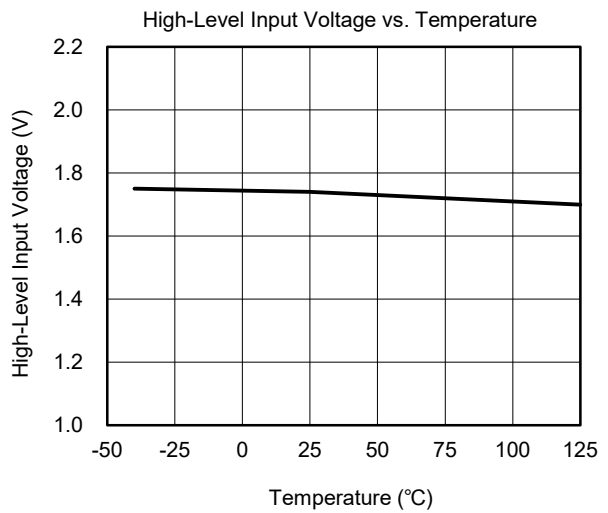
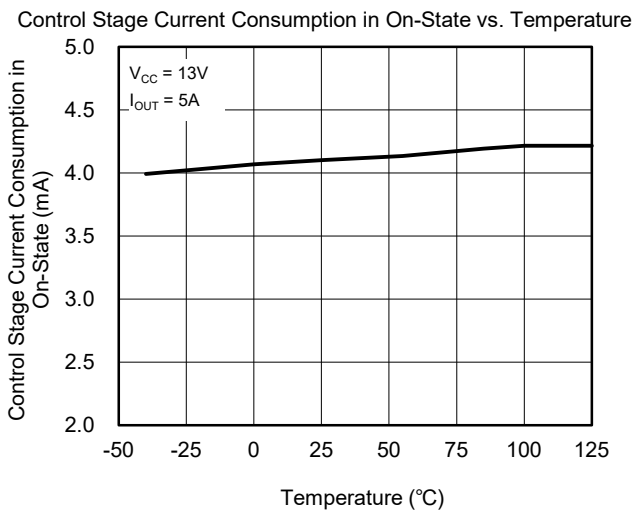
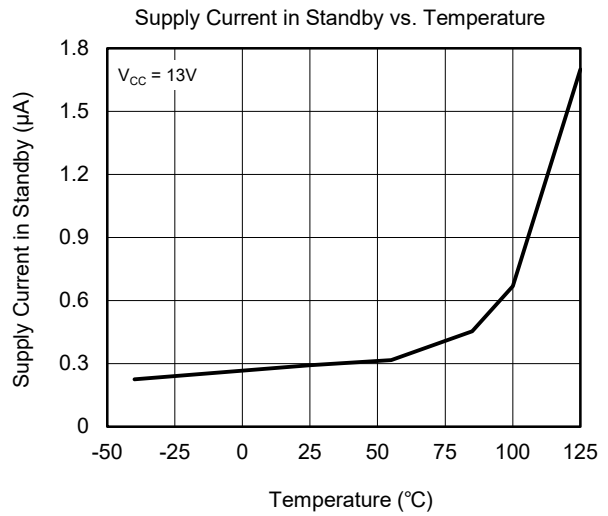
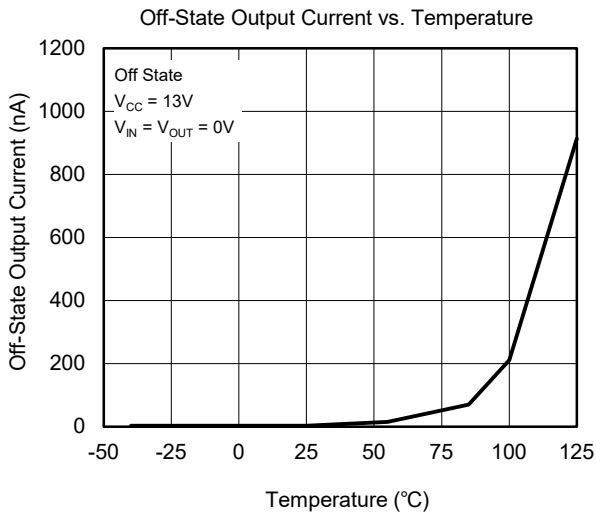

Figure 4. Current Sense Timing (Current Sense Mode)

TYPICAL PERFORMANCE CHARACTERISTICS

T_A = +25°C, unless otherwise noted.



TYPICAL PERFORMANCE CHARACTERISTICS (continued)

T_A = +25°C, unless otherwise noted.

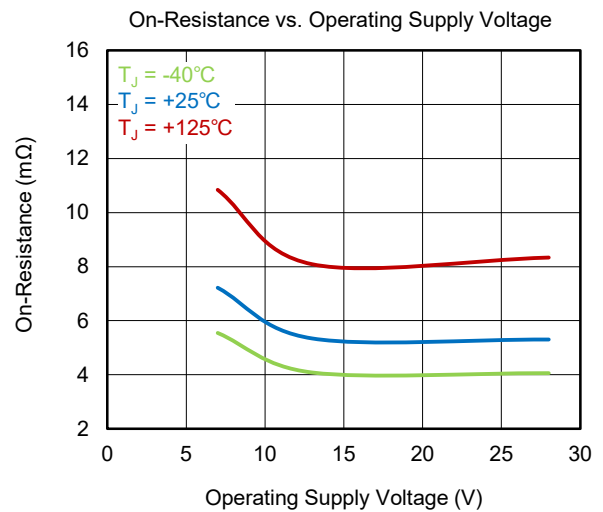
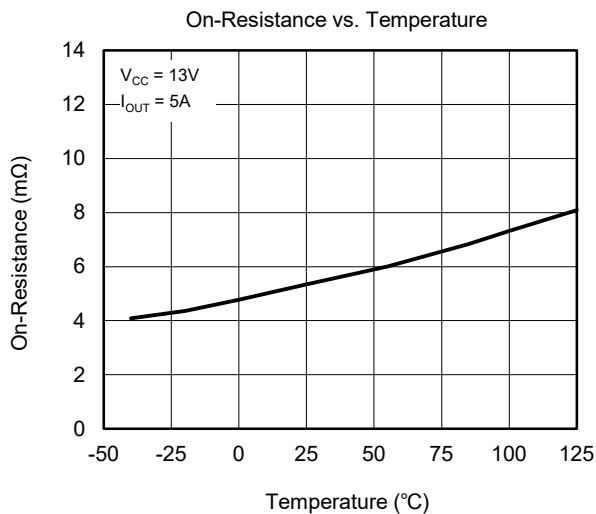
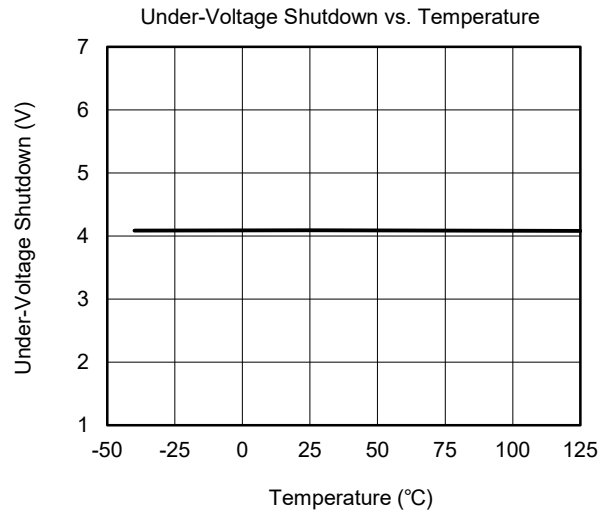
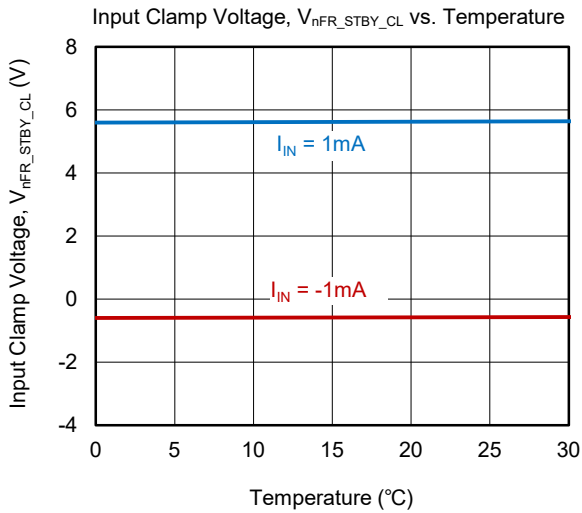
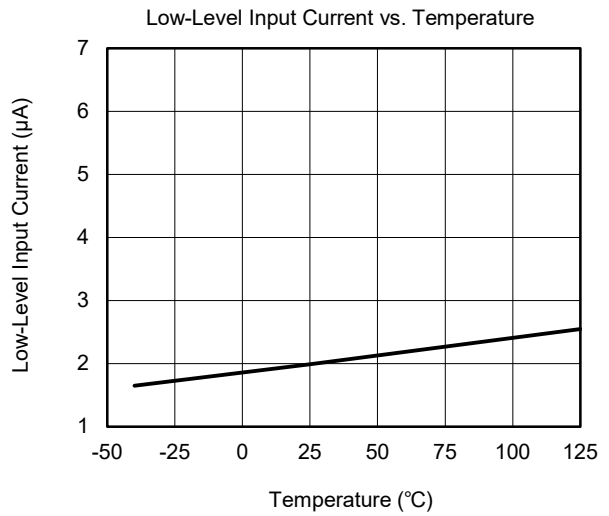
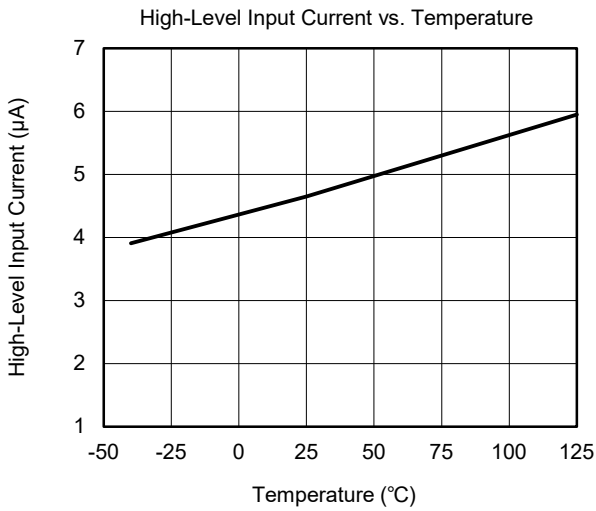

TYPICAL PERFORMANCE CHARACTERISTICS (continued)

T_A = +25°C, unless otherwise noted.

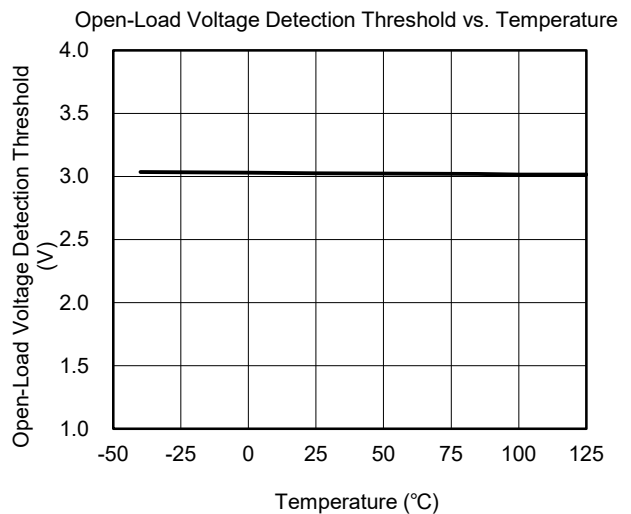
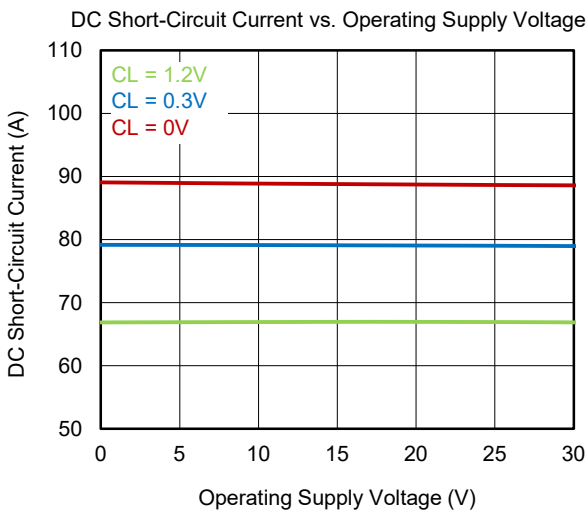
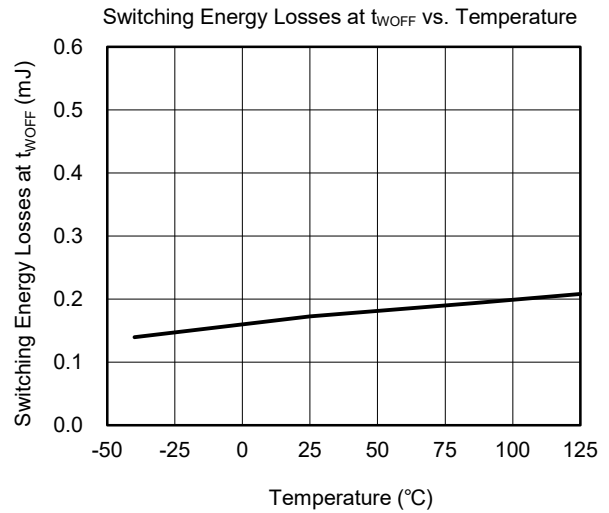
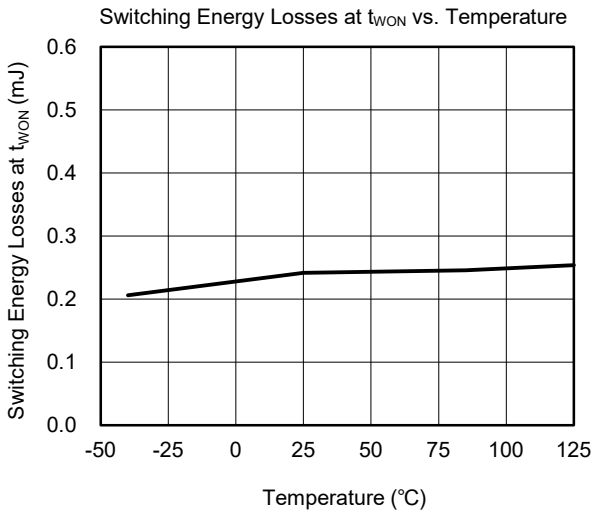
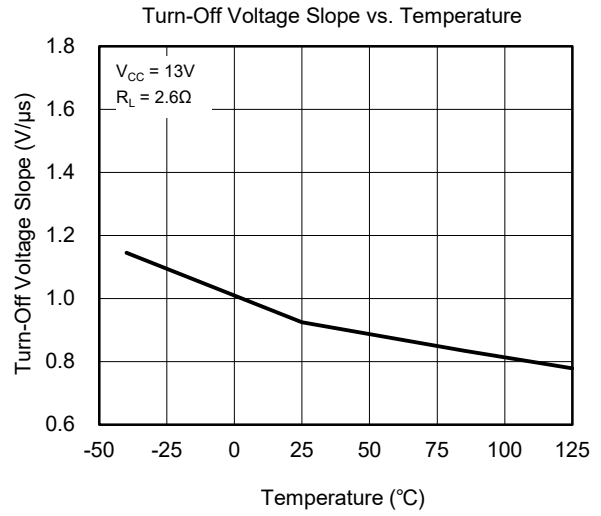
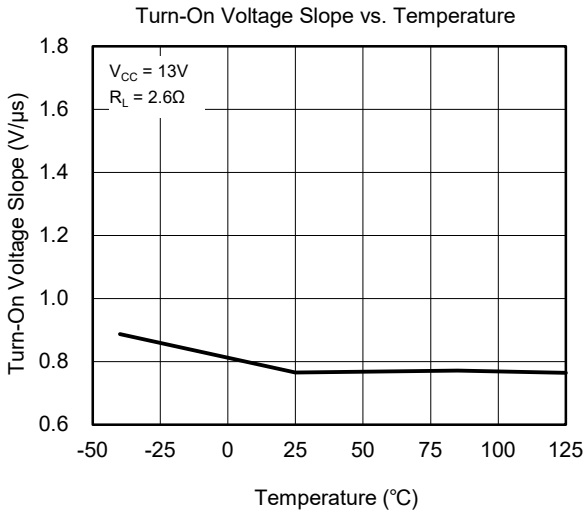

TYPICAL PERFORMANCE CHARACTERISTICS (continued)

T_A = +25°C, unless otherwise noted.

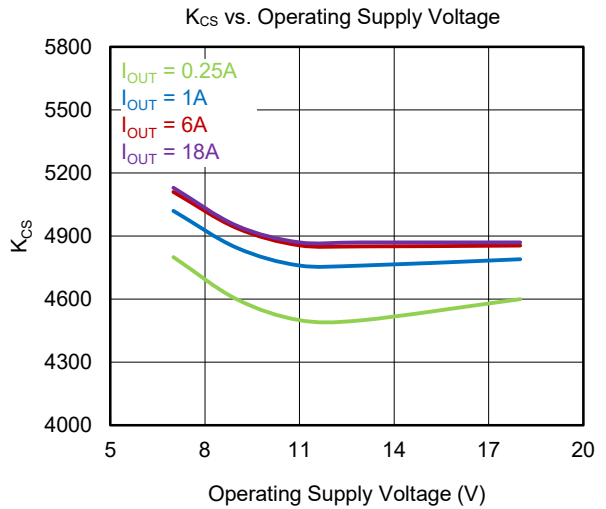
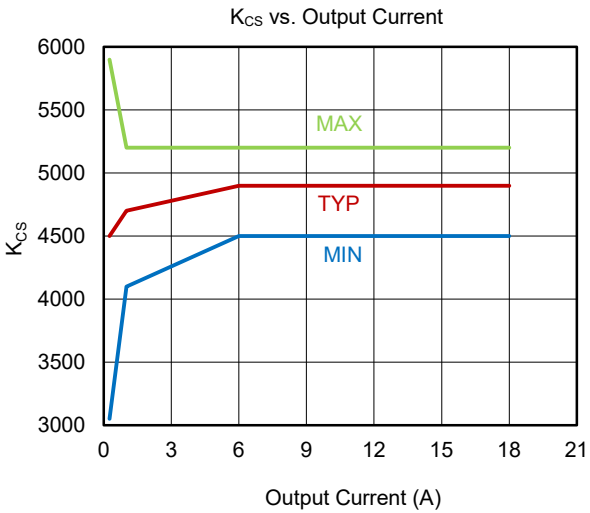
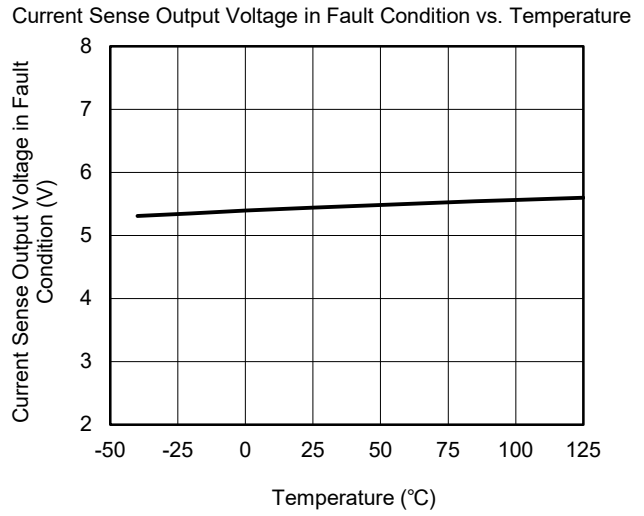
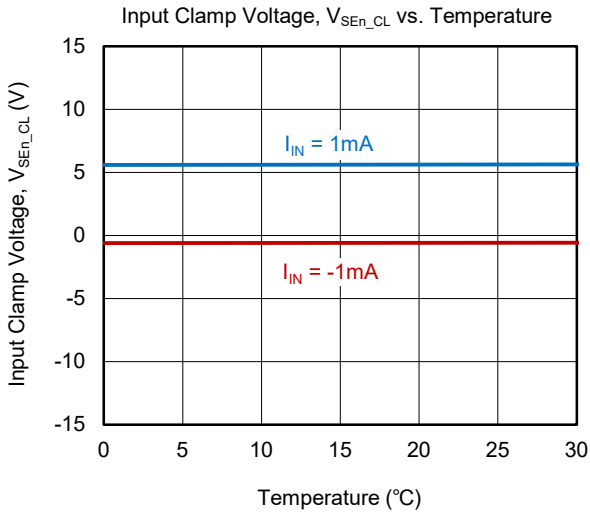

FUNCTIONAL BLOCK DIAGRAMS

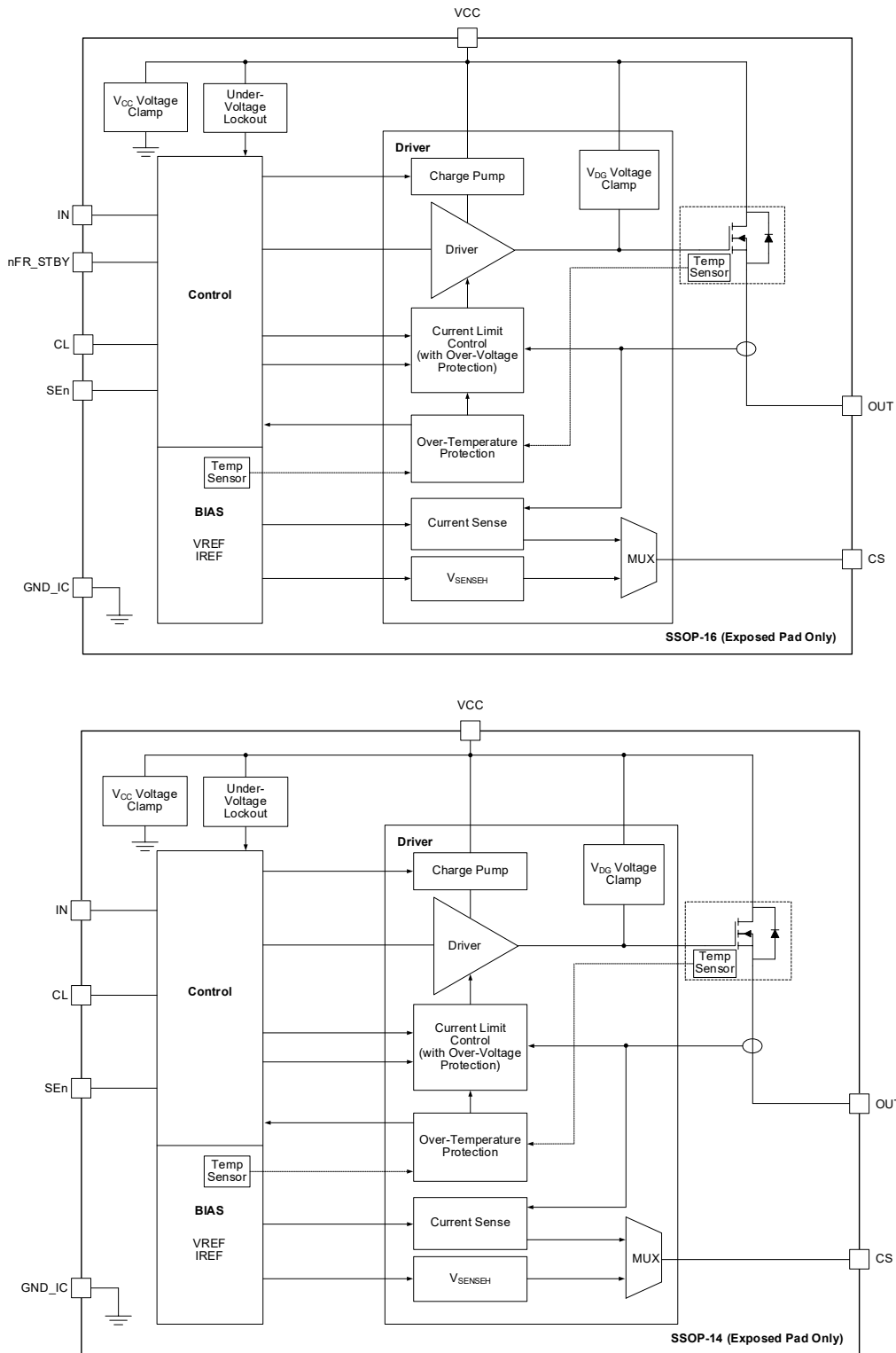

Figure 5. Block Diagrams

DETAILED DESCRIPTION

Latch Functionality:

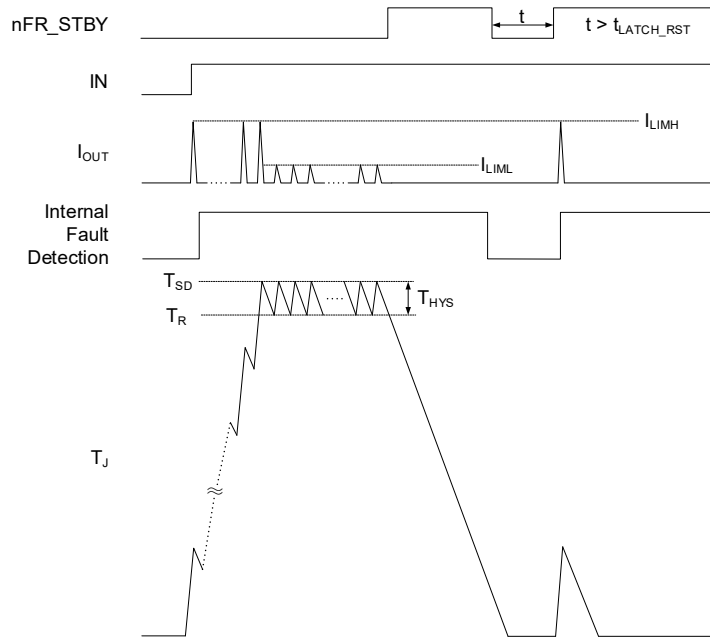

Figure 6. Device Behavior in Hard Short-Circuit Condition

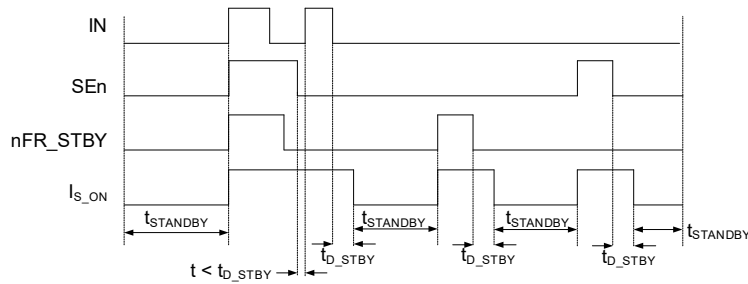

Figure 7. Standby Mode Activation

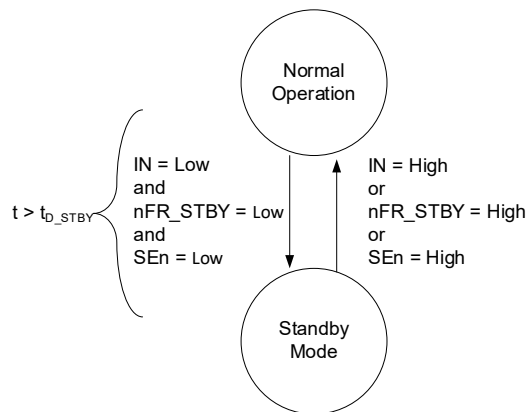

Figure 8. Standby State Diagram

DETAILED DESCRIPTION (continued)

Table 2. Truth Table of SSOP-16 (Exposed Pad) Package

| Mode | Conditions | IN | nFR_STBY | SEn | OUT | Current Sense | Comments |
|----------------------------|--|----|----------|---------------------|------|---------------------|--|
| Standby | All logic inputs low | L | L | L | L | Hi-Z | Low quiescent current consumption |
| Normal | Nominal load connected, $T_A \leq +125^\circ\text{C}$ | L | X | Refer to Table 5 | L | Refer to Table 5 | |
| | | H | L | | H | | Outputs configured for auto-restart |
| | | H | H | | H | | Outputs configured for latch-off |
| Overload | Overload or short-to-GND causing: $T_{FET} > T_{SD}$ or $T_{CTR} > T_{SD}$ | L | X | Refer to Table 5 | L | Refer to Table 5 | |
| | | H | L | | H | | Output cycles with temperature hysteresis |
| | | H | H | | L | | Output latches-off |
| Under-Voltage | $V_{CC} < V_{USD}$ (falling) | X | X | X | L | Hi-Z | Restart when $V_{CC} > V_{USD} + V_{USD_HYS}$ (rising) |
| Off-State Diagnostics | Short-to- V_{CC} | L | X | Refer to Table 5 | H | Refer to Table 5 | |
| | Open-load | L | X | | H | | External pull-up |
| Negative Output Voltage | Inductive loads turn-off | L | X | Refer to Table 5 | < 0V | Refer to Table 5 | |

Table 3. Truth Table of SSOP-14 (Exposed Pad) Package

| Mode | Conditions | IN | SEn | OUT | Current Sense | Comments |
|----------------------------|---|----|---------------------|------|---------------------|--|
| Standby | All logic inputs low | L | L | L | Hi-Z | Low quiescent current consumption |
| Normal | Nominal load connected, $T_A \leq +125^\circ\text{C}$ | L | Refer to Table 5 | L | Refer to Table 5 | |
| | | H | | H | | Outputs configured for auto-restart |
| Overload | Overload or short-to-GND causing: $T_{FET} > T_{SD}$ or $T_{CTR} > T_{SD}$ | L | Refer to Table 5 | L | Refer to Table 5 | |
| | | H | | H | | Output cycles with temperature hysteresis |
| Under-Voltage | $V_{CC} < V_{USD}$ (falling) | X | X | L | Hi-Z | Restart when $V_{CC} > V_{USD} + V_{USD_HYS}$ (rising) |
| Off-State Diagnostics | Short-to- V_{CC} | L | Refer to Table 5 | H | Refer to Table 5 | |
| | Open-load | L | | H | | External pull-up |
| Negative Output Voltage | Inductive loads turn-off | L | Refer to Table 5 | < 0V | Refer to Table 5 | |

DETAILED DESCRIPTION (continued)

Table 4. Local Thermal Sense Based T_{SD} and T_{TRS} Truth Table

| Power FET | Controller | Driver Behavior | |
|---|---|-------------------|--|
| | | Current Limit | State |
| T _{FET} < T _{TRS_FET} | T _{CTR} < T _{TRS_CTR} | I _{LIMH} | On |
| T _{TRS_FET} < T _{FET} < T _{SD_FET} | | I _{LIML} | On |
| T _{SD_FET} < T _{FET} | | | Off |
| T _{FET} < T _{SD_FET} | T _{TRS_CTR} < T _{CTR} < T _{SD_CTR} | I _{LIML} | On |
| T _{SD_FET} < T _{FET} | | | Off |
| Don't Care | | | T _{SD_CTR} < T _{CTR} |

SGM42210Q implemented local thermal sense function in power FET and controller. The behavior of power FET depends on the external command and the thermal information. Each power FET has independent thermal sense and current limit regulation capability while controller temperature is lower than T_{TRS}. Besides, the controller has higher priority in thermal protection. Once the T_{SD} signal of controller thermal sense is triggered, all power FET will be shut down immediately until the controller temperature lower than T_{SD} - T_{HYS}. Then in thermal cycling period, current limit will be reduced to I_{LIML} until controller temperature lower than T_{TRS}.

Table 5. Current Sense

| SEn | Mode | Current Sense Output | | | |
|-----|-------------------|---|--|--|-----------------|
| | | Normal Mode | Overload | Off-State Diagnostic | Negative Output |
| L | | Hi-Z | | | |
| H | Output Diagnostic | I _{SENSE} = 1/K × I _{OUT} | V _{SENSE} = V _{SENSEH} | V _{SENSE} = V _{SENSEH} | Hi-Z |

NOTE: If the output channel is latched off while the input is low, the CS pin delivers feedback according to off-state diagnostic.

Example 1: nFR_STBY = 1, IN = 0, OUT = L (latched), channel = diagnostic, CS = 0.

Example 2: nFR_STBY = 1, IN = 0, OUT = latched, V_{OUT} > V_{OL}, channel = diagnostic, CS = V_{SENSEH}.

Thermal Shutdown

Thermal shutdown is active when the absolute temperature T_{FET} > T_{SD} or T_{CTR} > T_{SD}. When thermal shutdown occurs, the output turns off. The nFR_STBY pin is used to configure the behavior after the thermal shutdown occurs.

- When the nFR_STBY pin is low, thermal shutdown operates in the auto-restart mode. The output automatically recovers when T_{FET} < T_R or T_{CTR} < T_R, but the current is limited to I_{LIM_L} during thermal cycling. The fault signal is cleared when T_{FET} < T_{TRS} or T_{CTR} < T_{TRS} or after toggling the related IN pin.
- When the nFR_STBY pin is high, thermal shutdown operates in the latch mode. The output latches off when thermal shutdown occurs. When the nFR_STBY pin goes from high to low, thermal shutdown changes to auto-restart mode.

APPLICATION INFORMATION

Reverse Battery Protection with External Ground Network

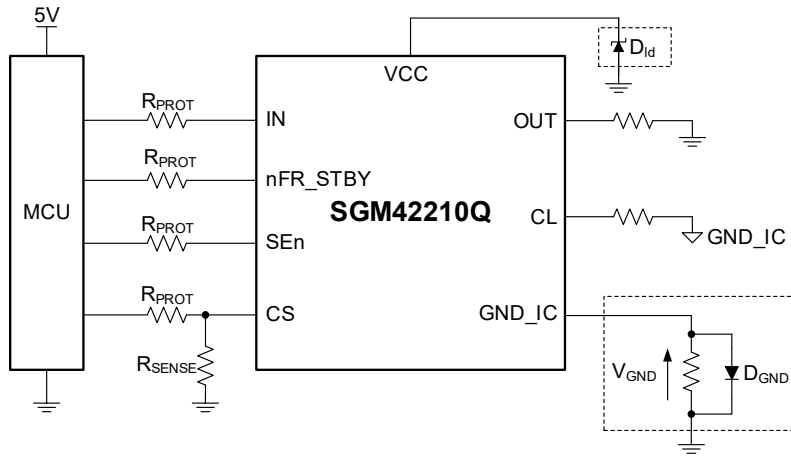

Figure 9. Reverse Battery Protection with External Ground Network of SSOP-16 (Exposed Pad) Package

D_GND in the GND Line

Adding a GND network. The reverse current through the GND_IC is blocked. The reverse current through the FET is limited by the load itself. A resistor in parallel with the diode is recommended as a GND network. The recommended selection is 4.7kΩ resistor in parallel with the diode.

The reverse current protection diode will bring about 0.6V level shift on the input voltage threshold.

Immunity Test According to Automotive Standard

Testing the device for compliance with EMC/EMI standards is important for automotive customers.

ISO 7637 is titled “road vehicles - electrical disturbances from conduction and coupling”, and part 2 is specifically “electrical transient conduction along supply lines only.” As high-side driver is connected directly from automotive battery power supply, this is very relevant. Also load dump test according to ISO 16750-2:2010 is one of the crucial test for automotive customers.

Functional Class B

All functions of the device/system are performed as designed during the test. However, one or more may go beyond the specified tolerance. All functions return automatically to within normal limits after the test.

Table 6. Electrical Transient Requirements

| ISO 7637-2: 2011(E) Test Pulse | Test Pulse Severity Level with Status II Functional Performance Status | | Minimum Number of Pulses or Test Time | Burst Cycle/Pulse Repetition Time | | Pulse Duration and Pulse Generator Internal Impedance |
|---|--|-------------------------------|---------------------------------------|-----------------------------------|-------|---|
| | Level | U _s ⁽¹⁾ | | MIN | MAX | |
| 1 | III | -112V | 500 pulses | 0.5s | | 2ms, 10Ω |
| 2a ⁽³⁾ | III | +55V | 500 pulses | 0.2s | 5s | 50μs, 2Ω |
| 3a | IV | -220V | 1h | 90ms | 100ms | 0.1μs, 50Ω |
| 3b | IV | +150V | 1h | 90ms | 100ms | 0.1μs, 50Ω |
| 4 ⁽²⁾ | IV | -7V | 1 pulse | | | 100ms, 0.01Ω |
| Load dump according to ISO 16750-2:2010 | | | | | | |
| Test B ⁽³⁾ | | 40V | 5 pulse | 1min | | 400ms, 2Ω |

NOTES:

1. U_s is the peak amplitude as defined for each test pulse in ISO 7637-2:2011(E), chapter 5.6.
2. Test pulse from ISO 7637-2:2004(E).
3. With 40V external suppressor referred to ground (-40°C < T_A < +125°C).

APPLICATION INFORMATION (continued)

Current Sense

A current mirror is a circuit that is specially designed to copy the current flowing through an active device. This ratio K is a fixed value and cannot be changed by the user. The CS pin can also report a fault with V_{SENSEH} voltage during fault condition.

Normal Operation

While device is working in normal conditions, output is on, no fault and SEn is active.

One integrated current mirror can source $1/K_{CS}$ of the load current: $I_{SENSE} = I_{OUT} \times 1/K_{CS}$.

$$V_{SENSE} = R_{SENSE} \times I_{SENSE} = R_{SENSE} \times I_{OUT}/K_{CS} \tag{2}$$

where:

V_{SENSE} is the voltage on R_{SENSE} .

I_{SENSE} is the current source out from CS pin.

I_{OUT} is the current flowing through output.

K_{CS} is the current mirror ratio.

Fault Indication

During a fault condition, for example over-temperature/overload/open-load, the CS pin outputs V_{SENSEH} voltage to indicate the fault.

SSOP-16 (Exposed Pad) Package:

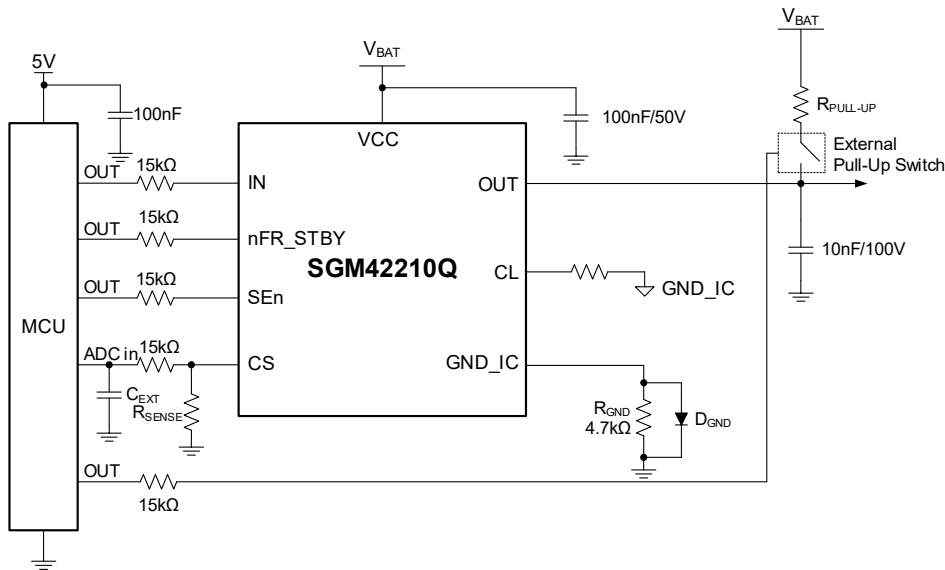

Figure 12. Open-Load Detection in Off-State (Analog HSD)

APPLICATION INFORMATION (continued)

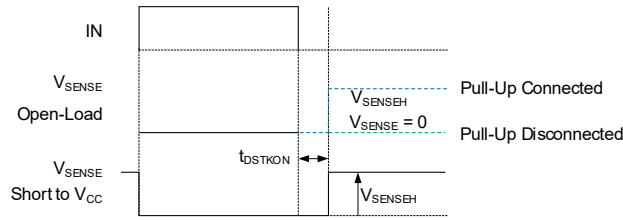

Figure 13. Open-Load/Short-to-VCC

Table 7. Current Sense Pin Levels in Off-State

| Condition | Output | CS | SEn |
|--------------|--------------------|--------------|-----|
| Open-Load | $V_{OUT} > V_{OL}$ | Hi-Z | L |
| | $V_{OUT} < V_{OL}$ | V_{SENSEH} | H |
| Short-to-VCC | $V_{OUT} > V_{OL}$ | Hi-Z | L |
| | $V_{OUT} < V_{OL}$ | 0 | H |
| Nominal | $V_{OUT} > V_{OL}$ | Hi-Z | L |
| | $V_{OUT} < V_{OL}$ | 0 | H |

Short-to-Battery

In off-state, short-to-battery has the same detection mechanism and behavior as open-load detection.

Off-State Open-Load Pull-Up Resistor

There is always a leakage current I_{L_OFF} present on the output due to internal logic control path or external humidity, corrosion, and so forth. In off-state, external pull-up resistor is needed for open-load detection. R_{PU} should be selected to make sure that $V_{OUT} > V_{OL_MAX}$ please refer to the calculation below:

$$R_{PU} < \frac{V_{PU} - 4}{I_{L_OFF2_MIN@4V}}$$

REVISION HISTORY

NOTE: Page numbers for previous revisions may differ from page numbers in the current version.

| Revision | Page |
|---|------|
| FEBRUARY 2026 – REV.A.1 to REV.A.2 | |
| Updated Electrical Characteristics | 6 |
| JANUARY 2026 – REV.A to REV.A.1 | |
| Updated package marking..... | 2 |
| Changes from Original to REV.A (DECEMBER 2025) | |
| Changed from product preview to production data..... | All |

PACKAGE OUTLINE DIMENSIONS

SSOP-14 (Exposed Pad)

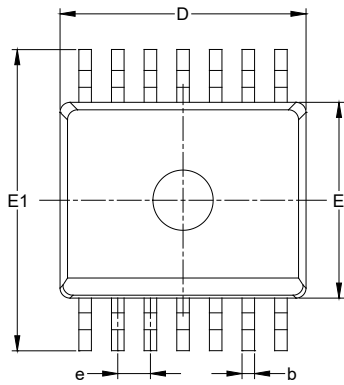

TOP VIEW

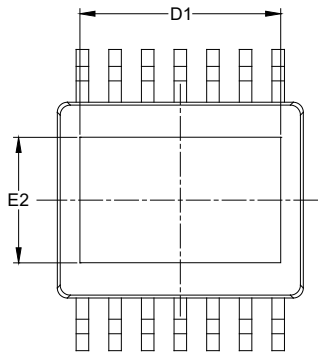

BOTTOM VIEW

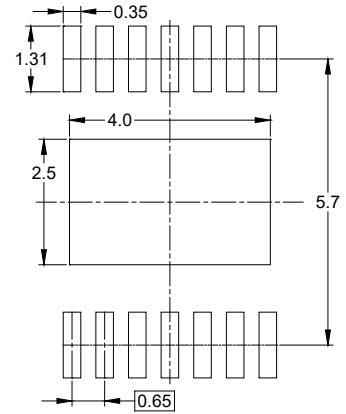

RECOMMENDED LAND PATTERN (Unit: mm)

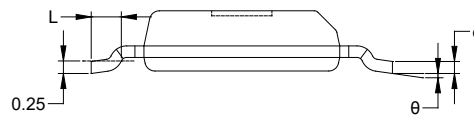
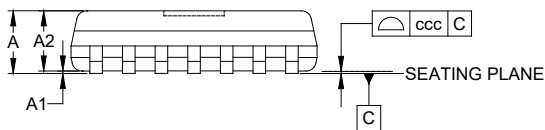

| Symbol | Dimensions in Millimeters | | |
|--------|---------------------------|-----|-------|
| | MIN | NOM | MAX |
| A | - | - | 1.400 |
| A1 | 0.000 | - | 0.100 |
| A2 | 1.200 REF | | |
| b | 0.200 | - | 0.300 |
| c | 0.190 | - | 0.280 |
| D | 4.800 | - | 5.000 |
| D1 | 3.800 | - | 4.200 |
| E | 3.800 | - | 4.000 |
| E1 | 5.800 | - | 6.200 |
| E2 | 2.300 | - | 2.700 |
| e | 0.650 BSC | | |
| L | 0.400 | - | 0.850 |
| θ | 0° | - | 8° |
| ccc | 0.100 | | |

NOTES:

1. This drawing is subject to change without notice.
2. The dimensions do not include mold flashes, protrusions or gate burrs.

PACKAGE OUTLINE DIMENSIONS

SSOP-16 (Exposed Pad)

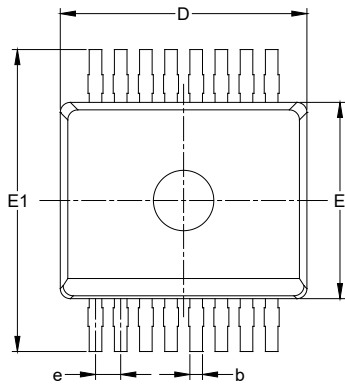

TOP VIEW

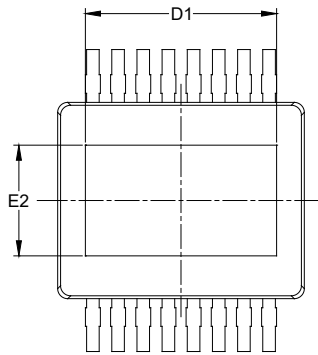

BOTTOM VIEW

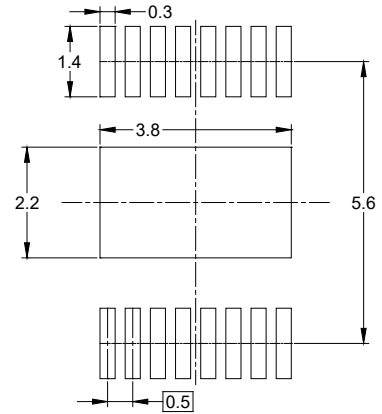

RECOMMENDED LAND PATTERN (Unit: mm)

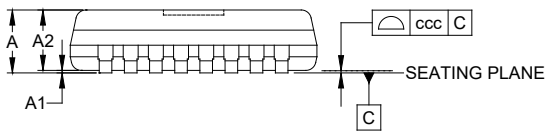

| Symbol | Dimensions in Millimeters | | |
|--------|---------------------------|-----|-------|
| | MIN | NOM | MAX |
| A | - | - | 1.400 |
| A1 | 0.000 | - | 0.100 |
| A2 | 1.200 REF | | |
| b | 0.200 | - | 0.300 |
| c | 0.190 | - | 0.280 |
| D | 4.800 | - | 5.000 |
| D1 | 3.600 | - | 4.200 |
| E | 3.800 | - | 4.000 |
| E1 | 5.800 | - | 6.200 |
| E2 | 1.900 | - | 2.500 |
| e | 0.500 BSC | | |
| L | 0.400 | - | 0.850 |
| θ | 0° | - | 8° |
| ccc | 0.100 | | |

NOTES:

1. This drawing is subject to change without notice.
2. The dimensions do not include mold flashes, protrusions or gate burrs.

PACKAGE INFORMATION

TAPE AND REEL INFORMATION

REEL DIMENSIONS

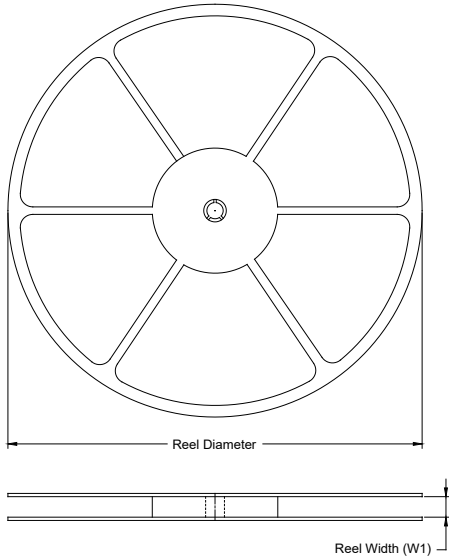

TAPE DIMENSIONS

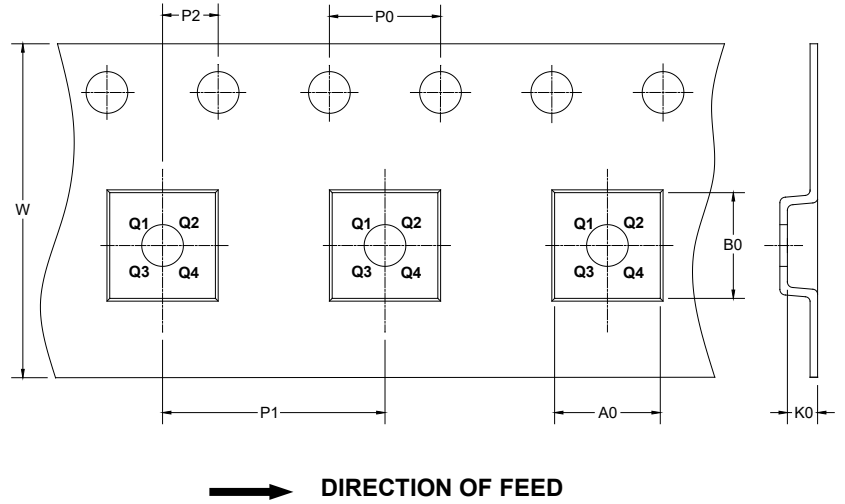

NOTE: The picture is only for reference. Please make the object as the standard.

KEY PARAMETER LIST OF TAPE AND REEL

| Package Type | Reel Diameter | Reel Width W1 (mm) | A0 (mm) | B0 (mm) | K0 (mm) | P0 (mm) | P1 (mm) | P2 (mm) | W (mm) | Pin1 Quadrant |
|--------------------------|---------------|--------------------|---------|---------|---------|---------|---------|---------|--------|---------------|
| SSOP-16 (Exposed Pad) | 13" | 12.4 | 6.50 | 5.25 | 1.70 | 4.0 | 8.0 | 2.0 | 12.0 | Q1 |
| SSOP-14 (Exposed Pad) | 13" | 12.4 | 6.50 | 5.25 | 1.70 | 4.0 | 8.0 | 2.0 | 12.0 | Q1 |

D20001

PACKAGE INFORMATION

CARTON BOX DIMENSIONS

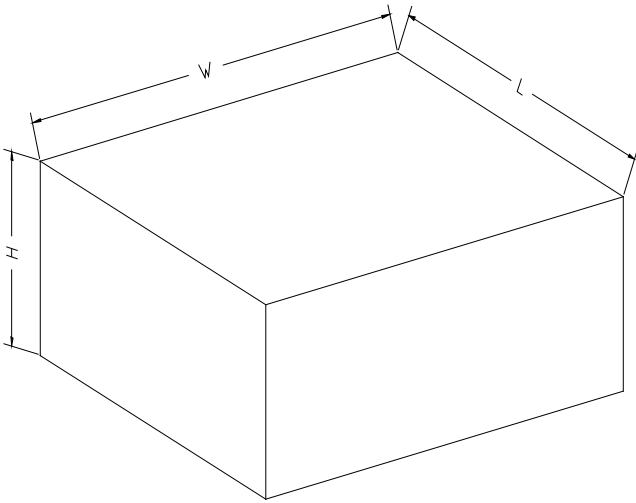

NOTE: The picture is only for reference. Please make the object as the standard.

KEY PARAMETER LIST OF CARTON BOX

| Reel Type | Length (mm) | Width (mm) | Height (mm) | Pizza/Carton |
|-----------|-------------|------------|-------------|--------------|
| 13" | 386 | 280 | 370 | 5 |

DD0002