

### GENERAL DESCRIPTION

The 74HC164 is an 8-bit serial-in and parallel-out shift register which can accept a wide supply voltage range from 2.0V to 6.0V.

This device provides gated serial inputs (DSA and DSB) and parallel data outputs (Q0 to Q7). DSA and DSB support serial data entry, where either input can allow data to enter through another input as an active-high input. CP is a clock input. When the device is on low-to-high clock transition of the CP, data can be shifted.  $\overline{MR}$  is the master reset input that is separated from the other inputs. When  $\overline{MR}$  is held low, it can make the register clear and all outputs must be low level. The clamp diodes of inputs allow the use of current limiting resistors to connect inputs to the voltage exceeding supply voltage.

The 74HC164 is available in Green SOIC-14 and TSSOP-14 packages. It operates over a temperature range of -40°C to +125°C.

### FEATURES

- **Wide Operating Voltage Range: 2.0V to 6.0V**
- **CMOS Low Power Consumption**
- **Gated Serial Data Inputs**
- **Asynchronous Master Reset Input**
- **-40°C to +125°C Operating Temperature Range**
- **Available in Green SOIC-14 and TSSOP-14 Packages**

### APPLICATIONS

Servers and I/O Expanders  
LED Displays

### LOGIC DIAGRAM

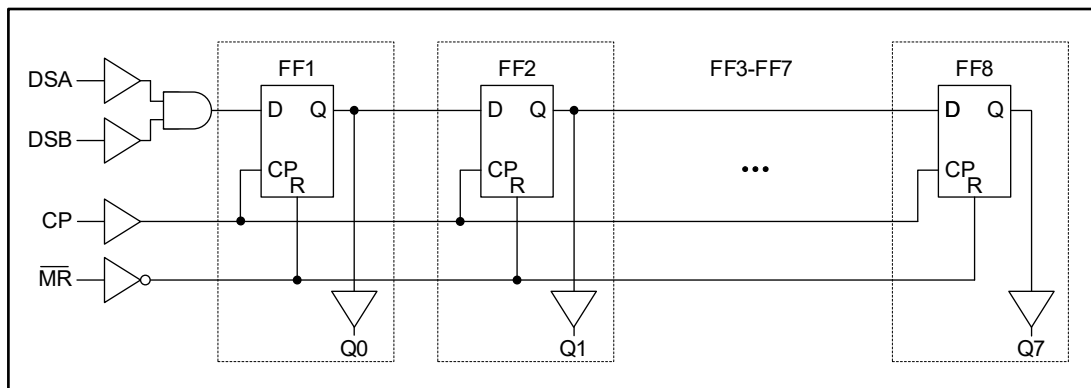

## PACKAGE/ORDERING INFORMATION

MODEL	PACKAGE DESCRIPTION	SPECIFIED TEMPERATURE RANGE	ORDERING NUMBER	PACKAGE MARKING	PACKING OPTION
74HC164	SOIC-14	-40°C to +125°C	74HC164XS14G/TR	74HC164XS14 XXXXX	Tape and Reel, 2500
	TSSOP-14	-40°C to +125°C	74HC164XTS14G/TR	74HC164 XTS14 XXXXX	Tape and Reel, 4000

## MARKING INFORMATION

NOTE: XXXXX = Date Code, Trace Code and Vendor Code.

**XXXXX**

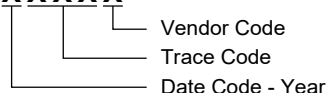

Green (RoHS & HSF): SG Micro Corp defines "Green" to mean Pb-Free (RoHS compatible) and free of halogen substances. If you have additional comments or questions, please contact your SGMICRO representative directly.

ABSOLUTE MAXIMUM RATINGS <sup>(1)</sup>

Supply Voltage Range, $V_{CC}$ .....	-0.5V to 7.0V
Input Voltage Range, $V_I$ <sup>(2)</sup> .....	-0.5V to MIN(7.0V, $V_{CC} + 0.5V$ )
Output Voltage Range, $V_O$ <sup>(2)</sup> .....	-0.5V to MIN(7.0V, $V_{CC} + 0.5V$ )
Input Clamp Current, $I_{IK}$ ( $V_I < -0.5V$ or $V_I > V_{CC} + 0.5V$ ) .....	$\pm 20mA$
Output Clamp Current, $I_{OK}$ ( $V_O < -0.5V$ or $V_O > V_{CC} + 0.5V$ ) .....	$\pm 20mA$
Continuous Output Current, $I_O$ ( $-0.5V < V_O < V_{CC} + 0.5V$ ) .....	$\pm 25mA$
Continuous Current through $V_{CC}$ or GND .....	$\pm 50mA$
Junction Temperature <sup>(3)</sup> .....	+150°C
Storage Temperature Range .....	-65°C to +150°C
Lead Temperature (Soldering, 10s) .....	+260°C
ESD Susceptibility	
HBM .....	6000V
CDM .....	1000V

## RECOMMENDED OPERATING CONDITIONS

Supply Voltage Range, $V_{CC}$ .....	2.0V to 6.0V
Input Voltage Range, $V_I$ .....	0V to $V_{CC}$
Output Voltage Range, $V_O$ .....	0V to $V_{CC}$
Input Transition Rise or Fall Rate, $\Delta t/\Delta V$	
$V_{CC} = 2.0V$ .....	625ns/V (MAX)
$V_{CC} = 4.5V$ .....	139ns/V (MAX)
$V_{CC} = 5.5V$ .....	83ns/V (MAX)
$V_{CC} = 6.0V$ .....	83ns/V (MAX)
Operating Temperature Range .....	-40°C to +125°C

## OVERSTRESS CAUTION

1. Stresses beyond those listed in Absolute Maximum Ratings may cause permanent damage to the device. Exposure to absolute maximum rating conditions for extended periods may affect reliability. Functional operation of the device at any conditions beyond those indicated in the Recommended Operating Conditions section is not implied.
2. The input and output voltage ratings may be exceeded if the input and output clamp current ratings are observed.
3. The performance capability of a high-performance integrated circuit in conjunction with its thermal environment can create junction temperatures which are detrimental to reliability.

## ESD SENSITIVITY CAUTION

This integrated circuit can be damaged if ESD protections are not considered carefully. SGMICRO recommends that all integrated circuits be handled with appropriate precautions. Failure to observe proper handling and installation procedures can cause damage. ESD damage can range from subtle performance degradation to complete device failure. Precision integrated circuits may be more susceptible to damage because even small parametric changes could cause the device not to meet the published specifications.

## DISCLAIMER

SG Micro Corp reserves the right to make any change in circuit design, or specifications without prior notice.

## PIN CONFIGURATIONS

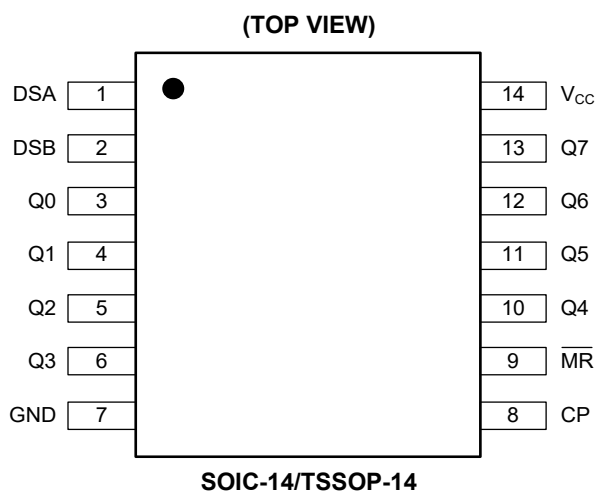

## PIN DESCRIPTION

PIN	NAME	FUNCTION
1	DSA	Serial Data Input A.
2	DSB	Serial Data Input B.
3, 4, 5, 6, 10, 11, 12, 13	Q0, Q1, Q2, Q3, Q4, Q5, Q6, Q7	Parallel Data Outputs.
7	GND	Ground.
8	CP	Clock Input (Low-to-High Clock Transition, Edge-Triggered).
9	$\overline{\text{MR}}$	Master Reset Input (Active-Low).
14	V <sub>CC</sub>	Supply Voltage.

## FUNCTION TABLE

INPUT				OUTPUT	
$\overline{\text{MR}}$	CP	DSA	DSB	Q0	Q1 to Q7
L	X	X	X	L	L to L
H	↑	l	l	L	q0 to q6
H	↑	l	h	L	q0 to q6
H	↑	h	l	L	q0 to q6
H	↑	h	h	H	q0 to q6

H = High voltage level.

h = High voltage level one setup time before clock rising edge ↑.

L = Low voltage level.

l = Low voltage level one setup time before clock rising edge ↑.

q = The state of the referenced output one setup time before clock rising edge ↑.

↑ = Low-to-high clock transition.

X = Don't care.

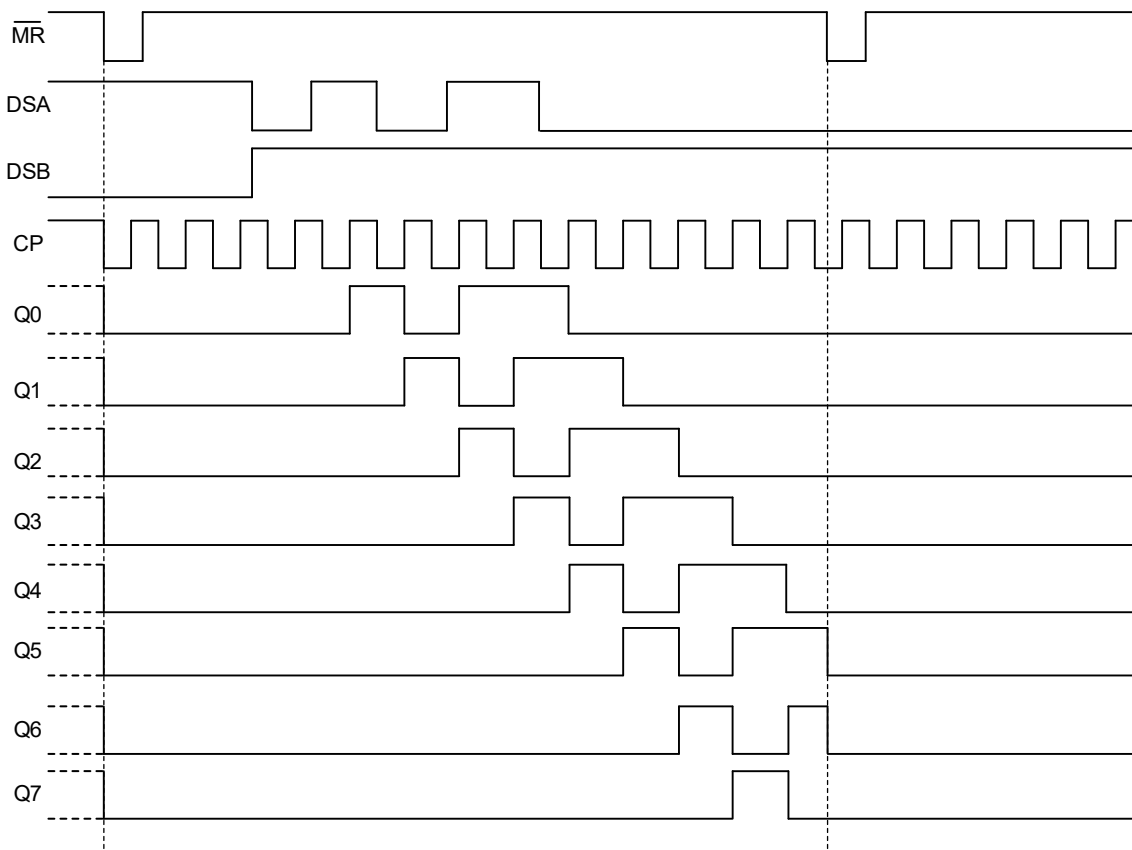

Figure 1. Timing Diagram

**ELECTRICAL CHARACTERISTICS**(Full = -40°C to +125°C, all typical values are measured at T<sub>A</sub> = +25°C, unless otherwise noted.)

PARAMETER	SYMBOL	CONDITIONS	TEMP	MIN	TYP	MAX	UNITS
High-Level Input Voltage	V <sub>IH</sub>	V <sub>CC</sub> = 2.0V	Full	1.50			V
		V <sub>CC</sub> = 4.5V	Full	3.15			
		V <sub>CC</sub> = 5.5V	Full	3.85			
		V <sub>CC</sub> = 6.0V	Full	4.20			
Low-Level Input Voltage	V <sub>IL</sub>	V <sub>CC</sub> = 2.0V	Full			0.50	V
		V <sub>CC</sub> = 4.5V	Full			1.35	
		V <sub>CC</sub> = 5.5V	Full			1.65	
		V <sub>CC</sub> = 6.0V	Full			1.80	
High-Level Output Voltage	V <sub>OH</sub>	V <sub>CC</sub> = 2.0V, I <sub>OH</sub> = -20μA	Full	1.95	1.995		V
		V <sub>CC</sub> = 4.5V, I <sub>OH</sub> = -20μA	Full	4.45	4.495		
		V <sub>CC</sub> = 5.5V, I <sub>OH</sub> = -20μA	Full	5.45	5.495		
		V <sub>CC</sub> = 6.0V, I <sub>OH</sub> = -20μA	Full	5.95	5.995		
		V <sub>CC</sub> = 4.5V, I <sub>OH</sub> = -4.0mA	Full	3.84	4.390		
		V <sub>CC</sub> = 5.5V, I <sub>OH</sub> = -5.2mA	Full	4.84	5.380		
		V <sub>CC</sub> = 6.0V, I <sub>OH</sub> = -5.2mA	Full	5.34	5.880		
Low-Level Output Voltage	V <sub>OL</sub>	V <sub>CC</sub> = 2.0V, I <sub>OL</sub> = 20μA	Full		0.005	0.05	V
		V <sub>CC</sub> = 4.5V, I <sub>OL</sub> = 20μA	Full		0.005	0.05	
		V <sub>CC</sub> = 5.5V, I <sub>OL</sub> = 20μA	Full		0.005	0.05	
		V <sub>CC</sub> = 6.0V, I <sub>OL</sub> = 20μA	Full		0.005	0.05	
		V <sub>CC</sub> = 4.5V, I <sub>OL</sub> = 4.0mA	Full		0.10	0.33	
		V <sub>CC</sub> = 5.5V, I <sub>OL</sub> = 5.2mA	Full		0.12	0.33	
		V <sub>CC</sub> = 6.0V, I <sub>OL</sub> = 5.2mA	Full		0.12	0.33	
Input Leakage Current	I <sub>I</sub>	V <sub>CC</sub> = 6.0V, V <sub>I</sub> = V <sub>CC</sub> or GND	Full			±1	μA
Supply Current	I <sub>CC</sub>	V <sub>CC</sub> = 6.0V, V <sub>I</sub> = V <sub>CC</sub> or GND, I <sub>O</sub> = 0A	Full			10	μA
Input Capacitance	C <sub>I</sub>		+25°C		4		pF

**DYNAMIC CHARACTERISTICS**

(See Figure 2 for test circuit. Full = -40°C to +125°C, all typical values are measured at  $C_L = 50\text{pF}$  and  $T_A = +25^\circ\text{C}$ , unless otherwise noted.)

PARAMETER	SYMBOL	CONDITIONS	TEMP	MIN <sup>(1)</sup>	TYP	MAX <sup>(1)</sup>	UNITS	
Propagation Delay <sup>(2)</sup>	$t_{PD}$	CP to Qn, see Figure 3	$V_{CC} = 2.0\text{V}$	Full	7	30	100	ns
			$V_{CC} = 4.5\text{V}$	Full	4	11	30	
			$V_{CC} = 5.5\text{V}$	Full	3	10	25	
			$V_{CC} = 6.0\text{V}$	Full	3	10	25	
High-to-Low Propagation Delay	$t_{PHL}$	$\overline{\text{MR}}$ to Qn, see Figure 4	$V_{CC} = 2.0\text{V}$	Full	7	24	100	ns
			$V_{CC} = 4.5\text{V}$	Full	4	10	30	
			$V_{CC} = 5.5\text{V}$	Full	4	9	25	
			$V_{CC} = 6.0\text{V}$	Full	4	9	25	
Transition Time <sup>(2)</sup>	$t_T$	See Figure 3	$V_{CC} = 2.0\text{V}$	Full	1.5	17	40	ns
			$V_{CC} = 4.5\text{V}$	Full	0.3	6	18	
			$V_{CC} = 5.5\text{V}$	Full	0.3	4	15	
			$V_{CC} = 6.0\text{V}$	Full	0.3	3	15	
Pulse Width	$t_W$	CP high or low, see Figure 3	$V_{CC} = 2.0\text{V}$	Full	50			ns
			$V_{CC} = 4.5\text{V}$	Full	22			
			$V_{CC} = 5.5\text{V}$	Full	20			
			$V_{CC} = 6.0\text{V}$	Full	20			
		$\overline{\text{MR}}$ low, see Figure 4	$V_{CC} = 2.0\text{V}$	Full	50			
			$V_{CC} = 4.5\text{V}$	Full	22			
			$V_{CC} = 5.5\text{V}$	Full	20			
			$V_{CC} = 6.0\text{V}$	Full	20			
Recovery Time	$t_{REC}$	$\overline{\text{MR}}$ to CP, see Figure 4	$V_{CC} = 2.0\text{V}$	Full	30			ns
			$V_{CC} = 4.5\text{V}$	Full	15			
			$V_{CC} = 5.5\text{V}$	Full	14			
			$V_{CC} = 6.0\text{V}$	Full	14			
Setup Time	$t_{SU}$	DSA, DSB to CP, see Figure 5	$V_{CC} = 2.0\text{V}$	Full	30			ns
			$V_{CC} = 4.5\text{V}$	Full	15			
			$V_{CC} = 5.5\text{V}$	Full	14			
			$V_{CC} = 6.0\text{V}$	Full	14			
Hold Time	$t_H$	DSA, DSB to CP, see Figure 5	$V_{CC} = 2.0\text{V}$	Full	4			ns
			$V_{CC} = 4.5\text{V}$	Full	4			
			$V_{CC} = 5.5\text{V}$	Full	4			
			$V_{CC} = 6.0\text{V}$	Full	4			

**DYNAMIC CHARACTERISTICS (continued)**

(See Figure 2 for test circuit. Full = -40°C to +125°C, all typical values are measured at  $C_L = 50\text{pF}$  and  $T_A = +25^\circ\text{C}$ , unless otherwise noted.)

PARAMETER	SYMBOL	CONDITIONS	TEMP	MIN <sup>(1)</sup>	TYP	MAX <sup>(1)</sup>	UNITS
Maximum Frequency	$f_{\text{MAX}}$	CP, see Figure 3	$V_{\text{CC}} = 2.0\text{V}$	Full	4		MHz
			$V_{\text{CC}} = 4.5\text{V}$	Full	20		
			$V_{\text{CC}} = 5.5\text{V}$	Full	24		
			$V_{\text{CC}} = 6.0\text{V}$	Full	24		
Power Dissipation Capacitance <sup>(3)</sup>	$C_{\text{PD}}$	Per package, $V_I = \text{GND to } V_{\text{CC}}$	+25°C		45		pF

## NOTES:

- Specified by design and characterization, not production tested.
- $t_{\text{PD}}$  is the same as  $t_{\text{PLH}}$  and  $t_{\text{PHL}}$ .  $t_{\text{T}}$  is the same as  $t_{\text{THL}}$  and  $t_{\text{TLH}}$ .
- $C_{\text{PD}}$  is used to determine the dynamic power dissipation ( $P_{\text{D}}$  in  $\mu\text{W}$ ).

$$P_{\text{D}} = C_{\text{PD}} \times V_{\text{CC}}^2 \times f_{\text{DS}} \times N + \Sigma(C_{\text{L}} \times V_{\text{CC}}^2 \times f_{\text{o}})$$

where:

$f_{\text{DS}}$  = Input frequency in MHz.

$f_{\text{o}}$  = Output frequency in MHz.

$f_{\text{CP}} = 2 \times f_{\text{DS}}$

$C_{\text{L}}$  = Output load capacitance in pF.

$V_{\text{CC}}$  = Supply voltage in Volts.

$N$  = Number of inputs switching.

$\Sigma(C_{\text{L}} \times V_{\text{CC}}^2 \times f_{\text{o}})$  = Sum of the outputs.

TEST CIRCUIT

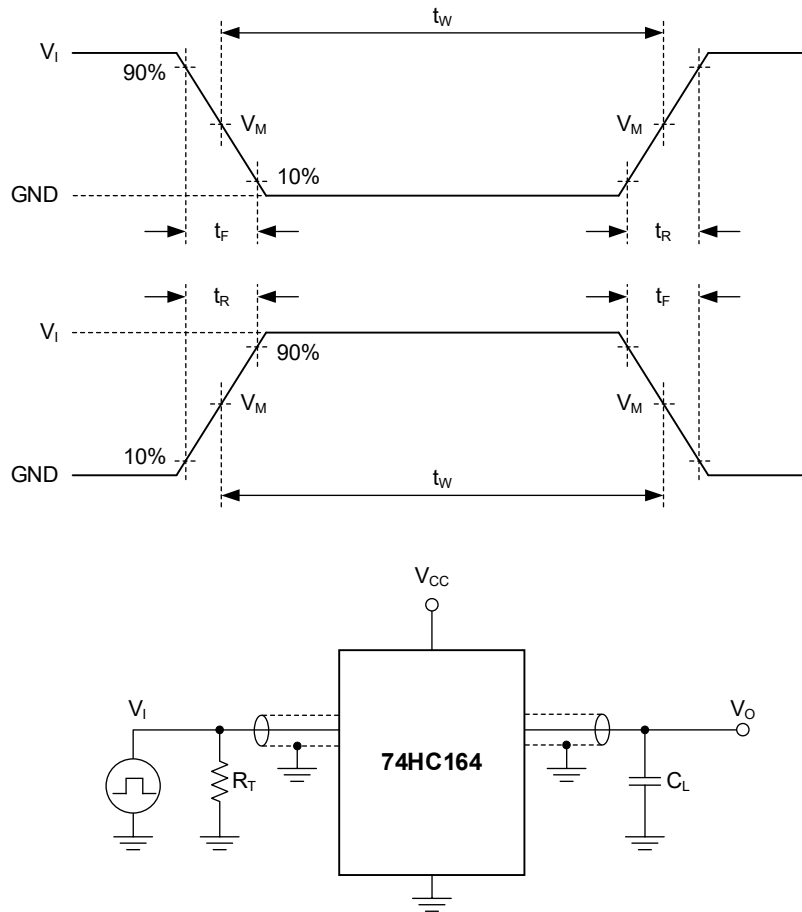

Test conditions are given in Table 1.

Definitions for test circuit:

$C_L$ : Load capacitance (includes jig and probe).

$R_T$ : Termination resistance (equals to output impedance  $Z_O$  of the pulse generator).

Figure 2. Test Circuit for Measuring Switching Times

Table 1. Test Conditions

SUPPLY VOLTAGE	INPUT		LOAD	TEST
$V_{CC}$	$V_I$	$t_R, t_F$	$C_L$	
2.0V to 6.0V	$V_{CC}$	$\leq 6.0ns$	50pF	$t_{PHL}, t_{PLH}$

WAVEFORMS

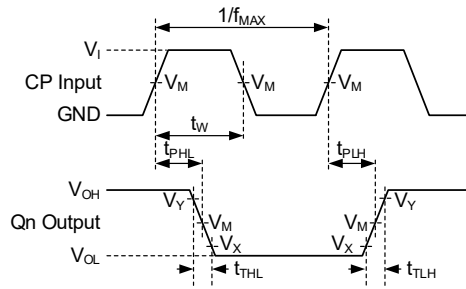

Test conditions are given in Table 1.

Measurement points are given in Table 2.

Logic levels:  $V_{OL}$  and  $V_{OH}$  are typical output voltage levels that occur with the output load

Figure 3. Clock Input to Output Propagation Delays, Clock Pulse Width, Transition Times and Maximum Frequency

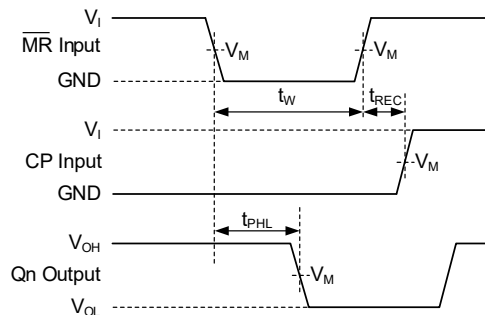

Test conditions are given in Table 1.

Measurement points are given in Table 2.

Logic levels:  $V_{OL}$  and  $V_{OH}$  are typical output voltage levels that occur with the output load.

Figure 4. Master Reset Input to Output Propagation Delays, Pulse Width and Recovery Time

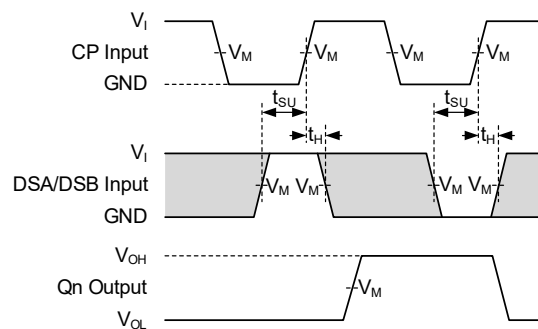

Test conditions are given in Table 1.

Measurement points are given in Table 2.

Logic levels:  $V_{OL}$  and  $V_{OH}$  are typical output voltage levels that occur with the output load.

The shaded areas refer to when the input is allowed to change for predictable output performance.

Figure 5. Data Setup and Hold Times

Table 2. Measurement Points

SUPPLY VOLTAGE		INPUT		OUTPUT		
$V_{CC}$	$V_I$	$V_M^{(1)}$	$V_M$	$V_X$	$V_Y$	
2.0V to 6.0V	$V_{CC}$	$0.5 \times V_{CC}$	$0.5 \times V_{CC}$	$0.1 \times V_{CC}$	$0.9 \times V_{CC}$	

NOTE:

1. The measurement points should be  $V_{IH}$  or  $V_{IL}$  when the input rising or falling time exceeds 6.0ns.

---

## REVISION HISTORY

NOTE: Page numbers for previous revisions may differ from page numbers in the current version.

<b>DECEMBER 2025 – REV.A.1 to REV.A.2</b>		<b>Page</b>
Updated Supply Voltage Range.....	All	All
Updated Package Outline Dimensions section .....	11	11
<b>JULY 2024 – REV.A to REV.A.1</b>		<b>Page</b>
Added Timing Diagram.....	4	4
<b>Changes from Original to REV.A (AUGUST 2023)</b>		<b>Page</b>
Changed from product preview to production data.....	All	All

# PACKAGE INFORMATION

## PACKAGE OUTLINE DIMENSIONS

### SOIC-14

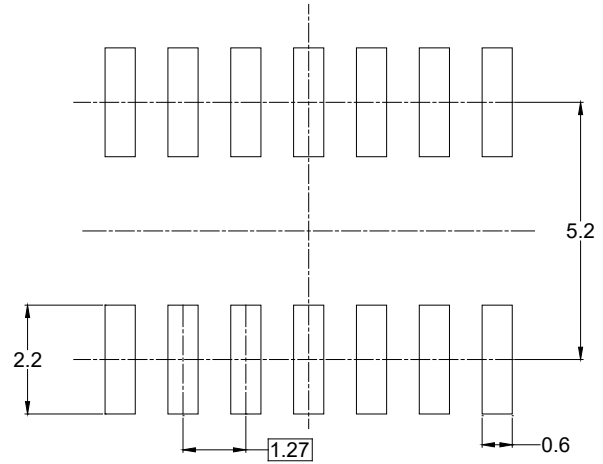
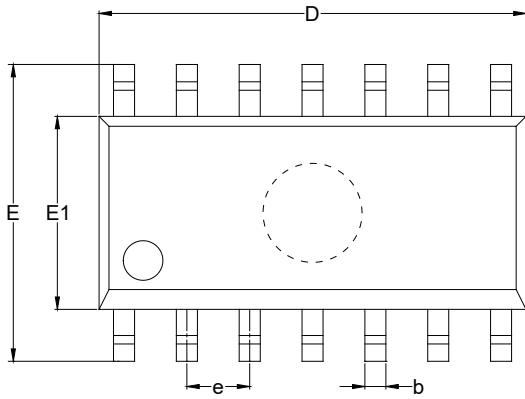

RECOMMENDED LAND PATTERN (Unit: mm)

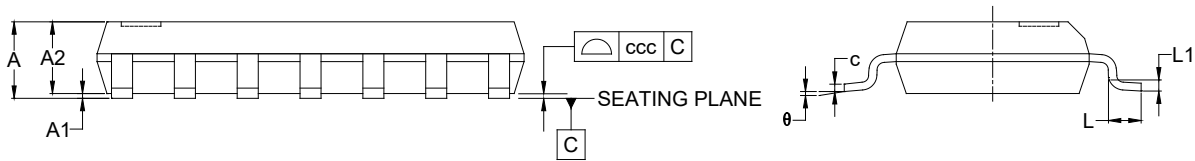

Symbol	Dimensions In Millimeters		
	MIN	NOM	MAX
A	-	-	1.750
A1	0.100	-	0.250
A2	1.250	-	-
b	0.310	-	0.510
c	0.100	-	0.250
D	8.450	-	8.850
E	5.800	-	6.200
E1	3.800	-	4.000
e	1.270 BSC		
L	0.400	-	1.270
L1	0.250 TYP		
$\theta$	0°	-	8°
ccc	0.100		

NOTES:

1. This drawing is subject to change without notice.
2. The dimensions do not include mold flashes, protrusions or gate burrs.
3. Reference JEDEC MS-012.

PACKAGE OUTLINE DIMENSIONS

TSSOP-14

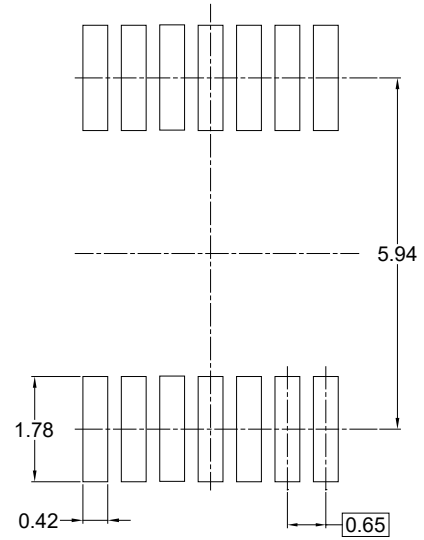
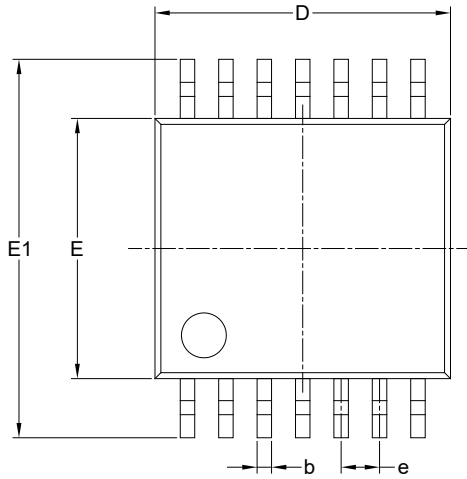

RECOMMENDED LAND PATTERN (Unit: mm)

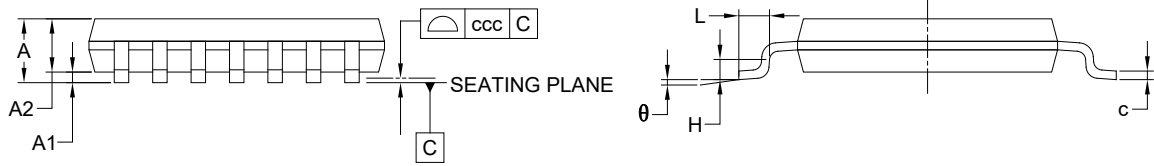

Symbol	Dimensions In Millimeters		
	MIN	NOM	MAX
A	-	-	1.200
A1	0.050	-	0.150
A2	0.800	-	1.050
b	0.190	-	0.300
c	0.090	-	0.200
D	4.860	-	5.100
E	4.300	-	4.500
E1	6.200	-	6.600
e	0.650 BSC		
L	0.450	-	0.750
H	0.250 TYP		
theta	0°	-	8°
ccc	0.100		

NOTES:

1. This drawing is subject to change without notice.
2. The dimensions do not include mold flashes, protrusions or gate burrs.
3. Reference JEDEC MO-153.

TAPE AND REEL INFORMATION

REEL DIMENSIONS

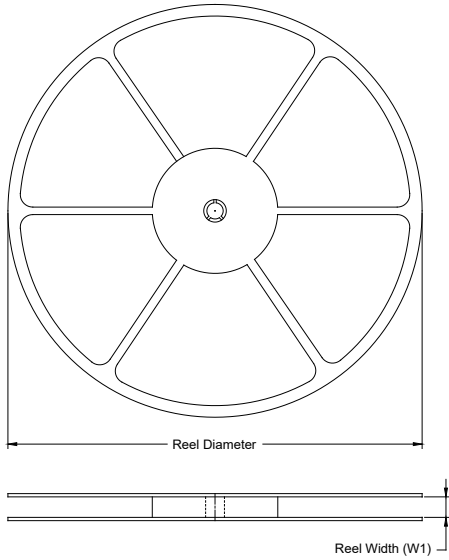

TAPE DIMENSIONS

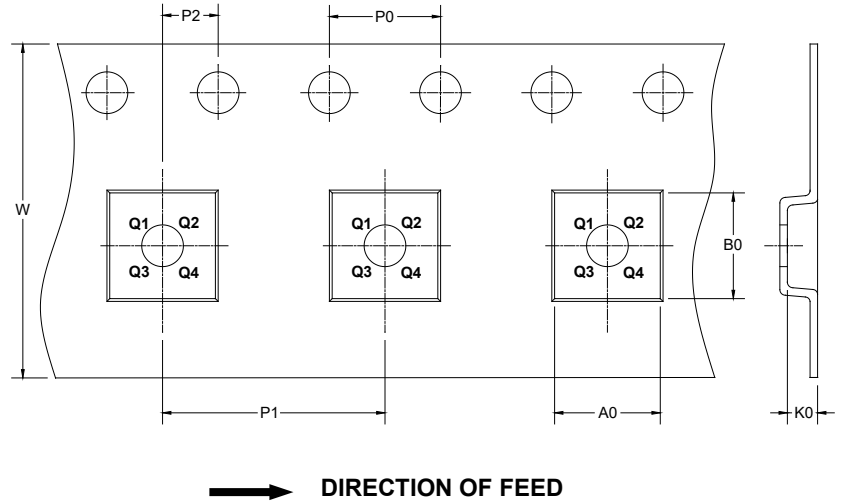

NOTE: The picture is only for reference. Please make the object as the standard.

KEY PARAMETER LIST OF TAPE AND REEL

Package Type	Reel Diameter	Reel Width W1 (mm)	A0 (mm)	B0 (mm)	K0 (mm)	P0 (mm)	P1 (mm)	P2 (mm)	W (mm)	Pin1 Quadrant
SOIC-14	13"	16.4	6.60	9.30	2.10	4.0	8.0	2.0	16.0	Q1
TSSOP-14	13"	12.4	6.80	5.40	1.50	4.0	8.0	2.0	12.0	Q1

DR00001

# PACKAGE INFORMATION

## CARTON BOX DIMENSIONS

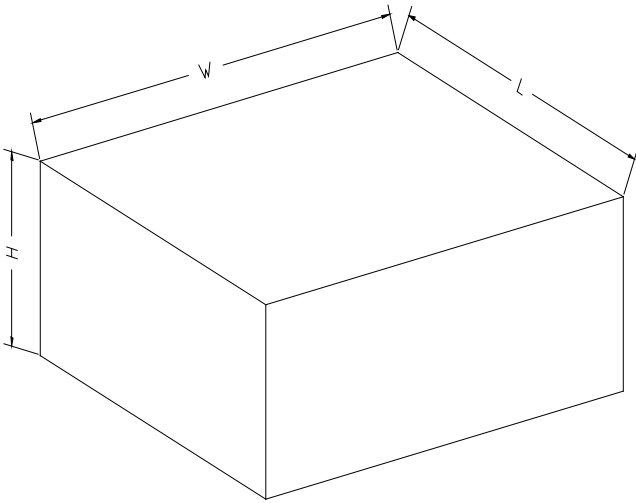

NOTE: The picture is only for reference. Please make the object as the standard.

## KEY PARAMETER LIST OF CARTON BOX

Reel Type	Length (mm)	Width (mm)	Height (mm)	Pizza/Carton
13"	386	280	370	5

DD0002