



# 74AVC4T245Q

## Automotive, 4-Bit Dual-Supply Translating Transceiver with Configurable Voltage Translation and 3-State Outputs

### GENERAL DESCRIPTION

The 74AVC4T245Q is a 4-bit, dual-supply voltage level transceiver with 3-state outputs and bidirectional level translation. The device can be used as two 2-bit transceivers or one 4-bit transceiver. The nAn and nBn are four data input-output ports. nDIR are the direction control inputs and  $\overline{\text{nOE}}$  are the output enable inputs.  $V_{\text{CCA}}$  and  $V_{\text{CCB}}$  are the supply pins. The supply voltage of  $V_{\text{CCA}}$  and  $V_{\text{CCB}}$  can range from 0.8V to 3.6V, making the device suitable for bidirectional translating among any of the 0.8V, 1.2V, 1.5V, 1.8V, 2.5V and 3.3V voltage nodes. The nAn, nDIR and  $\overline{\text{nOE}}$  signals are referenced to  $V_{\text{CCA}}$  and nBn signals are referenced to  $V_{\text{CCB}}$ .

When nDIR is set high, it allows transmission from nAn to nBn. When nDIR is set low, it allows transmission from nBn to nAn.  $\overline{\text{nOE}}$  can be used to make the outputs disabled so that the buses are effectively isolated. In suspend mode, both nAn and nBn are in high-impedance state when either  $V_{\text{CCA}}$  or  $V_{\text{CCB}}$  input is at GND level.

This device is highly suitable for partial power-down applications by using power-off circuit. When the device is powered down, the outputs are disabled, and the current backflow can be prevented from passing through the device.

The device is AEC-Q100 qualified (Automotive Electronics Council (AEC) standard Q100 Grade 1) and it is suitable for automotive applications.

The 74AVC4T245Q is available in Green TSSOP-16, TQFN-3.5×4-16L, TQFN-2.5×3.5-16L and UTQFN-2.6×1.8-16L packages. It operates over a temperature range of -40°C to +125°C.

### FEATURES

- **AEC-Q100 Qualified for Automotive Applications Device Temperature Grade 1**  
 $T_A = -40^\circ\text{C}$  to  $+125^\circ\text{C}$
- **$V_{\text{CCA}}$  Supply Voltage Range: 0.8V to 3.6V**
- **$V_{\text{CCB}}$  Supply Voltage Range: 0.8V to 3.6V**
- **Inputs Accept Voltages Higher than the Supply Voltage and up to 3.6V**
- **Data Rates:**
  - ◆ 380Mbps ( $\geq 1.8\text{V}$  to  $3.3\text{V}$  Translation)
  - ◆ 200Mbps ( $\geq 1.1\text{V}$  to  $3.3\text{V}$  Translation)
  - ◆ 200Mbps ( $\geq 1.1\text{V}$  to  $2.5\text{V}$  Translation)
  - ◆ 200Mbps ( $\geq 1.1\text{V}$  to  $1.8\text{V}$  Translation)
  - ◆ 150Mbps ( $\geq 1.1\text{V}$  to  $1.5\text{V}$  Translation)
  - ◆ 100Mbps ( $\geq 1.1\text{V}$  to  $1.2\text{V}$  Translation)
- **Outputs in High-Impedance State when  $V_{\text{CCA}}$  or  $V_{\text{CCB}} = 0\text{V}$**
- **-40°C to +125°C Operating Temperature Range**
- **Available in Green TSSOP-16, TQFN-3.5×4-16L, TQFN-2.5×3.5-16L and UTQFN-2.6×1.8-16L Packages**

### APPLICATIONS

Automotive Applications  
Personal Electronic Devices  
Enterprise Infrastructures  
Telecom Equipment

# Automotive, 4-Bit Dual-Supply Transceiver with 74AVC4T245Q Configurable Voltage Translation and 3-State Outputs

## PACKAGE/ORDERING INFORMATION

MODEL	PACKAGE DESCRIPTION	SPECIFIED TEMPERATURE RANGE	ORDERING NUMBER	PACKAGE TOP MARKING	PACKING OPTION
74AVC4T245Q	TSSOP-16	-40°C to +125°C	74AVC4T245QTS16G/TR	MEATS16 XXXXX	Tape and Reel, 4000
	TQFN-3.5×4-16L	-40°C to +125°C	74AVC4T245QTUU16G/TR	00X XXXXX	Tape and Reel, 4000
	TQFN-2.5×3.5-16L	-40°C to +125°C	74AVC4T245QTRG16G/TR	00WTRG XXXXX YYYYYY	Tape and Reel, 8000
	UTQFN-2.6×1.8-16L	-40°C to +125°C	74AVC4T245QUSY16G/TR	1H6 XXXXYY	Tape and Reel, 3000

## MARKING INFORMATION

NOTE: XXXXX = Date Code, Trace Code and Vendor Code. XXX = Date Code and Trace Code.

### TSSOP-16/TQFN-3.5×4-16L

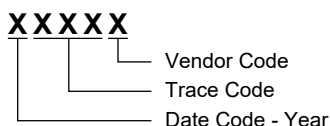

### TQFN-2.5×3.5-16L

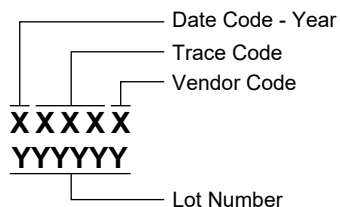

### UTQFN-2.6×1.8-16L

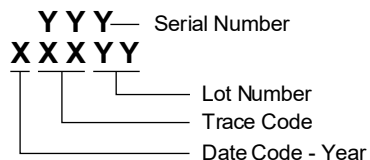

Green (RoHS & HSF): SG Micro Corp defines "Green" to mean Pb-Free (RoHS compatible) and free of halogen substances. If you have additional comments or questions, please contact your SGMICRO representative directly.

# Automotive, 4-Bit Dual-Supply Translating Transceiver with 74AVC4T245Q Configurable Voltage Translation and 3-State Outputs

## ABSOLUTE MAXIMUM RATINGS <sup>(1)</sup>

Supply Voltage Range, $V_{CCA}$ .....	-0.5V to 4.6V
Supply Voltage Range, $V_{CCB}$ .....	-0.5V to 4.6V
Input Voltage Range, $V_I$ <sup>(2)</sup> .....	-0.5V to 4.6V
Output Voltage Range, $V_O$ <sup>(2)</sup>	
Suspend or 3-State Mode .....	-0.5V to 4.6V
Active Mode	
A Ports .....	-0.5V to MIN(4.6V, $V_{CCA} + 0.5V$ )
B Ports .....	-0.5V to MIN(4.6V, $V_{CCB} + 0.5V$ )
Input Clamp Current, $I_{IK}$ ( $V_I < 0V$ ) .....	-50mA
Output Clamp Current, $I_{OK}$ ( $V_O < 0V$ ) .....	-50mA
Continuous Output Current, $I_O$ ( $V_O = 0V$ to $V_{CC}$ ).....	$\pm 50mA$
Continuous Current through $V_{CCA/B}$ or GND.....	$\pm 100mA$
Junction Temperature <sup>(3)</sup> .....	+150°C
Storage Temperature Range .....	-65°C to +150°C
Lead Temperature (Soldering, 10s).....	+260°C
ESD Susceptibility	
HBM.....	6000V
CDM .....	1000V

## RECOMMENDED OPERATING CONDITIONS

Supply Voltage Range, $V_{CCA}$ .....	0.8V to 3.6V
Supply Voltage Range, $V_{CCB}$ .....	0.8V to 3.6V
Input Voltage Range, $V_I$ .....	0V to 3.6V
Output Voltage Range, $V_O$	
Suspend or 3-State Mode .....	0V to 3.6V
Active Mode	
A Ports .....	0V to $V_{CCA}$
B Ports .....	0V to $V_{CCB}$
Input Transition Rise or Fall Rate, $\Delta t/\Delta V$	
$V_{CCI} = 0.8V$ to 3.6V.....	5ns/V (MAX)
Operating Temperature Range .....	-40°C to +125°C

## OVERSTRESS CAUTION

1. Stresses beyond those listed in Absolute Maximum Ratings may cause permanent damage to the device. Exposure to absolute maximum rating conditions for extended periods may affect reliability. Functional operation of the device at any conditions beyond those indicated in the Recommended Operating Conditions section is not implied.
2. The input and output voltage ratings may be exceeded if the input and output clamp current ratings are observed.
3. The performance capability of a high-performance integrated circuit in conjunction with its thermal environment can create junction temperatures which are detrimental to reliability.

## ESD SENSITIVITY CAUTION

This integrated circuit can be damaged if ESD protections are not considered carefully. SGMICRO recommends that all integrated circuits be handled with appropriate precautions. Failure to observe proper handling and installation procedures can cause damage. ESD damage can range from subtle performance degradation to complete device failure. Precision integrated circuits may be more susceptible to damage because even small parametric changes could cause the device not to meet the published specifications.

## DISCLAIMER

SG Micro Corp reserves the right to make any change in circuit design, or specifications without prior notice.

# Automotive, 4-Bit Dual-Supply Translating Transceiver with 74AVC4T245Q Configurable Voltage Translation and 3-State Outputs

## LOGIC DIAGRAM

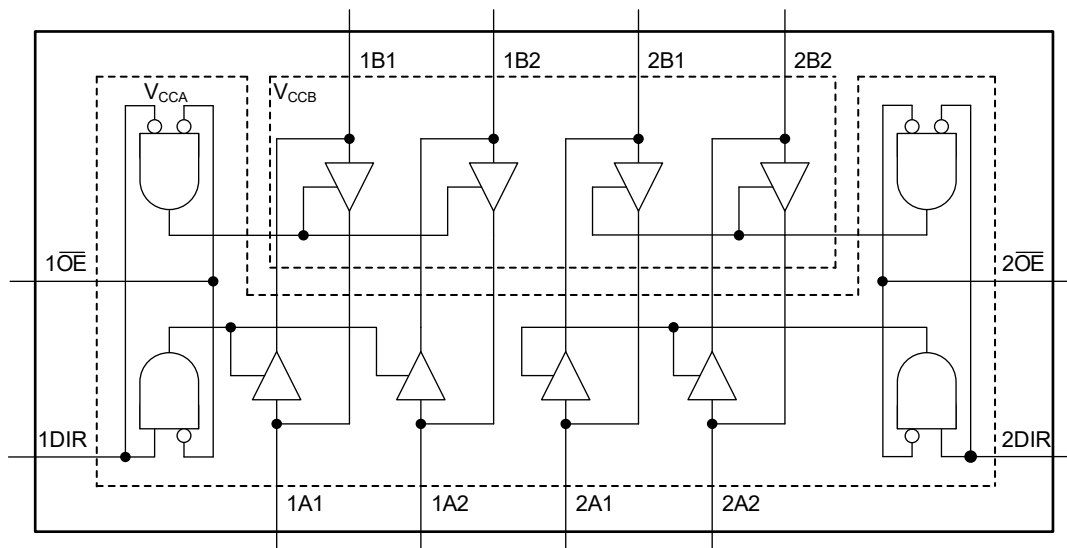

## FUNCTION TABLE

SUPPLY VOLTAGE	CONTROL INPUT		INPUT/OUTPUT	
	$V_{CCA}, V_{CCB}^{(1)}$	$n\overline{OE}$	$nDIR$	$nAn$
0.8V to 3.6V	L	L	$nAn = nBn$	Inputs
0.8V to 3.6V	L	H	Inputs	$nBn = nAn$
0.8V to 3.6V	H	X	Z	Z
GND <sup>(2)</sup>	X	X	Z	Z

H = High Voltage Level

L = Low Voltage Level

Z = High-Impedance State

X = Don't Care

### NOTES:

- The  $nAn$ ,  $nDIR$  and  $n\overline{OE}$  signals are referenced to  $V_{CCA}$ . The  $nBn$  signals are referenced to  $V_{CCB}$ .
- If either  $V_{CCA}$  or  $V_{CCB}$  is at GND level, the device gets into suspend mode.

# Automotive, 4-Bit Dual-Supply Transceiver with 74AVC4T245Q      Configurable Voltage Translation and 3-State Outputs

## PIN CONFIGURATIONS

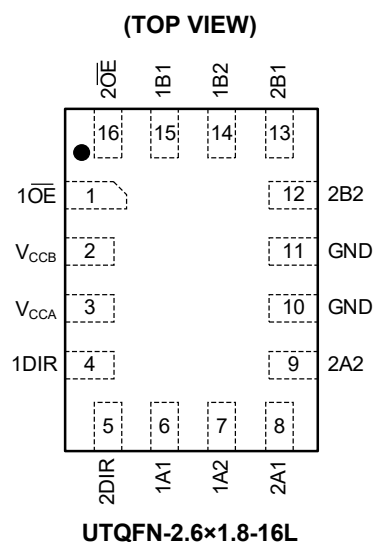
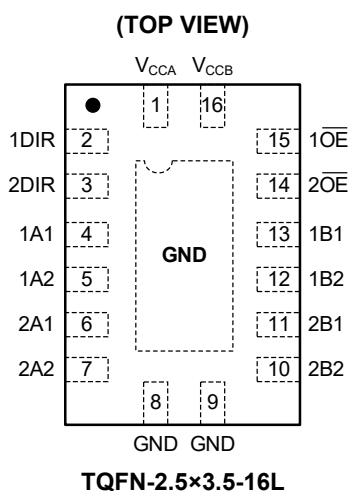
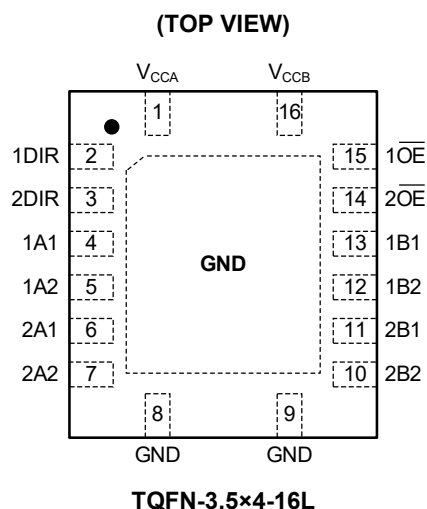
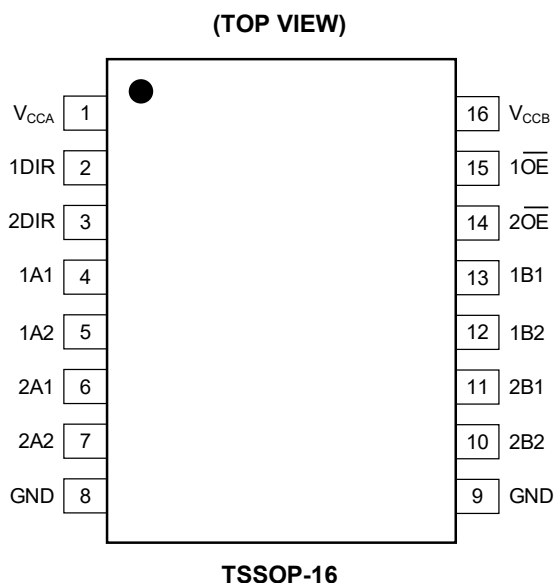

PIN			NAME	FUNCTION
TSSOP-16	TQFN-3.5x4-16L/ TQFN-2.5x3.5-16L	UTQFN-2.6x1.8-16L		
1	1	3	$V_{CCA}$	Supply Voltage $V_{CCA}$ . The nAn, nDIR and nOE signals are referenced to $V_{CCA}$ .
2, 3	2, 3	4, 5	1DIR, 2DIR	Direction Control Inputs.
4, 5	4, 5	6, 7	1A1, 1A2	Data Inputs/Outputs.
6, 7	6, 7	8, 9	2A1, 2A2	Data Inputs/Outputs.
8, 9	8, 9	10, 11	GND	Ground.
11, 10	11, 10	13, 12	2B1, 2B2	Data Inputs/Outputs.
13, 12	13, 12	15, 14	1B1, 1B2	Data Inputs/Outputs.
15, 14	15, 14	1, 16	1OE, 2OE	Output Enable Inputs (Active-Low).
16	16	2	$V_{CCB}$	Supply Voltage $V_{CCB}$ . The nBn signals are referenced to $V_{CCB}$ .
—	Exposed Pad	—	GND	Connect it to GND internally. This pad is not an electrical connection point.

PACKAGE OUTLINE DIMENSIONS

TSSOP-16

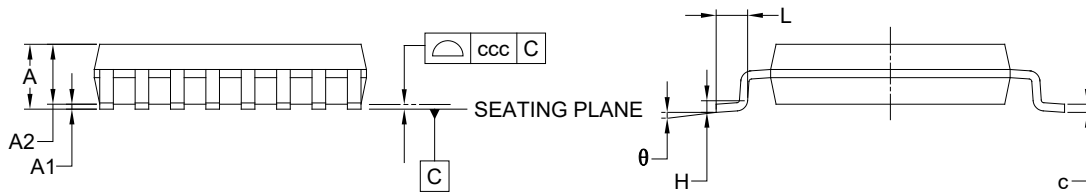
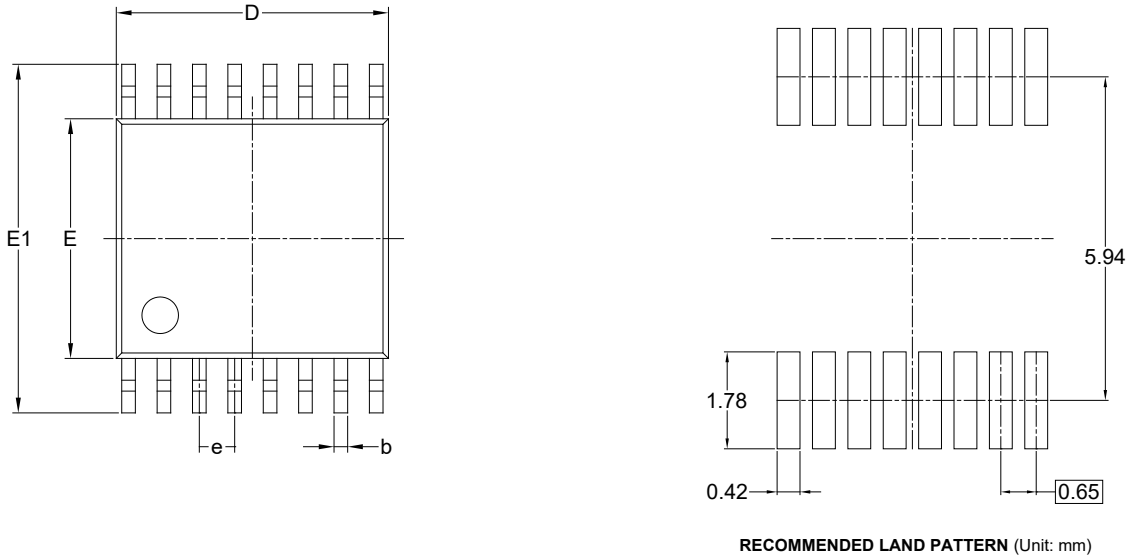

Symbol	Dimensions In Millimeters		
	MIN	NOM	MAX
A	-	-	1.200
A1	0.050	-	0.150
A2	0.800	-	1.050
b	0.190	-	0.300
c	0.090	-	0.200
D	4.860	-	5.100
E	4.300	-	4.500
E1	6.200	-	6.600
e	0.650 BSC		
L	0.450	-	0.750
H	0.250 TYP		
θ	0°	-	8°
ccc	0.100		

- NOTES:
1. This drawing is subject to change without notice.
  2. The dimensions do not include mold flashes, protrusions or gate burrs.
  3. Reference JEDEC MO-153.

PACKAGE OUTLINE DIMENSIONS

TQFN-3.5x4-16L

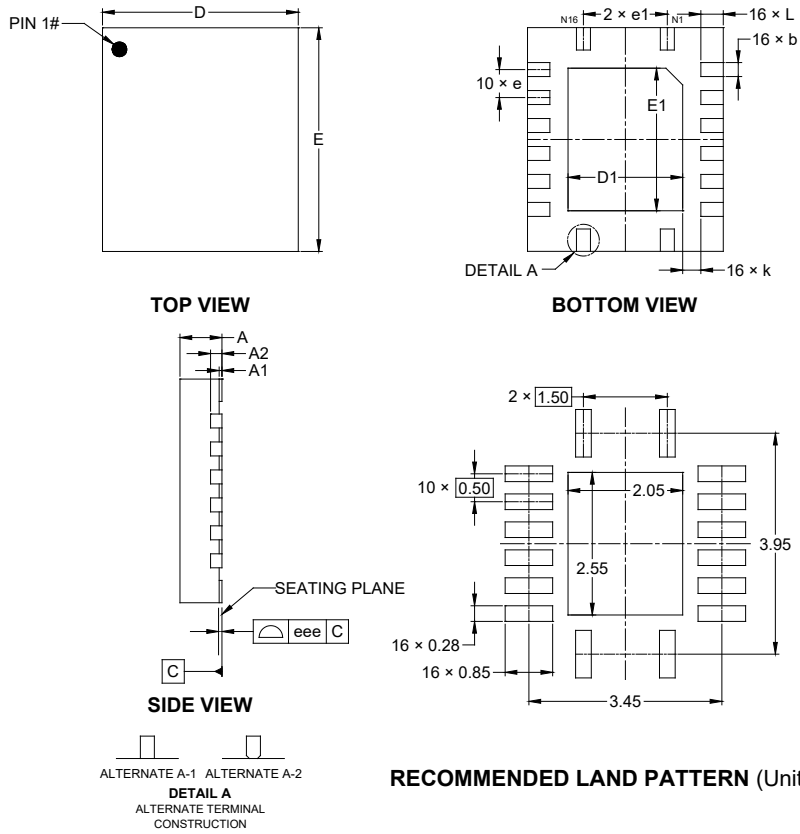

RECOMMENDED LAND PATTERN (Unit: mm)

Symbol	Dimensions In Millimeters		
	MIN	NOM	MAX
A	0.700	-	0.800
A1	0.000	-	0.050
A2	0.203 REF		
b	0.200	-	0.300
D	3.400	-	3.600
E	3.900	-	4.100
D1	1.950	-	2.150
E1	2.450	-	2.650
e	0.500 BSC		
e1	1.500 BSC		
k	0.325 REF		
L	0.300	-	0.500
eee	0.080		

NOTE: This drawing is subject to change without notice.

PACKAGE OUTLINE DIMENSIONS

TQFN-2.5×3.5-16L

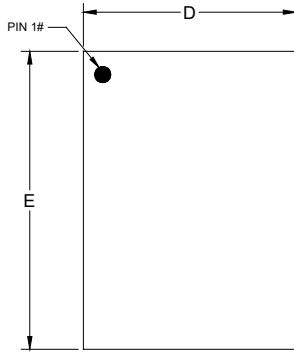

TOP VIEW

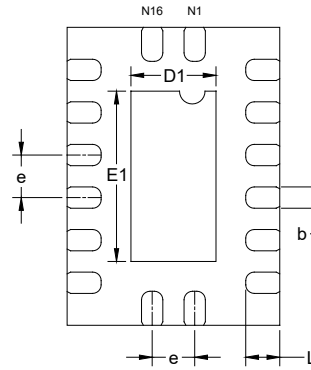

BOTTOM VIEW



SIDE VIEW

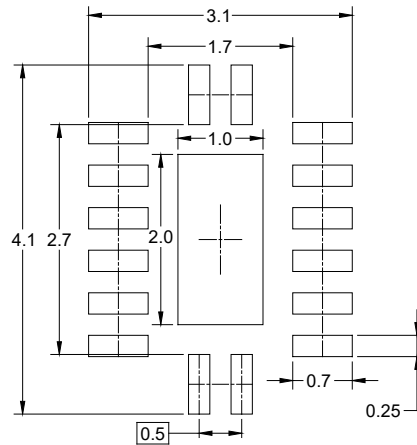

RECOMMENDED LAND PATTERN (Unit: mm)

Symbol	Dimensions In Millimeters		
	MIN	NOM	MAX
A	0.70	0.75	0.80
A1	0.00	0.02	0.05
A2	0.203 REF		
b	0.20	0.25	0.30
D	2.40	2.50	2.60
D1	0.85	1.00	1.15
E	3.40	3.50	3.60
E1	1.85	2.00	2.15
e	0.45	0.50	0.55
L	0.30	0.40	0.50

NOTE: This drawing is subject to change without notice.

PACKAGE OUTLINE DIMENSIONS

UTQFN-2.6x1.8-16L

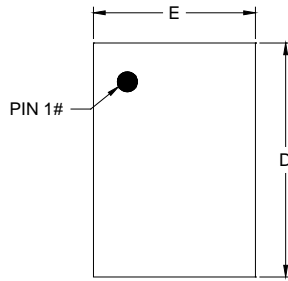

TOP VIEW

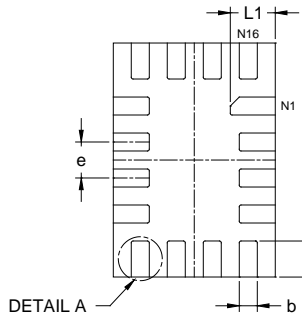

BOTTOM VIEW

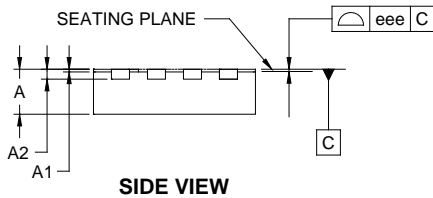

SIDE VIEW

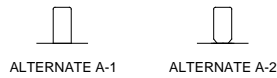

DETAIL A  
ALTERNATE TERMINAL  
CONSTRUCTION

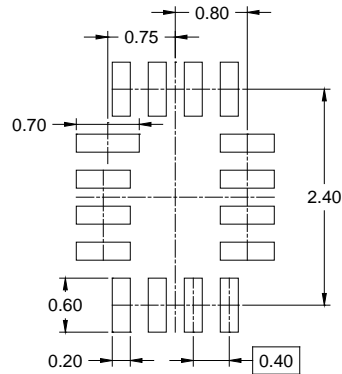

RECOMMENDED LAND PATTERN (Unit: mm)

Symbol	Dimensions In Millimeters		
	MIN	NOM	MAX
A	0.450	-	0.600
A1	-0.004	-	0.050
A2	0.110 REF		
b	0.150	-	0.250
D	2.500	-	2.700
E	1.700	-	1.900
e	0.400 BSC		
L	0.300	-	0.500
L1	0.400	-	0.600
eee	0.050		

NOTE: This drawing is subject to change without notice.

# PACKAGE INFORMATION

## TAPE AND REEL INFORMATION

### REEL DIMENSIONS

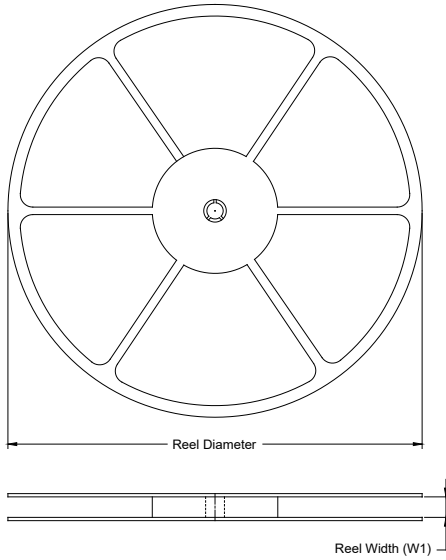

### TAPE DIMENSIONS

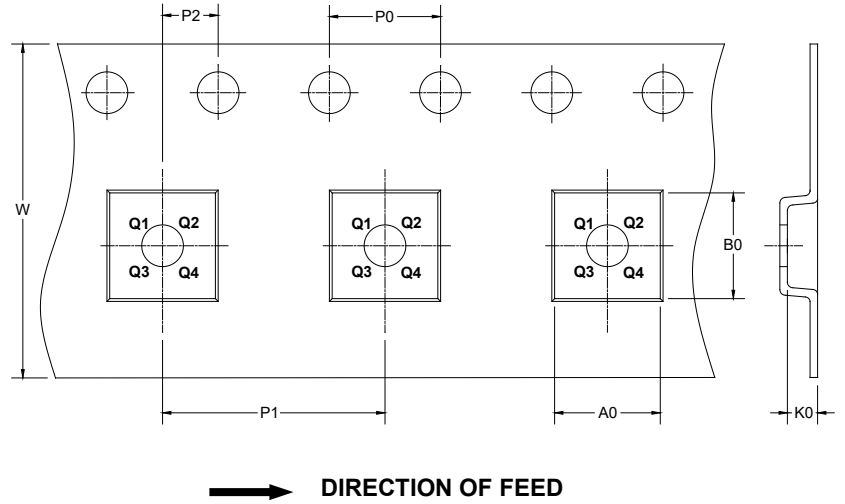

NOTE: The picture is only for reference. Please make the object as the standard.

### KEY PARAMETER LIST OF TAPE AND REEL

Package Type	Reel Diameter	Reel Width W1 (mm)	A0 (mm)	B0 (mm)	K0 (mm)	P0 (mm)	P1 (mm)	P2 (mm)	W (mm)	Pin1 Quadrant
TSSOP-16	13"	12.4	6.80	5.40	1.50	4.0	8.0	2.0	12.0	Q1
TQFN-3.5×4-16L	13"	12.4	3.80	4.30	1.05	4.0	8.0	2.0	12.0	Q1
TQFN-2.5×3.5-16L	13"	12.4	2.80	3.80	1.13	4.0	4.0	2.0	12.0	Q1
UTQFN-2.6×1.8-16L	7"	9.5	2.10	2.90	0.75	4.0	4.0	2.0	8.0	Q1

000001

# PACKAGE INFORMATION

## CARTON BOX DIMENSIONS

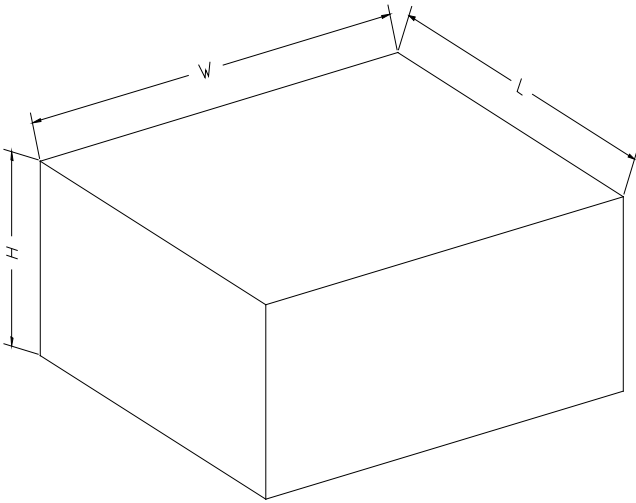

NOTE: The picture is only for reference. Please make the object as the standard.

## KEY PARAMETER LIST OF CARTON BOX

Reel Type	Length (mm)	Width (mm)	Height (mm)	Pizza/Carton
7" (Option)	368	227	224	8
7"	442	410	224	18
13"	386	280	370	5

DD0002