

GENERAL DESCRIPTION

The SGM66155 is an internally compensated, 3MHz switching frequency, current mode, synchronous Boost switching converter. The SGM66155 offers various fixed output voltages, 5V, 5.1V, 5.2V, 5.25V, 5.3V and 5.4V. The SGM66155B/C implements a BYP pin to configure bypass mode when EN pin is pulled to logic low or true disconnect mode. The output voltage is disconnected by the rectifier circuit during shutdown, with no input to output leakage.

The SGM66155 implements valley current mode controls with adaptive on time architecture to regulate the output voltage. Current mode control offers excellent load and line transient performance.

Various protection features such as over-current, short-circuit and over-temperature are implemented to protect the device from various fault conditions.

The SGM66155 is available in a Green WLCSP-1.20×1.21-9B package.

FEATURES

- 1.95V to 5.5V Operating Input Voltage Range
 - ◆ 2.2V Startup Voltage
- 5.0V, 5.1V, 5.2V, 5.25V, 5.3V and 5.4V Fixed Output Voltage
- 17µA (TYP) Quiescent Current
- Up to 95% Efficiency
- 300µs/600µs (TYP) Built-in Soft-Start Time
- 4.5A (TYP) Valley Switch Current Limit
- 1.5A (MIN) Continuous Output Current for $V_{IN} = 3V$, $V_{OUT} = 5.0V$ to 5.4V
- 3MHz (TYP) Switching Frequency
- Selectable Forced PWM or Auto PFM Mode at Light Loads
- Selectable Bypass Mode when $V_{EN} = 0V$
- 5.7V OVP Threshold
- Bypass Mode when $V_{IN} \geq V_{OUT}$
- Input and Output Disconnect when $EN = 0V$
- Hiccup Mode Output Short-Circuit Protection
- Over-Voltage Protection
- Thermal Shutdown Protection
- Available in a Green WLCSP-1.20×1.21-9B Package

APPLICATIONS

- USB OTG
- Boost from Single Cell Li-Ion Battery
- Smart Phones and Tablets
- Portable and Wearable Devices

SIMPLIFIED SCHEMATIC

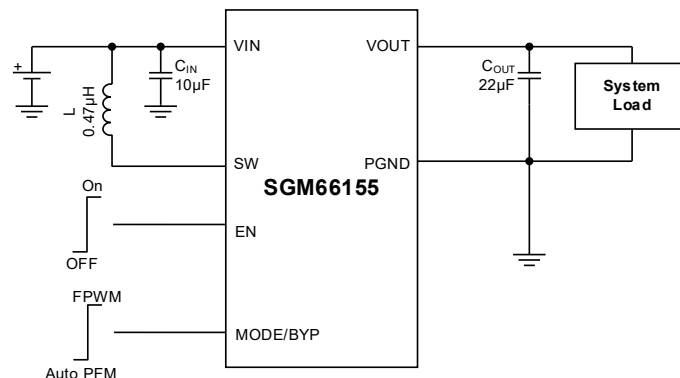

Figure 1. Simplified Schematic

PACKAGE/ORDERING INFORMATION

MODEL	PACKAGE DESCRIPTION	SPECIFIED TEMPERATURE RANGE	ORDERING NUMBER	PACKAGE MARKING	PACKING OPTION
SGM66155-5.0	WLCSP-1.20×1.21-9B	-40°C to +125°C	SGM66155-5.0XG/TR	XXXX 243	Tape and Reel, 3000
SGM66155-5.25	WLCSP-1.20×1.21-9B	-40°C to +125°C	SGM66155-5.25XG/TR	XXXX 286	Tape and Reel, 3000
SGM66155A-5.0	WLCSP-1.20×1.21-9B	-40°C to +125°C	SGM66155A-5.0XG/TR	XXXX 287	Tape and Reel, 3000
SGM66155A-5.1	WLCSP-1.20×1.21-9B	-40°C to +125°C	SGM66155A-5.1XG/TR	XXXX 288	Tape and Reel, 3000
SGM66155A-5.2	WLCSP-1.20×1.21-9B	-40°C to +125°C	SGM66155A-5.2XG/TR	XXXX 27U	Tape and Reel, 3000
SGM66155A-5.3	WLCSP-1.20×1.21-9B	-40°C to +125°C	SGM66155A-5.3XG/TR	XXXX 289	Tape and Reel, 3000
SGM66155A-5.4	WLCSP-1.20×1.21-9B	-40°C to +125°C	SGM66155A-5.4XG/TR	XXXX 28A	Tape and Reel, 3000
SGM66155B-5.0	WLCSP-1.20×1.21-9B	-40°C to +125°C	SGM66155B-5.0XG/TR	XXXX 28B	Tape and Reel, 3000
SGM66155B-5.25	WLCSP-1.20×1.21-9B	-40°C to +125°C	SGM66155B-5.25XG/TR	XXXX 28C	Tape and Reel, 3000
SGM66155C-5.0	WLCSP-1.20×1.21-9B	-40°C to +125°C	SGM66155C-5.0XG/TR	XXXX 2XR	Tape and Reel, 3000
SGM66155C-5.4	WLCSP-1.20×1.21-9B	-40°C to +125°C	SGM66155C-5.4XG/TR	XXXX 32Y	Tape and Reel, 3000

MARKING INFORMATION

NOTE: XXXX = Date Code, Trace Code and Vendor Code.

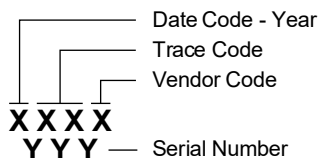

Green (RoHS & HSF): SG Micro Corp defines "Green" to mean Pb-Free (RoHS compatible) and free of halogen substances. If you have additional comments or questions, please contact your SGMICRO representative directly.

DEVICE COMPARISON

Part Number	Output Voltage	C3 Pin	Output Discharge	Soft-Start Time	Over Voltage
SGM66155-5.0	5.0V	Mode	No Discharge	600μs	5.7V
SGM66155-5.25	5.25V	Mode	No Discharge	600μs	5.7V
SGM66155A-5.0	5.0V	Mode	100Ω	300μs	5.7V
SGM66155A-5.1	5.1V	Mode	100Ω	300μs	5.7V
SGM66155A-5.2	5.2V	Mode	100Ω	300μs	5.7V
SGM66155A-5.3	5.3V	Mode	100Ω	300μs	5.7V
SGM66155A-5.4	5.4V	Mode	100Ω	300μs	5.7V
SGM66155B-5.0	5.0V	BYP	No Discharge	600μs	5.7V
SGM66155B-5.25	5.25V	BYP	No Discharge	600μs	5.7V
SGM66155C-5.0	5.0V	nBYP	No Discharge	600μs	5.7V
SGM66155C-5.4	5.4V	nBYP	No Discharge	600μs	5.7V

ABSOLUTE MAXIMUM RATINGS

VIN, VOUT and EN Voltages	-0.3V to 6V
SW Node (DC)	-0.3V to 6V
SW Node (Transient: 10ns, 3MHz)	-1V to 8V
Voltage on Other Pins	-0.3V to 6V
Package Thermal Resistance	
WLCSP-1.20×1.21-9B, θ _{JA}	104.3°C/W
WLCSP-1.20×1.21-9B, θ _{JB}	32.2°C/W
WLCSP-1.20×1.21-9B, θ _{JC}	42.3°C/W
Junction Temperature	+150°C
Storage Temperature Range	-65°C to +150°C
Lead Temperature (Soldering, 10s)	+260°C
ESD Susceptibility ⁽¹⁾⁽²⁾	
HBM	±4000V
CDM	±1000V

NOTES:

- For human body model (HBM), all pins comply with ANSI/ESDA/JEDEC JS-001 specifications.
- For charged device model (CDM), all pins comply with ANSI/ESDA/JEDEC JS-002 specifications.

RECOMMENDED OPERATING CONDITIONS

Input Voltage Range	2.2V to 5.5V
Operating Junction Temperature Range	-40°C to +125°C

OVERSTRESS CAUTION

Stresses beyond those listed in Absolute Maximum Ratings may cause permanent damage to the device. Exposure to absolute maximum rating conditions for extended periods may affect reliability. Functional operation of the device at any conditions beyond those indicated in the Recommended Operating Conditions section is not implied.

ESD SENSITIVITY CAUTION

This integrated circuit can be damaged if ESD protections are not considered carefully. SGMICRO recommends that all integrated circuits be handled with appropriate precautions. Failure to observe proper handling and installation procedures can cause damage. ESD damage can range from subtle performance degradation to complete device failure. Precision integrated circuits may be more susceptible to damage because even small parametric changes could cause the device not to meet the published specifications.

DISCLAIMER

SG Micro Corp reserves the right to make any change in circuit design, or specifications without prior notice.

PIN CONFIGURATIONS

SGM66155/SGM66155A (TOP VIEW)

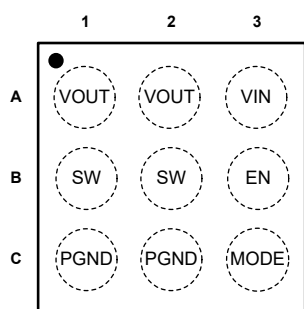

WLCSP-1.20x1.21-9B

SGM66155B/C (TOP VIEW)

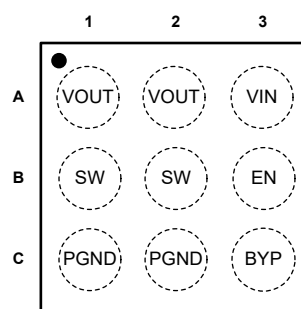

WLCSP-1.20x1.21-9B

PIN DESCRIPTION

PIN	NAME	FUNCTION
A1, A2	VOUT	Boost Converter Output.
A3	VIN	Power Supply Input.
B1, B2	SW	Switching Node. Drain connection of low-side power MOSFET.
B3	EN	Device Enable Node. Pulling this pin logic high enables the device and pulling it logic low disables the device.
C1, C2	PGND	Power Ground.
C3	MODE	Mode Selection Pin. Logic high for forced PWM operation and logic low for auto PFM operation at light loads.
	BYP	Bypass Selection Pin. When EN is logic low, SGM66155Bx with logic high for bypass, and logic low for true disconnect. SGM66155Cx with logic low for bypass, and logic high for true disconnect.

3MHz, 5.0V to 5.4V Fixed Output Synchronous Boost Converter with 4.5A Switch

SGM66155

ELECTRICAL CHARACTERISTICS

($T_J = -40^{\circ}\text{C}$ to $+125^{\circ}\text{C}$, $V_{IN} = 2.2\text{V}$ to 5.5V , typical values are measured at $T_J = +25^{\circ}\text{C}$ and $V_{IN} = 3.6\text{V}$, unless otherwise noted.)

PARAMETER	SYMBOL	CONDITIONS	MIN	TYP	MAX	UNITS
DC/DC Stage						
Input Voltage	V_{IN}		1.95		5.5	V
UVLO Rising Threshold	V_{UVLO_R}		2.0	2.1	2.2	V
UVLO Falling Threshold	V_{UVLO_F}		1.80	1.87	1.95	V
UVLO Hysteresis Voltage	V_{UVLO_HYS}			230		mV
Switching Frequency	f_{SW}			3		MHz
Switch Current Limit	I_L		3.9	4.5	5.1	A
DC Startup Current Limit	I_{LIM_DC}		1.3	2.2		A
Boost Switch On-Resistance	R_{DSON}			25	51	m Ω
Rectifying Switch On-Resistance	R_{DSON}			50	75	m Ω
Soft-Start Time	T_{SS}	SGM66155/SGM66155B/C		600		μs
		SGM66155A		300		
DC Output Voltage Accuracy	V_{OUT}	PWM operation	-1		1	%
Over Voltage Threshold	V_{OVP}			5.7		V
Output Discharge	R_{DIS}	SGM66155A		100		Ω
Quiescent Current into VIN at SD BYP	$I_{Q_BYP_VIN}$	SGM66155B		11		μA
SD BYP Current Limit	$I_{LIM_DC_BYP}$	SGM66155B		170		mA
Quiescent Current into VIN Pin	I_Q	$V_{EN} = V_{IN} = 3.6\text{V}$, $V_{MODE} = 0\text{V}$, no switching, $T_J = -40^{\circ}\text{C}$		17	50	μA
Quiescent Current into VOUT Pin	I_{Q_VOUT}	to $+85^{\circ}\text{C}$		6	15	μA
Shutdown Current	I_{SD}	$V_{EN} = 0\text{V}$, $V_{IN} = 3.6\text{V}$, $T_J = -40^{\circ}\text{C}$ to $+85^{\circ}\text{C}$		0.1	1	μA
Control Stage						
EN and MODE/BYP Input High Voltage Threshold	V_{IH}		0.75			V
EN and MODE/BYP Input Low Voltage Threshold	V_{IL}				0.4	V
EN and Mode/BYP Pull-Down Resistor				850		k Ω
EN and Mode/BYP Input Current		Clamped to GND or VIN		0.01		μA
Over-Temperature Protection	T_{SD}			150		$^{\circ}\text{C}$
Over-Temperature Hysteresis	T_{SD_HYS}			20		$^{\circ}\text{C}$

TYPICAL PERFORMANCE CHARACTERISTICS

At $T_A = +25^\circ\text{C}$, $V_{IN} = 3.6\text{V}$, $V_{OUT} = 5\text{V}$, unless otherwise noted.

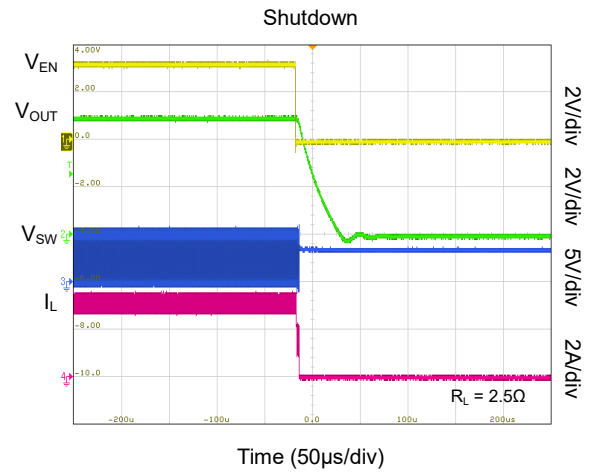
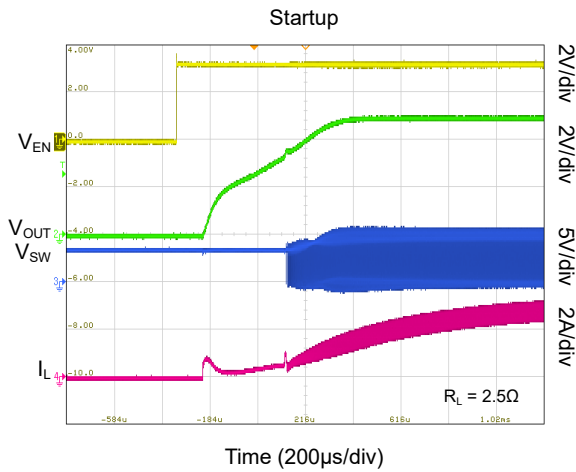
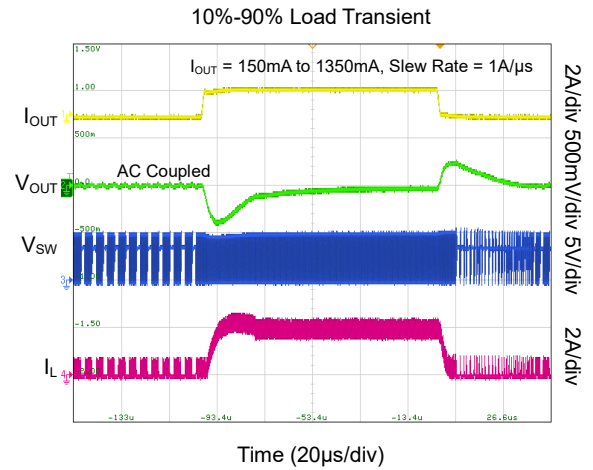
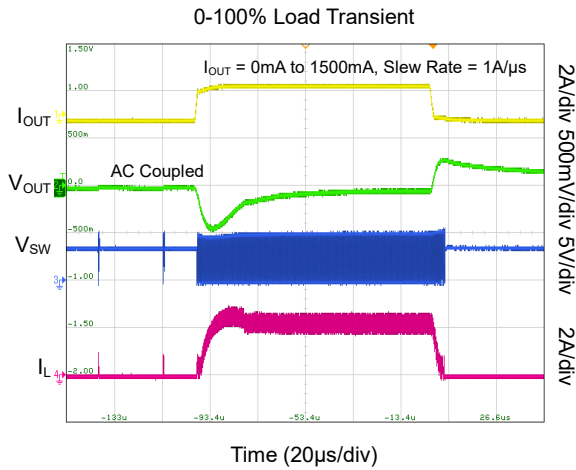
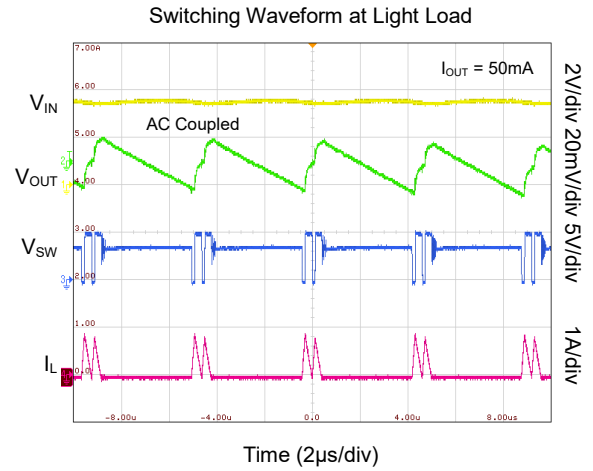
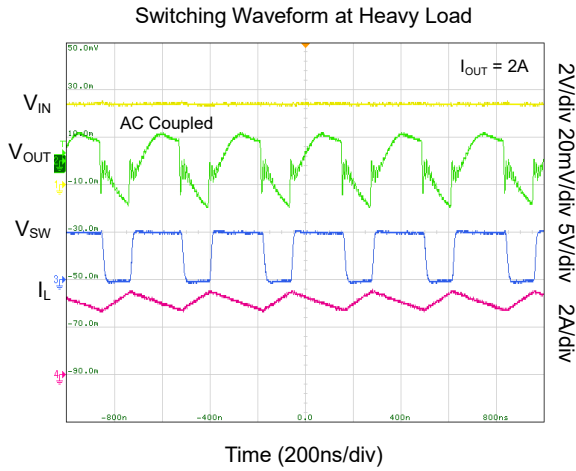

TYPICAL PERFORMANCE CHARACTERISTICS (continued)

At $T_A = +25^\circ\text{C}$, $V_{IN} = 3.6\text{V}$, $V_{OUT} = 5\text{V}$, unless otherwise noted.

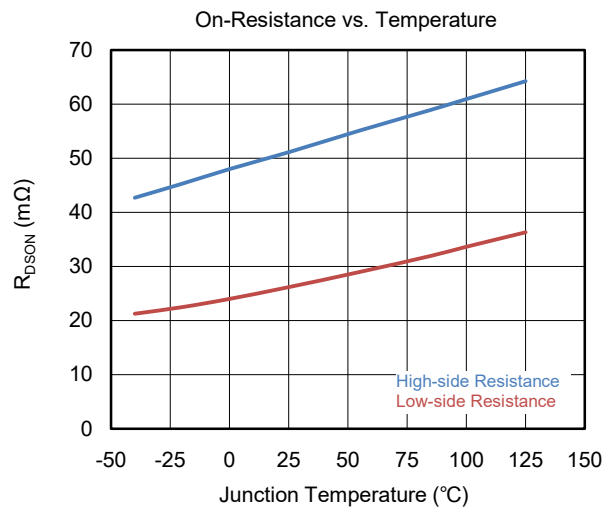
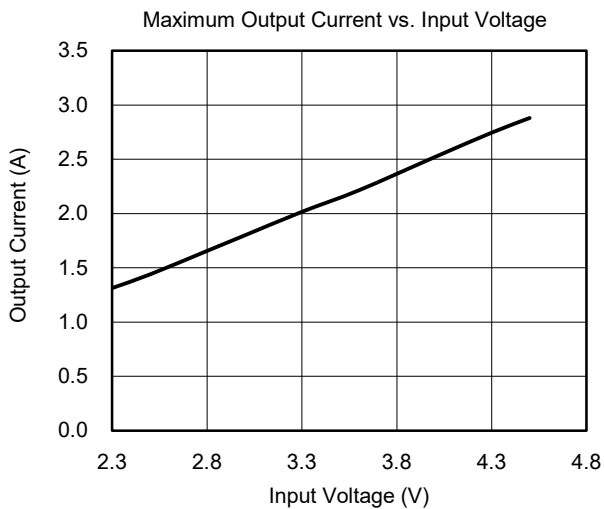
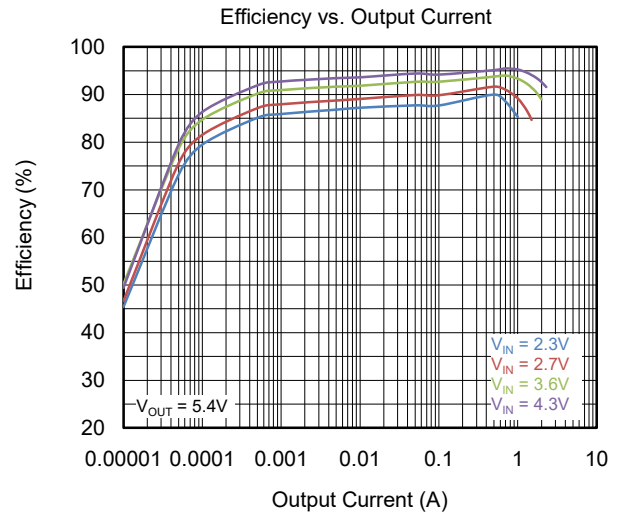
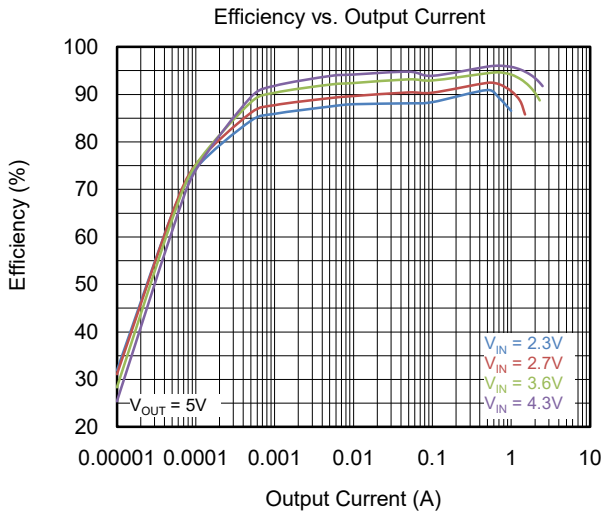
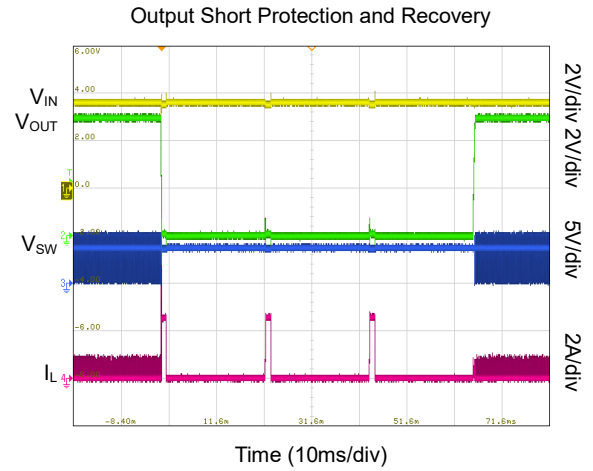
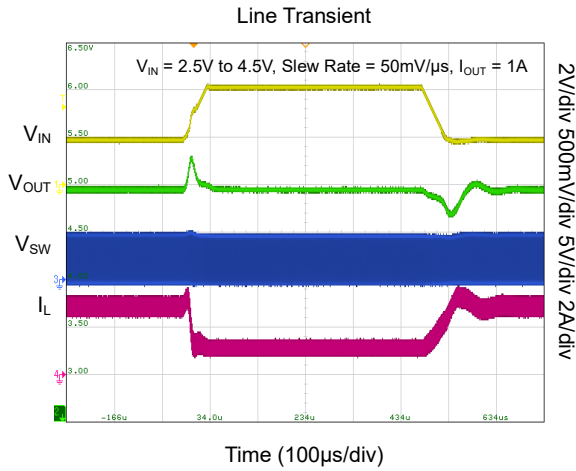

TYPICAL PERFORMANCE CHARACTERISTICS (continued)

At $T_A = +25^\circ\text{C}$, $V_{IN} = 3.6\text{V}$, $V_{OUT} = 5\text{V}$, unless otherwise noted.

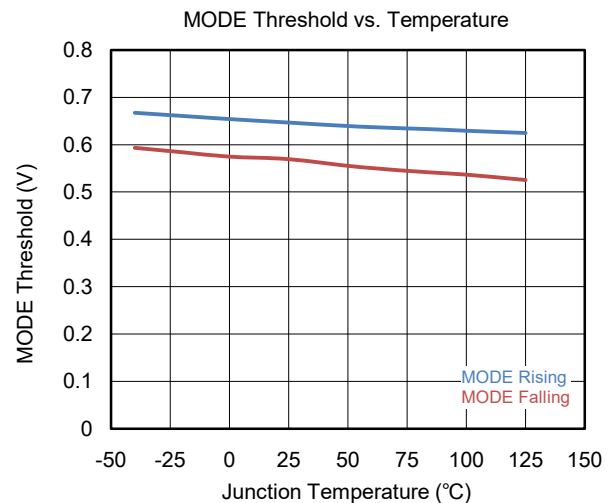
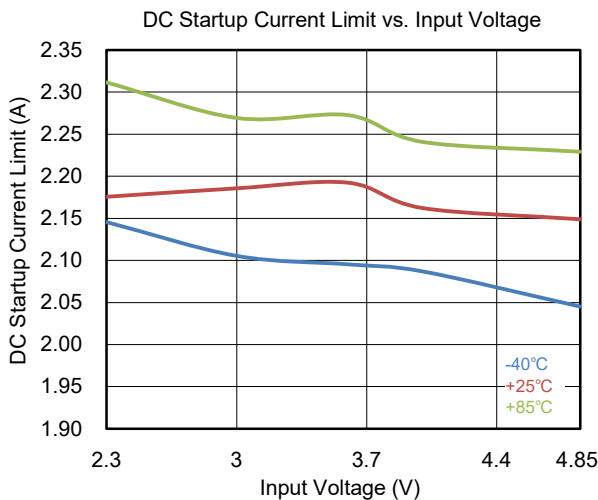
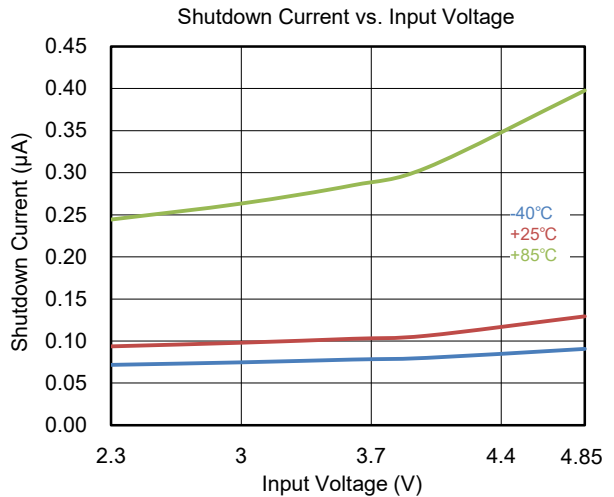
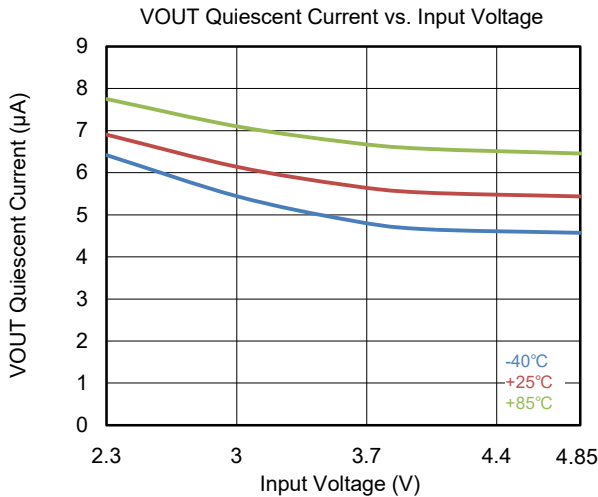
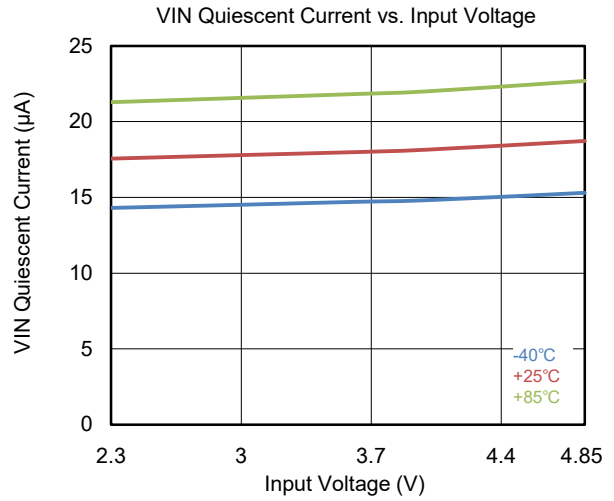
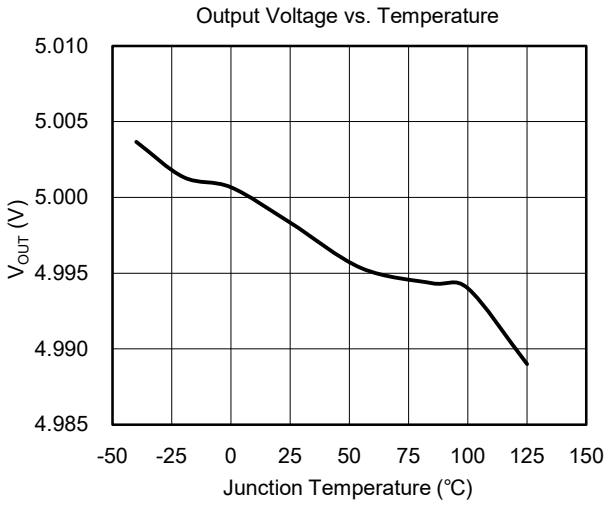

TYPICAL PERFORMANCE CHARACTERISTICS (continued)

At $T_A = +25^\circ\text{C}$, $V_{IN} = 3.6\text{V}$, $V_{OUT} = 5\text{V}$, unless otherwise noted.

BYP Threshold vs. Temperature

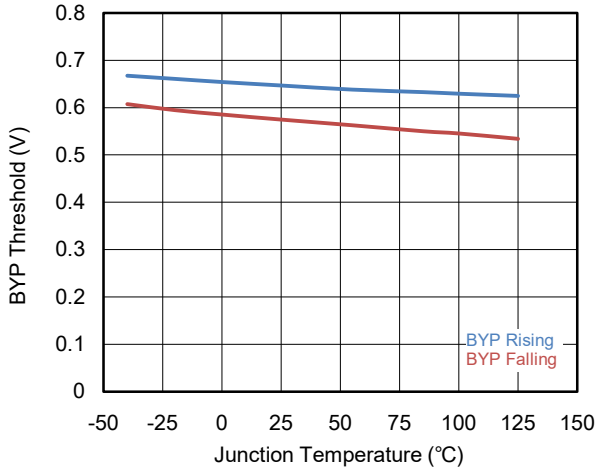

EN Threshold vs. Temperature

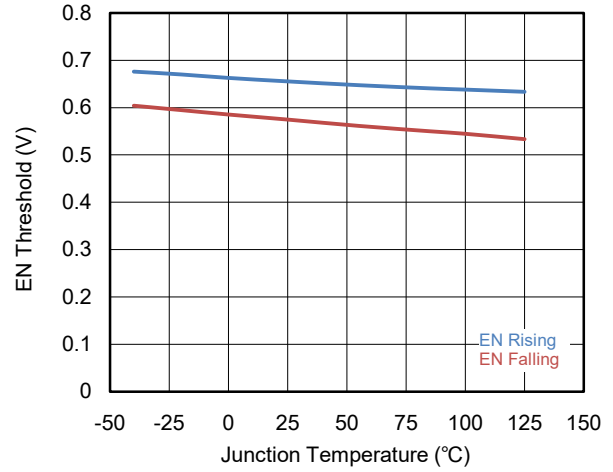

VIN UVLO vs. Temperature

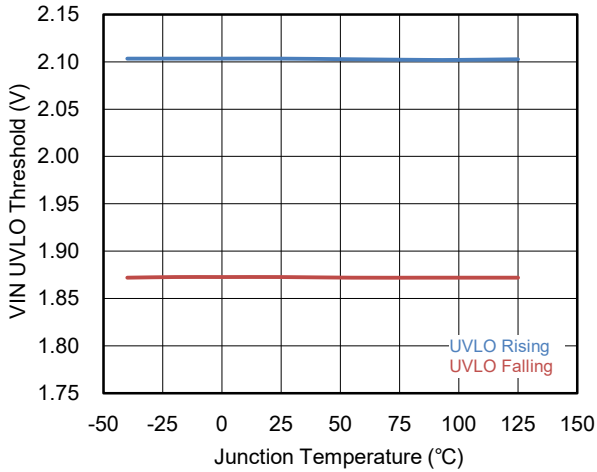

FUNCTIONAL BLOCK DIAGRAM

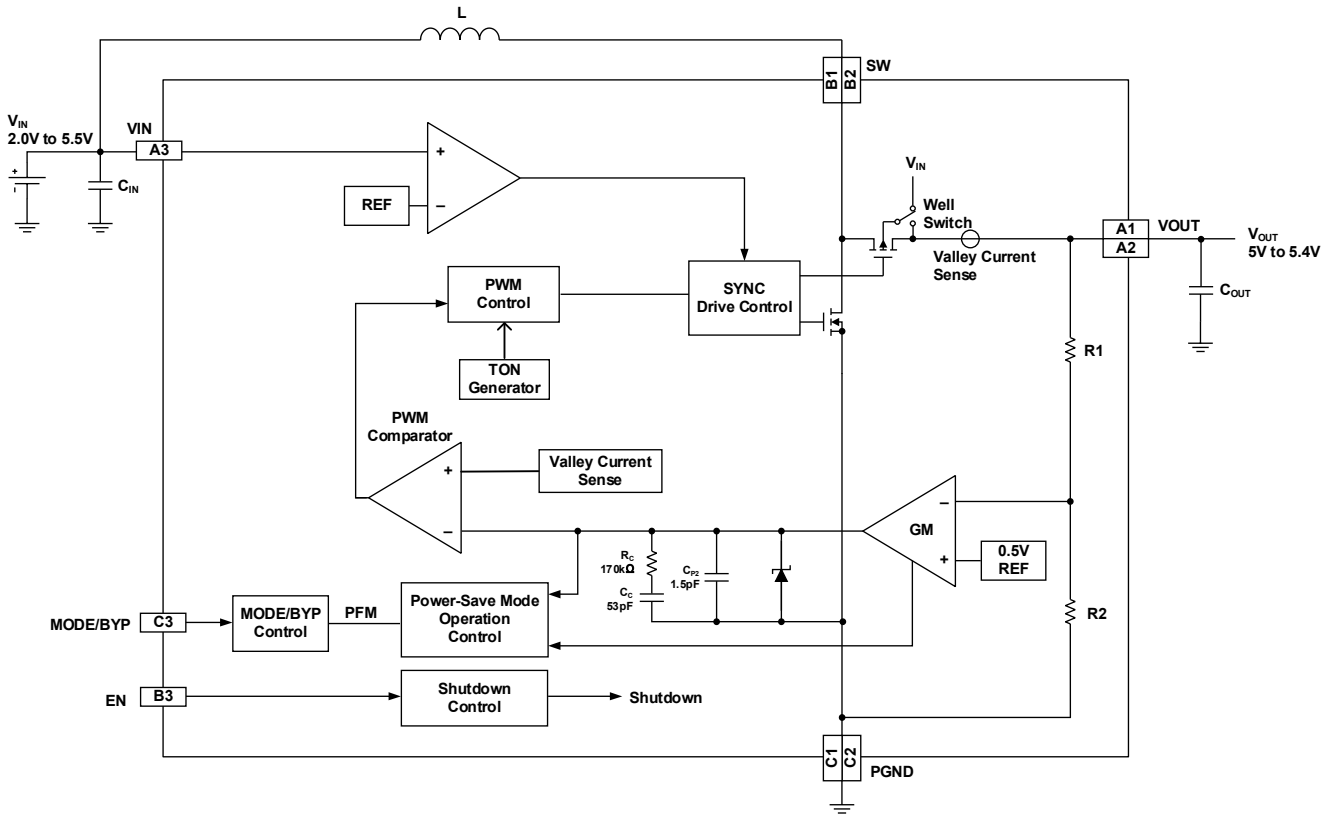

Figure 2. SGM66155 Block Diagram

APPLICATION INFORMATION

The SGM66155 is a fully-integrated synchronous Boost DC/DC converter. The recommended input supply voltage for full performance is 2.0V to 5.5V. An inductor, an output storage capacitor and an input decoupling capacitor should be selected to ensure the proper performance desired in a specific application circuit. The SGM66155/SGM66155A offer MODE configuration for FPWM operation or light load PFM operation. The SGM66155B offers BYP configuration for input to output bypass when BYP is pulled to logic high and EN pin is pulled to logic low.

Startup and Enable

The SGM66155 implements the enable input to control the turn-on and turn-off of the device. A logic signal above 0.75V applied on EN pin turns on the device, and a logic signal below 0.4V turns off the device.

The SGM66155 has built-in 600 μ s (TYP) or 300 μ s (TYP) soft-start time. After enabling, the SGM66155 turns on the high-side rectifier and enters linear pre-charge phase with a limited current of 2A (TYP). As the output voltage reaches the input voltage, the pre-charge phase terminates, and then the device enters the soft-start phase, starts switching and boosts the output voltage to the fixed output. This startup sequence effectively reduces the inrush current during startup.

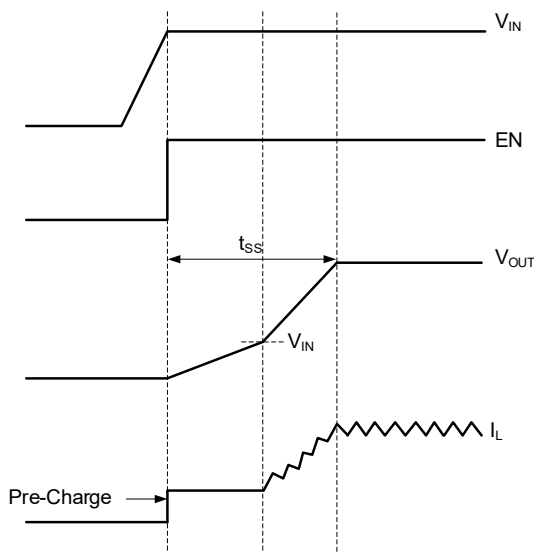

Figure 3. Startup Sequence

The SGM66155 has a built-in 0.01 μ A (TYP) pull-down current when the EN pin is programmed to logic low. In addition to this pull-down current, there is an additional 850k Ω pull-down resistor when EN pin is logic low.

When EN pin is programmed to logic high, the 850k Ω pull-down resistor is switched off and only the 0.01 μ A (TYP) pull-down current remains.

MODE (SGM66155/SGM66155A Only)

The SGM66155/SGM66155A implement MODE pin to configure light load operation. When the MODE pin is pulled to logic low, the device operates in auto PFM mode to maximize efficiency at light load. When the MODE pin is pulled to logic high, the device operates in FPWM mode with a constant switching frequency throughout the entire operating load range.

Auto Power-Save Mode

The SGM66155 implements auto power-save mode (PSM) at light load to maximize the efficiency. As the load current reduces, and valley current triggers the PSM threshold, the device enters PSM operation. The SGM66155 implements advanced PSM mode to reduce the output voltage ripple at light load, as shown in Figure 4 below, the device's frequency varies as the load current varies under PSM.



Figure 4. Power-Save Mode

Bypass Mode (SGM66155B/C Only)

The SGM66155B/C implements bypass mode when pulling the EN pin to logic low and BYP pin to logic high (SGM66155B) or BYP pin to logic low (SGM66155C) to allow the input voltage bypass to the output. When bypass mode is enabled, EN is pulled to logic low, the SGM66155B/C limits the current to 170mA (TYP) as the start-up pre-charge current limit, and the device consumes 11 μ A (TYP) of quiescent current in this mode. Pulling BYP pin to logic low (SGM66155B), or BYP pin to logic high (SGM66155C), the device remains in true disconnect when pulling EN pin to logic low.

Bypass Mode EN = High

When the input voltage is higher than $V_{OUT} + 0.1V$ and output voltage is higher than the nominal output voltage, the device automatically enters bypass mode where the high-side MOSFET turns on completely to pass the input to the output. If the load current exceeds the 2A (TYP) pre-charge current in bypass mode for more than 1ms, the device enters hiccup protection mode.

APPLICATION INFORMATION (continued)

Over-Voltage Protection

The SGM66155 family offers output over voltage protection. When the output voltage exceeds the 5.7V (TYP) OVP threshold, the device stops switching immediately, when the output voltage drops below the (OVP threshold-50mV), the device resumes operation.

Current Limit and Short-Circuit

The SGM66155 has a built-in 4.5A (TYP) valley switch current limit. When inductor current exceeds the valley current limit, output voltage will fall to maintain a constant power operation. As output voltage drops below the input voltage, current limit is reduced to 2A (TYP) to minimize excessive power dissipation within the IC.

When an output short to ground event occurs, the SGM66155 enters the hiccup protection mode. During hiccup mode, the device turns on the high-side rectifier for 1ms with 2A (TYP) current limit, then turns off for 20ms (TYP), this cycle repeats if output remains short, refer to Figure 5 below:

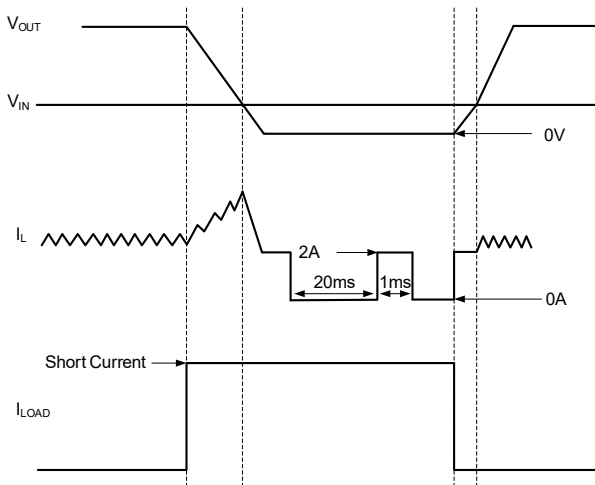

Figure 5. Short-Circuit Protection and Recovery

If the hiccup cycle continues for consecutive 5 seconds, the device stops switching, by toggling the EN pin will restart the device.

When the output short condition is removed within 5 seconds of hiccup cycle, the device resumes operation and enters the soft-start phase.

Inductor Selection

Inductor is an essential element for current DC/DC switch mode power supplies regardless of topology.

Inductor serves as the energy storage element for power conversion. Inductance and saturation current of inductor are two most important criterions for inductor selection. For general design guidance, the selected inductance should provide a peak to peak ripple current that is around 30% of the average inductor current at full load and nominal input voltage. The average inductor current for a Boost converter is the input current. Equation 1 shows the calculation of inductance selection, where f_{SW} is the switching frequency and ΔI_L is the inductor ripple current.

$$L = \frac{V_{IN} \times (V_{OUT} - V_{IN})}{\Delta I_L \times f_{SW} \times V_{OUT}} \quad (1)$$

The 4.5A (TYP) valley current limit and the inductor current ripple should be considered when selecting the saturation current of the inductor.

The inductor also affects the close loop response of the DC/DC converter. The SGM66155 is an internally compensated device, and the loop response is optimized for inductor in the range of 0.33 μ H to 1 μ H.

Input Capacitor

Boost converter's input capacitor has continuous current throughout the entire switching cycle, a 10 μ F ceramic capacitor is recommended to place as close as possible between the VIN pin and GND pin of the device. For applications where the SGM66155 is located far away from the input source, a 47 μ F or higher capacitance capacitor is recommended to damp the wiring harness inductance.

Output Capacitor

The output capacitors of Boost converter dictate the output voltage ripple and load transient response. Equation 2 is used to estimate the necessary capacitance to achieve desired output voltage ripple, where ΔV is the maximum allowed ripple.

$$C_{MIN} = \frac{I_{OUT} \times (V_{OUT} - V_{IN})}{f_{SW} \times \Delta V \times V_{OUT}} \quad (2)$$

Since SGM66155 is an internally compensated device, the loop response is optimized for capacitor in the range of 10 μ F to 47 μ F. Due to the DC bias nature of ceramic capacitors, care should be taken by verifying manufacturer's datasheet to ensure enough effective capacitance at desired output voltage.

APPLICATION INFORMATION (continued)

Layout Considerations

In addition to component selection, layout is a critical step to ensure the performance of any switch mode power supplies. Poor layout could result in system instability, EMI failure, and device damage. Thus, place the inductor, input and output capacitors as close to the IC as possible, and use wide and short traces for current carrying traces to minimize PCB inductance.

For Boost converter, the current loop of the output capacitor from VOUT pin back to the PGND pin of the device should be as small as possible.

Layout Example

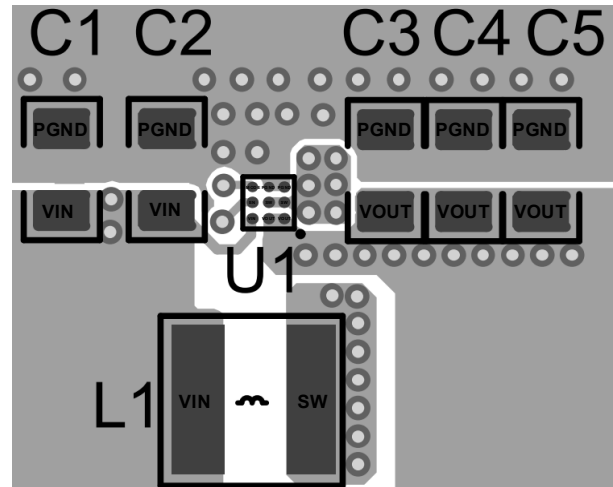

Figure 6. SGM66155 PCB Layout

REVISION HISTORY

NOTE: Page numbers for previous revisions may differ from page numbers in the current version.

Changes from Original to REV.A (DECEMBER 2025)	Page
Added SGM66155C	All
Changed from product preview to production data.....	All

PACKAGE INFORMATION

PACKAGE OUTLINE DIMENSIONS

WLCSP-1.20x1.21-9B

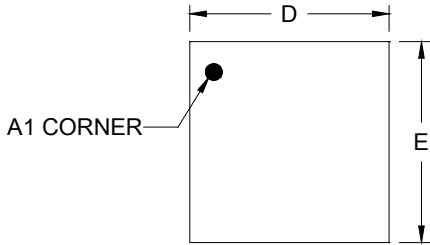

TOP VIEW

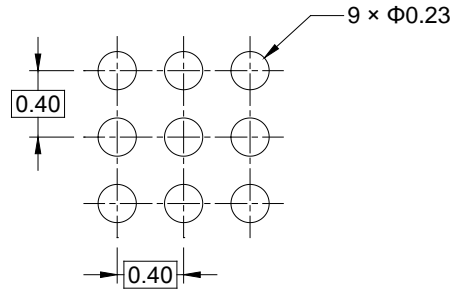

RECOMMENDED LAND PATTERN (Unit: mm)

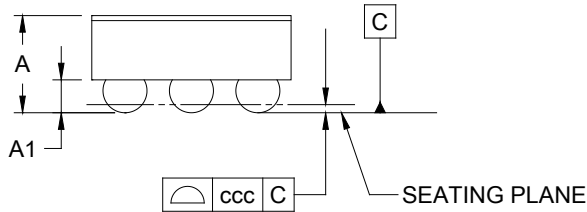

SIDE VIEW

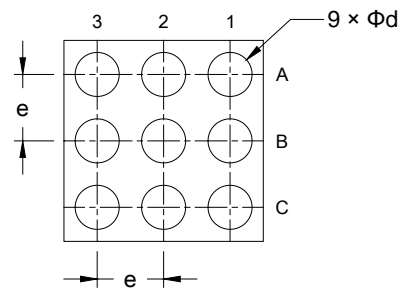

BOTTOM VIEW

Symbol	Dimensions In Millimeters		
	MIN	NOM	MAX
A	-	-	0.625
A1	0.178	-	0.218
D	1.171	-	1.231
E	1.180	-	1.240
d	0.235	-	0.295
e	0.400 BSC		
ccc	0.050		

NOTE: This drawing is subject to change without notice.

PACKAGE INFORMATION

TAPE AND REEL INFORMATION

REEL DIMENSIONS

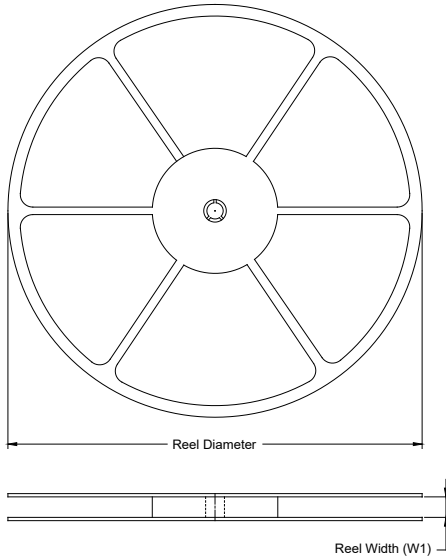

TAPE DIMENSIONS

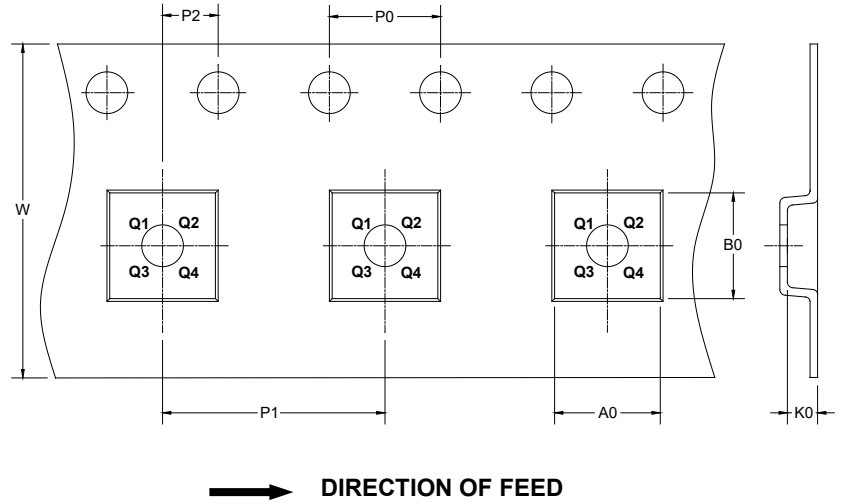

NOTE: The picture is only for reference. Please make the object as the standard.

KEY PARAMETER LIST OF TAPE AND REEL

Package Type	Reel Diameter	Reel Width W1 (mm)	A0 (mm)	B0 (mm)	K0 (mm)	P0 (mm)	P1 (mm)	P2 (mm)	W (mm)	Pin1 Quadrant
WLCSP-1.20×1.21-9B	7"	9.5	1.35	1.35	0.76	4.0	4.0	2.0	8.0	Q1

DD0001

PACKAGE INFORMATION

CARTON BOX DIMENSIONS

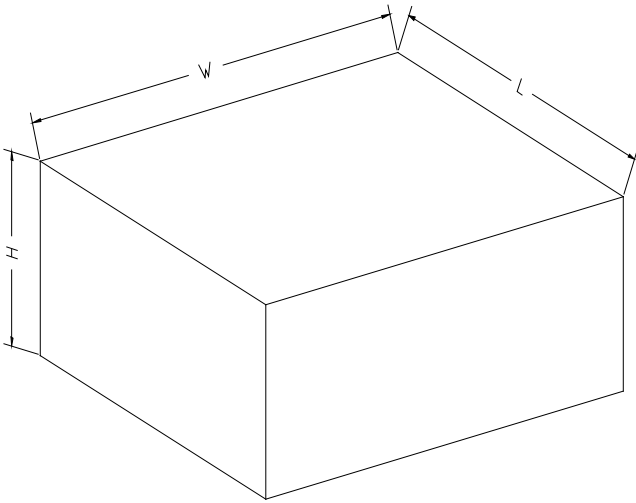

NOTE: The picture is only for reference. Please make the object as the standard.

KEY PARAMETER LIST OF CARTON BOX

Reel Type	Length (mm)	Width (mm)	Height (mm)	Pizza/Carton
7" (Option)	368	227	224	8
7"	442	410	224	18

D00002