

GENERAL DESCRIPTION

The SGM4594 is a general-purpose parallel input and output (I/O) expander device, which consists of two lanes and 8 bits parallel I/O expansion. The device communicates with processor through two-line bidirectional I²C bus (or SMBus), supporting I²C standard mode (100kHz) and I²C fast mode (400kHz) clock frequency. The SGM4594 provides a simple solution for the devices that need additional I/Os, such as LEDs, buttons, sensors, etc.

The SGM4594 can select device address by the A0, A1 and A2 pins. The SGM4594 features an interrupt generated on the nINT pin whenever the state of input port changes. An output anomaly may also be indicated by the nINT pin when the corresponding Output Anomaly Indication port register is set to 1 and the device is in push-pull output mode. The SGM4594 can cycle the power supply and cause a power-on reset to reset itself to the default state.

The SGM4594 is available in Green TSSOP-24 and TQFN-4x4-24FL packages and supports -40 °C to +125°C temperature range.

FEATURES

- 1.65V to 5.5V Input Voltage Range
- Parallel I²C I/O Expander
- 5V Tolerant Input and Output Ports
- Each Port has a 100kΩ Pull-up Resistor to V_{CC}
- Active Low Interrupt Output
- Support 400kHz I²C Fast Mode
- Internal Power-on Reset
- No Glitch on Power-up
- Polarity Inversion Register
- Compatible with Most Processors
- Select Device Address by Three Pins (up to Eight Devices)
- Latched Outputs Drive LEDs Directly
- Latch-up Performance (> 100mA) to Meet JESD 78, Class II Standard
- -40°C to +125°C Operating Temperature Range
- Available in Green TSSOP-24 and TQFN-4x4-24FL Packages

APPLICATIONS

I²C GPIO Expansion
 Industrial, Factory, Building, Test and Measurement

TYPICAL APPLICATION

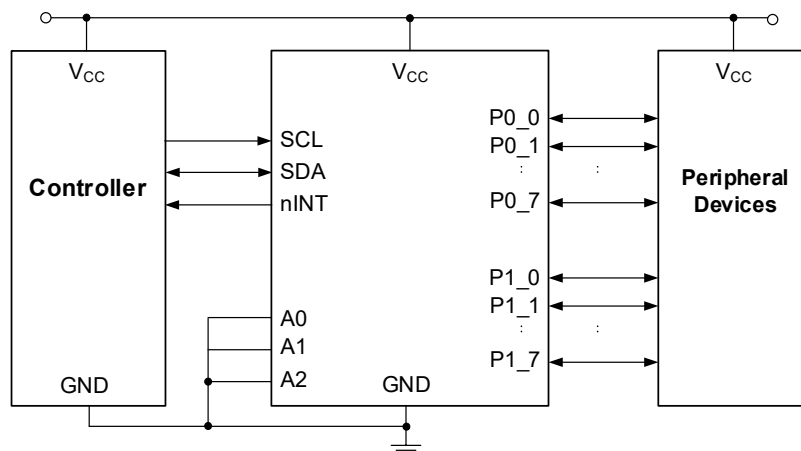

Figure 1. Typical Application Circuit

PACKAGE/ORDERING INFORMATION

MODEL	PACKAGE DESCRIPTION	SPECIFIED TEMPERATURE RANGE	ORDERING NUMBER	PACKAGE MARKING	PACKING OPTION
SGM4594	TSSOP-24	-40°C to +125°C	SGM4594XTS24G/TR	SGM4594 XTS24 XXXXX	Tape and Reel, 4000
	TQFN-4x4-24FL	-40°C to +125°C	SGM4594XTXD24G/TR	SGM4594 XTXD24 XXXXX	Tape and Reel, 3000

MARKING INFORMATION

NOTE: XXXXX = Date Code, Trace Code and Vendor Code.

XXXXX

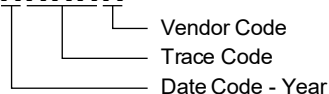

Green (RoHS & HSF): SG Micro Corp defines "Green" to mean Pb-Free (RoHS compatible) and free of halogen substances. If you have additional comments or questions, please contact your SGMICRO representative directly.

ABSOLUTE MAXIMUM RATINGS

Supply Voltage Range, V _{CC}	-0.5V to 6V
Input Voltage Range ⁽¹⁾ , V _I	-0.5V to 6V
Output Voltage Range ⁽¹⁾ , V _O	-0.5V to 6V
Input Clamp Current, I _{IK} (V _I < 0V)	-20mA
Output Clamp Current, I _{OK} (V _O < 0V)	-20mA
Input-Output Clamp Current, I _{IOK} (V _O < 0V or V _O > V _{CC})	±20mA
Continuous Output Low Current, I _{OL} (V _O = 0V to V _{CC}) ..	50mA
Continuous Output High Current, I _{OH} (V _O = 0V to V _{CC}) ..	50mA
Continuous Current through GND	-250mA
Continuous Current through V _{CC}	160mA
Package Thermal Resistance	
TSSOP-24, θ _{JA}	84°C/W
TSSOP-24, θ _{JB}	52.8°C/W
TSSOP-24, θ _{JC}	33.2°C/W
TQFN-4x4-24FL, θ _{JA}	45.4°C/W
TQFN-4x4-24FL, θ _{JB}	23.2°C/W
TQFN-4x4-24FL, θ _{JC} (TOP)	35.6°C/W
TQFN-4x4-24FL, θ _{JC} (BOT)	12.1°C/W
Junction Temperature	+150°C
Storage Temperature Range	-65°C to +150°C
Lead Temperature (Soldering, 10s)	+260°C
ESD Susceptibility ^{(2) (3)}	
HBM	±4000V
CDM	±1000V

NOTES:

1. When the input and output current ratings are observed, the input and I/O negative voltage ratings may be exceeded.

- For human body model (HBM), all pins comply with ANSI/ESDA/JEDEC JS-001 specifications.
- For charged device model (CDM), all pins comply with ANSI/ESDA/JEDEC JS-002 specifications.

RECOMMENDED OPERATING CONDITIONS

Supply Voltage Range, V _{CC}	1.65V to 5.5V
I/O Ports Voltage Range, V _{I/O}	
SCL, SDA, A0, A1, A2, nINT	-0.5V to 5.5V
For P0_7-0, P1_7-0 Configured as Outputs	-0.5V to 5.5V
For P0_7-0, P1_7-0 Configured as Inputs	-0.5V to 5.5V
High-Level Input Voltage Range, V _{IH}	
SCL, SDA, A0, A1, A2, P0_7-0, P1_7-0	0.65 × V _{CC} (MIN)
Low-Level Input Voltage, V _{IL}	
SCL, SDA, A0, A1, A2, P0_7-0, P1_7-0	0.35 × V _{CC} (MAX)
High-Level Output Current, I _{OH} (P0_7-0, P1_7-0)	
.....	-10mA (MAX)
Low-Level Output Current, I _{OL} (P0_7-0, P1_7-0)	
T _J ≤ +65°C	25mA (MAX)
T _J = +85°C	18mA (MAX)
T _J = +105°C	9mA (MAX)
T _J = +125°C	4.5mA (MAX)
T _J = +135°C	3.5mA (MAX)
Low-Level Output Current, I _{OL} (nINT, SDA)	
T _J ≤ +85°C	6mA (MAX)
T _J = +105°C	3mA (MAX)
T _J = +125°C	1.8mA (MAX)
T _J = +135°C	1.5mA (MAX)
Operating Ambient Temperature Range	-40°C to +125°C

ESD SENSITIVITY CAUTION

This integrated circuit can be damaged if ESD protections are not considered carefully. SGMICRO recommends that all integrated circuits be handled with appropriate precautions. Failure to observe proper handling and installation procedures can cause damage. ESD damage can range from subtle performance degradation to complete device failure. Precision integrated circuits may be more susceptible to damage because even small parametric changes could cause the device not to meet the published specifications.

OVERSTRESS CAUTION

Stresses beyond those listed in Absolute Maximum Ratings may cause permanent damage to the device. Exposure to absolute maximum rating conditions for extended periods may affect reliability. Functional operation of the device at any conditions beyond those indicated in the Recommended Operating Conditions section is not implied.

DISCLAIMER

SG Micro Corp reserves the right to make any change in circuit design, or specifications without prior notice.

PIN CONFIGURATIONS

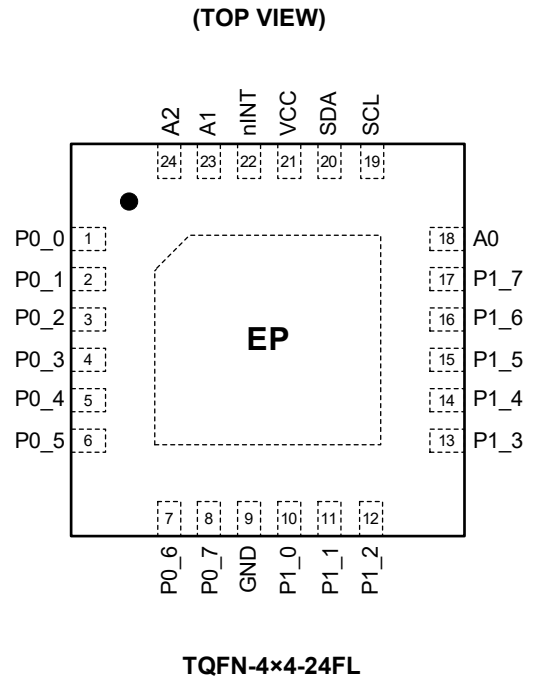
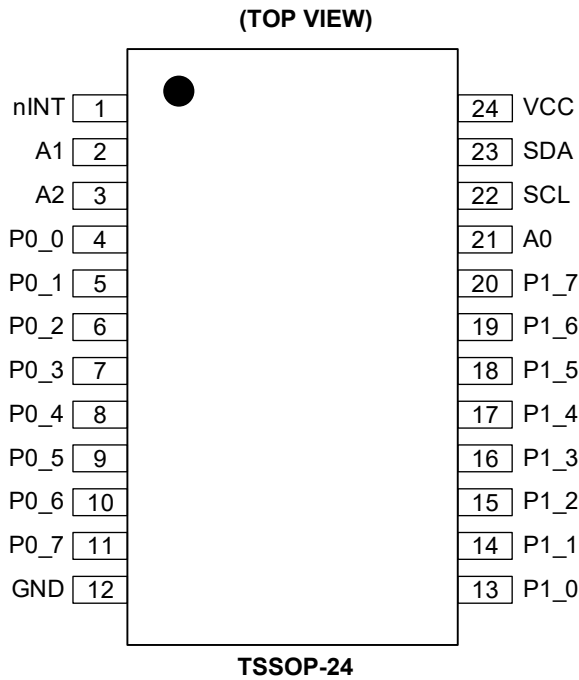

PIN DESCRIPTION

PIN		NAME	TYPE	DESCRIPTION
TSSOP-24	TQFN-4x4-24FL			
1	22	nINT	O	Open-Drain Output Pin. A pull-up resistor is used to connect to V _{CC} .
2	23	A1	I	Analog Input A1. Connected to V _{CC} or GND.
3	24	A2	I	Analog Input A2. Connected to V _{CC} or GND.
4-11	1-8	P0_0-7	I/O	P0_0 to P0_7 of Port 0 Input/Output. Default as an input at power-on.
12	9	GND	G	Ground.
13-20	10-17	P1_0-7	I/O	P1_0 to P1_7 of Port 1 Input/Output. Default as an input at power-on.
21	18	A0	I	Analog Input A0. Connected to V _{CC} or GND.
22	19	SCL	I	Clock Signal.
23	20	SDA	I/O	Data Signal.
24	21	VCC	P	Supply Voltage.
—	Exposed Pad	EP	—	Thermal Pad. It can be connected to GND or be left floating. This pad is not an electrical connection point.

NOTE: I = input, O = output, I/O = input/output, P = power, G = ground.

ELECTRICAL CHARACTERISTICS(Full = -40°C to +125°C, all typical values are measured at T_A = +25°C and V_{CC} = 1.8V, 2.5V, 3.3V or 5V, unless otherwise noted.)

PARAMETER	SYMBOL	CONDITIONS		MIN	TYP	MAX	UNITS	
Input Diode Clamp Voltage	V _{IK}	I _I = -18mA, V _{CC} = 1.65V to 5.5V		-1.2			V	
Power-On Reset Voltage, V _{CC} Rising	V _{PORR}	V _I = V _{CC} or GND, V _{CC} = 1.65V to 5.5V			1.2	1.5	V	
Power-On Reset Voltage, V _{CC} Falling	V _{PORF}	V _I = V _{CC} or GND, V _{CC} = 1.65V to 5.5V		0.6	1.0		V	
P-Port High-Level Output Voltage ⁽¹⁾	V _{OH}	I _{OH} = -8mA	V _{CC} = 1.65V	1.25			V	
			V _{CC} = 2.3V	1.90				
			V _{CC} = 3V	2.65				
			V _{CC} = 3.6V	3.30				
			V _{CC} = 4.75V	4.45				
		I _{OH} = -10mA	V _{CC} = 1.65V	1.10				
			V _{CC} = 2.3V	1.80				
			V _{CC} = 3V	2.60				
			V _{CC} = 3.6V	3.20				
			V _{CC} = 4.75V	4.35				
Low-Level Output Current	I _{OL}	SDA	V _{CC} = 1.65V to 5.5V, V _{OL} = 0.4V	3			mA	
		P-Port ⁽²⁾	V _{CC} = 1.65V to 5.5V, V _{OL} = 0.5V	8				
			V _{CC} = 1.65V to 5.5V, V _{OL} = 0.7V	10				
		nINT	V _{CC} = 1.65V to 5.5V, V _{OL} = 0.4V	3				
Input Leakage Current	I _I	SCL, SDA	V _I = V _{CC} or GND, V _{CC} = 1.65V to 5.5V			±1	μA	
		A0, A1, A2				±1		
High-Level Input Current	I _{IH}	P-Port	V _I = V _{CC} , V _{CC} = 1.65V to 5.5V			1	μA	
Low-Level Input Current	I _{IL}	P-Port	V _I = GND, V _{CC} = 1.65V to 5.5V			-100		
Quiescent Supply Current	I _{CC}	Operating Mode	V _I = V _{CC} , I _O = 0A, I/O = inputs, f _{SCL} = 400kHz, no load	V _{CC} = 5.5V		24	40	μA
				V _{CC} = 3.6V		13	30	
				V _{CC} = 2.7V		9	19	
				V _{CC} = 1.95V		6	11	
			V _I = GND, I _O = 0A, I/O = inputs, f _{SCL} = 400kHz, no load	V _{CC} = 5.5V		885	1500	
				V _{CC} = 3.6V		580	1300	
				V _{CC} = 2.7V		430	1000	
				V _{CC} = 1.95V		320	900	
		Standby Mode	V _I = V _{CC} , I _O = 0A, I/O = inputs, f _{SCL} = 0kHz, no load	V _{CC} = 5.5V		0.50	3.9	
				V _{CC} = 3.6V		0.45	2.2	
				V _{CC} = 2.7V		0.4	1.8	
				V _{CC} = 1.95V		0.35	1.5	
V _I = GND, I _O = 0A, I/O = inputs, f _{SCL} = 0kHz, no load	V _{CC} = 5.5V		865	1500				
	V _{CC} = 3.6V		565	1300				
	V _{CC} = 2.7V		425	1000				
	V _{CC} = 1.95V		310	900				
Input Capacitance	C _I	SCL	V _I = V _{CC} or GND	V _{CC} = 1.65V to 5.5V		7	pF	
Input/Output Capacitance	C _{IO}	SDA	V _{I/O} = V _{CC} or GND	V _{CC} = 1.65V to 5.5V		8	pF	
		P-Port				11		

NOTES:

- Each octal (P0_7-0 and P1_7-0) has a limitation to the maximum allowed I_{OL} (100mA) externally and a total of 200mA for a device.
- The maximum total sourced current by all I/Os must be less than 160mA.

I²C INTERFACE TIMING REQUIREMENTS

(Full = -40°C to +125°C, unless otherwise noted.)

PARAMETER	SYMBOL	CONDITIONS	MIN ⁽¹⁾	TYP	MAX ⁽¹⁾	UNITS
I²C Bus-Standard Mode						
I ² C Clock Frequency	f _{SCL}		0		100	kHz
I ² C Clock High Time	t _{SCH}		4			μs
I ² C Clock Low Time	t _{SCL}		4.7			μs
I ² C Spike Time	t _{SP}				50	ns
I ² C Serial-Data Setup Time	t _{SU_DAT}		250			ns
I ² C Serial-Data Hold Time	t _{HD_DAT}		0			ns
I ² C Input Rise Time	t _{IR}				1000	ns
I ² C Input Fall Time	t _{IF}				300	ns
I ² C Output Fall Time	t _{OF}	10pF to 400pF bus			300	ns
I ² C Bus Free Time between Stop and Start	t _{BUF}		4.7			μs
I ² C Setup Time for Start or Repeated Start Condition	t _{STS}		4.7			μs
I ² C Hold Time for Start or Repeated Start Condition	t _{STH}		4			μs
I ² C Setup Time for Stop Condition	t _{SPS}		4			μs
Valid Data Time	t _{VD_DAT}	SCL low to SDA output valid			3.45	μs
Valid Data Time of ACK Condition	t _{VD_ACK}	ACK signal from SCL low to SDA (out) low			3.45	μs
I ² C Bus Capacitive Load	C _B				400	pF
I²C Bus-Fast Mode						
I ² C Clock Frequency	f _{SCL}		0		400	kHz
I ² C Clock High Time	t _{SCH}		0.6			μs
I ² C Clock Low Time	t _{SCL}		1.3			μs
I ² C Spike Time	t _{SP}				50	ns
I ² C Serial-Data Setup Time	t _{SU_DAT}		100			ns
I ² C Serial-Data Hold Time	t _{HD_DAT}		0			ns
I ² C Input Rise Time	t _{IR}		20		300	ns
I ² C Input Fall Time	t _{IF}		20 × (V _{CC} /5.5V)		300	ns
I ² C Output Fall Time	t _{OF}	10pF to 400pF bus	20 × (V _{CC} /5.5V)		300	ns
I ² C Bus Free Time between Stop and Start	t _{BUF}		1.3			μs
I ² C Setup Time for Start or Repeated Start Condition	t _{STS}		0.6			μs
I ² C Hold Time for Start or Repeated Start Condition	t _{STH}		0.6			μs
I ² C Setup Time for Stop Condition	t _{SPS}		0.6			μs
Valid Data Time	t _{VD_DAT}	SCL low to SDA output valid			0.9	μs
Valid Data Time of ACK Condition	t _{VD_ACK}	ACK signal from SCL low to SDA (out) low			0.9	μs
I ² C Bus Capacitive Load	C _B				400	pF

NOTE: 1. Specified by design and characterization, not production tested.

SWITCHING CHARACTERISTICS(Full = -40°C to +125°C, C_L ≤ 100pF, unless otherwise noted.)

PARAMETER	SYMBOL	CONDITIONS	MIN	TYP	MAX	UNITS
Interrupt Valid Time	t _{IV}	From P-Port to nINT			4	μs
Interrupt Reset Delay Time	t _{IR}	From SCL to nINT			4	μs
Data Output Valid Time ⁽¹⁾	t _{VD}	From SCL to P-Port	V _{CC} = 2.3V to 5.5V		200	ns
			V _{CC} = 1.65V to 2.3V		300	ns
Data Input Setup Time ⁽¹⁾	t _{DSU}	From P-Port to SCL	1			CLK
Data Input Hold Time ⁽¹⁾	t _{DH}	From P-Port to SCL	1			μs

NOTE: 1. Specified by design and characterization, not production tested.

TEST CIRCUIT

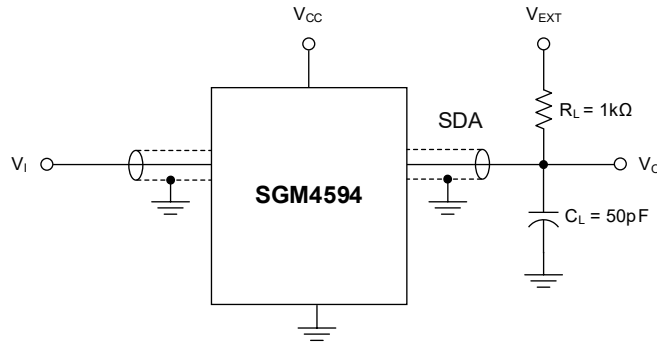
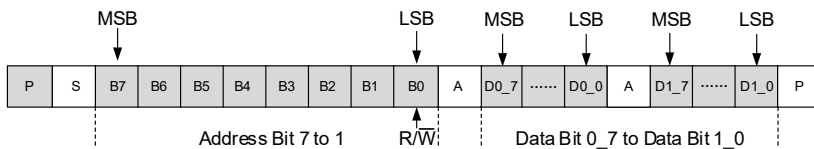

Figure 2. I²C Interface Load Circuit

NOTES:

1. R_L refers to load resistance. C_L refers to load capacitance (includes jig and probe).
2. All inputs are supplied by generators featured by: $PRR \leq 10\text{MHz}$, $Z_O = 50\Omega$, $t_R/t_F \leq 30\text{ns}$.

WAVEFORMS



Byte	Description
1	I ² C Address
2, 3	P-Port Data

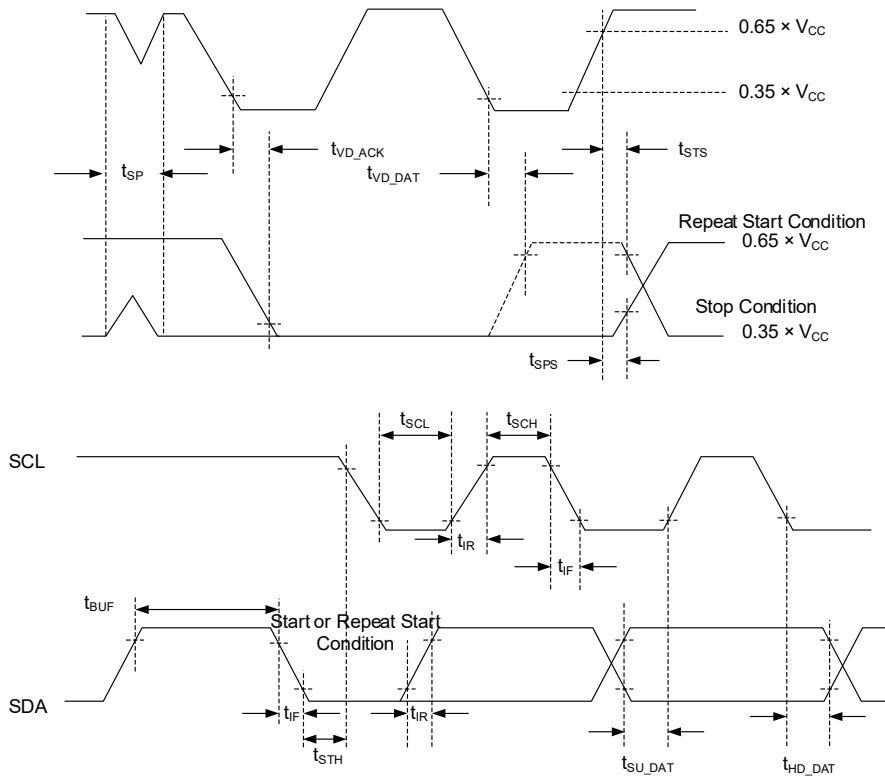

Figure 3. I²C Interface Voltage Waveforms

TEST CIRCUIT (continued)

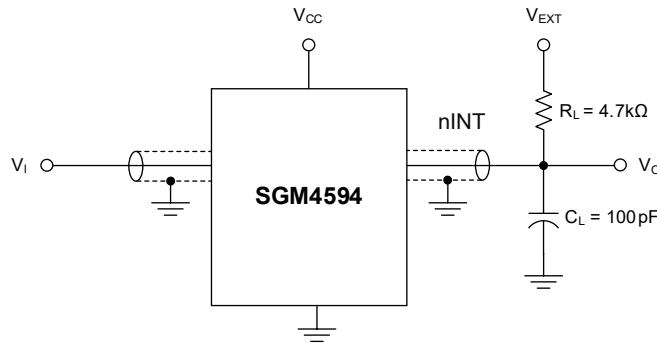

Figure 4. Interrupt Load Circuit

NOTES:

1. R_L refers to load resistance. C_L refers to load capacitance (includes jig and probe).
2. All inputs are supplied by generators featured by: $PRR \leq 10\text{MHz}$, $Z_O = 50\Omega$, $t_{r/f} \leq 30\text{ns}$.

WAVEFORMS

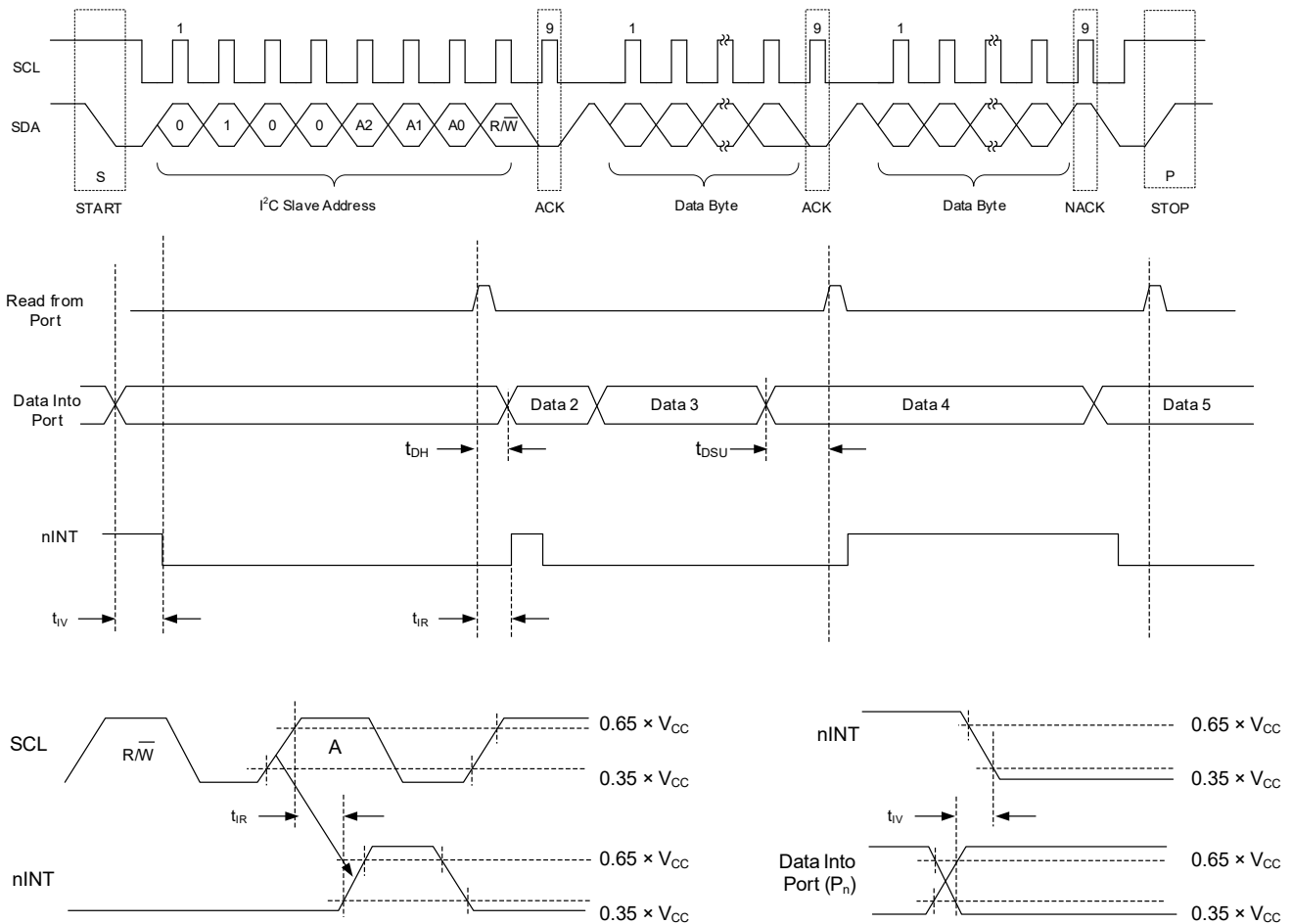

Figure 5. Interrupt Voltage Waveforms

TEST CIRCUIT (continued)

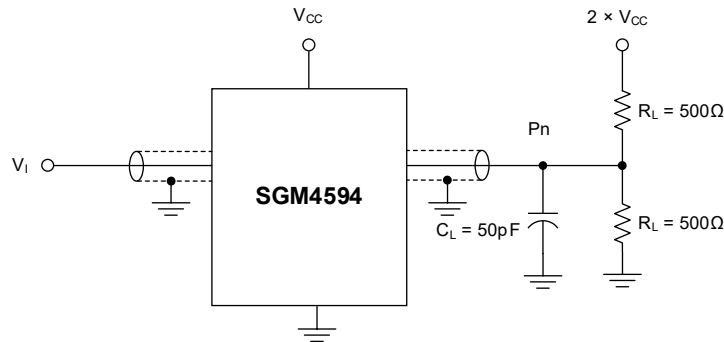

Figure 6. P-Port Load Circuit

NOTES:

1. R_L refers to load resistance. C_L refers to load capacitance (includes jig and probe).
2. All inputs are supplied by generators featured by: $PRR \leq 10\text{MHz}$, $Z_O = 50\Omega$, $t_R/t_F \leq 30\text{ns}$.
3. t_{VD} is measured from $0.65 \times V_{CC}$ on SCL to 50% I/O (P_n) output.
4. The outputs are measured one by one with a transition every measurement.

WAVEFORMS

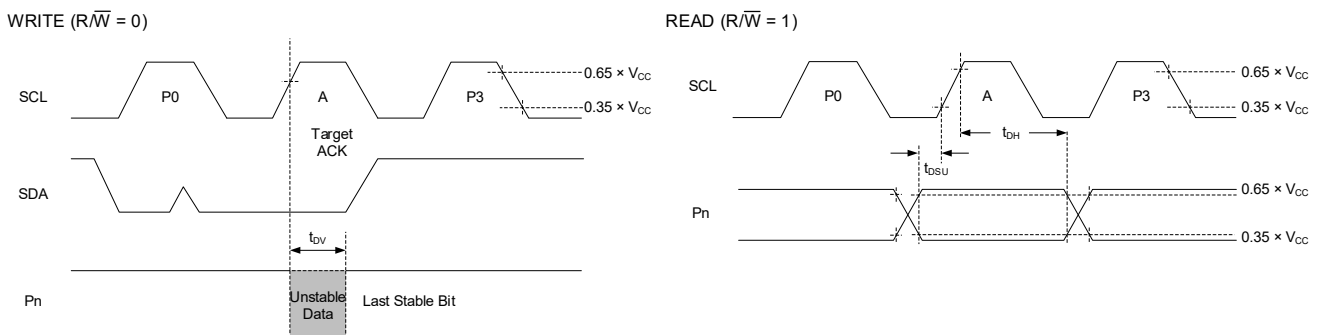
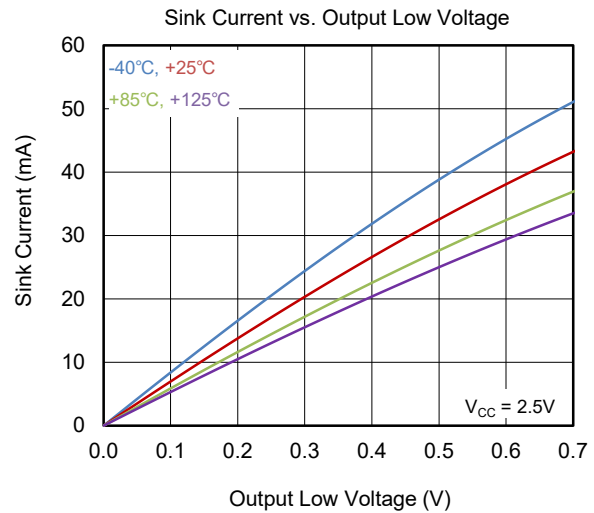
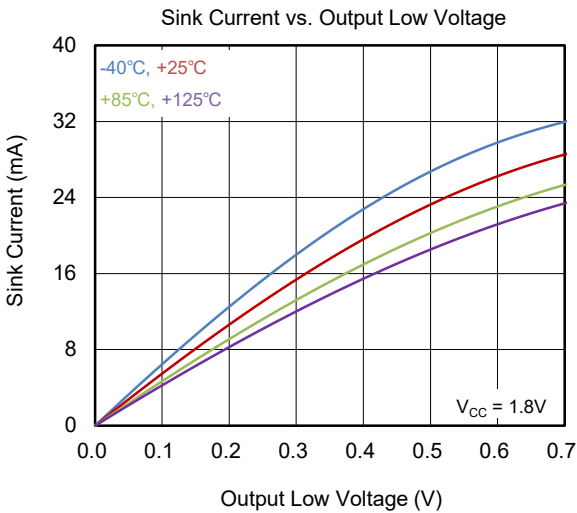
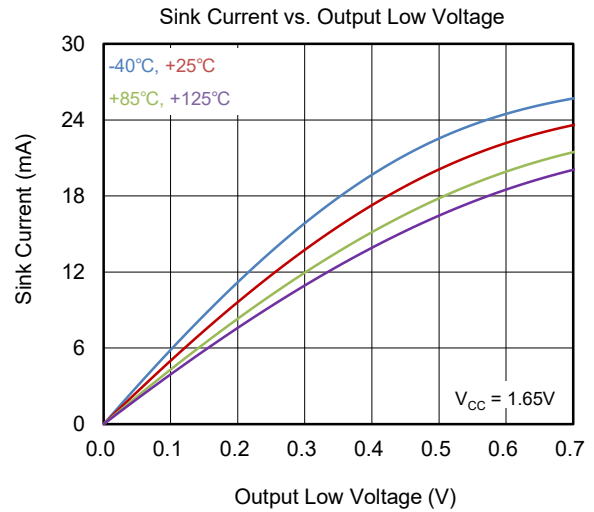
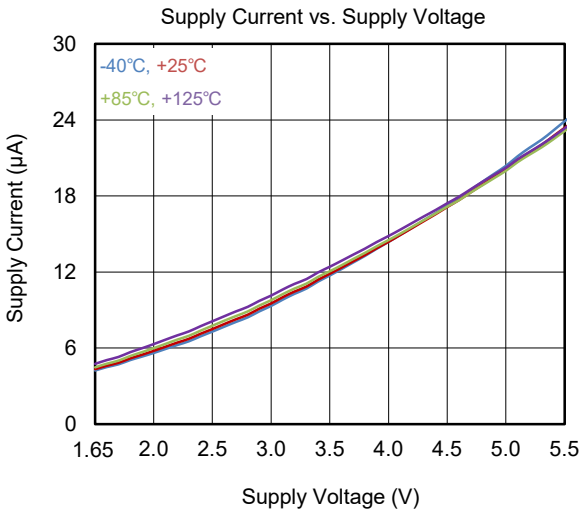
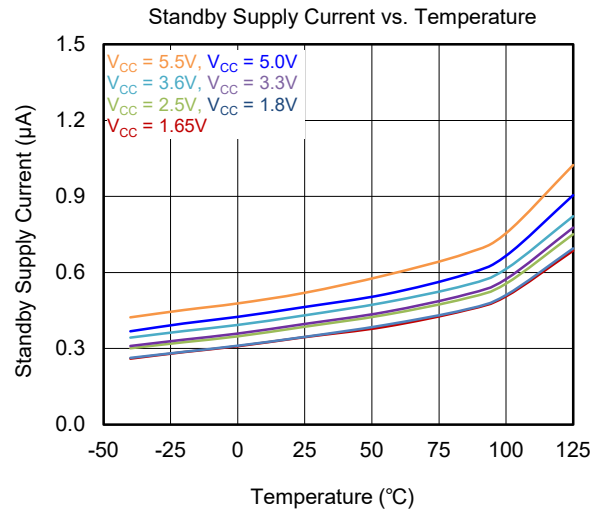
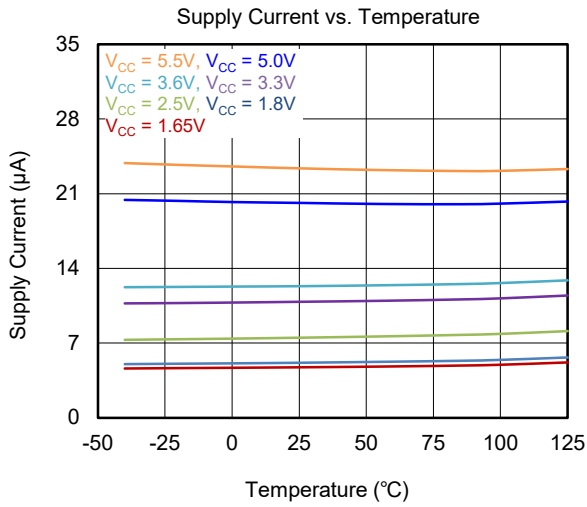

Figure 7. P-Port Voltage Waveforms

TYPICAL PERFORMANCE CHARACTERISTICS

T_A = +25°C, unless otherwise noted.



TYPICAL PERFORMANCE CHARACTERISTICS (continued)

T_A = +25°C, unless otherwise noted.

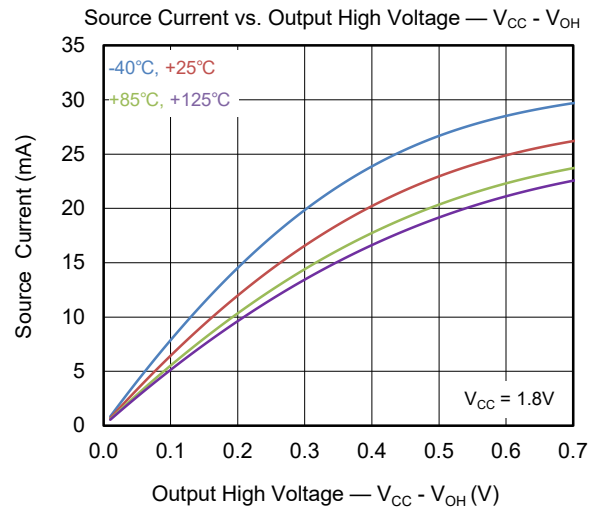
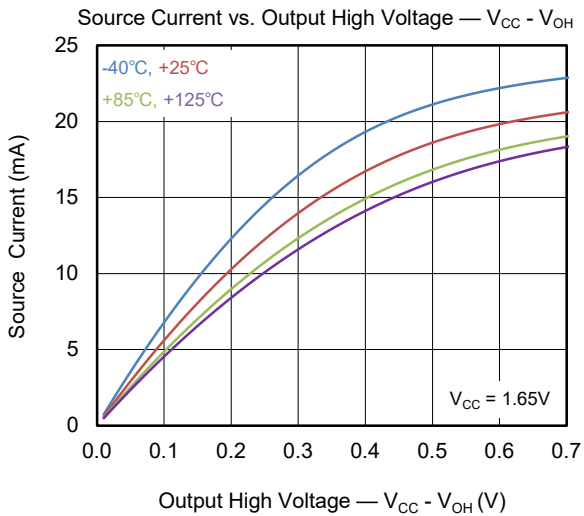
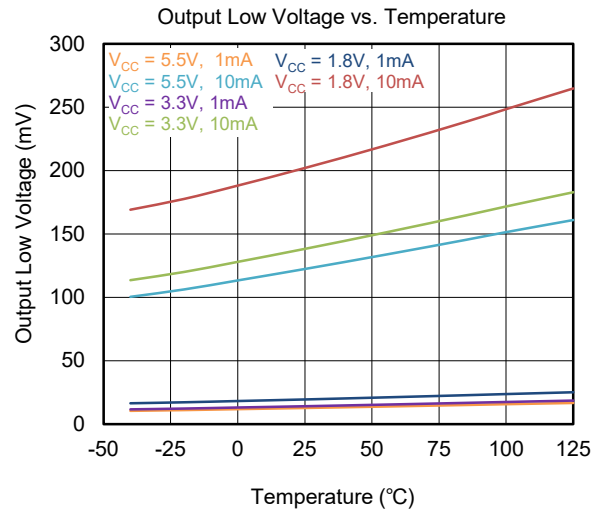
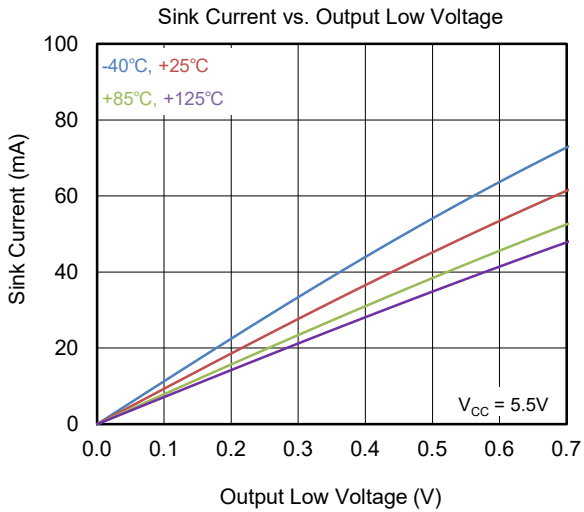
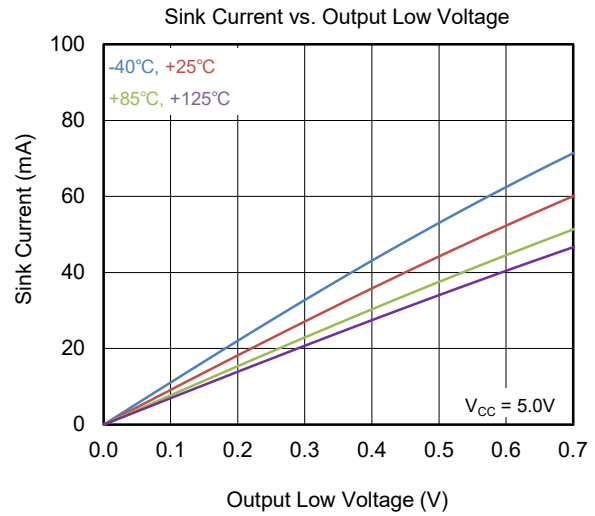
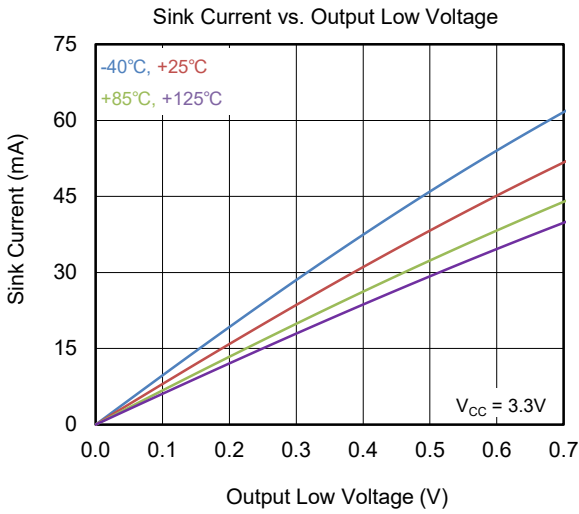

TYPICAL PERFORMANCE CHARACTERISTICS (continued)

T_A = +25°C, unless otherwise noted.

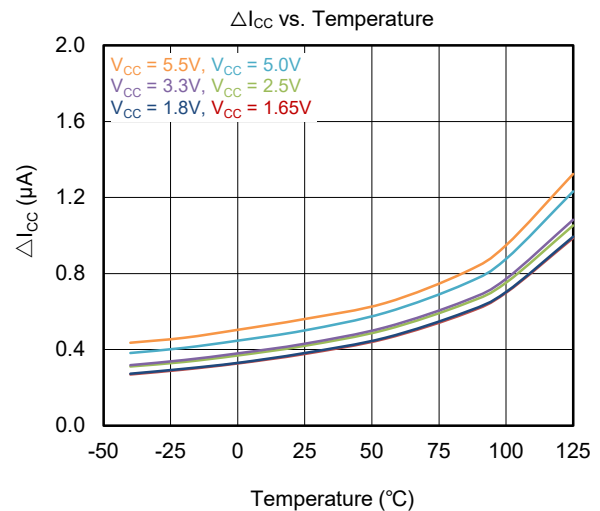
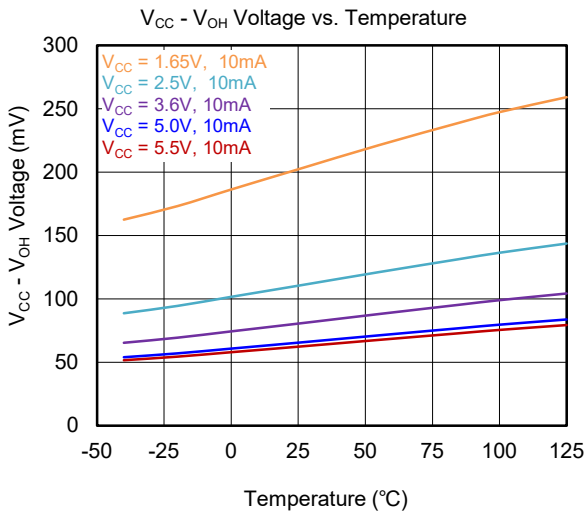
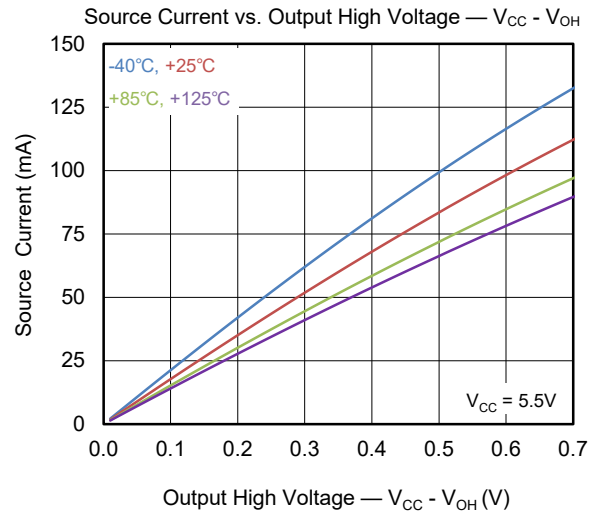
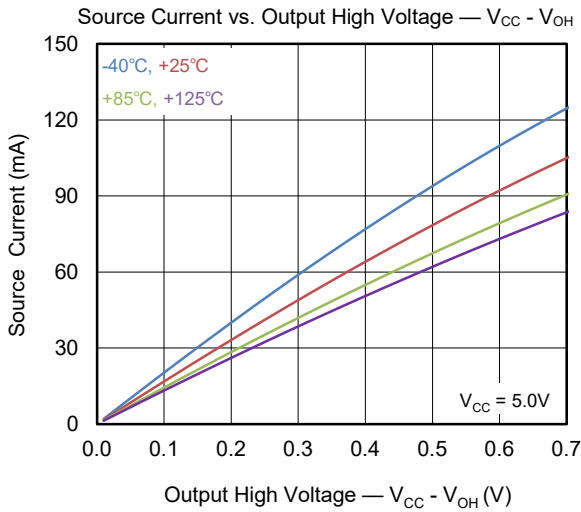
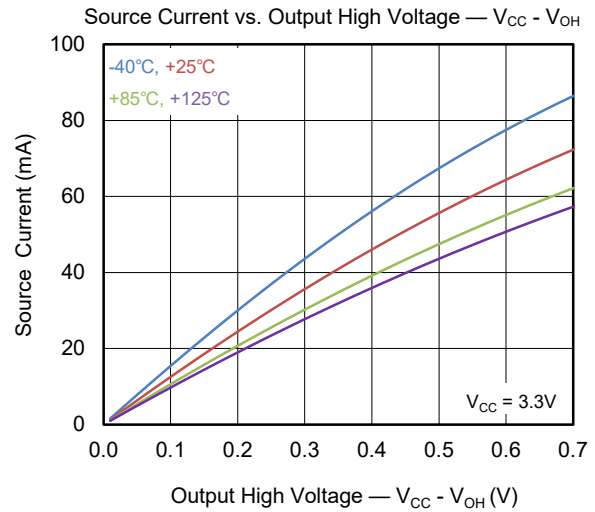
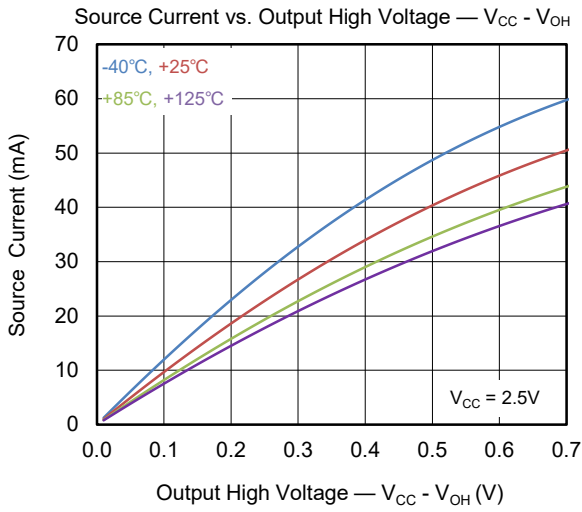

FUNCTIONAL BLOCK DIAGRAM

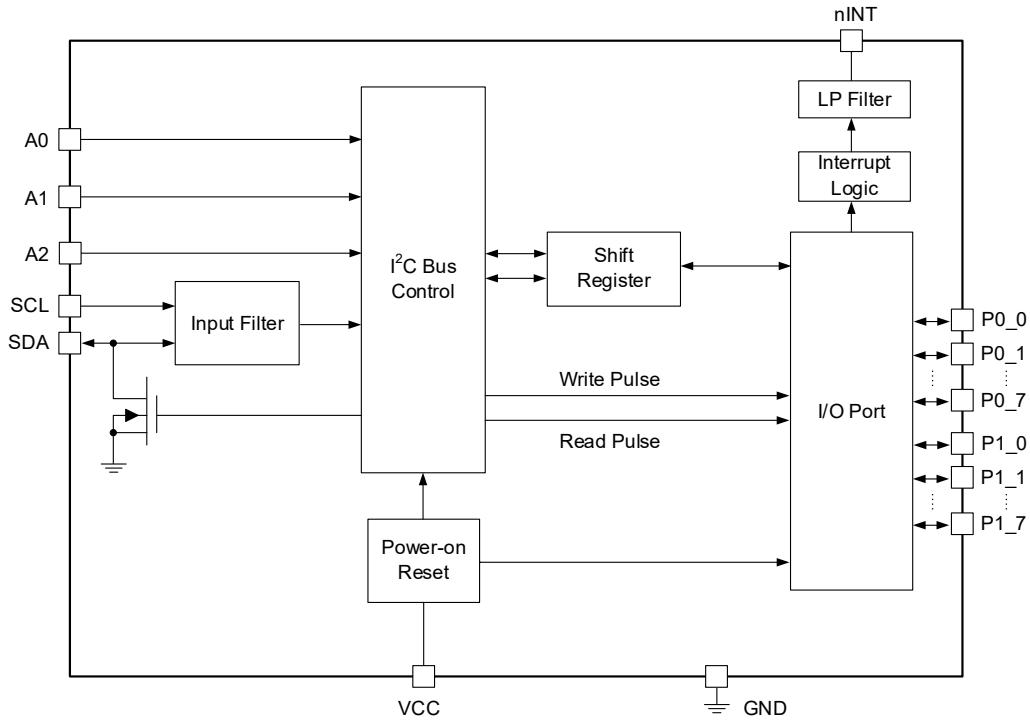

NOTE: All I/Os are set as inputs when reset.

Figure 8. Block Diagram (Positive Logic)

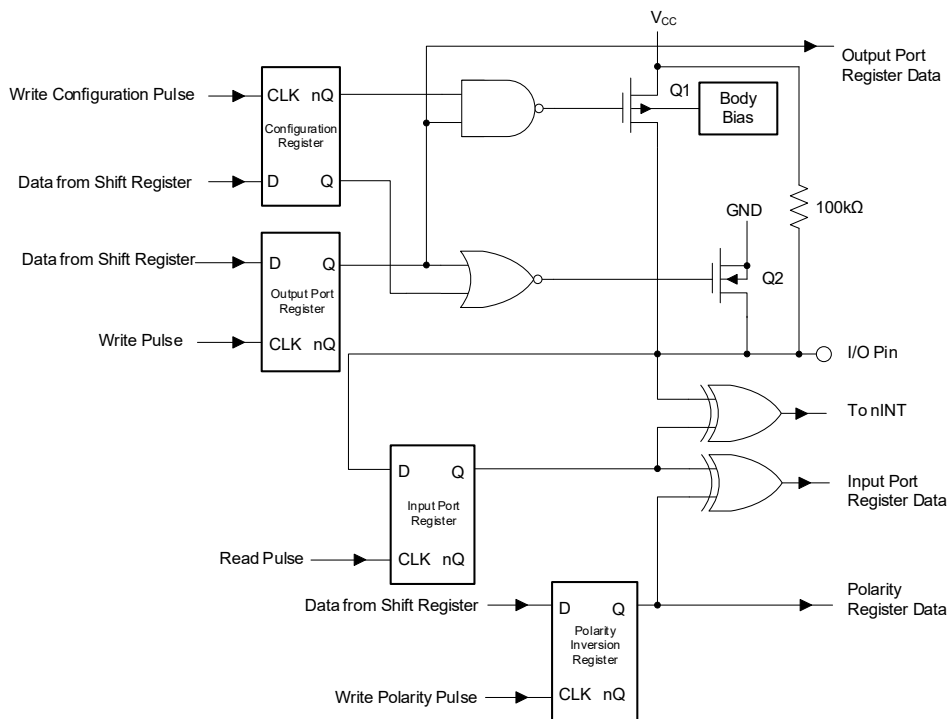

NOTE: At power-on reset, all registers return to default values.

Figure 9. Simplified Schematic of P-Port Inputs or Outputs

DETAILED DESCRIPTION

Overview

The SGM4594 is a multi-use parallel I/O expander device, which consists of two lanes, 8 bits parallel I/O expansion. It communicates with processor through two-line bidirectional I²C bus (or SMBus).

The SGM4594 has two groups of 8-bit registers, including Input Port x ($x = 0, 1$), Output Port x , Polarity Inversion x , Configuration Port x , Output Mode Configuration x , and Output Anomaly Port x . When the device is powered on, all ports are designed as inputs. Writing to the register Configuration Port x could set the corresponding ports as input or output. Writing '1' to the Polarity Inversion x register can invert the polarity of the input register. The register Output Mode Configuration x can configure ports as push-pull or open-drain when the corresponding ports are set as output mode. And the Output Anomaly Port x can be enabled to indicate the situation of output short-circuit. All registers can be read by the processor.

Any input state differing from its corresponding Input Port x register can cause the open-drain interrupt (nINT) activation. If the Output Anomaly Port x is enabled, in the situation that the output state differs from its corresponding Output Port register, the nINT output is also activated. It is used to indicate an output anomaly to the processor.

The SGM4594 can remain a simple target device. The nINT can be connected to the input of a processor, the remote I/O can inform the processor whether there is incoming data changing or an output anomaly without I²C bus.

The SGM4594 may select device address by the A0, A1 and A2 pins and allow up to eight devices to share the same I²C or SMBus.

Feature Description

I/O Ports

The I/Os would be in high-impedance state with a weak pull-up to V_{CC} when configured as an input because FETs Q1 and Q2 are off. The input voltage may be raised above V_{CC} to a maximum of 5.5V.

When the I/Os are designed as an output, the state of Output Port x decides whether Q1 or Q2 to be enabled. In this case, the low-impedance paths exist between the ports pin and either V_{CC} or GND. For proper operation, the external voltage applied to this port pin must not exceed the recommended voltage. The output mode can be set as push-pull or open-drain via the Output Mode Configuration x register.

Interrupt (nINT) Output

Any change of the state of port pins can generate an interrupt in the input mode. It also can be generated when output anomaly occurs and the nINT indicator function is enabled in the push-pull output mode. The actual pin value can be read from the Input Port registers. Therefore, the abnormal output bits can be identified.

The nINT signal becomes valid after the interrupt valid time (t_{IV}). The nINT would be reset when the state of port pins changes to the original setting or the corresponding Input Port x register is read. In the read mode, the resetting occurs at the acknowledge (ACK) bit after the rising edge of SCL signal. Pay attention to that the nINT is reset at the ACK before sending the changed data bytes. Interrupt that occurs during the ACK clock pulse may be lost (or be very short) due to resetting of interrupt during this pulse. After resetting, each change of the port pin in the input mode would be detected and transmitted as nINT.

There is no effect on the interrupt circuit when operating a read or a write to another device. If the state of a port pin is not consistent with the content of the corresponding Input Port x register, a false interrupt may occur when changing an I/O port from an output state to an input state. Due to that each 8-bit port is read independently, when port 0 causes an interrupt, it will not be cleared by reading port 1, or vice versa.

nINT needs a pull-up resistor to V_{CC} due to the open-drain structure.

DETAILED DESCRIPTION (continued)

Function Mode

Power-on Reset (POR)

During power-on, the POR function keeps the SGM4594 in a reset state until V_{CC} reaches V_{PORR}. Then, the SGM4594 would release the reset condition and initialize its register to the default state. After that, V_{CC} must be lowered to V_{PORF} and then backs to the operating voltage for a power-reset cycle.

Programming

I²C Interface

The SGM4594 has a standard bidirectional I²C interface that may be controlled by a processor that can configure or read the state of this device. The SGM4594 has a specific device address to distinguish it from other targets on the same I²C bus.

I²C is a well-known 2-wire serial communication interface that can connect one (or more) master device(s) to some slave devices for two-way communication. The bus lines are named serial data (SDA) and serial clock (SCL). The device that initiates a data transfer is a master. A master generates the SCL signal. Slave devices have unique addresses to identify. A master is typically a micro controller or a digital signal processor. Bus lines are pulled high by weak current source or pull-up resistors and in logic high state with no clocking when the bus is idle. The SDA and SCL pins are open-drain. Data transfer can only begin when the bus is idle. When both the SDA and SCL lines are high after the stop condition, the bus is considered idle.

Figure 10 and Figure 11 show the general processor for a processor accessing a target device:

1. Send data to target:
 - ◆ Controller-transmitter sends a START signal and device address to the target receiver.
 - ◆ Controller-transmitter sends data to target receiver.

2. Receive data from target:
 - ◆ Controller-receiver sends a START signal and device address to the target transmitter.
 - ◆ Controller-receiver sends the relevant register address to the target transmitter.
 - ◆ Controller-receiver receives data from the target transmitter.
 - ◆ Controller-receiver sends a STOP signal to terminate this transfer.

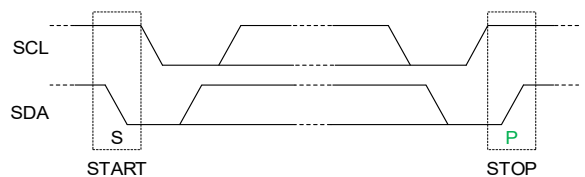

Figure 10. I²C Bus in START and STOP Conditions

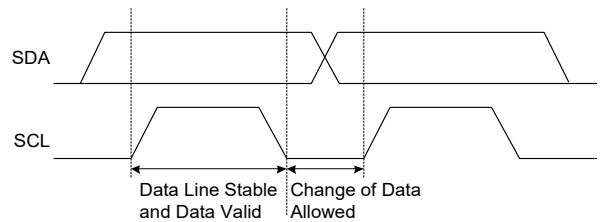

Figure 11. Bit Transfer

The interface definition is illustrated in Table 1.

Table 1. Interface Definition

Byte	Bits							
	D7 (MSB)	D6	D5	D4	D3	D2	D1	D0 (LSB)
I ² C Target Address	0	1	0	0	A2	A1	A0	R/W
P0_x I/O Data Bus	P0_7	P0_6	P0_5	P0_4	P0_3	P0_2	P0_1	P0_0
P1_x I/O Data Bus	P1_7	P1_6	P1_5	P1_4	P1_3	P1_2	P1_1	P1_0

DETAILED DESCRIPTION (continued)

Bus Transactions

The controller and the SGM4594 can finish data transactions through R/W commands.

Registers are located in the memory of target containing information, no matter what it is the configuration information or some sampled data sent to the controller. The controller instructs the SGM4594 to perform some tasks through writing information to these registers.

WRITE: The controller sends a START condition accompanied by the address of target, and the last bit

is written as '0', which indicates a 'write' command. After receiving the ACK signal, the controller sends the register address. The SGM4594 sends the ACK signal again, indicating it is ready. Then, the controller starts transmitting the register data to the target until the controller has sent all the necessary data. The controller could send a STOP condition to terminate the transmission.

See the **Control Register and Command Byte** section for more details. Figure 12 indicates the write of a single byte to a target register.

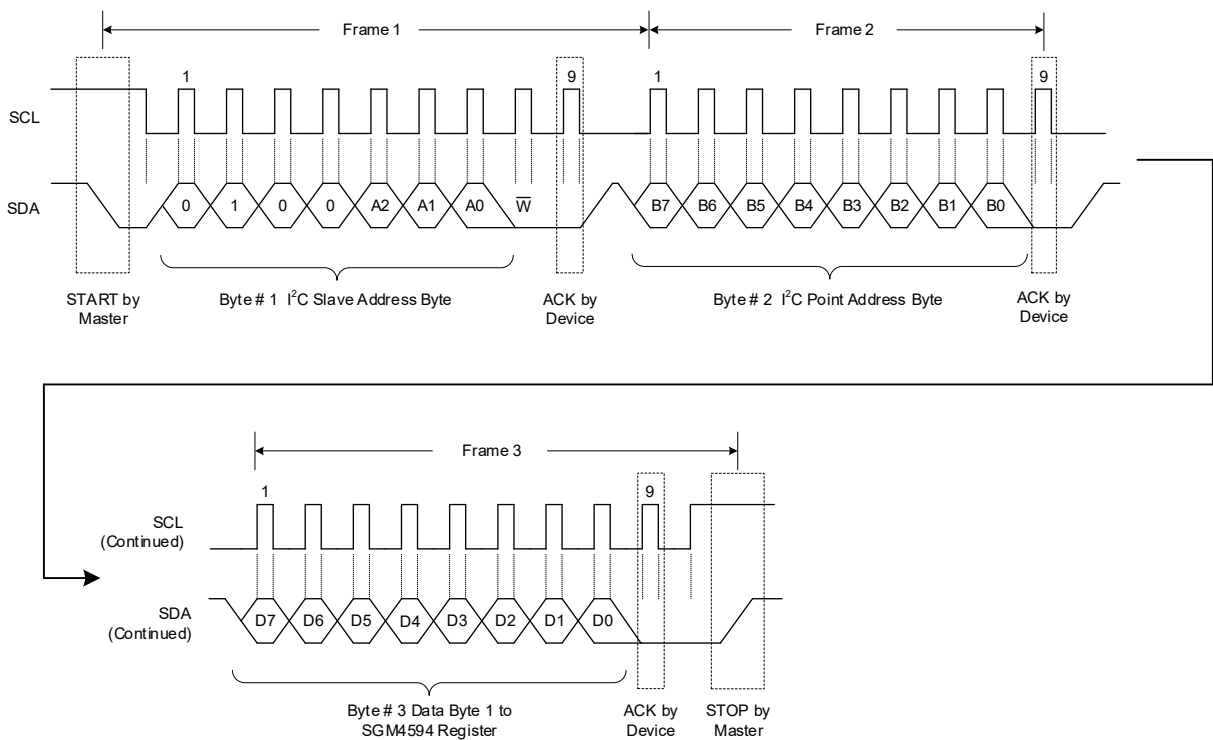

Figure 12. Write to Register

DETAILED DESCRIPTION (continued)

Figure 13 indicates the write to the Polarity Inversion register.

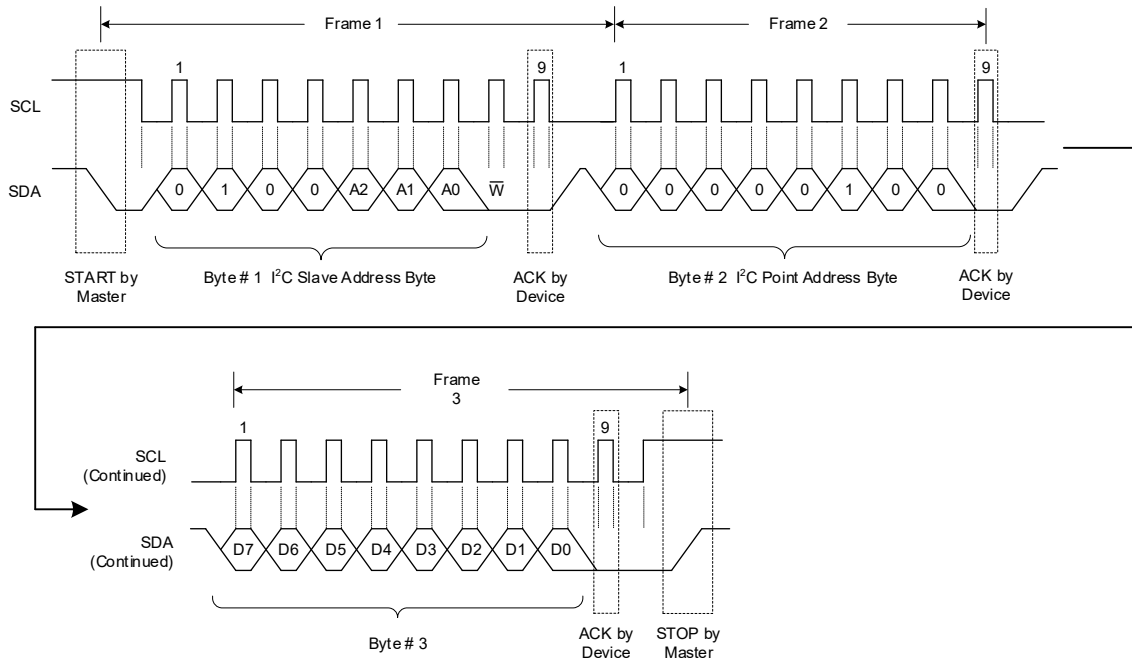

Figure 13. Write to the Polarity Inversion Port 0 Register

Figure 14 indicates the write to Output Port register.

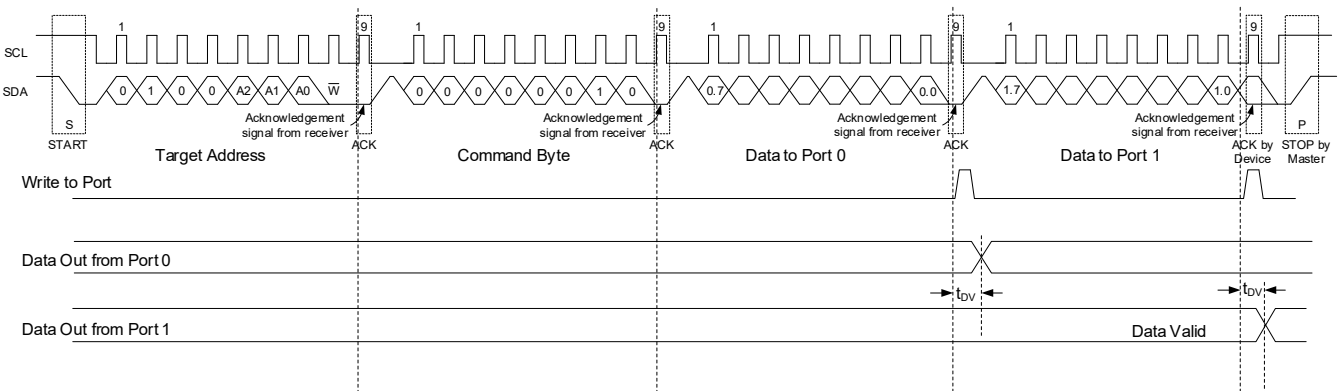

Figure 14. Write to Output Port 0 Register

DETAILED DESCRIPTION (continued)

READ: ‘Read’ command is similar to ‘write’ command, but needs a few extra steps. Reading from a target requests that the controller must firstly give the target an instruction about which register it wants to read from. This step is consistent with ‘write’, and the last bit is written ‘0’ (indicating a ‘write’), followed by the register it wants to read from. After receiving the ACK signal, the controller sends a START again with the last bit written ‘1’ (indicating a ‘read’). Then, the SGM4594 sends the ACK signal again, indicating it is ready. And the controller releases the SDA but still supplies the clock signal to the target. In this transaction, the controller becomes the receiver of data, and the SGM4594 becomes the transmitter.

The controller must send an ACK to the target at the end of every byte of data so that the target could send more data. The controller receives the number of bytes as expected, then it sends a NACK to the target to stop data transaction and release the SDA bus. After this, the controller sends a STOP condition.

If the command byte is not set through a write first, and a read is needed by the controller, the device NACKs until a command byte register address is set as described above.

See the **Control Register and Command Byte** section for more details. Figure 15 indicates the reading of a single byte from a target register.

The controller continues to supply the clock signal but releases the SDA so that the target can transmit data.

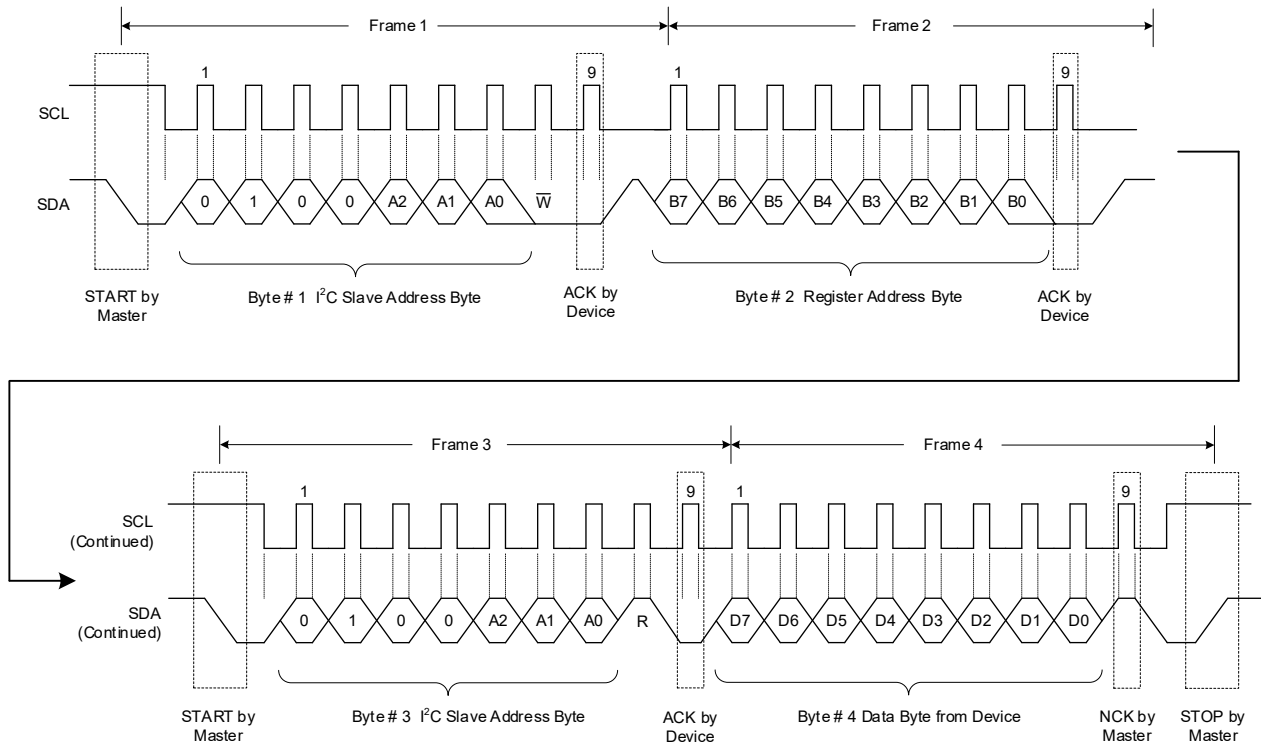

Figure 15. Read from Register

After a single write request to a register, a repeated start signal occurs, then the requested register is used for the read request. Note that when reading multiple bytes, the data is clocked into the register on the rising edge of the ACK signal pulse before data is transferred. After reading the first byte, other bytes may also be

read. However, the current data just reflects the information in the other register of the pair. For instance, if Input Port 0 is read, Input Port1 is read next. During read operation, if a RESTART occurs, the data may be lost due to that the internal register has already been changed to the other register of the pair.

DETAILED DESCRIPTION (continued)

The number of received data bytes in one read transmission has no limitation, but the controller must not acknowledge the data when the final byte is

received. Figure 16 and Figure 17 show two different scenarios.

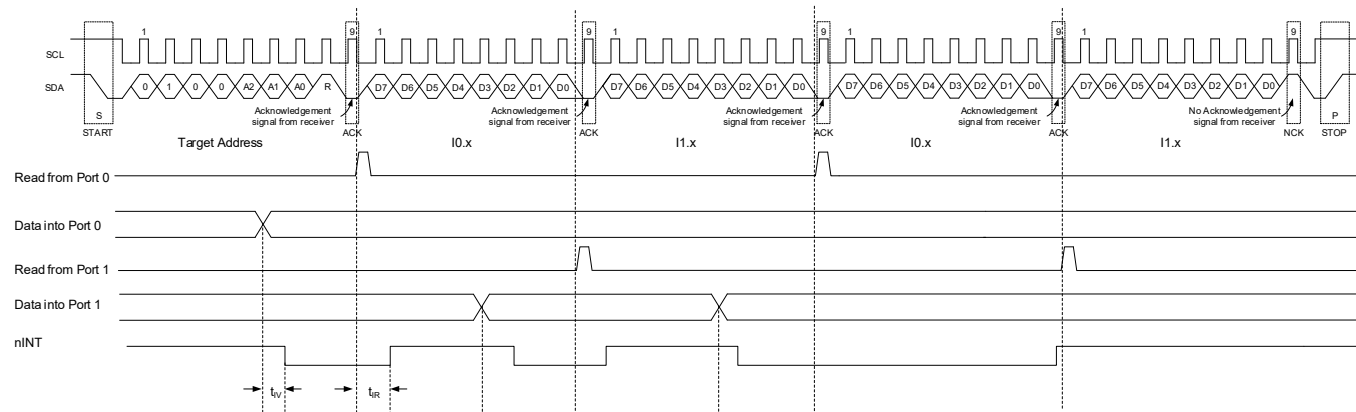

NOTES:

1. A STOP condition could stop data transaction at any time. Despite this, the data presented during the recent validation phase is valid (output mode), assuming that the command byte was previously set to 00.
2. This figure eliminates the command byte transfer, restart and target address call between the initial target address call and actual data transfer from P port (more details refer to READ).

Figure 16. Scenario 1 of Read Input Port Register

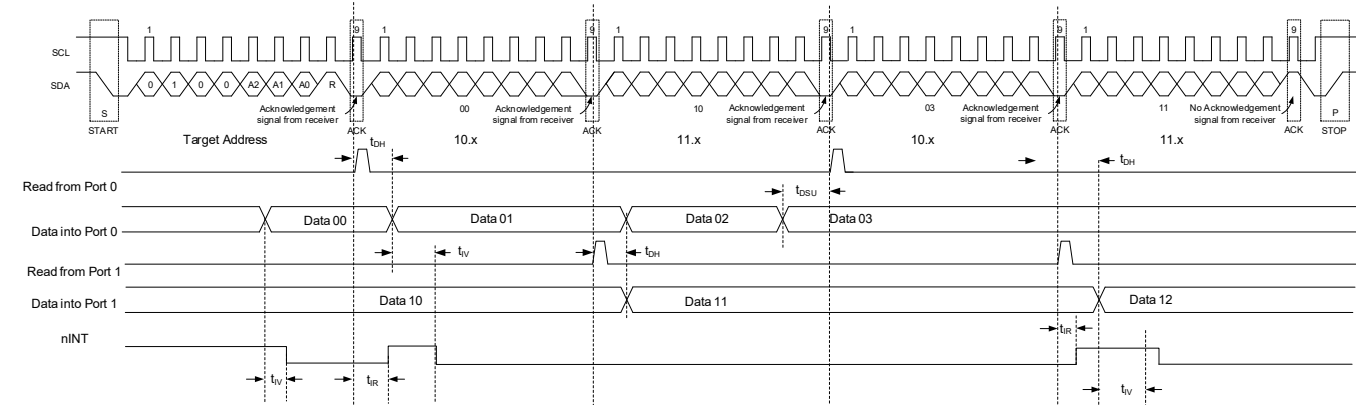

NOTES:

1. A STOP condition could stop data transaction at any time. Despite this, the data presented during the recent validation phase is valid (output mode), assuming that the command byte was previously set to 00.
2. This figure eliminates the command byte transfer, restart, and target address call between the initial target address call and actual data transfer from the P port (more details refer to READ).

Figure 17. Scenario 2 of Read Input Port Register

REGISTER MAPS

All registers are 8-bit and individual bits are named from D[7] (MSB) to D[0] (LSB).

I²C Register Address Map

Figure 18 shows the address byte of the SGM4594.

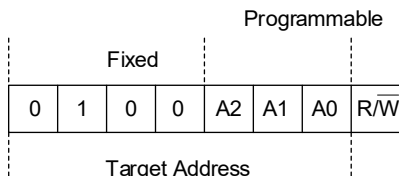

Figure 18. SGM4594 Address

Table 2 shows the address reference of the SGM4594.

Table 2. Address Reference

Parameter			I ² C Bus Target Address	
A2	A1	A0	Decimal	Hexadecimal
L	L	L	32	20
L	L	H	33	21
L	H	L	34	22
L	H	H	35	23
H	L	L	36	24
H	L	H	37	25
H	H	L	38	26
H	H	H	39	27

The last bit of the target address defines the read or write operation. 1 (high) performs the read operation, while 0 (low) performs the write operation.

Control Register and Command Byte

After acknowledging the address byte of target device successfully, the controller-transmitter would send a command byte stored in the control register. Four bits of the command byte state the operation (read or write) and the internal register (input, output, polarity inversion, configuration, output mode and output anomaly indication) that is affected. These registers support read or write operation via the I²C bus. Command bytes are sent only during write transmission.

After sending a command byte, the addressed register pair continues to be accessed by reads until a new command byte is sent. Figure 19 shows the control register bits.

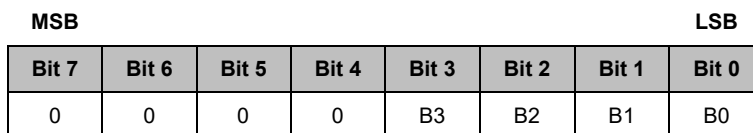

Figure 19. Control Register Bits

REGISTER MAPS (continued)**I²C Slave Register Addresses of SGM4594: 0x0X**

ADDRESS	REGISTER NAME	TYPE	D[7]	D[6]	D[5]	D[4]	D[3]	D[2]	D[1]	D[0]	
0x00	Input Port 0 Register	R	I0[7:0]								
0x01	Input Port 1 Register	R	I1[7:0]								
0x02	Output Port 0 Register	R/W	O0[7:0]								
0x03	Output Port 1 Register	R/W	O1[7:0]								
0x04	Polarity Inversion Port 0 Register	R/W	N0[7:0]								
0x05	Polarity Inversion Port 1 Register	R/W	N1[7:0]								
0x06	Configuration Port 0 Register	R/W	C0[7:0]								
0x07	Configuration Port 1 Register	R/W	C1[7:0]								
0x08	Output Mode Setting Port 0 Register	R/W	OC0[7:0]								
0x09	Output Mode Setting Port 1 Register	R/W	OC1[7:0]								
0x0A	Output Anomaly Indication Port 0 Register	R/W	OA0[7:0]								
0x0B	Output Anomaly Indication Port 1 Register	R/W	OA1[7:0]								

Bit Types:

R/W: Read/Write bit(s)

R: Read only bit(s)

RC: Bit(s) cleared to 0 by being read

PORV: Power-on Reset Value

n: Parameter code formed by the bits as an unsigned binary number.

REGISTER MAPS (continued)**REG0x00: Input Port 0 Register [Reset = 0xXX]**

BITS	BIT NAME	DEFAULT	TYPE	DESCRIPTION
D[7:0]	I0[7:0]	xxxx xxxx	R	This input port 0 register reflects the incoming logic levels of the corresponding pins. The register just only acts on the read operation, no matter whether the port pins are defined as I/O by the configuration port registers (REG0x06 and REG0x07). Writing to the two registers has no effect. The default value is set by the external port pins' logic level. Before a read operation, send a write transmission with a command byte to show the I ² C device that this register is accessed next.

REG0x01: Input Port 1 Register [Reset = 0xXX]

BITS	BIT NAME	DEFAULT	TYPE	DESCRIPTION
D[7:0]	I1[7:0]	xxxx xxxx	R	This input port 1 register reflects the incoming logic levels of the corresponding pins. The register just only acts on the read operation, no matter whether the port pins are defined as I/O by the configuration port registers (REG0x06 and REG0x07). Writing to the two registers has no effect. The default value is set by the external port pins' logic level. Before a read operation, send a write transmission with a command byte to show the I ² C device that this register is accessed next.

REG0x02: Output Port 0 Register [Reset = 0xFF]

BITS	BIT NAME	DEFAULT	TYPE	DESCRIPTION
D[7:0]	O0[7:0]	1111 1111	R/W	The output port 0 register reflects the outgoing logic levels of the corresponding pins defined as outputs by the configuration port registers (REG0x06 and REG0x07). The bit values in this register have no effect on the pins configured as input. Reading from the register reflects the value that is in the flip-flop controlling the output selection, not the actual pin value.

REG0x03: Output Port 1 Register [Reset = 0xFF]

BITS	BIT NAME	DEFAULT	TYPE	DESCRIPTION
D[7:0]	O1[7:0]	1111 1111	R/W	The output port 1 register reflects the outgoing logic levels of the corresponding pins defined as outputs by the configuration port registers (REG0x06 and REG0x07). The bit values in this register have no effect on the pins configured as input. Reading from the register reflects the value that is in the flip-flop controlling the output selection, not the actual pin value.

REG0x04: Polarity Inversion Port 0 Register [Reset = 0x00]

BITS	BIT NAME	DEFAULT	TYPE	DESCRIPTION
D[7:0]	N0[7:0]	0000 0000	R/W	The polarity inversion port 0 register allows polarity inversion of the corresponding port pins defined as input by the configuration port registers (REG0x06 and REG0x07). A bit in the register is written as '1', then the polarity of corresponding port pin is inverted. A bit in the register is written as '0', then the original polarity of corresponding port pin is retained.

REG0x05: Polarity Inversion Port 1 Register [Reset = 0x00]

BITS	BIT NAME	DEFAULT	TYPE	DESCRIPTION
D[7:0]	N1[7:0]	0000 0000	R/W	The polarity inversion port 1 register allows polarity inversion of the corresponding port pins defined as input by the configuration port registers (REG0x06 and REG0x07). A bit in the register is written as '1', then the polarity of corresponding port pin is inverted. A bit in the register is written as '0', then the original polarity of corresponding port pin is retained.

REGISTER MAPS (continued)**REG0x06: Configuration Port 0 Register [Reset = 0xFF]**

BITS	BIT NAME	DEFAULT	TYPE	DESCRIPTION
D[7:0]	C0[7:0]	1111 1111	R/W	The configuration port 0 register is used to configure the directions of the port pins. A bit in the register is written as '1', then the corresponding port pin is enabled as a high-impedance input. A bit in the register is written as '0', then the corresponding port pin is enabled as an output. The output mode can be set as push-pull or open-drain by the output mode setting registers (REG0x08 and REG0x09).

REG0x07: Configuration Port 1 Register [Reset = 0xFF]

BITS	BIT NAME	DEFAULT	TYPE	DESCRIPTION
D[7:0]	C1[7:0]	1111 1111	R/W	The configuration port 1 register is used to configure the directions of the port pins. A bit in the register is written as '1', then the corresponding port pin is enabled as a high-impedance input. A bit in the register is written as '0', then the corresponding port pin is enabled as an output. The output mode can be set as push-pull or open-drain by the output mode setting registers (REG0x08 and REG0x09).

REG0x08: Output Mode Setting Port 0 Register [Reset = 0xFF]

BITS	BIT NAME	DEFAULT	TYPE	DESCRIPTION
D[7:0]	OC0[7:0]	1111 1111	R/W	The output mode setting port 0 register can configure the output mode of port pins defined as outputs. A bit in the register is written as '1', then the corresponding port pin is configured as Push-Pull mode. A bit in the register is written as '0', then the corresponding port pin is configured as open-drain mode.

REG0x09: Output Mode Setting Port 1 Register [Reset = 0xFF]

BITS	BIT NAME	DEFAULT	TYPE	DESCRIPTION
D[7:0]	OC1[7:0]	1111 1111	R/W	The output mode setting port 1 register can configure the output mode of port pins defined as outputs. A bit in the register is written as '1', then the corresponding port pin is configured as Push-Pull mode. A bit in the register is written as '0', then the corresponding port pin is configured as open-drain mode.

REG0x0A: Output Anomaly Indication Port 0 Register [Reset = 0x00]

BITS	BIT NAME	DEFAULT	TYPE	DESCRIPTION
D[7:0]	OA0[7:0]	0000 0000	R/W	The output anomaly indication port 0 register sets the indication of nINT pin that occurring output short-circuit when the corresponding ports are set as push-pull output mode. The default value of each bit is '0', a bit in the register is written '1', then the corresponding output port pin would trigger an interrupt when its actual output level state differs from its corresponding output port register (REG0x02). When the actual output level state changes to match its corresponding output port register, the interrupt is reset. The reset that occurs when the processor reads the corresponding input port register would only occur once, and then the interrupt would not be triggered when the output anomaly occurs again. When a bit in the register is written '0', the corresponding port pin output anomaly indicator function is disabled. The nINT pin generates an interrupt whenever an input port changes state, regardless of what state the register is set to.

REGISTER MAPS (continued)**REG0x0B: Output Anomaly Indication Port 1 Register [Reset = 0x00]**

BITS	BIT NAME	DEFAULT	TYPE	DESCRIPTION
D[7:0]	OA1[7:0]	0000 0000	R/W	The output anomaly indication port 1 register sets the indication of nINT pin that occurring output short-circuit when the corresponding ports are set as push-pull output mode. The default value of each bit is '0', a bit in the register is written '1', then the corresponding output port pin would trigger an interrupt when its actual output level state differs from its corresponding output port register (REG0x03). When the actual output level state changes to match its corresponding output port registers, the interrupt is reset. The reset that occurs when the processor reads the corresponding input port register would only occur once, and then the interrupt would not be triggered when the output anomaly occurs again. When a bit in the register is written '0', the corresponding port pin output anomaly indicator function is disabled. The nINT pin generates an interrupt whenever an input port changes state, regardless of what state the register is set to.

APPLICATION INFORMATION

I/O expanders, such as SGM4594, are mainly used for LEDs control (for feedback or status lights), digital signals' enable/disable, and even output reading of other devices.

SGM4594 connects to an I²C bus as a target, and the bus may contain any other target devices. SGM4594 is usually placed remotely from the controller and close to the GPIO that the controller needs to monitor or control.

Design Requirements

Junction Temperature and Power Dissipation

In order to verify the safe operation of the device, the junction temperature of SGM4594 must be calculated due to many of the parameters are rated over junction temperature. Equation 1 shows the calculation of junction temperature.

$$T_J = T_A + (\theta_{JA} \times P_D) \quad (1)$$

θ_{JA} is the standard junction to ambient thermal resistance measurement of the package. P_D is the total power dissipation of the device. Equation 2 shows the approximate calculation.

$$P_D \approx (I_{CC_STATIC} \times V_{CC}) + \sum P_{D_PORT_L} + \sum P_{D_PORT_H} \quad (2)$$

The sum of static power and the power dissipated by each port are shown in Equation 2, which is an approximate value of power dissipation in the device. It should be noted that the power consumption of the nINT and SDA pins are ignored in this equation. If these transients are small, they are pulled down, then Equation 3 can easily include them in the power dissipation calculation, which gives the maximum power dissipation.

$$P_{D_PORT_L} = (I_{OL} \times V_{OL}) \quad (3)$$

The power consumption of a single port pin set to low output is shown in Equation 3. A port's power consumption is the V_{OL} of the port multiplied by its absorbed current.

$$P_{D_PORT_H} = [I_{OH} \times (V_{CC} - V_{OH})] \quad (4)$$

Equation 4 shows the power dissipation of a single port pin set to high output. The power consumed by a port is the current provided by the port multiplied by the voltage drop across the device (the difference between V_{CC} and output voltage).

Minimize I_{CC} when I/Os Control LEDs

Normally, an I/O used to control an LED is connected to V_{CC} through a resistor due to that the LED acts as a diode. The input voltage of an I/O is about 1.2V less than V_{CC} when the LED is off. In the applications powered by battery, for minimizing the current consumption when the LED is off, the I/O pin voltage should be greater than or equal to the supply voltage.

Figure 20 shows that a 100k Ω resistor is in parallel with the LED. As shown in Figure 21, V_{CC} is at least 1.2V lower than LED power supply voltage. Both the two ways can keep the supply voltage of an I/O equal to or above V_{CC} and prevent additional power current consumption when the LED is off.

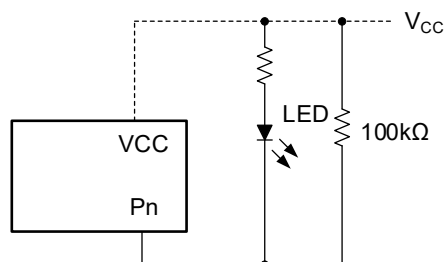

Figure 20. High-Value Resistor in Parallel with LED

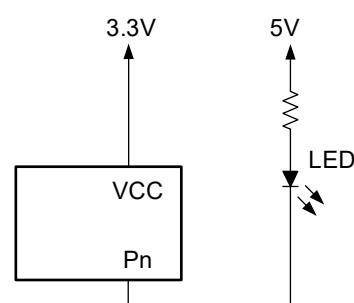

Figure 21. Device Supplied by Lower Voltage

APPLICATION INFORMATION (continued)

Power-on Reset (POR) Requirements

When a glitch or data corruption occurs, the power-on reset feature of the SGM4594 can be reset to the default conditions. The voltage waveform of POR is shown in Figure 22.

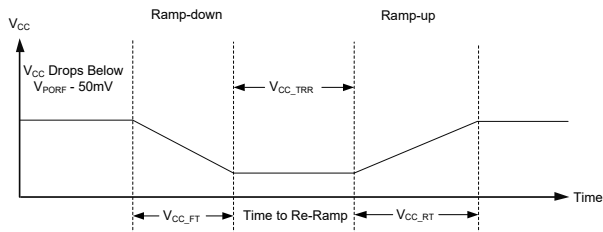

Figure 22. V_{CC} Lowered below the POR Threshold, then Ramped Back

The power glitch can also have an effect on the POR operation of SGM4594. The width and height of glitch are interdependent. The POR performance can also be affected by the bypass capacitance, source and device impedance, etc.

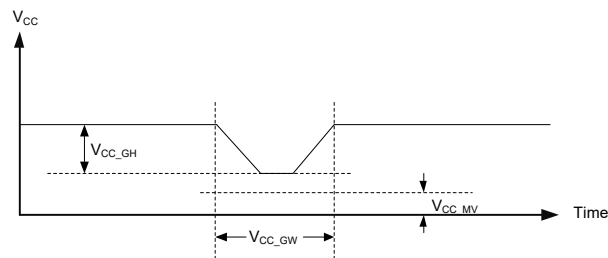

Figure 23. Width, Height and Minimum Voltage of Glitch

V_{POR} is the voltage which reset condition, registers, I²C and SMBus are rated, which is essential to POR. V_{POR} varies based on the supply voltage being reduced to or from 0V. Figure 24 and Table 3 show more details.

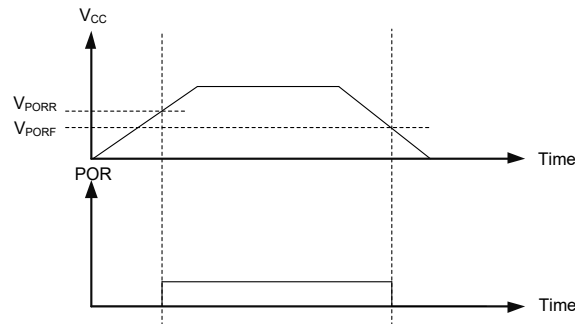

Figure 24. V_{POR}

Table 3 shows the performance of POR feature.

Table 3. Recommended Supply Sequence and Ramp Rates ⁽¹⁾

PARAMETER	SYMBOL	CONDITIONS	MIN	TYP	MAX	UNITS
Fall Rate ⁽²⁾	V _{CC_FT}	See Figure 22	0.75			ms
Rise Rate ⁽²⁾	V _{CC_RT}	See Figure 22	0.75			ms
Time to Re-Ramp (when V _{CC} drops to V _{POR_MIN} - 50mV or when V _{CC} drops to GND)	V _{CC_TRR}	See Figure 22	2			µs
The level (referenced to V _{CC}) that V _{CC} can glitch down to, but not cause a functional disruption when V _{CC_GW}	V _{CC_GH}	See Figure 23			1.2	V
The minimum voltage that V _{CC} can glitch down to without causing a reset (V _{CC_GH} must not be violated)	V _{CC_MV}	See Figure 23	1.55			V
Glitch Width that does not cause a functional disruption	V _{CC_GW}	See Figure 23			10	µs
Power-on Reset Voltage on Rising V _{CC}	V _{PORR}			1.2	1.5	V
Power-on Reset Voltage on Falling V _{CC}	V _{PORF}		0.6	1.0		V

NOTES:

1. T_A = -40°C to +125°C, unless otherwise noted.
2. Specified by design and characterization, not production tested.

APPLICATION INFORMATION (continued)

Layout Guidelines

The PCB layout of SGM4594 should follow the common layout guidelines, but other concerns about high-speed data transfer cannot affect the I²C signal speed, such as the differential pairs and the matched impedances.

Right angles should be avoided in signal traces in all PCB layouts. Fan out signal traces away from each other upon leaving the vicinity of the IC, and use trace with thicker width to carry the larger current that

normally passes through the power supply and ground traces. Bypass and decoupling capacitors are commonly used to control the voltage on V_{CC} pins. Larger capacitors are used to provide additional power in the case of a short-circuit power failure, and smaller capacitors are used to filter out high-frequency ripple. These capacitors must be put as close as possible to SGM4594.

REVISION HISTORY

NOTE: Page numbers for previous revisions may differ from page numbers in the current version.

Changes from Original to REV.A (FEBRUARY 2026)	Page
Changed from product preview to production data.....	All

PACKAGE INFORMATION

PACKAGE OUTLINE DIMENSIONS

TSSOP-24

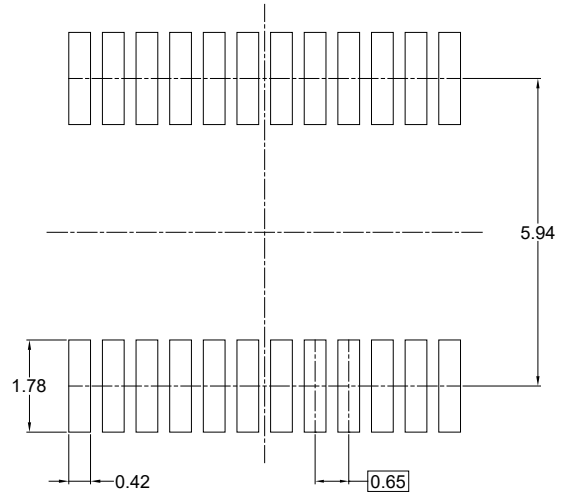
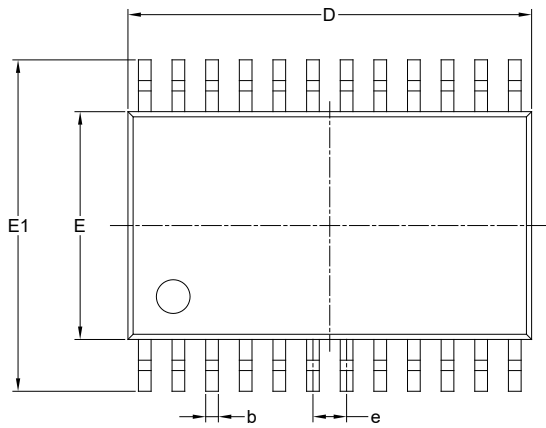

RECOMMENDED LAND PATTERN (Unit: mm)

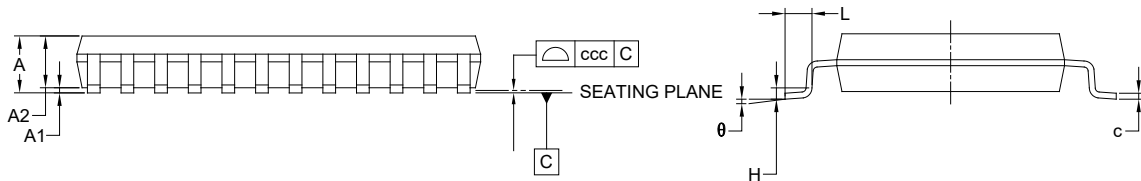

Symbol	Dimensions In Millimeters		
	MIN	NOM	MAX
A	-	-	1.200
A1	0.050	-	0.150
A2	0.800	-	1.050
b	0.190	-	0.300
c	0.090	-	0.200
D	7.700	-	7.900
E	4.300	-	4.500
E1	6.200	-	6.600
e	0.650 BSC		
L	0.450	-	0.750
H	0.250 TYP		
θ	0°	-	8°
ccc	0.100		

NOTES:

1. This drawing is subject to change without notice.
2. The dimensions do not include mold flashes, protrusions or gate burrs.
3. Reference JEDEC MO-153.

PACKAGE OUTLINE DIMENSIONS

TQFN-4x4-24FL

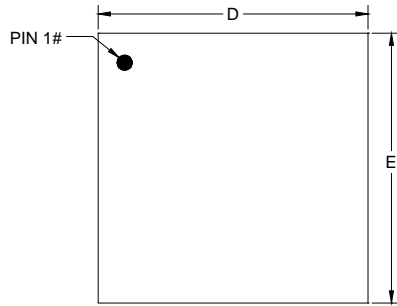

TOP VIEW

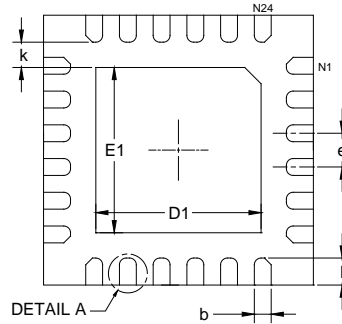

BOTTOM VIEW

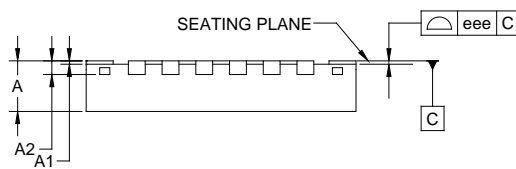

SIDE VIEW

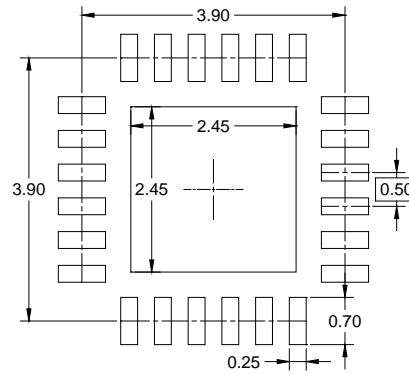

RECOMMENDED LAND PATTERN (Unit: mm)

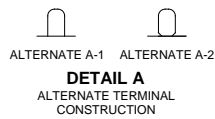

Symbol	Dimensions In Millimeters		
	MIN	NOM	MAX
A	0.700	-	0.800
A1	0.000	-	0.050
A2	0.203 REF		
b	0.180	-	0.300
D	3.900	-	4.100
D1	2.350	-	2.550
E	3.900	-	4.100
E1	2.350	-	2.550
e	0.500 BSC		
k	0.375 REF		
L	0.300	-	0.500
eee	0.080		

NOTE: This drawing is subject to change without notice.

TAPE AND REEL INFORMATION

REEL DIMENSIONS

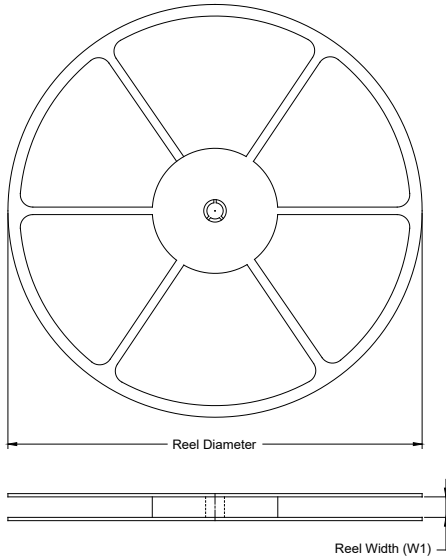

TAPE DIMENSIONS

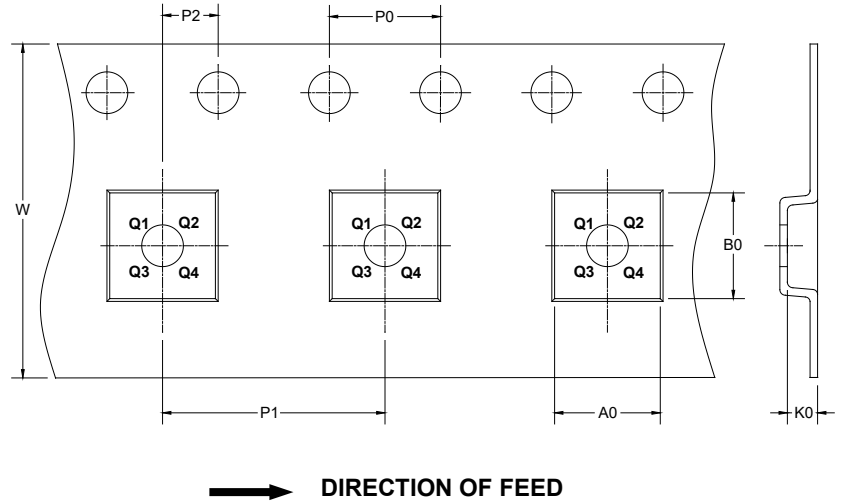

NOTE: The picture is only for reference. Please make the object as the standard.

KEY PARAMETER LIST OF TAPE AND REEL

Package Type	Reel Diameter	Reel Width W1 (mm)	A0 (mm)	B0 (mm)	K0 (mm)	P0 (mm)	P1 (mm)	P2 (mm)	W (mm)	Pin1 Quadrant
TSSOP-24	13"	16.4	6.80	8.30	1.60	4.0	8.0	2.0	16.0	Q1
TQFN-4×4-24FL	13"	12.4	4.30	4.30	1.10	4.0	8.0	2.0	12.0	Q2

DD0001

PACKAGE INFORMATION

CARTON BOX DIMENSIONS

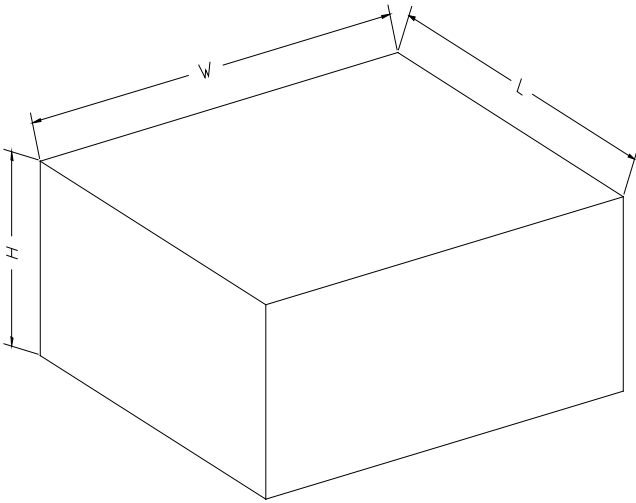

NOTE: The picture is only for reference. Please make the object as the standard.

KEY PARAMETER LIST OF CARTON BOX

Reel Type	Length (mm)	Width (mm)	Height (mm)	Pizza/Carton
13"	386	280	370	5

DD0002