

GENERAL DESCRIPTION

The SGM880 is a high accuracy voltage detector with very low supply current. It can be used under CMOS-based 36V input conditions and the absolute maximum voltage of supply voltage can come up to 45V, which can prevent circuit breakdown caused by transient over-voltage pulses. This device has a simple structure with a voltage reference, a comparator with hysteresis, a series of resistor divider and an N-channel output transistor.

The SGM880 has very low supply current. It can monitor voltage rails ranging from 2.3V to 12V with $\pm 0.7\%$ accuracy. The output pin (DOUT) is an N-channel active-low open-drain output.

The SGM880 is available in a Green SOT-23-5 package. Use of this package achieves high-density mounting on boards.

APPLICATIONS

- Voltage Monitoring for Electronic Control
- EV Inverter
- Battery Charge Control

TYPICAL APPLICATIONS

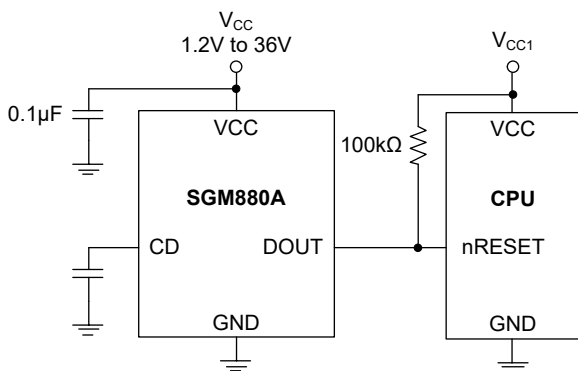

Figure 1. SGM880A Typical Application Circuit

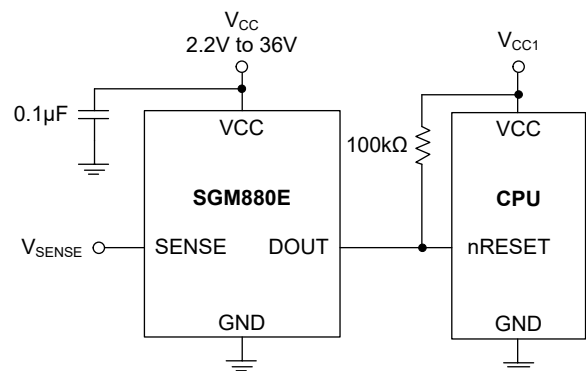

Figure 2. SGM880E Typical Application Circuit

FEATURES

- **Operating Voltage Range:**
 - ◆ SGM880A: 1.2V to 36V
 - ◆ SGM880E: 2.2V to 36V
- **Low Supply Current**
 - ◆ SGM880A: 3.0µA (TYP)
 - ◆ SGM880E: 2.3µA (TYP)
- **Detector Threshold Range: 2.3V to 5.0V (0.1V Increments), 5.0V to 12.0V (0.25V Increments)**
- **Detector Threshold Accuracy: $\pm 0.7\%$ at +25°C**
- **Voltage Detection Type:**
 - ◆ SGM880A: with CD Pin Type
 - ◆ SGM880E: with SENSE Pin Type
- **Detector Threshold Temperature Coefficient: 40ppm/°C**
- **Release Output Delay Time (SGM880A Only)**
 - ◆ 90ms at $C_D = 0.01\mu F$
 - ◆ $\pm 39\%$ Accuracy
- **Open-Drain Output**
- **Available in a Green SOT-23-5 Package**

PACKAGE/ORDERING INFORMATION

MODEL	PACKAGE DESCRIPTION	SPECIFIED TEMPERATURE RANGE	ORDERING NUMBER	PACKAGE MARKING	PACKING OPTION
SGM880A-2.3	SOT-23-5	-40°C to +125°C	SGM880A-2.3XN5G/TR	1BC XXXXX	Tape and Reel, 3000
SGM880A-2.5	SOT-23-5	-40°C to +125°C	SGM880A-2.5XN5G/TR	1BD XXXXX	Tape and Reel, 3000
SGM880A-3.0	SOT-23-5	-40°C to +125°C	SGM880A-3.0XN5G/TR	1BE XXXXX	Tape and Reel, 3000
SGM880A-4.3	SOT-23-5	-40°C to +125°C	SGM880A-4.3XN5G/TR	1BF XXXXX	Tape and Reel, 3000
SGM880A-4.6	SOT-23-5	-40°C to +125°C	SGM880A-4.6XN5G/TR	1BG XXXXX	Tape and Reel, 3000
SGM880A-5.0	SOT-23-5	-40°C to +125°C	SGM880A-5.0XN5G/TR	1BH XXXXX	Tape and Reel, 3000
SGM880A-5.5	SOT-23-5	-40°C to +125°C	SGM880A-5.5XN5G/TR	1BI XXXXX	Tape and Reel, 3000
SGM880A-7.5	SOT-23-5	-40°C to +125°C	SGM880A-7.5XN5G/TR	1BJ XXXXX	Tape and Reel, 3000
SGM880A-9.0	SOT-23-5	-40°C to +125°C	SGM880A-9.0XN5G/TR	1BK XXXXX	Tape and Reel, 3000
SGM880A-11.5	SOT-23-5	-40°C to +125°C	SGM880A-11.5XN5G/TR	1BL XXXXX	Tape and Reel, 3000
SGM880A-12.0	SOT-23-5	-40°C to +125°C	SGM880A-12.0XN5G/TR	1BM XXXXX	Tape and Reel, 3000
SGM880E-2.3	SOT-23-5	-40°C to +125°C	SGM880E-2.3XN5G/TR	1BN XXXXX	Tape and Reel, 3000
SGM880E-2.5	SOT-23-5	-40°C to +125°C	SGM880E-2.5XN5G/TR	1BO XXXXX	Tape and Reel, 3000
SGM880E-3.0	SOT-23-5	-40°C to +125°C	SGM880E-3.0XN5G/TR	1BP XXXXX	Tape and Reel, 3000
SGM880E-4.3	SOT-23-5	-40°C to +125°C	SGM880E-4.3XN5G/TR	1BQ XXXXX	Tape and Reel, 3000
SGM880E-4.6	SOT-23-5	-40°C to +125°C	SGM880E-4.6XN5G/TR	1BR XXXXX	Tape and Reel, 3000
SGM880E-5.0	SOT-23-5	-40°C to +125°C	SGM880E-5.0XN5G/TR	1BS XXXXX	Tape and Reel, 3000
SGM880E-5.5	SOT-23-5	-40°C to +125°C	SGM880E-5.5XN5G/TR	1BT XXXXX	Tape and Reel, 3000
SGM880E-7.5	SOT-23-5	-40°C to +125°C	SGM880E-7.5XN5G/TR	1BU XXXXX	Tape and Reel, 3000
SGM880E-9.0	SOT-23-5	-40°C to +125°C	SGM880E-9.0XN5G/TR	1BV XXXXX	Tape and Reel, 3000
SGM880E-11.5	SOT-23-5	-40°C to +125°C	SGM880E-11.5XN5G/TR	1BW XXXXX	Tape and Reel, 3000
SGM880E-12.0	SOT-23-5	-40°C to +125°C	SGM880E-12.0XN5G/TR	1BX XXXXX	Tape and Reel, 3000

NOTE: For more models not listed above, please contact your local SGMICRO sales representatives.

MARKING INFORMATION

NOTE: XXXXX = Date Code, Trace Code and Vendor Code.

XXXXX

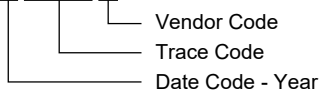

Green (RoHS & HSF): SG Micro Corp defines "Green" to mean Pb-Free (RoHS compatible) and free of halogen substances. If you have additional comments or questions, please contact your SGMICRO representative directly.

DEVICE NAMING DESCRIPTION

SGM880 x - x

Voltage Detection Type Options $\xrightarrow{\quad}$ $\xrightarrow{\quad}$ Nominal Threshold Options

Voltage Detection Type Options							
A	CD Pin Type			E	SENSE Pin Type		
Nominal Monitor Threshold Voltage Options							
2.3	2.3V	3.7	3.7V	5.25	5.25V	8.75	8.75V
2.4	2.4V	3.8	3.8V	5.5	5.5V	9.0	9.0V
2.5	2.5V	3.9	3.9V	5.75	5.75V	9.25	9.25V
2.6	2.6V	4.0	4.0V	6.0	6.0V	9.5	9.5V
2.7	2.7V	4.1	4.1V	6.25	6.25V	9.75	9.75V
2.8	2.8V	4.2	4.2V	6.5	6.5V	10.0	10.0V
2.9	2.9V	4.3	4.3V	6.75	6.75V	10.25	10.25V
3.0	3.0V	4.4	4.4V	7.0	7.0V	10.5	10.5V
3.1	3.1V	4.5	4.5V	7.25	7.25V	10.75	10.75V
3.2	3.2V	4.6	4.6V	7.5	7.5V	11.0	11.0V
3.3	3.3V	4.7	4.7V	7.75	7.75V	11.25	11.25V
3.4	3.4V	4.8	4.8V	8.0	8.0V	11.5	11.5V
3.5	3.5V	4.9	4.9V	8.25	8.25V	11.75	11.75V
3.6	3.6V	5.0	5.0V	8.5	8.5V	12.0	12.0V

ABSOLUTE MAXIMUM RATINGS

Supply Voltage Range, V_{CC}
 SGM880A -0.3V to 45V
 SGM880E -0.3V to 45V
 DOUT Pin Output Voltage, V_{DOUT} -0.3V to 7V
 CD Pin Output Voltage, V_{CD} (SGM880A) -0.3V to 7V
 SENSE Pin Input Voltage, V_{SENSE} (SGM880E) .. -0.3V to 50V
 DOUT Pin Output Current, I_{DOUT} 20mA
 Package Thermal Resistance
 SOT-23-5, θ_{JA} 142.6°C/W
 SOT-23-5, θ_{JB} 30.3°C/W
 SOT-23-5, θ_{JC} 55.0°C/W
 Junction Temperature +150°C
 Storage Temperature Range -65°C to +150°C
 Lead Temperature (Soldering, 10s) +260°C
 ESD Susceptibility ⁽¹⁾⁽²⁾
 HBM ±4000V
 CDM ±1000V

NOTES:

1. For human body model (HBM), all pins comply with ANSI/ESDA/JEDEC JS-001 specifications.
2. For charged device model (CDM), all pins comply with ANSI/ESDA/JEDEC JS-002 specifications.

RECOMMENDED OPERATING CONDITIONS

Operating Voltage Range, V_{CC}
 SGM880A 1.2V to 36V
 SGM880E 2.2V to 36V
 SENSE Pin Voltage, V_{SENSE} (SGM880E) 0V to 36V
 Operating Temperature Range -40°C to +125°C

OVERSTRESS CAUTION

Stresses beyond those listed in Absolute Maximum Ratings may cause permanent damage to the device. Exposure to absolute maximum rating conditions for extended periods may affect reliability. Functional operation of the device at any conditions beyond those indicated in the Recommended Operating Conditions section is not implied.

ESD SENSITIVITY CAUTION

This integrated circuit can be damaged by ESD if you don't pay attention to ESD protection. SGMICRO recommends that all integrated circuits be handled with appropriate precautions. Failure to observe proper handling and installation procedures can cause damage. ESD damage can range from subtle performance degradation to complete device failure. Precision integrated circuits may be more susceptible to damage because very small parametric changes could cause the device not to meet its published specifications.

DISCLAIMER

SG Micro Corp reserves the right to make any change in circuit design, or specifications without prior notice.

PIN CONFIGURATIONS

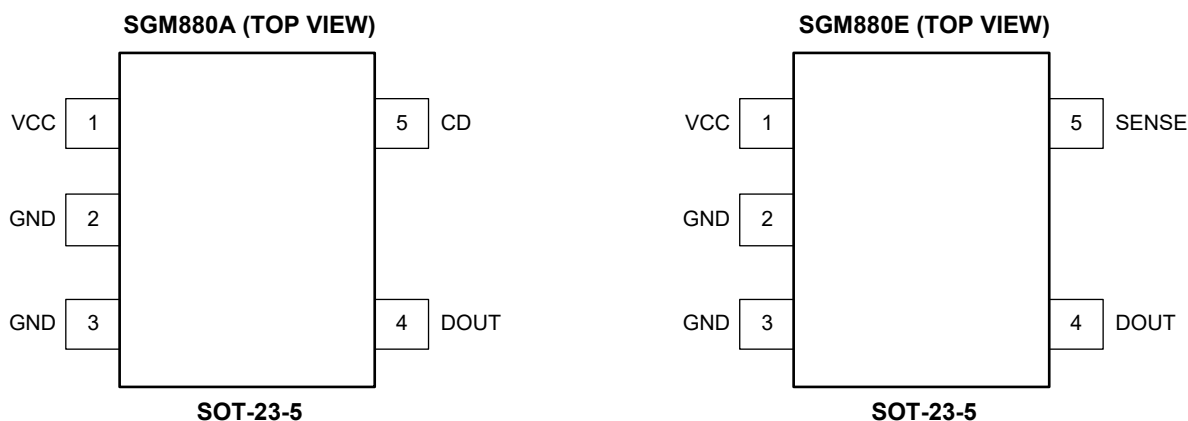

PIN DESCRIPTION

PIN	NAME	FUNCTION
1	VCC	Input Supply Voltage Pin.
2, 3	GND	Ground. The GND pins must be wired to the GND plane when mounted on board.
4	DOUT	Active-Low Open-Drain Output Pin.
5	CD	Release Output Delay Set Pin (SGM880A).
	SENSE	Voltage SENSE Pin (SGM880E).

ELECTRICAL CHARACTERISTICS

(Pull up to 5V with a 100kΩ resistor, $T_A = -40^\circ\text{C}$ to $+125^\circ\text{C}$, typical values are measured at $T_A = +25^\circ\text{C}$, unless otherwise noted.)

PARAMETER	SYMBOL	CONDITIONS	MIN	TYP	MAX	UNITS
SGM880A						
Detector Threshold	$-V_{\text{DET}}$	VCC pin, $T_A = +25^\circ\text{C}$	-0.7		0.7	%
		VCC pin, $T_A = -40^\circ\text{C}$ to $+85^\circ\text{C}$	-1.5		1.5	
		VCC pin, $T_A = -40^\circ\text{C}$ to $+125^\circ\text{C}$	-2.0		1.5	
Detector Threshold Hysteresis	V_{HYS}		3.9	5.2	6.5	%
Supply Current	I_{SS}	$V_{\text{CC}} = 13.2\text{V}$		3.0	5.5	μA
Minimum Operating Voltage ⁽¹⁾	V_{CCL}	VCC pin, $T_A = +25^\circ\text{C}$			1.05	V
		VCC pin, $T_A = -40^\circ\text{C}$ to $+125^\circ\text{C}$			1.2	
Output Current (N-ch. Driver Output Pin)	I_{DOUT}	$V_{\text{CC}} = 1.5\text{V}$, $V_{\text{DOUT}} = 0.05\text{V}$	400			μA
DOUT Low-Level Voltage	V_{OL}	$V_{\text{CC}} = 2.2\text{V}$, $I_{\text{SINK}} = 3.5\text{mA}$			0.3	V
N-ch. Driver Leakage Current	I_{LEAK}	$V_{\text{CC}} = 36\text{V}$, $V_{\text{DOUT}} = 6\text{V}$			0.3	μA
Release Output Delay Time	t_{DELAY}	$V_{\text{CC}} = 2.1\text{V}$ to $-V_{\text{DET}} + 2\text{V}$, $C_{\text{D}} = 0.01\mu\text{F}$, $T_A = +25^\circ\text{C}$	65	90	115	ms
		$V_{\text{CC}} = 2.1\text{V}$ to $-V_{\text{DET}} + 2\text{V}$, $C_{\text{D}} = 0.01\mu\text{F}$, $T_A = -40^\circ\text{C}$ to $+125^\circ\text{C}$	55	90	125	
Detect Output Delay Time	t_{RESET}	$V_{\text{CC}} = -V_{\text{DET}} + 2\text{V}$ to 2.1V , $-V_{\text{DET}} = 2.3\text{V}$		26		μs
		$V_{\text{CC}} = -V_{\text{DET}} + 2\text{V}$ to 2.1V , $-V_{\text{DET}} = 5.5\text{V}$		18		
		$V_{\text{CC}} = -V_{\text{DET}} + 2\text{V}$ to 2.1V , $-V_{\text{DET}} = 12\text{V}$		16		
SGM880E						
Detector Threshold	$-V_{\text{DET}}$	SENSE Pin, $V_{\text{CC}} = 6\text{V}$, $T_A = +25^\circ\text{C}$	-0.7		0.7	%
		SENSE Pin, $V_{\text{CC}} = 6\text{V}$, $T_A = -40^\circ\text{C}$ to $+85^\circ\text{C}$	-1.5		1.5	
		SENSE Pin, $V_{\text{CC}} = 6\text{V}$, $T_A = -40^\circ\text{C}$ to $+125^\circ\text{C}$	-2.0		1.5	
Detector Threshold Hysteresis	V_{HYS}		3.9	5.2	6.5	%
Supply Current	I_{SS}	$V_{\text{CC}} = 6\text{V}$		2.0	5.0	μA
		$V_{\text{CC}} = 36\text{V}$		2.3	5.5	
Under-Voltage Lockout ⁽²⁾	V_{UVLO}				2.2	V
SENSE Resistance	R_{SENSE}		4.5		45	$\text{M}\Omega$
Output Current (N-ch. Driver Output Pin)	I_{DOUT}	$V_{\text{SENSE}} < -V_{\text{DET}}$, $V_{\text{CC}} = 2.1\text{V}$, $V_{\text{DOUT}} = 0.05\text{V}$	600			μA
DOUT Low-Level Voltage	V_{OL}	$V_{\text{CC}} = 2.2\text{V}$, $I_{\text{SINK}} = 3.5\text{mA}$			0.3	V
N-ch. Driver Leakage Current	I_{LEAK}	$V_{\text{CC}} = 6\text{V}$, $V_{\text{SENSE}} = 36\text{V}$, $V_{\text{DOUT}} = 6\text{V}$			0.3	μA
Release Output Delay Time	t_{DELAY}	$V_{\text{CC}} = 6\text{V}$, $V_{\text{SENSE}} = 2.1\text{V}$ to $-V_{\text{DET}} + 2\text{V}$, $-V_{\text{DET}} = 2.3\text{V}$		16		μs
		$V_{\text{CC}} = 6\text{V}$, $V_{\text{SENSE}} = 2.1\text{V}$ to $-V_{\text{DET}} + 2\text{V}$, $-V_{\text{DET}} = 5.5\text{V}$		20		
		$V_{\text{CC}} = 6\text{V}$, $V_{\text{SENSE}} = 2.1\text{V}$ to $-V_{\text{DET}} + 2\text{V}$, $-V_{\text{DET}} = 12\text{V}$		19		
Detect Output Delay Time	t_{RESET}	$V_{\text{CC}} = 6\text{V}$, $V_{\text{SENSE}} = -V_{\text{DET}} + 2\text{V}$ to 2.1V , $-V_{\text{DET}} = 2.3\text{V}$		26		μs
		$V_{\text{CC}} = 6\text{V}$, $V_{\text{SENSE}} = -V_{\text{DET}} + 2\text{V}$ to 2.1V , $-V_{\text{DET}} = 5.5\text{V}$		16		
		$V_{\text{CC}} = 6\text{V}$, $V_{\text{SENSE}} = -V_{\text{DET}} + 2\text{V}$ to 2.1V , $-V_{\text{DET}} = 12\text{V}$		15		

NOTES:

- The value is the minimum operating voltage when the output voltage is 0.1V or less at detection.
- During power-on, V_{CC} must exceed V_{UVLO} for at least 2ms to finish the startup procedure.

ELECTRICAL CHARACTERISTICS (continued)

Timing Diagram

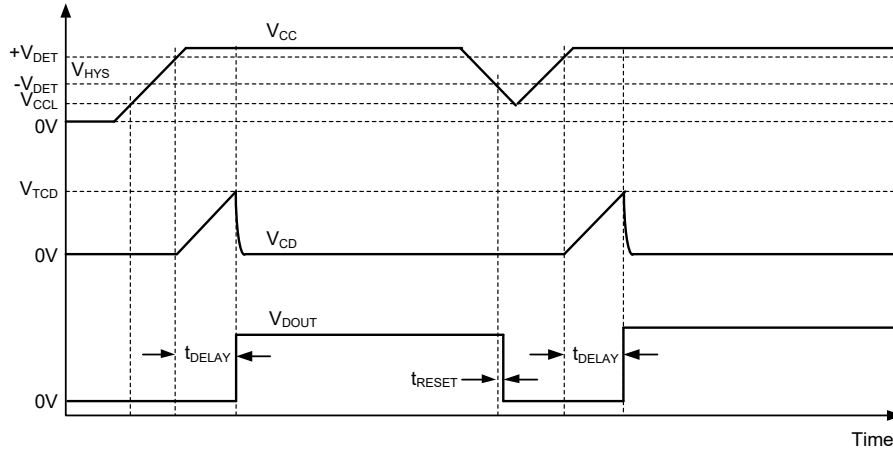

NOTE: DOUT is pulled up to VCC through a 100kΩ resistor.

Figure 3. SGM880A Timing Diagram

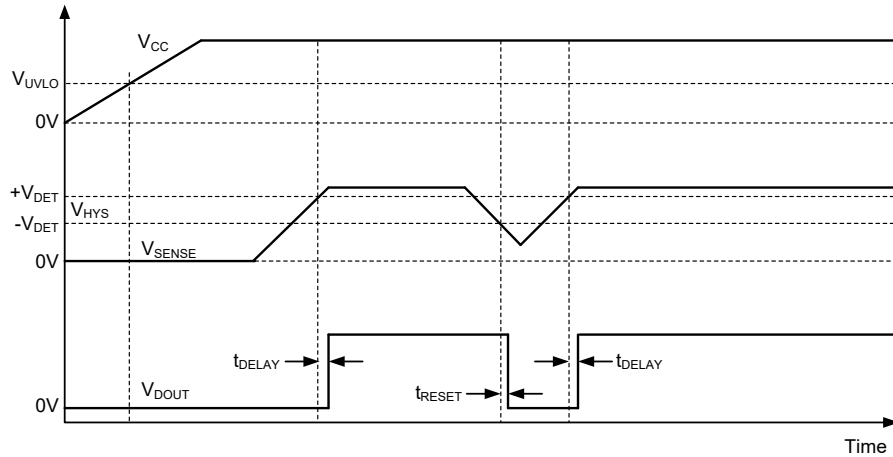

NOTE: DOUT is pulled up to VCC through a 100kΩ resistor.

Figure 4. SGM880E Timing Diagram

Voltage Chart

PRODUCT NAME	-V _{DET} (V), T _A = +25°C			-V _{DET} (V), T _A = -40°C to +125°C		
	MIN	TYP	MAX	MIN	TYP	MAX
SGM880A/E-2.3	2.284	2.300	2.316	2.254	2.300	2.335
SGM880A/E-2.5	2.483	2.500	2.518	2.450	2.500	2.538
SGM880A/E-3.0	2.979	3.000	3.021	2.940	3.000	3.045
SGM880A/E-4.3	4.270	4.300	4.330	4.214	4.300	4.365
SGM880A/E-4.6	4.568	4.600	4.632	4.508	4.600	4.669
SGM880A/E-5.0	4.965	5.000	5.035	4.900	5.000	5.075
SGM880A/E-5.5	5.462	5.500	5.539	5.390	5.500	5.583
SGM880A/E-7.5	7.448	7.500	7.553	7.350	7.500	7.613
SGM880A/E-9.0	8.937	9.000	9.063	8.820	9.000	9.135
SGM880A/E-11.5	11.420	11.500	11.581	11.270	11.500	11.673
SGM880A/E-12.0	11.916	12.000	12.084	11.760	12.000	12.180

TYPICAL PERFORMANCE CHARACTERISTICS

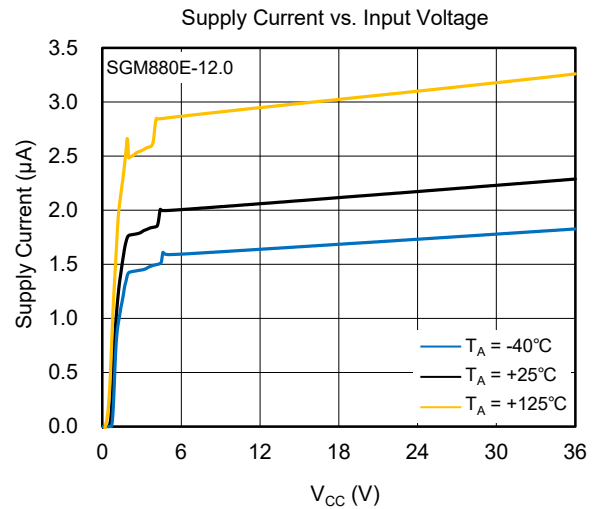
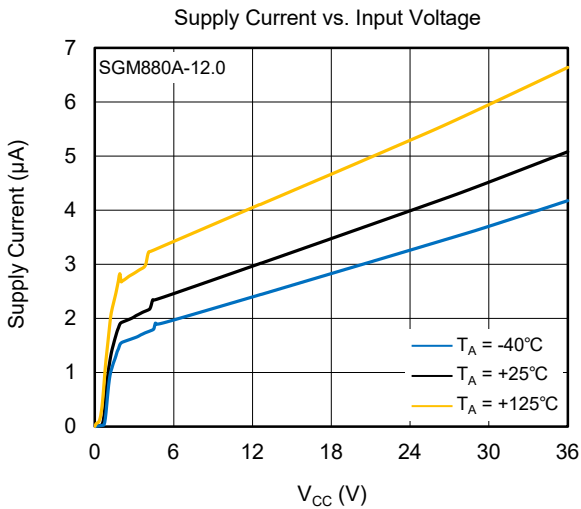
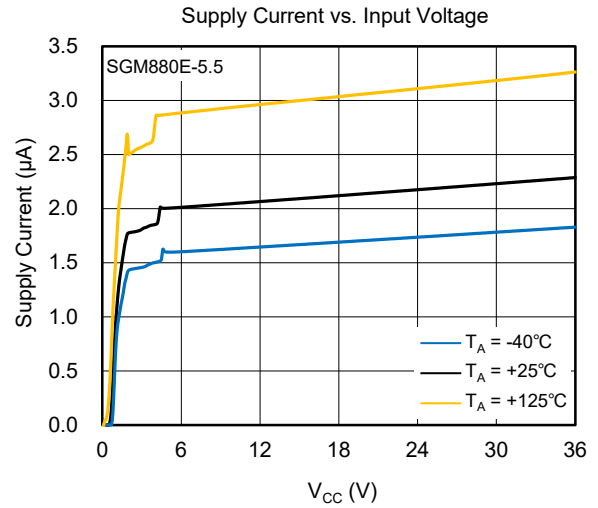
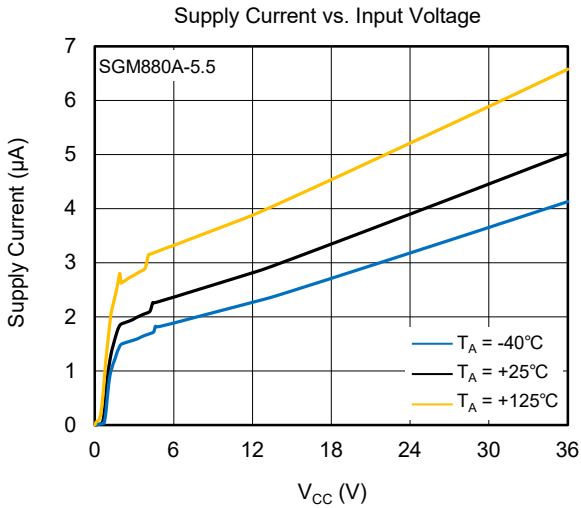
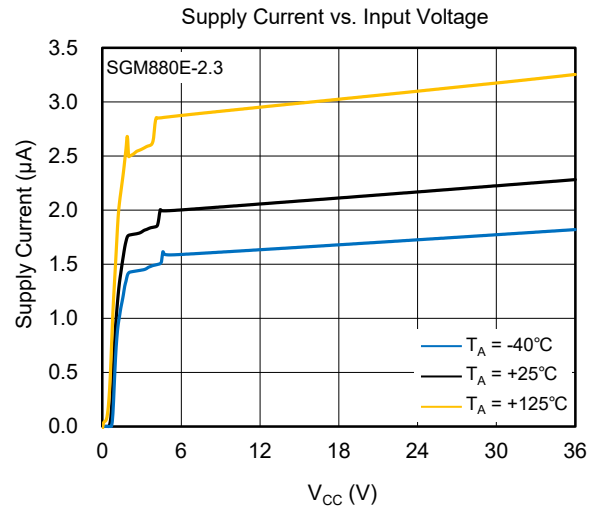
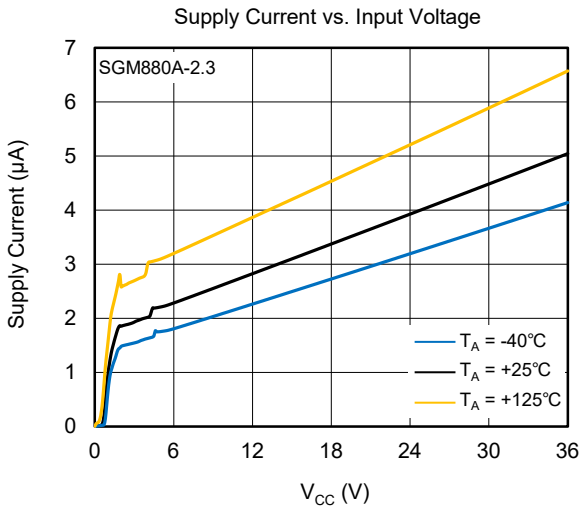

TYPICAL PERFORMANCE CHARACTERISTICS (continued)

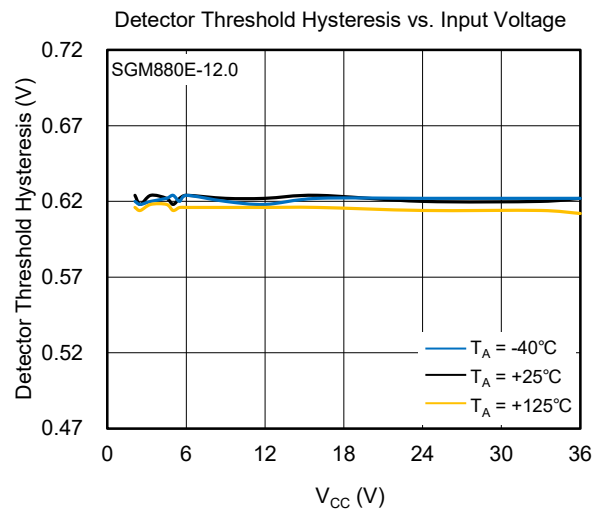
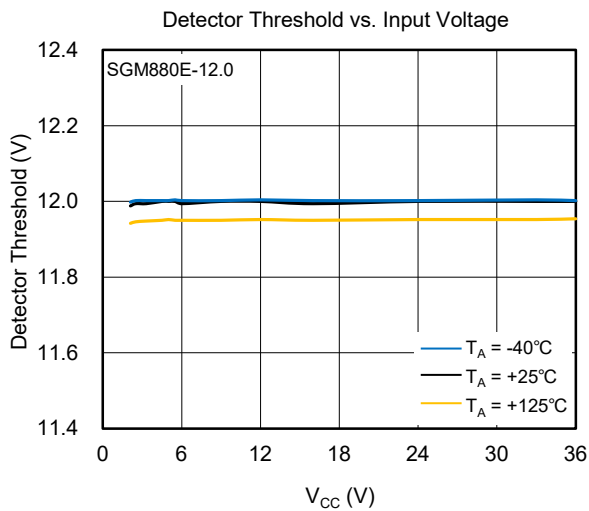
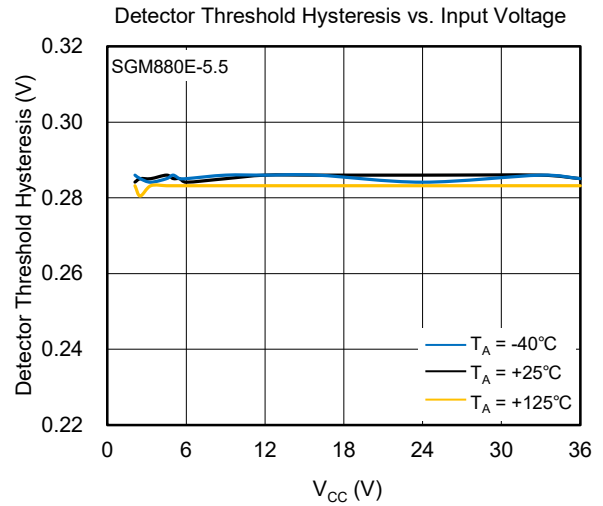
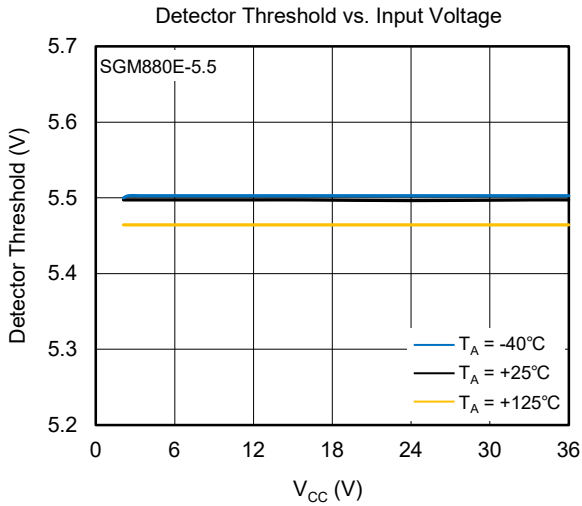
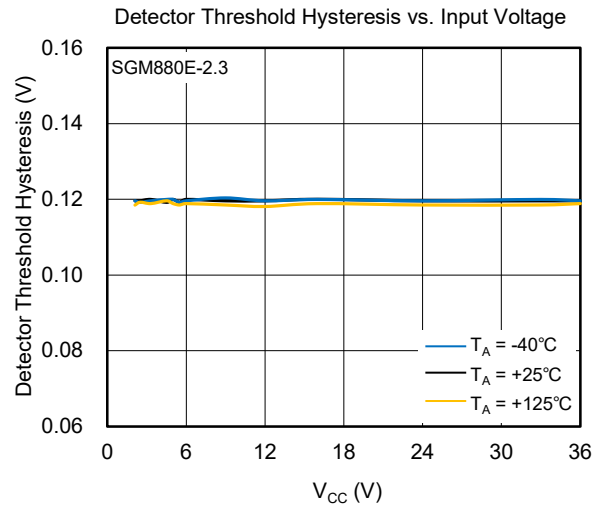
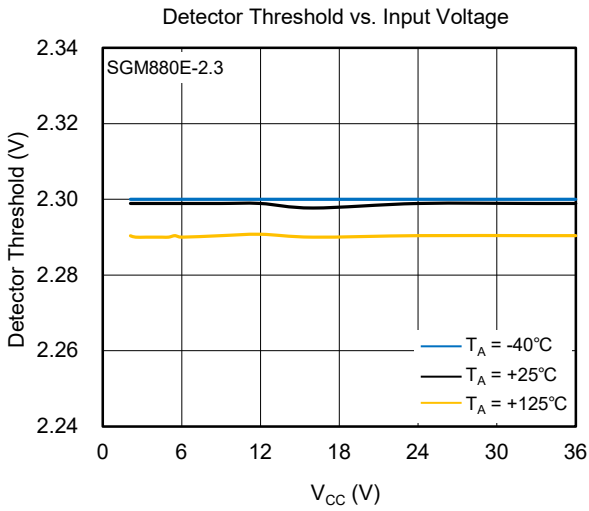

TYPICAL PERFORMANCE CHARACTERISTICS (continued)

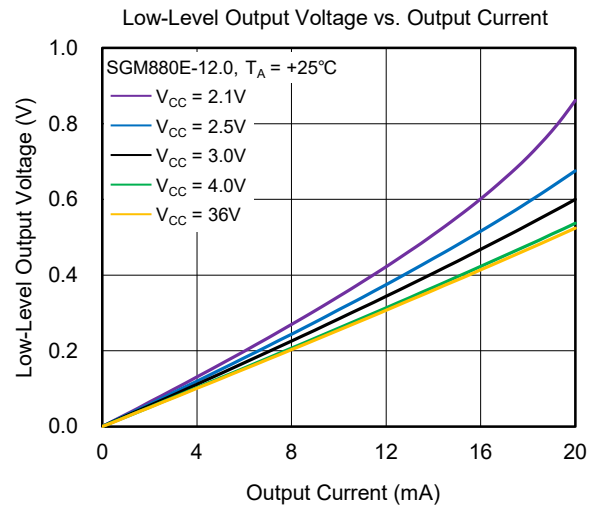
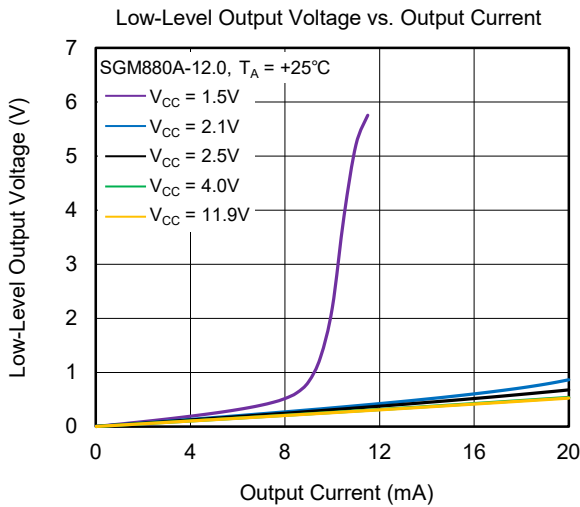
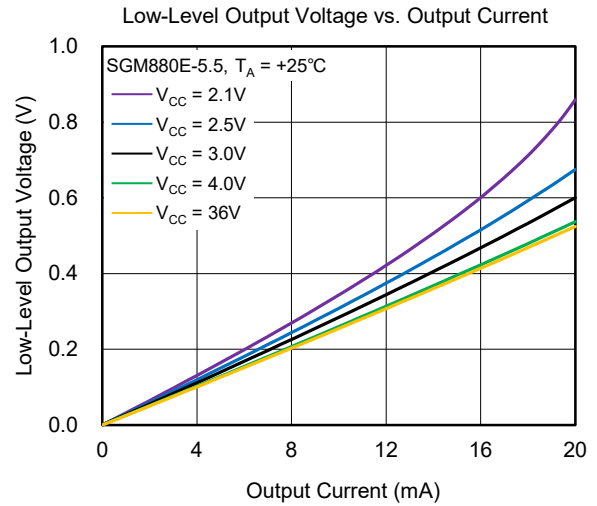
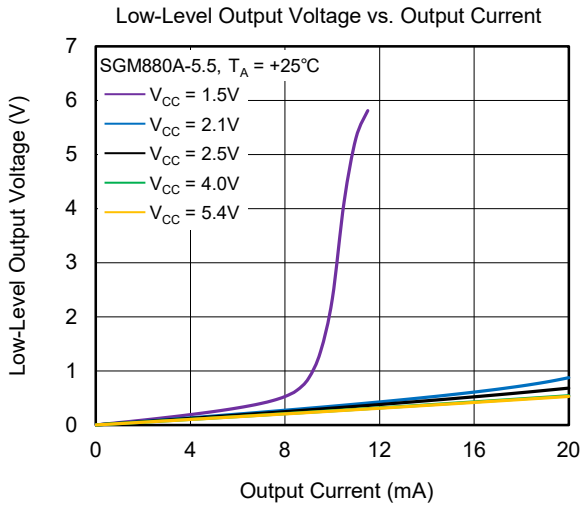
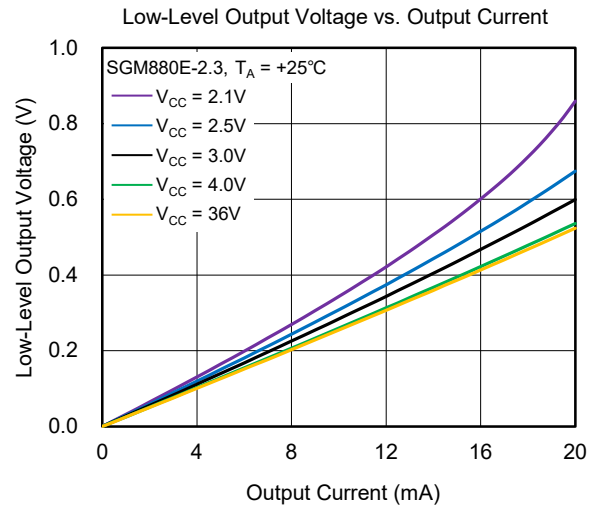
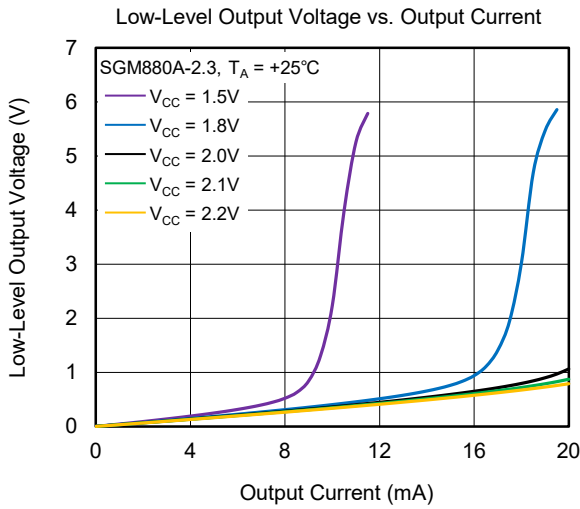

TYPICAL PERFORMANCE CHARACTERISTICS (continued)

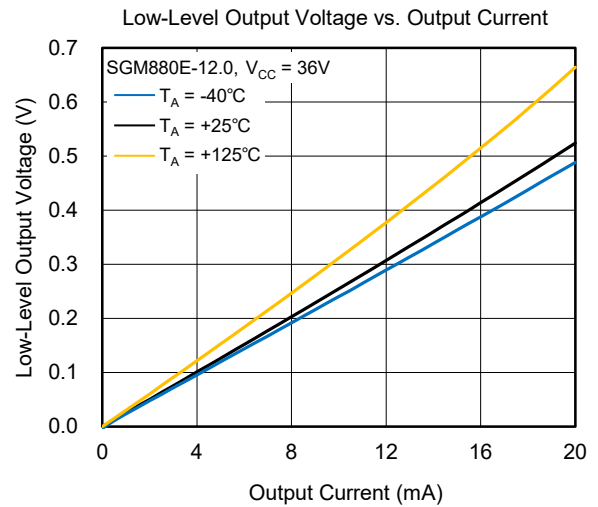
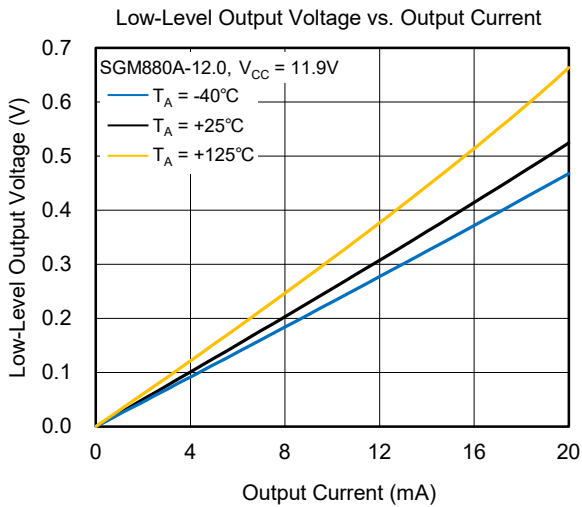
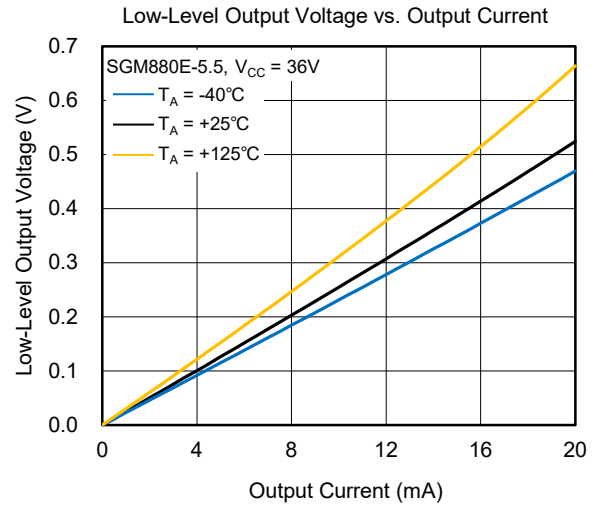
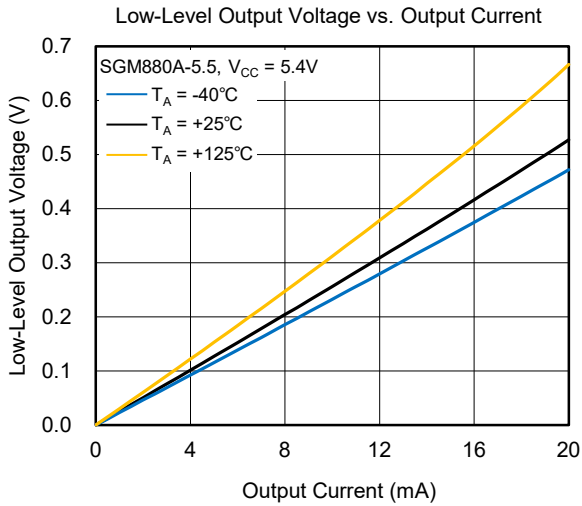
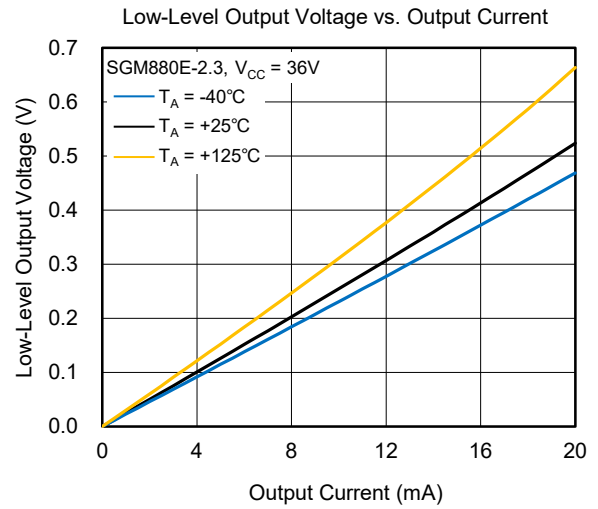
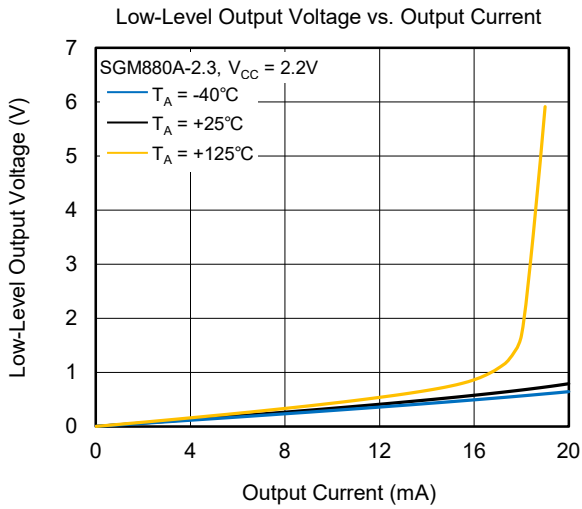

TYPICAL PERFORMANCE CHARACTERISTICS (continued)

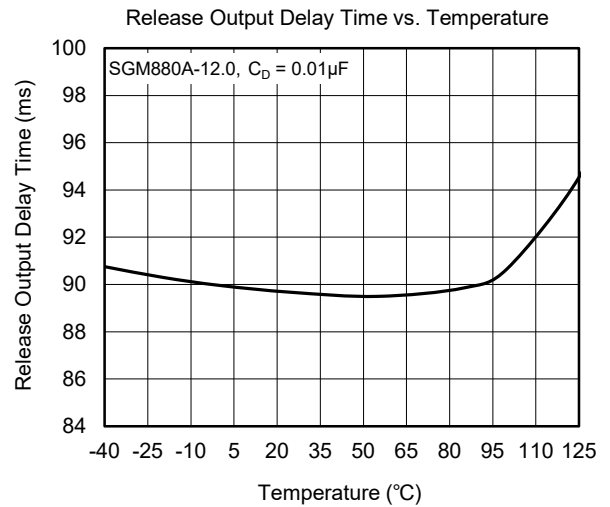
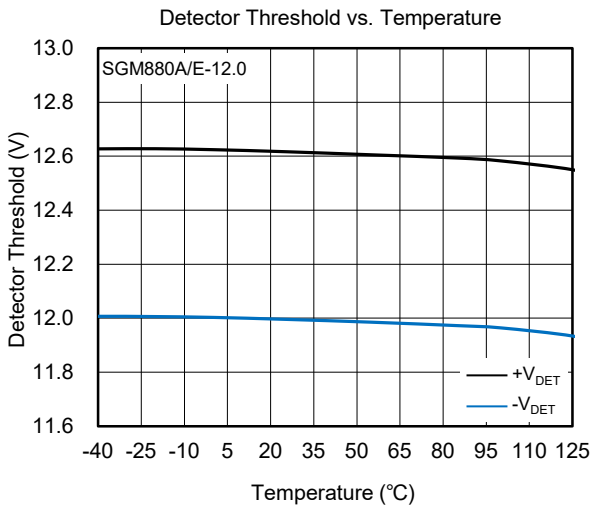
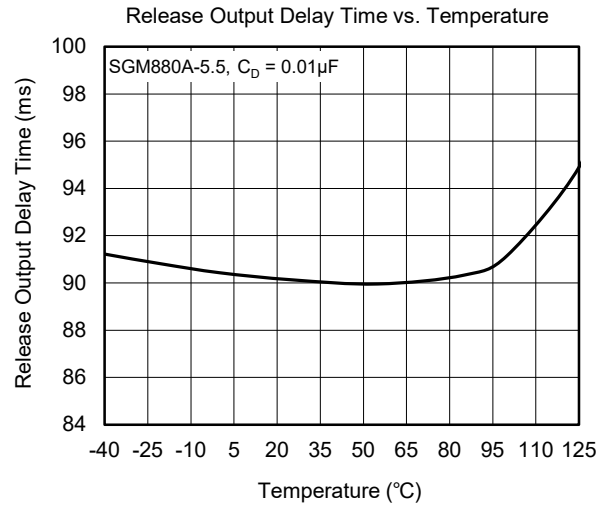
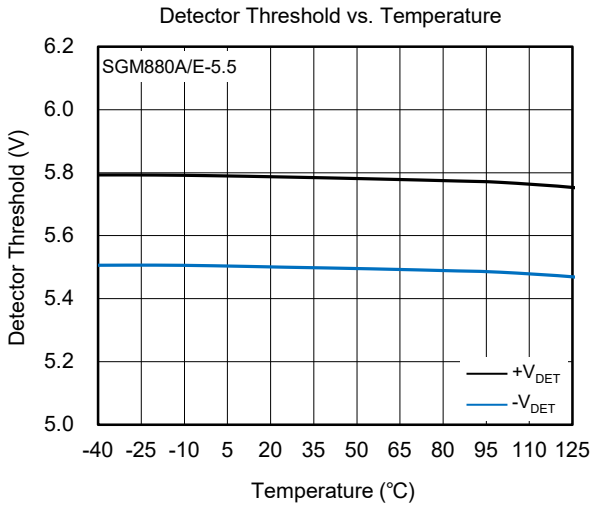
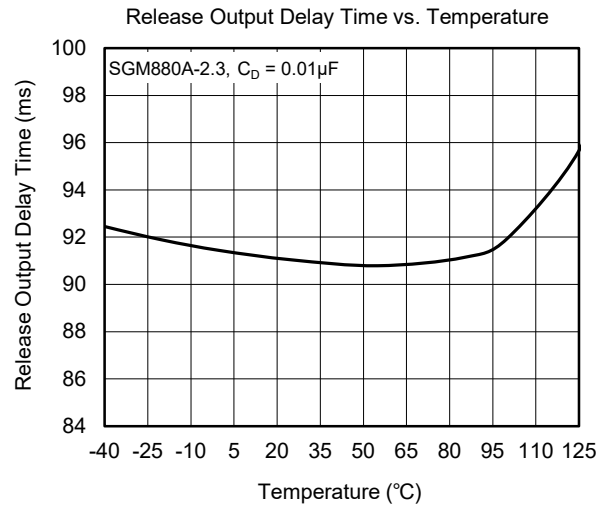
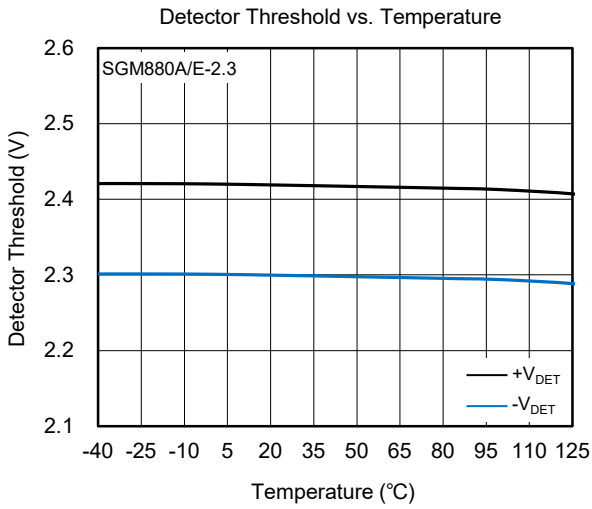

TYPICAL PERFORMANCE CHARACTERISTICS (continued)

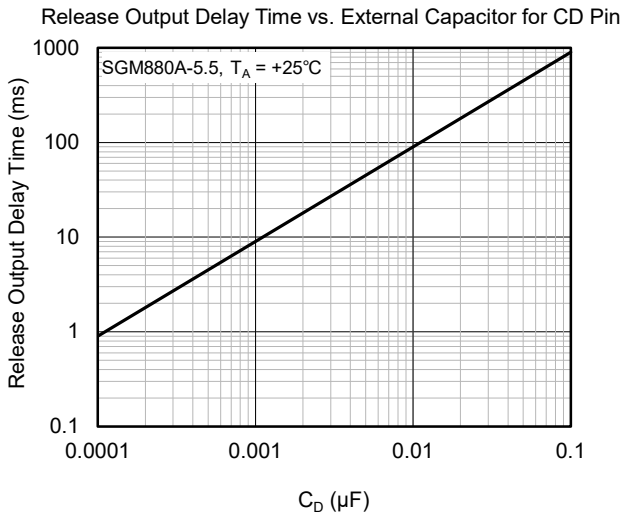

FUNCTIONAL BLOCK DIAGRAMS

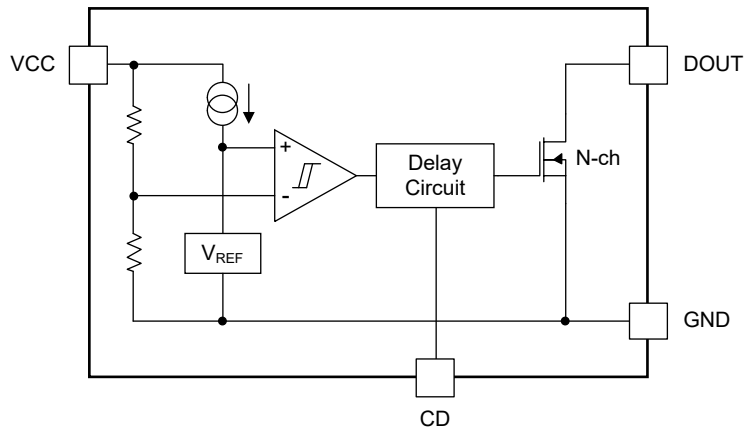

Figure 5. SGM880A Functional Block Diagram

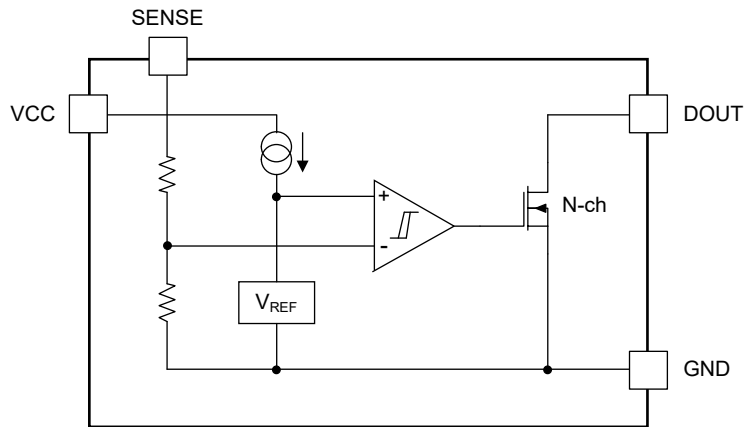

Figure 6. SGM880E Functional Block Diagram

DETAILED DESCRIPTION

Operation Diagram and Description

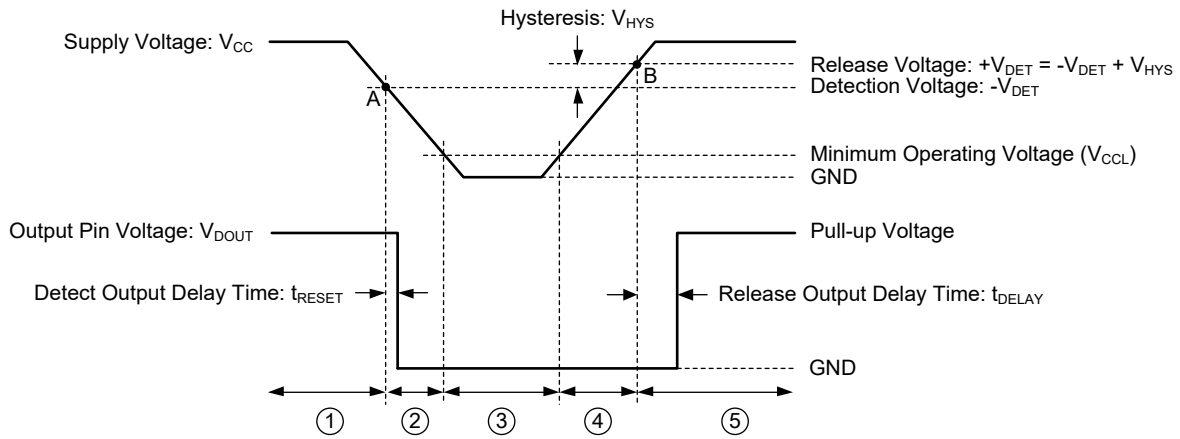

Figure 7. SGM880A Diagram

Table 1. Description of Figure 7

Operating Conditions	Comparator Input Condition	Comparator Output	Output Tr. (N-ch)
①	$V_{CC} > -V_{DET}$	L	Off
②	$V_{CCL} < V_{CC} < -V_{DET}$	H	On
③	$V_{CC} < V_{CCL}$	—	—
④	$V_{CCL} < V_{CC} < +V_{DET}$	H	On
⑤	$V_{CC} > +V_{DET}$	L	Off

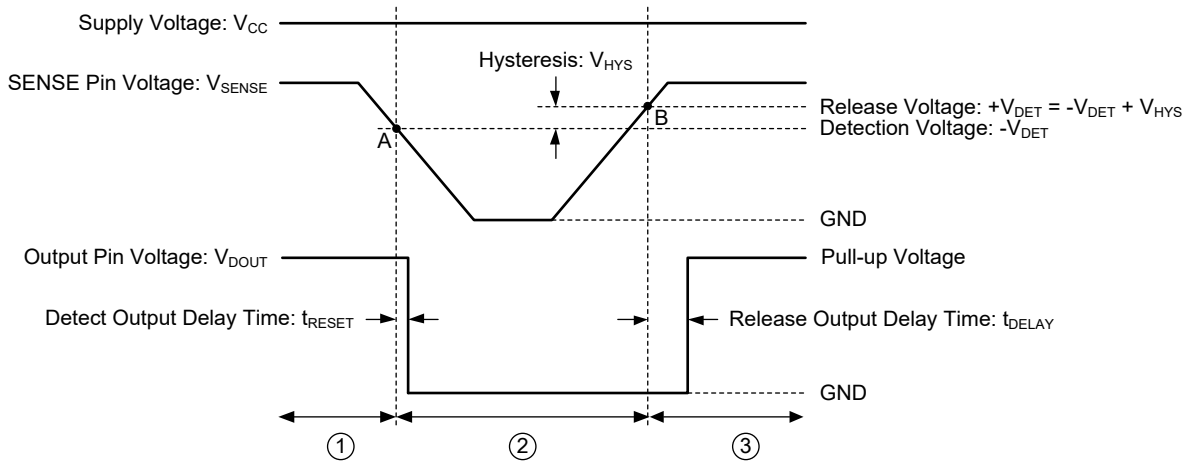

Figure 8. SGM880E Diagram

Table 2. Description of Figure 8

Operating Conditions	Comparator Input Condition	Comparator Output	Output Tr. (N-ch)
①	$V_{SENSE} > -V_{DET}$	L	Off
②	After $V_{SENSE} < -V_{DET}$, $V_{SENSE} < +V_{DET}$	H	On
③	$V_{SENSE} > +V_{DET}$	L	Off

DETAILED DESCRIPTION (continued)

Operating Conditions

SGM880A

- ① DOUT voltage is equal to the voltage rail pulled up to.
- ② At A point, $V_{CC} \leq -V_{DET}$ and DOUT turns low after detected output delay time (t_{RESET}).
- ③ DOUT keeps floating if V_{CC} maintains a value lower than the minimum operating voltage (V_{CCL}).
- ④ DOUT keeps low if V_{CC} does not increase above $+V_{DET}$.
- ⑤ At B point, $V_{CC} > +V_{DET}$ and DOUT turns high after released output delay time (t_{DELAY}). After that, DOUT is equal to the voltage rail pulled up to.

Note that the DOUT pin should be pulled up to an external voltage level, and hysteresis (V_{HYS}) is the voltage difference between $+V_{DET}$ and $-V_{DET}$.

SGM880E

- ① $V_{CC} > V_{UVLO}$ and $V_{SENSE} > +V_{DET}$, DOUT is equal to the voltage rail pulled up to.
- ② At A point, $V_{SENSE} \leq -V_{DET}$ and DOUT turns low after detected output delay time (t_{RESET}).
- ③ At B point, $V_{SENSE} > +V_{DET}$ and DOUT turns high after released output delay time (t_{DELAY}). After that, DOUT is equal to the voltage rail pulled up to.

Note that the DOUT pin should be pulled up to an external voltage level, and hysteresis (V_{HYS}) is the voltage difference between $+V_{DET}$ and $-V_{DET}$.

Power Sequence

The SGM880A monitors the VCC pin voltage and the SGM880E monitors the SENSE pin voltage. Either the VCC pin or the SENSE pin is powered up first is allowed for SGM880.

When the VCC pin voltage of SGM880A or the SENSE pin voltage of SGM880E is larger than the released threshold $+V_{DET}$, the DOUT pin goes high soon. It

should be noted that the SENSE pin voltage can be higher than the VCC pin voltage.

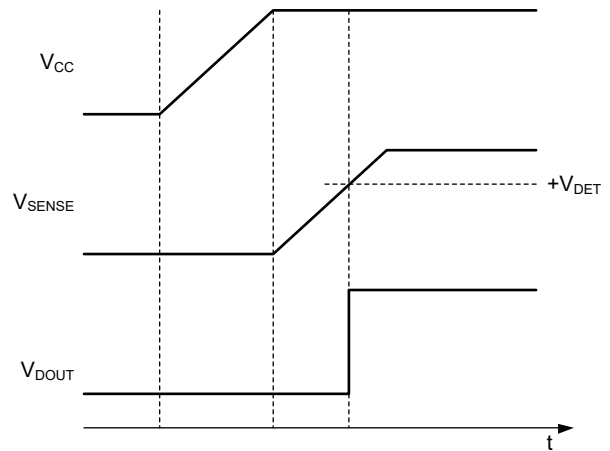

Figure 9. Power-On Timing Diagram

Glitch Detection by VCC, SENSE Pins

Figure 10 and Figure 11 show the relationship between pulse width and overdrive voltage for SGM880A and SGM880E, respectively. The overdrive voltage is defined as how deep the VCC/SENSE pin voltage is below $-V_{DET}$ and the pulse width is defined as the minimum one that a pulse with wider width will result in an active-low DOUT (See Figure 12).

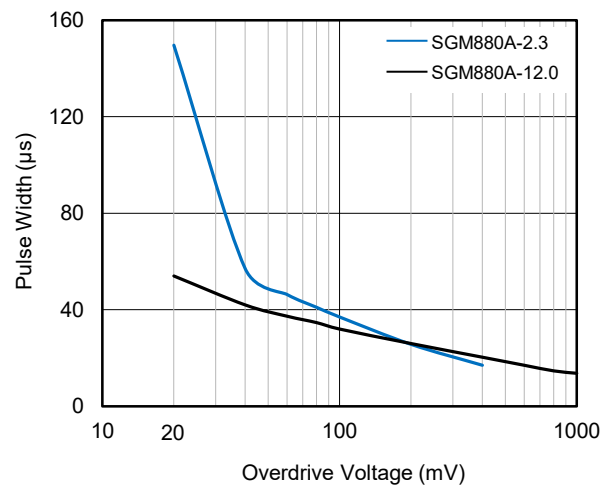

Figure 10. SGM880A Pulse Width vs. Overdrive Voltage

DETAILED DESCRIPTION (continued)

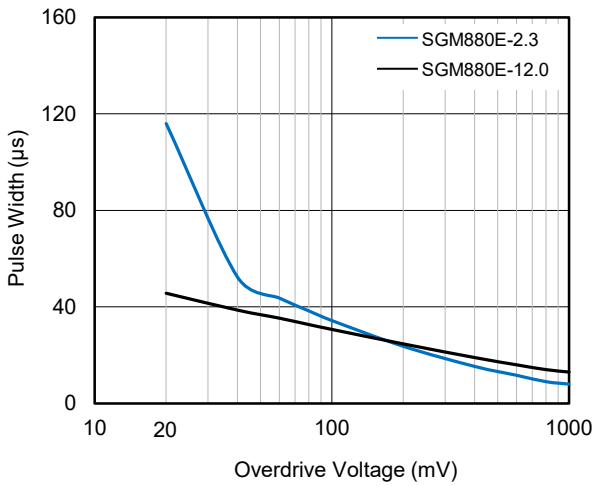

Figure 11. SGM880E Pulse Width vs. Overdrive Voltage

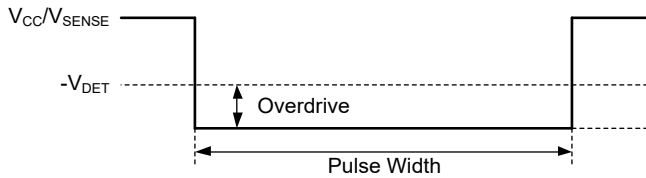

Figure 12. V_{CC}/V_{SENSE} Input Waveform

Timing Chart

When V_{CC} rises above +V_{DET}, the SGM880A begins to charge the capacitor placed at CD pin and the CD pin voltage (V_{CD}) starts to increase. DOUT continues to be low until V_{CD} reaches its threshold voltage (V_{TCD}). After that, DOUT changes from the detected state to released state and the CD capacitor is discharged.

When V_{CC} falls below -V_{DET}, the SGM880A turns from released state to detected state in detect output delay time (t_{RESET}) without any action on the CD pin.

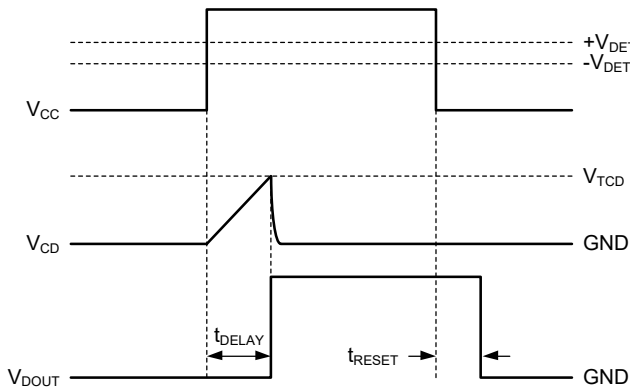

Figure 13. Delay Timing Diagram

Release Output Delay Time (t_{DELAY})

In Figure 14, a pulse shifted from 2.1V to -V_{DET} + 2V is applied on the VCC pin, where the DOUT pin is pulled up to a voltage rail of 5V with a resistor of 100kΩ. The release output delay time (t_{DELAY}) is defined as from the moment V_{CC} changes from 2.1V to -V_{DET} + 2V to the moment DOUT increases to 2.5V.

Hence, t_{DELAY} can be calculated as Equation 1

$$t_{DELAY} (s) = 9.0 \times 10^6 \times C_D (F) \tag{1}$$

where: C_D (F) is the CD pin capacitance.

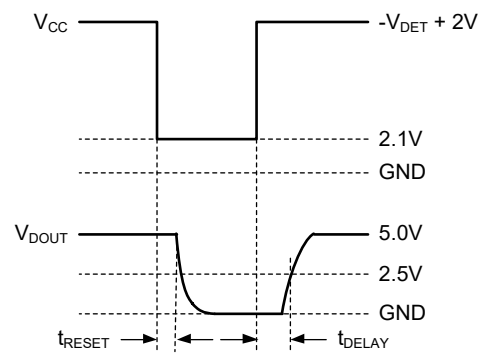

Figure 14. Release Output Delay Time (t_{DELAY})

Connecting Resistors to the Input Pin

Two common application diagrams with a series resistor at the input pin are illustrated in Figure 15 and Figure 16. If a resistor (R₁) is placed between the supply source and the VCC pin of SGM880, the actual VCC pin voltage should be carefully considered. The real difference between the supply source voltage and VCC pin voltage is equal to the product of the VCC pin consumption current (I_{CC}) and resistance of R₁. Note that I_{CC} is much more higher when SGM880 changes from detected state to released state. As a result, the device may go back to detected state again once the VCC pin voltage drops below -V_{DET} due to higher I_{CC}.

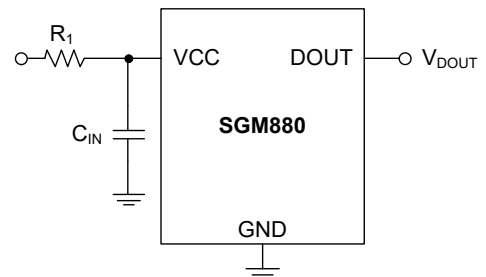

Figure 15. Connecting Series Resistor at VCC Pin

APPLICATION INFORMATION

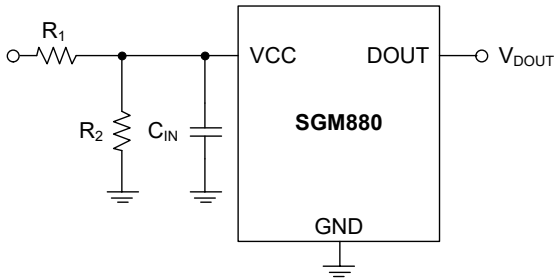

Figure 16. Connecting Resistor Divider at VCC Pin

If the VCC pin voltage slowly rises above the released threshold with large R_1 , V_{DOUT} may ceaselessly be released and detected because of the above process.

It is recommended using $R_1 < 100k\Omega$ and $C_{IN} > 0.1\mu F$. Furthermore, the temperature effect and capacitance DC voltage characteristic should also be considered.

Using Different Input Voltages between SGM880 and CPU

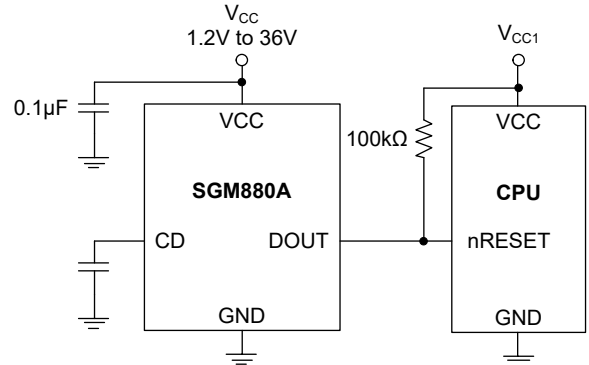

Figure 17. SGM880A Typical Application Circuit

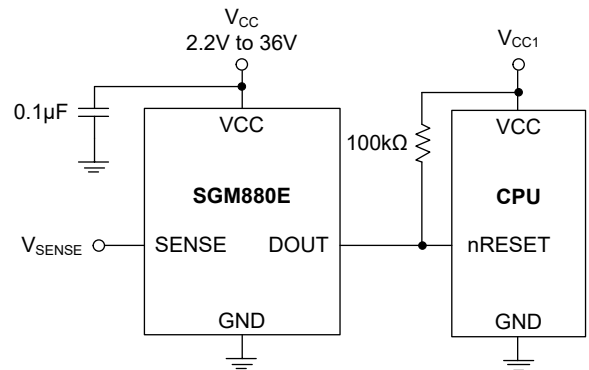

Figure 18. SGM880E Typical Application Circuit

REVISION HISTORY

NOTE: Page numbers for previous revisions may differ from page numbers in the current version.

MARCH 2026 – REV.A to REV.A.1	Page
Updated Package/Ordering Information section.....	2
Changes from Original (NOVEMBER 2024) to REV.A	Page
Changed from product preview to production data.....	All

PACKAGE OUTLINE DIMENSIONS

SOT-23-5

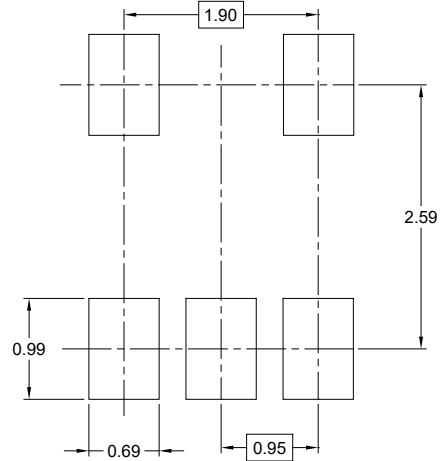
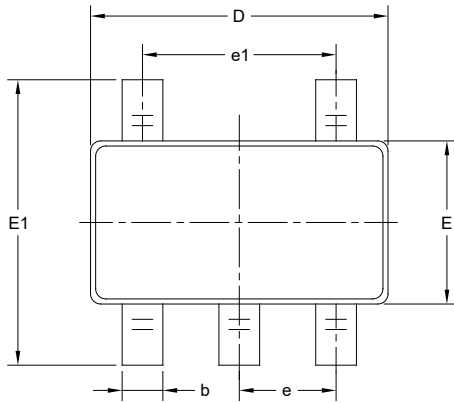

RECOMMENDED LAND PATTERN (Unit: mm)

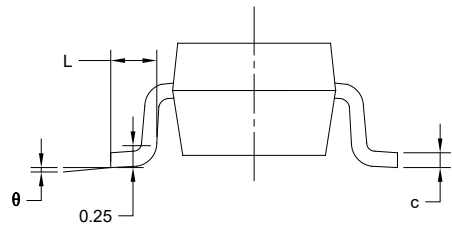
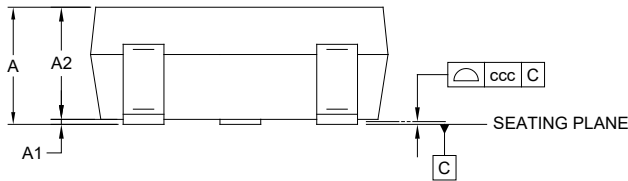

Symbol	Dimensions In Millimeters		
	MIN	NOM	MAX
A	-	-	1.450
A1	0.000	-	0.150
A2	0.900	-	1.300
b	0.300	-	0.500
c	0.080	-	0.220
D	2.750	-	3.050
E	1.450	-	1.750
E1	2.600	-	3.000
e	0.950 BSC		
e1	1.900 BSC		
L	0.300	-	0.600
θ	0°	-	8°
ccc	0.100		

NOTES:

1. This drawing is subject to change without notice.
2. The dimensions do not include mold flashes, protrusions or gate burrs.
3. Reference JEDEC MO-178.

PACKAGE INFORMATION

TAPE AND REEL INFORMATION

REEL DIMENSIONS

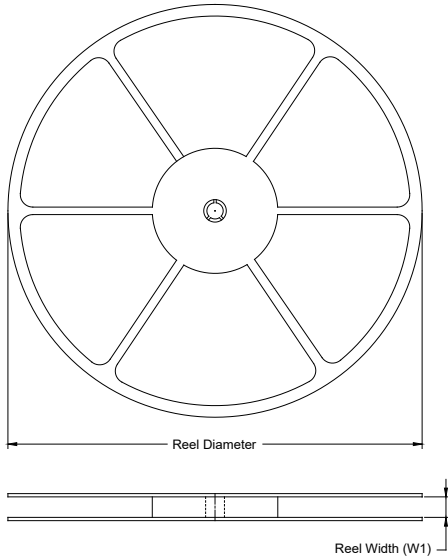

TAPE DIMENSIONS

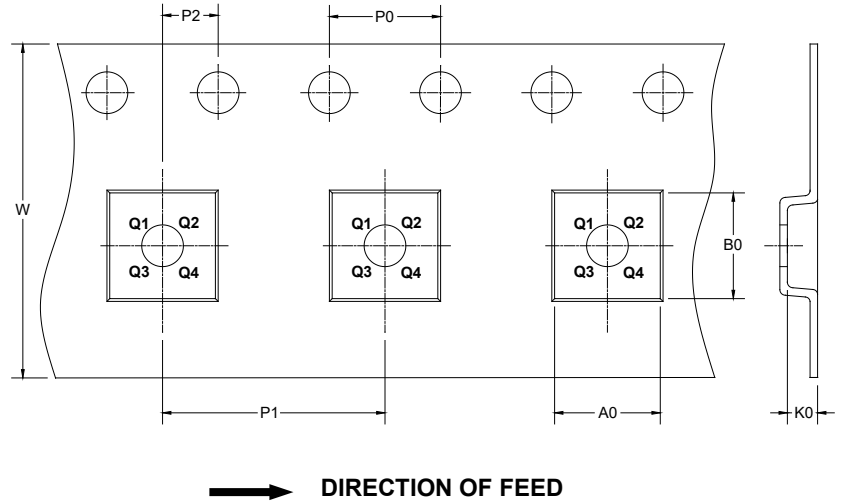

NOTE: The picture is only for reference. Please make the object as the standard.

KEY PARAMETER LIST OF TAPE AND REEL

Package Type	Reel Diameter	Reel Width W1 (mm)	A0 (mm)	B0 (mm)	K0 (mm)	P0 (mm)	P1 (mm)	P2 (mm)	W (mm)	Pin1 Quadrant
SOT-23-5	7"	9.5	3.20	3.20	1.40	4.0	4.0	2.0	8.0	Q3

DD0001

PACKAGE INFORMATION

CARTON BOX DIMENSIONS

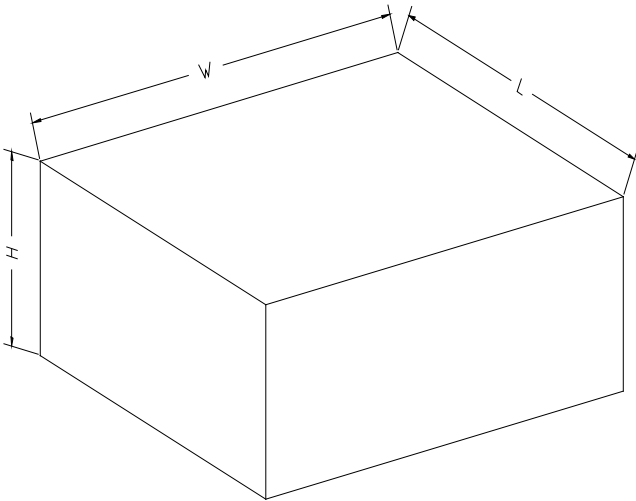

NOTE: The picture is only for reference. Please make the object as the standard.

KEY PARAMETER LIST OF CARTON BOX

Reel Type	Length (mm)	Width (mm)	Height (mm)	Pizza/Carton
7" (Option)	368	227	224	8
7"	442	410	224	18

D00002