

### FEATURES

- Low On-State Resistance
- Low QG and Capacitance Losses
- RoHS Compliant and Halogen Free

### ABSOLUTE MAXIMUM RATINGS

PARAMETER	SYMBOL	VALUE	UNITS
Drain-to-Source Voltage	$V_{DS}$	60	V
Gate-to-Source Voltage	$V_{GS}$	$\pm 20$	V
Drain Current <sup>(1)</sup>	$I_D$	$T_C = +25^\circ\text{C}$	65
		$T_C = +100^\circ\text{C}$	65
		$T_A = +25^\circ\text{C}$	21
		$T_A = +70^\circ\text{C}$	16
Drain Current (Pulse) <sup>(2)</sup>	$I_{DM}$	745	A
Total Dissipation	$P_D$	$T_C = +25^\circ\text{C}$	109
		$T_C = +100^\circ\text{C}$	43
		$T_A = +25^\circ\text{C}$	2.5
		$T_A = +70^\circ\text{C}$	1.6
Avalanche Current	$I_{AS}$	85	A
Avalanche Energy	$E_{AS}$	361.2	mJ
Junction Temperature	$T_J$	+150	$^\circ\text{C}$
Storage Temperature Range	$T_{STG}$	-55 to +150	$^\circ\text{C}$
Lead Temperature (Soldering, 10s)		+260	$^\circ\text{C}$

Stresses beyond those listed in Absolute Maximum Ratings may cause permanent damage to the device. Exposure to absolute maximum rating conditions for extended periods may affect reliability.

**NOTES:**

1. The current will be limited by package, PCB, thermal design and operating temperature. Bonding wire limitation current is 65A; with an  $R_{\theta JC} = 1.1^\circ\text{C/W}$  the chip is able to carry 125A at  $25^\circ\text{C}$ .
2.  $t_{PLUSE} < 10\mu\text{s}$ .
3. Parts are 100% tested at  $V_{GS} = 10\text{V}$ ,  $I_L = 60\text{A}$ , and  $E_{AS} = 180.6\text{mJ}$ .

### PRODUCT SUMMARY

$R_{DS(ON)}$ (TYP) $V_{GS} = 10\text{V}$	$R_{DS(ON)}$ (MAX) $V_{GS} = 10\text{V}$	$I_D$ (MAX) $T_C = +25^\circ\text{C}$
2.5m $\Omega$	3.1m $\Omega$	65A

### PIN CONFIGURATION

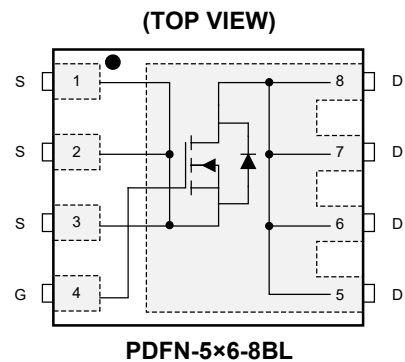

### EQUIVALENT CIRCUIT

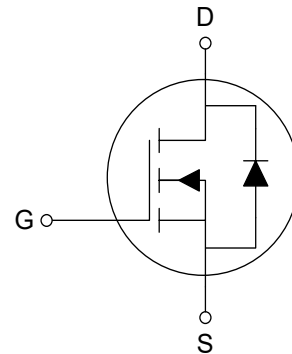

### APPLICATIONS

- 12/24V Automotive Systems
- Multimedia/Infotainment Bus Protection
- Transmission Control
- Ultra-High Performance Power Switching
- Automotive Systems LED Lighting

**PACKAGE/ORDERING INFORMATION**

MODEL	PACKAGE DESCRIPTION	SPECIFIED TEMPERATURE RANGE	ORDERING NUMBER	PACKAGE MARKING	PACKING OPTION
SGMNQ35460	PDFN-5x6-8BL	-55°C to +150°C	SGMNQ35460TPDA8G/TR	SGM108 TPDA8 XXXXX	Tape and Reel, 4000

**MARKING INFORMATION**

NOTE: XXXXX = Date Code, Trace Code and Vendor Code.

**XXXXX**

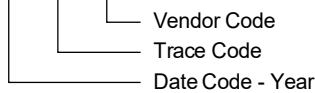

Green (RoHS & HSF): SG Micro Corp defines "Green" to mean Pb-Free (RoHS compatible) and free of halogen substances. If you have additional comments or questions, please contact your SGMICRO representative directly.

**DISCLAIMER**

SG Micro Corp reserves the right to make any change in circuit design, or specifications without prior notice.

**THERMAL RESISTANCE**

PARAMETER	SYMBOL	TYP	UNITS
Junction-to-Case Thermal Resistance	$R_{\theta JC}$	1.1	°C/W
Junction-to-Ambient Thermal Resistance <sup>(1)</sup>	$R_{\theta JA}$	50	°C/W

NOTE: 1.  $R_{\theta JA}$  is determined with the device mounted on one square inch of copper pad, 2oz copper on FR4 board.

**ELECTRICAL CHARACTERISTICS**(T<sub>A</sub> = +25°C, unless otherwise noted.)

PARAMETER	SYMBOL	CONDITIONS	MIN	TYP	MAX	UNITS
<b>Static OFF Characteristics</b>						
Drain-to-Source Breakdown Voltage	V <sub>BR_DSS</sub>	V <sub>GS</sub> = 0V, I <sub>D</sub> = 250μA	60			V
Zero Gate Voltage Drain Current	I <sub>DSS</sub>	V <sub>GS</sub> = 0V, V <sub>DS</sub> = 48V			1	μA
Gate-to-Source Leakage Current	I <sub>GSS</sub>	V <sub>GS</sub> = ±20V, V <sub>DS</sub> = 0V			±100	nA
<b>Static ON Characteristics</b>						
Gate-to-Source Threshold Voltage	V <sub>GS_TH</sub>	V <sub>GS</sub> = V <sub>DS</sub> , I <sub>D</sub> = 250μA	1.2	1.75	2.5	V
Drain-to-Source On-State Resistance	R <sub>DS(on)</sub>	I <sub>D</sub> = 30A	V <sub>GS</sub> = 10V	2.5	3.1	mΩ
			V <sub>GS</sub> = 4.5V	3.5	4.6	
Forward Transconductance	g <sub>FS</sub>	V <sub>DS</sub> = 5V, I <sub>D</sub> = 30A		65		S
Gate Resistance	R <sub>G</sub>	V <sub>GS</sub> = 0V, V <sub>DS</sub> = 0V, f = 1MHz		1		Ω
<b>Diode Characteristics</b>						
Diode Forward Voltage	V <sub>F_SD</sub>	V <sub>GS</sub> = 0V, I <sub>S</sub> = 30A		0.8	1.2	V
Reverse Recovery Time	t <sub>RR</sub>	V <sub>GS</sub> = 0V, I <sub>S</sub> = 30A, di/dt = 100A/μs		109		ns
Reverse Recovery Charge	Q <sub>RR</sub>			112		nC
<b>Dynamic Characteristics</b>						
Input Capacitance	C <sub>ISS</sub>	V <sub>GS</sub> = 0V, V <sub>DS</sub> = 30V, f = 1MHz		4733		pF
Output Capacitance	C <sub>OSS</sub>			1092		
Reverse Transfer Capacitance	C <sub>RSS</sub>			89		
Total Gate Charge	Q <sub>G</sub>	V <sub>DS</sub> = 30V, I <sub>D</sub> = 30A	V <sub>GS</sub> = 10V	99		nC
			V <sub>GS</sub> = 4.5V	50		
Gate-to-Source Charge	Q <sub>GS</sub>	V <sub>GS</sub> = 4.5V, V <sub>DS</sub> = 30V, I <sub>D</sub> = 30A		16		nC
Gate-to-Drain Charge	Q <sub>GD</sub>			24		
<b>Switch Characteristics</b>						
Turn-On Delay Time	t <sub>D_ON</sub>	V <sub>GS</sub> = 10V, V <sub>DS</sub> = 30V, I <sub>D</sub> = 30A, R <sub>G</sub> = 3Ω		12		ns
Rise Time	t <sub>r</sub>			39		
Turn-Off Delay Time	t <sub>D_OFF</sub>			60		
Fall Time	t <sub>f</sub>			65		

TYPICAL PERFORMANCE CHARACTERISTICS

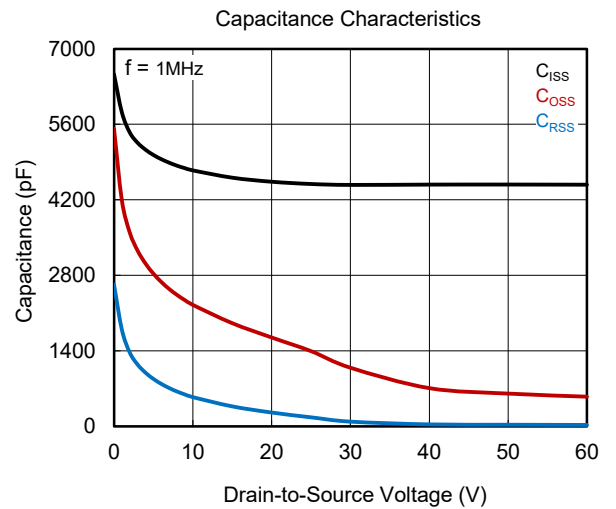
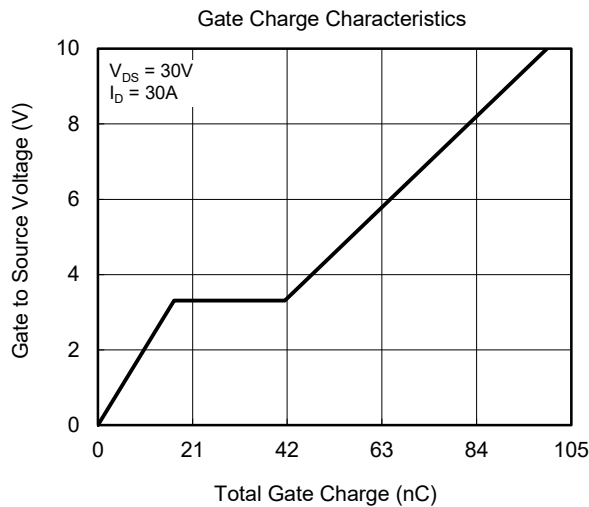
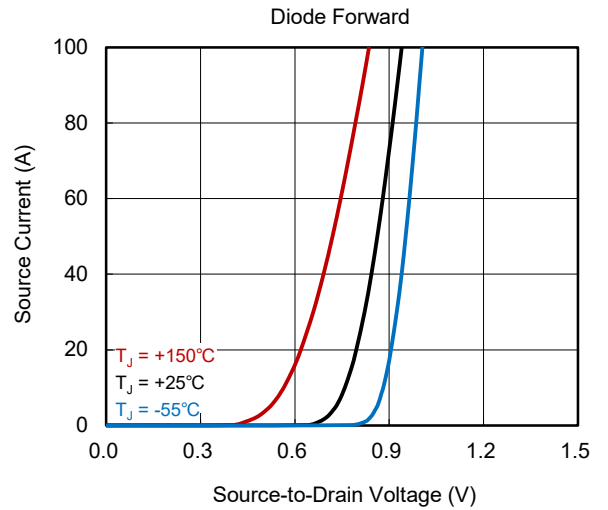
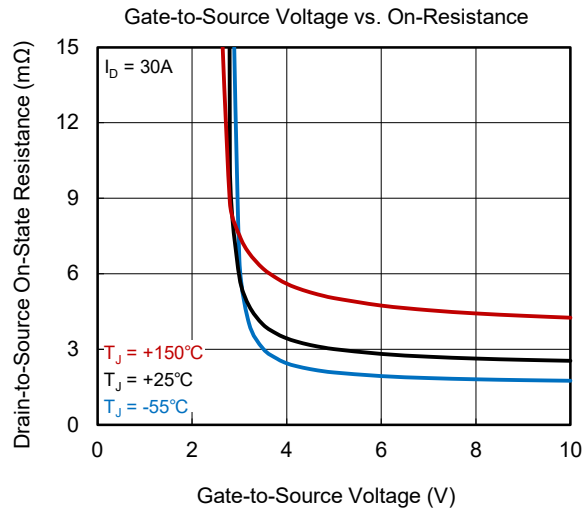
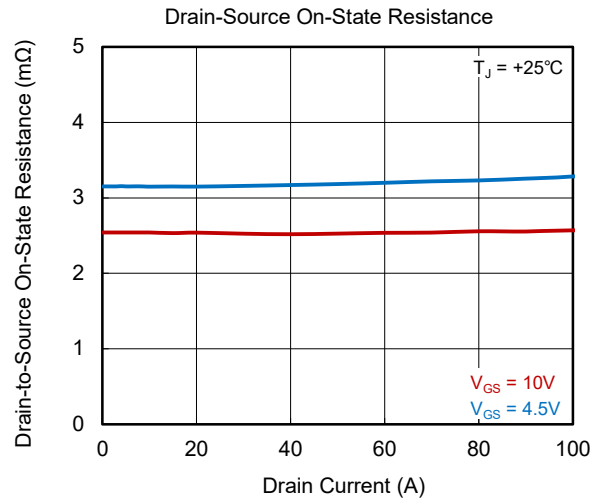
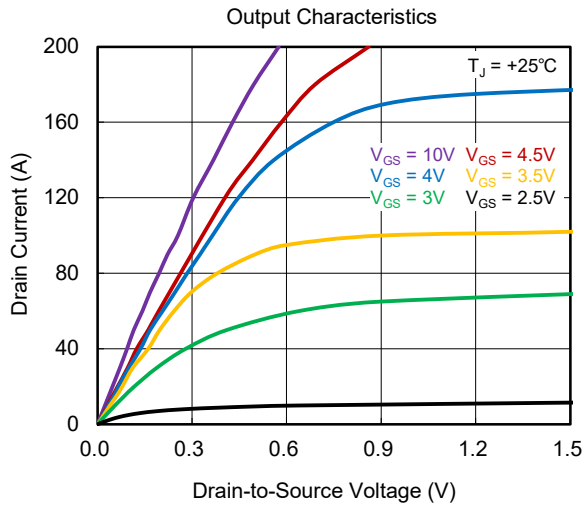

TYPICAL PERFORMANCE CHARACTERISTICS (continued)

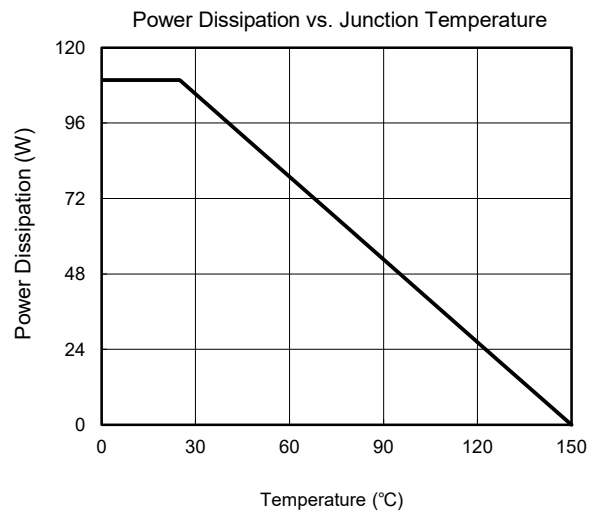
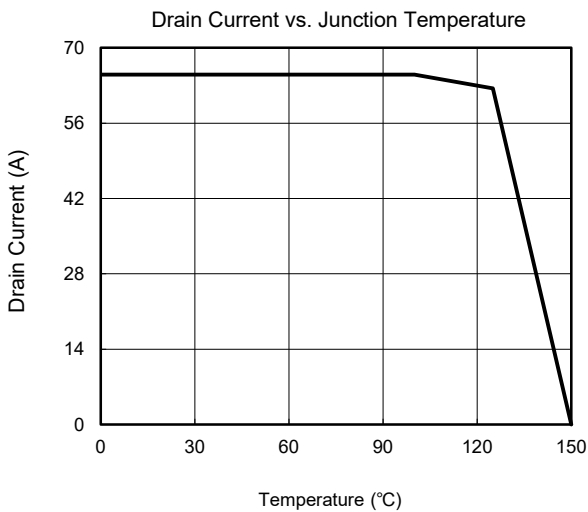
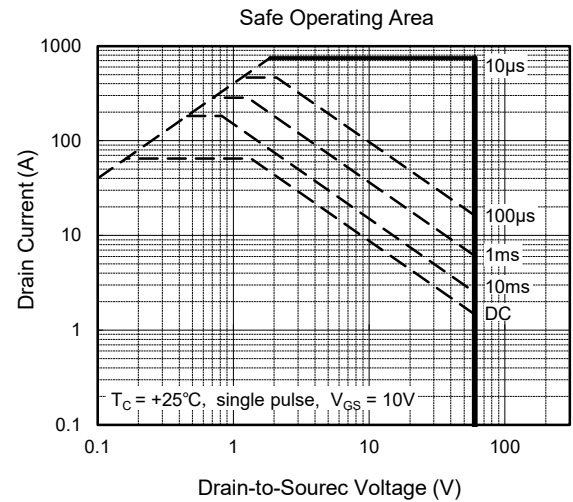
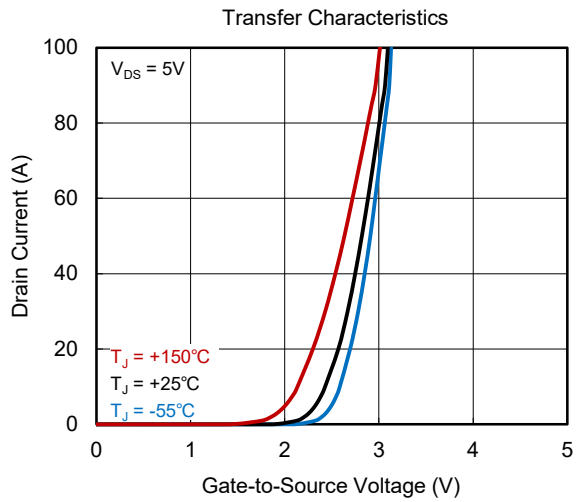
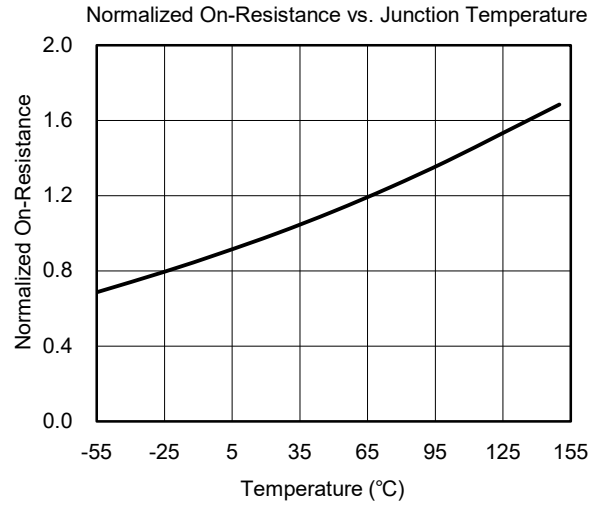
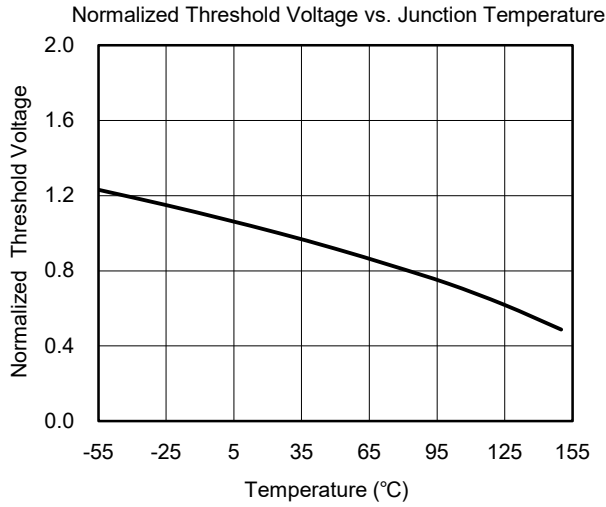

TYPICAL PERFORMANCE CHARACTERISTICS (continued)

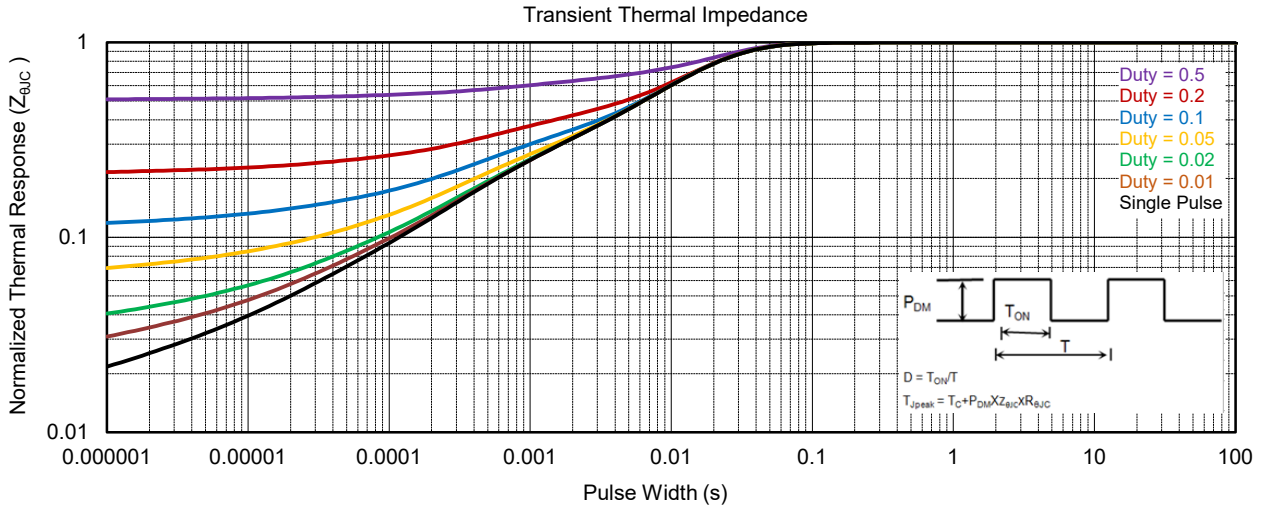

REVISION HISTORY

NOTE: Page numbers for previous revisions may differ from page numbers in the current version.

DECEMBER 2025 – REV.A to REV.A.1	Page
Updated absolute maximum ratings.....	1
Changes from Original to REV.A (SEPTEMBER 2025)	Page
Changed from product preview to production data.....	All

# PACKAGE INFORMATION

## PACKAGE OUTLINE DIMENSIONS

### PDFN-5×6-8BL

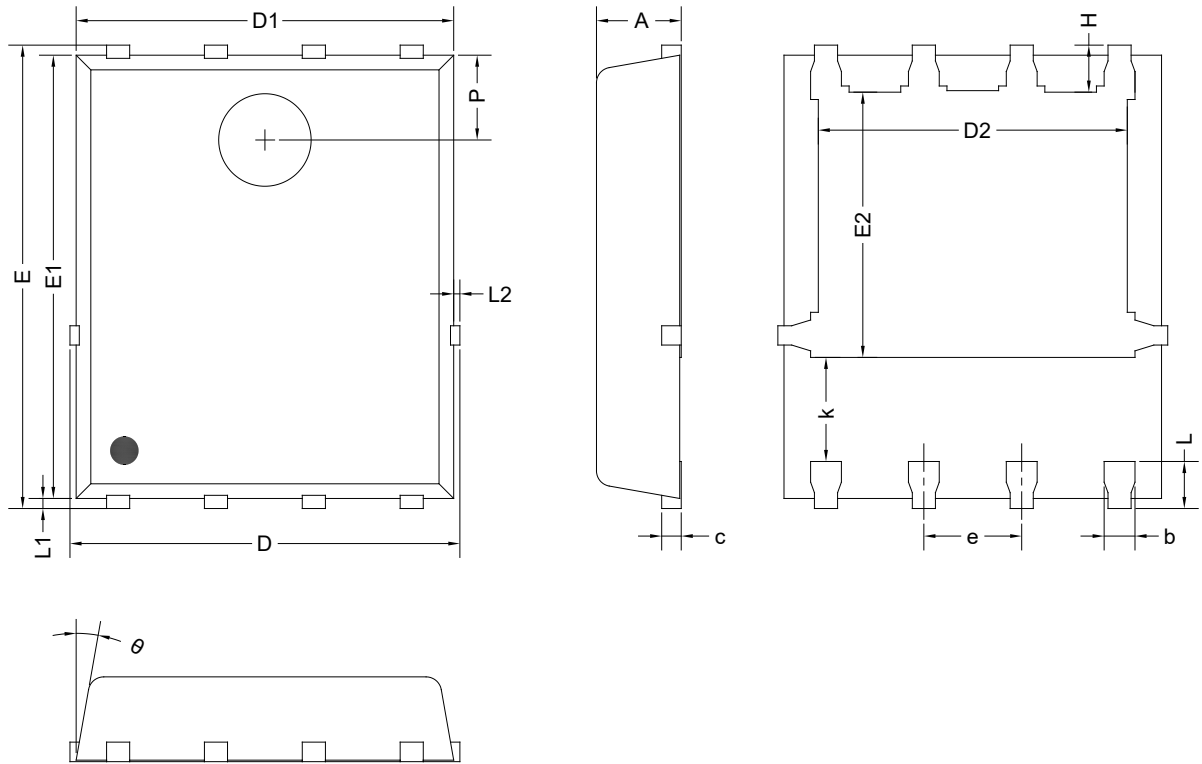

Symbol	Dimensions In Millimeters		
	MIN	NOM	MAX
A	1.000	1.100	1.200
b	0.350	0.400	0.450
c	0.210	0.250	0.340
D	4.800	-	5.100
D1	4.800	4.900	5.000
D2	3.910	4.010	4.110
E	5.900	6.000	6.100
E1	5.700	5.750	5.800
E2	3.340	3.440	3.540
e	1.270 BSC		
H	0.510	0.610	0.710
k	1.100	-	-
L	0.510	0.610	0.710
L1	0.060	0.130	0.200
L2	-	-	0.100
P	1.000	1.100	1.200
θ	8°	10°	12°

NOTE: This drawing is subject to change without notice.

# PACKAGE INFORMATION

## TAPE AND REEL INFORMATION

### REEL DIMENSIONS

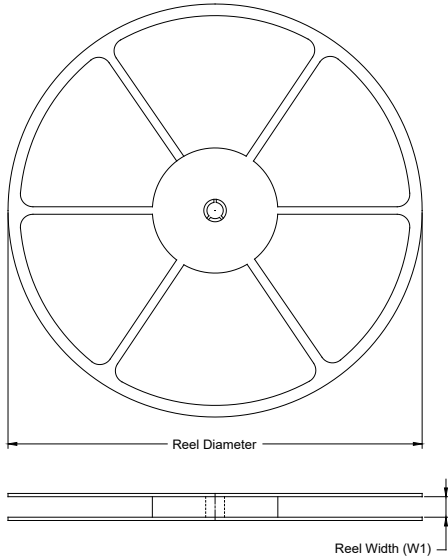

### TAPE DIMENSIONS

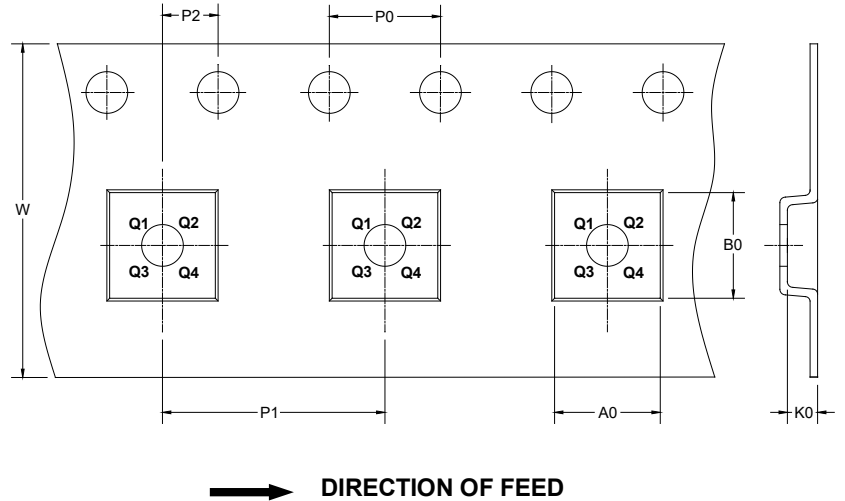

NOTE: The picture is only for reference. Please make the object as the standard.

### KEY PARAMETER LIST OF TAPE AND REEL

Package Type	Reel Diameter	Reel Width W1 (mm)	A0 (mm)	B0 (mm)	K0 (mm)	P0 (mm)	P1 (mm)	P2 (mm)	W (mm)	Pin1 Quadrant
PDFN-5×6-8BL	13"	12.4	6.45	5.30	1.40	4.0	8.0	2.0	12.0	Q1

DD0001

# PACKAGE INFORMATION

## CARTON BOX DIMENSIONS

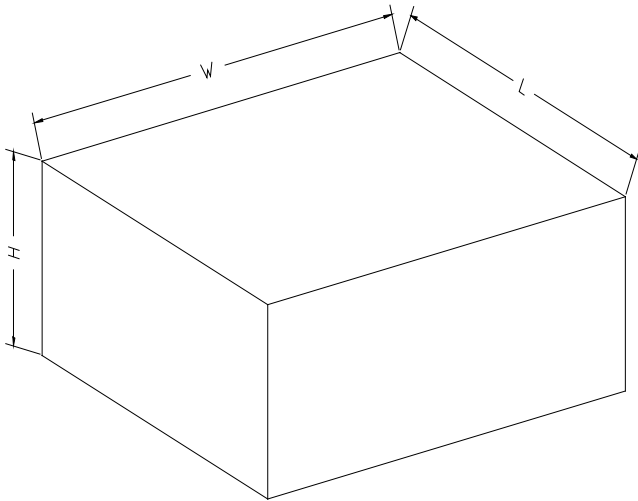

NOTE: The picture is only for reference. Please make the object as the standard.

## KEY PARAMETER LIST OF CARTON BOX

Reel Type	Length (mm)	Width (mm)	Height (mm)	Pizza/Carton
13"	386	280	370	5

DD0002