



# SGM25007A

## 5.5V, 7A Low $R_{DS(ON)}$ Load Switch with Programmable Current Limit, Power Good, and Output Discharge Function

### GENERAL DESCRIPTION

The SGM25007A is an N-MOSFET power switch with 7A load protection function. The switch operates from a wide range of 0.5V to 5.5V supply voltage. The small package and low  $R_{DS(ON)}$  make the device very suitable for space limited, and battery powered applications, such as notebook, tablet computer or other portable devices.

The SGM25007A integrates programmable current limit to protect the upstream power supply from damage during over-current or short-circuit condition. An integrated soft-start function is designed to avoid inrush current during startup stage.

A number of protection features are provided in the device including programmable soft-start time, over-current protection and over-temperature shutdown. The device also provides the quick output discharge function in disable status.

The SGM25007A is available in a Green TQFN-2×2-12CL package.

### FEATURES

- Input Voltage Range: 0.5V to 5.5V
- On-Resistance: 6.3m $\Omega$  (TYP)
- Shutdown Current: 1.5 $\mu$ A (MAX)
- Load Current Limit: 7A (TYP)
- High Output Current Monitoring Accurate
- Built-in PG Indicator
- Built-in Soft-Start Function
- Built-in Output Discharge Function
- Fast Short-Circuit Response: < 200ns
- Thermal Shutdown Protection
- Available in a Green TQFN-2×2-12CL Package

### APPLICATIONS

Notebook  
Tablet PC  
Portable Devices  
Solid State Drivers  
Handheld Devices

### TYPICAL APPLICATION

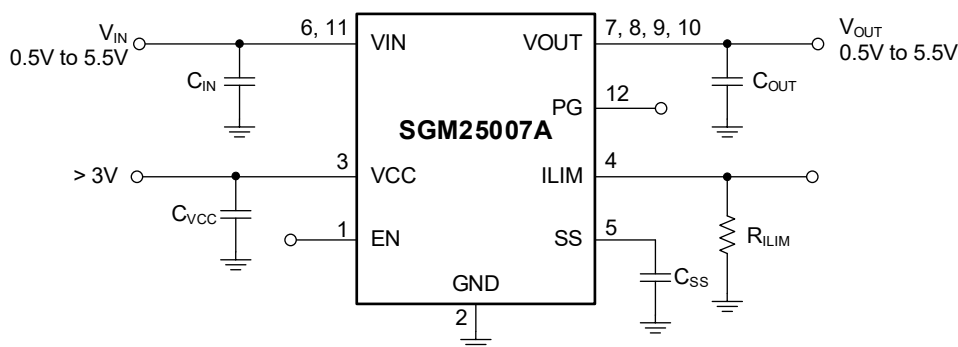

Figure 1. Typical Application Circuit

# 5.5V, 7A Low $R_{DS(ON)}$ Load Switch with Programmable Current Limit, Power Good, and Output Discharge Function

## SGM25007A

### PACKAGE/ORDERING INFORMATION

MODEL	PACKAGE DESCRIPTION	SPECIFIED TEMPERATURE RANGE	ORDERING NUMBER	PACKAGE MARKING	PACKING OPTION
SGM25007A	TQFN-2x2-12CL	-40°C to +125°C	SGM25007AXTVS12G/TR	15R XXXX	Tape and Reel, 5000

### MARKING INFORMATION

NOTE: XXXXX = Date Code, Trace Code and Vendor Code.

**XXXX**

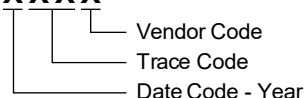

Green (RoHS & HSF): SG Micro Corp defines "Green" to mean Pb-Free (RoHS compatible) and free of halogen substances. If you have additional comments or questions, please contact your SGMICRO representative directly.

### ABSOLUTE MAXIMUM RATINGS

$V_{IN}$ .....	-0.3V to 6.5V
$V_{CC}$ .....	-0.3V to 6.5V
$V_{OUT}$ .....	-0.3V to 6.5V
EN, SS, ILIM.....	-0.3V to 6.5V
Package Thermal Resistance	
TQFN-2x2-12CL, $\theta_{JA}$ .....	75°C/W
TQFN-2x2-12CL, $\theta_{JB}$ .....	11.2°C/W
TQFN-2x2-12CL, $\theta_{JC}$ .....	64.3°C/W
Junction Temperature.....	+150°C
Storage Temperature Range.....	-65°C to +150°C
Lead Temperature (Soldering, 10s).....	+260°C
ESD Susceptibility <sup>(1) (2)</sup>	
HBM.....	±4000V
CDM.....	±1000V

NOTES:

- For human body model (HBM), all pins comply with ANSI/ESDA/JEDEC JS-001 specifications.
- For charged device model (CDM), all pins comply with ANSI/ESDA/JEDEC JS-002 specifications.

### RECOMMENDED OPERATING CONDITIONS

$V_{IN}$ .....	0.5V to 5.5V
$V_{CC}$ .....	3V to 5.5V
All Other Pins.....	0V to 5.5V
Operating Junction Temperature Range.....	-40°C to +125°C

### OVERSTRESS CAUTION

Stresses beyond those listed in Absolute Maximum Ratings may cause permanent damage to the device. Exposure to absolute maximum rating conditions for extended periods may affect reliability. Functional operation of the device at any conditions beyond those indicated in the Recommended Operating Conditions section is not implied.

### ESD SENSITIVITY CAUTION

This integrated circuit can be damaged if ESD protections are not considered carefully. SGMICRO recommends that all integrated circuits be handled with appropriate precautions. Failure to observe proper handling and installation procedures can cause damage. ESD damage can range from subtle performance degradation to complete device failure. Precision integrated circuits may be more susceptible to damage because even small parametric changes could cause the device not to meet the published specifications.

### DISCLAIMER

SG Micro Corp reserves the right to make any change in circuit design, or specifications without prior notice.

# 5.5V, 7A Low $R_{DS(ON)}$ Load Switch with Programmable Current Limit, Power Good, and Output Discharge Function

## SGM25007A

### PIN CONFIGURATION

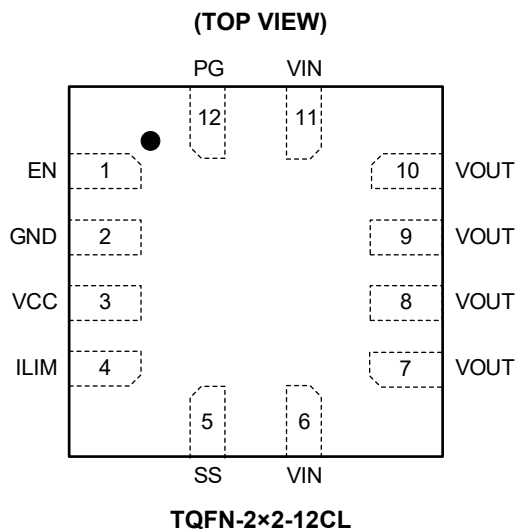

### PIN DESCRIPTION

PIN	NAME	FUNCTION
1	EN	Enable Input. Logic high to enable the device.
2	GND	GND.
3	VCC	Supply Voltage to Controller.
4	ILIM	Current Limit Programming Pin. Connect a resistor $R_{ILIM}$ from this pin to GND to set the overload current limit threshold.
5	SS	Soft-Start Time Program Pin. The capacitor between SS and GND pins will set the slew rate according to the application requirements.
6, 11	VIN	Switch Input.
7, 8, 9, 10	VOUT	Switch Output.
12	PG	Power Good Indicator Pin.

# 5.5V, 7A Low $R_{DS(ON)}$ Load Switch with Programmable Current Limit, SGM25007A Power Good, and Output Discharge Function

## ELECTRICAL CHARACTERISTICS

( $V_{IN} = 3.6V$ ,  $V_{CC} = 3.6V$ ,  $T_J = -40^{\circ}C$  to  $+125^{\circ}C$ , typical values are measured at  $T_J = +25^{\circ}C$ , unless otherwise noted.)

PARAMETER	SYMBOL	CONDITIONS	MIN	TYP	MAX	UNITS		
<b>Input and Supply Voltage (VIN, VCC)</b>								
Input Voltage	$V_{IN}$		0.5		5.5	V		
Supply Voltage	$V_{CC}$		3		5.5	V		
Off-State Leakage Current	$I_{OFF}$	$V_{IN} = 5V$ , $V_{EN} = \text{low}$ , $T_J = +25^{\circ}C$			1	$\mu A$		
$V_{CC}$ Standby Current	$I_{STBY}$	$V_{CC} = 5V$ , $V_{EN} = \text{low}$		0.2	1.5	$\mu A$		
		$V_{CC} = 5V$ , enable, no load		172	260			
<b>Power FET (VIN - VOUT)</b>								
On-Resistance	$R_{DS(ON)}$	$V_{CC} = 5V$		6.3	13	m $\Omega$		
		$V_{CC} = 3.3V$		6.4	13			
<b>Under-Voltage Protection</b>								
$V_{CC}$ Under-Voltage Lockout Threshold	$V_{CC\_UVLO}$	Rising		2.6	2.7	V		
UVLO Hysteresis	$V_{UVLO\_HYS}$			185		mV		
<b>Soft-Start (SS)</b>								
SS Pull-Up Current	$I_{SS}$	Fixed slew rate		9		$\mu A$		
<b>Enable (EN)</b>								
EN Threshold	$V_{ENH}$	Rising	1.43	1.56	1.68	V		
EN Hysteresis	$V_{EN\_HYS}$			400		mV		
<b>ILIM</b>								
Current Limit	$I_{OUT}$	$R_{ILIM} = 50k\Omega$ , ramp $I_{OUT}$ record peak current limit	$T_J = +25^{\circ}C$	1.53	1.65	1.77	A	
			$T_J = -40^{\circ}C$ to $+125^{\circ}C$	1.49	1.65	1.81		
Current Monitor Accuracy	$I_{MON}$		$V_{IN} = 3.6V$ , $T_J = +25^{\circ}C$	$I_{OUT} = 3.75A$	42.36	44.58	46.81	$\mu A$
				$I_{OUT} = 3A$	34.20	35.81	37.42	
				$I_{OUT} = 1.5A$	17.38	18.28	19.20	
				$I_{OUT} = 3.75A$	41.01	44.58	48.16	
				$I_{OUT} = 3A$	32.94	35.81	38.68	
				$I_{OUT} = 1.5A$	16.82	18.28	19.75	
			$V_{IN} = 1.2V$ , $T_J = +25^{\circ}C$	$I_{OUT} = 3.75A$	42.38	45.09	47.79	
				$I_{OUT} = 3A$	33.99	36.2	38.33	
				$I_{OUT} = 1.5A$	17.24	18.35	19.45	
				$I_{OUT} = 3.75A$	41.02	45.09	49.15	
				$I_{OUT} = 3A$	32.9	36.2	39.42	
				$I_{OUT} = 1.5A$	16.69	18.35	20.00	
<b>Discharge Resistance</b>								
Discharge Resistance	$R_{DIS}$			200		$\Omega$		
<b>Power Good (PG) Indication</b>								
VIN Power Good Threshold	$V_{PG\_R}$		2.82	2.927	3.04	V		
VIN Power Good Hysteresis	$V_{PG\_HYS}$			100		mV		
Power Good Rising Delay Time	$t_{PG\_D\_R}$			100		$\mu s$		
Power Good Deglitch Delay Time	$t_{PG\_DEG}$				5	$\mu s$		
Power Good High	$V_{PG\_H}$	$V_{CC} = 3.3V$	3.2			V		
Power Good Low	$V_{PG\_L}$	Sink 1mA			0.2	V		
<b>Thermal Shutdown and Recovery</b>								
Thermal Shutdown Rising Threshold	$T_{SD}$			150		$^{\circ}C$		
Thermal Shutdown Hysteresis	$T_{HYS}$			20		$^{\circ}C$		

# 5.5V, 7A Low $R_{DS(ON)}$ Load Switch with Programmable Current Limit, Power Good, and Output Discharge Function

## SGM25007A

### TYPICAL PERFORMANCE CHARACTERISTICS

$T_J = +25^\circ\text{C}$ , unless otherwise noted.

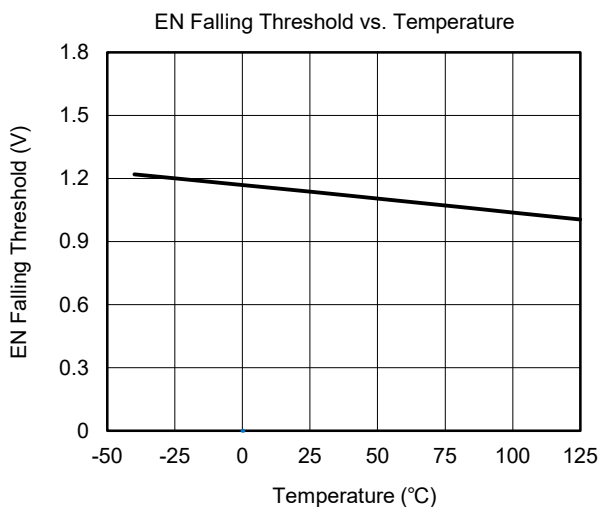
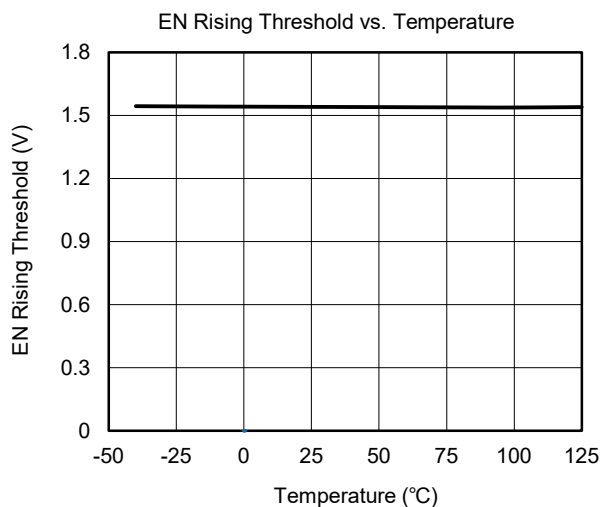
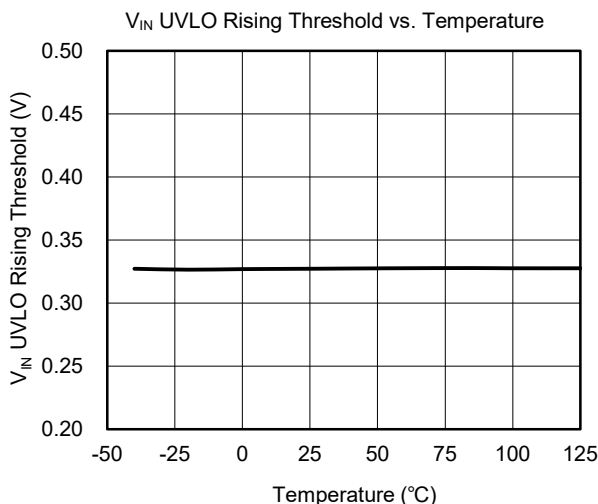
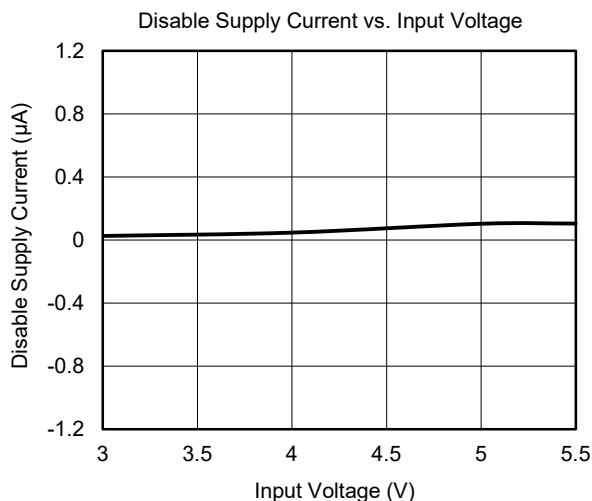
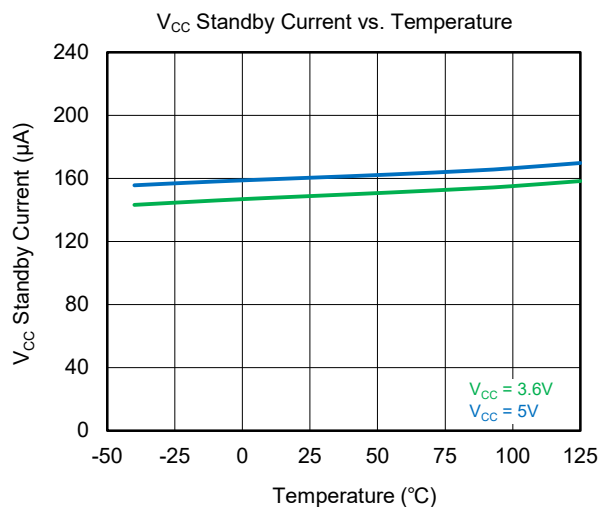
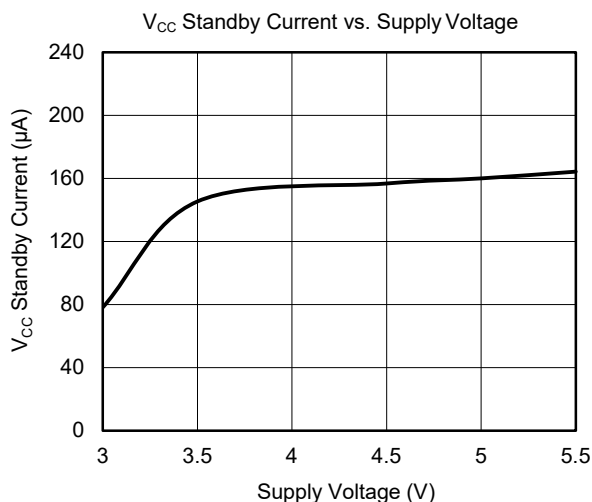

# 5.5V, 7A Low $R_{DS(ON)}$ Load Switch with Programmable Current Limit, Power Good, and Output Discharge Function

## SGM25007A

### TYPICAL PERFORMANCE CHARACTERISTICS (continued)

$T_J = +25^\circ\text{C}$ , unless otherwise noted.

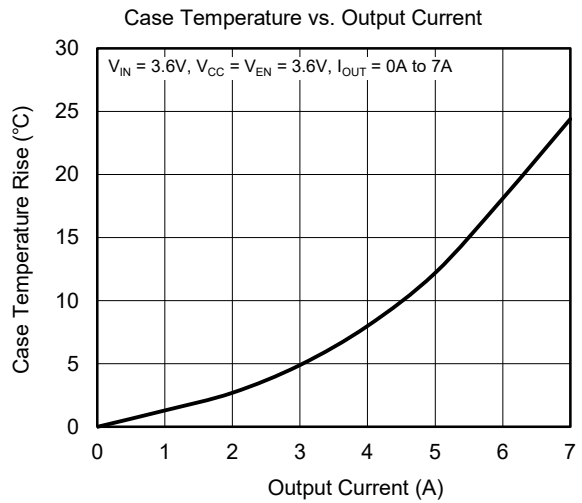
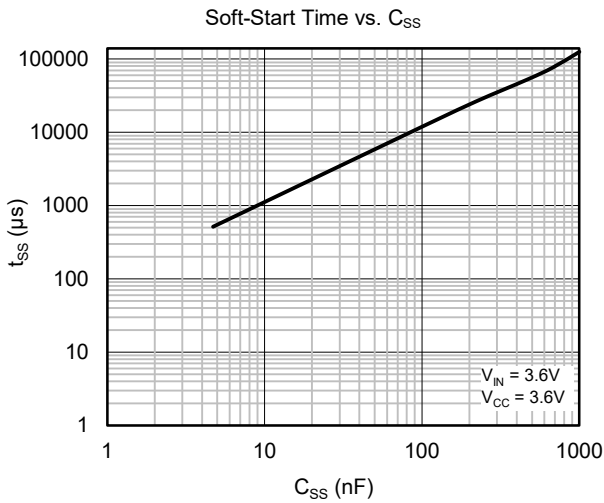
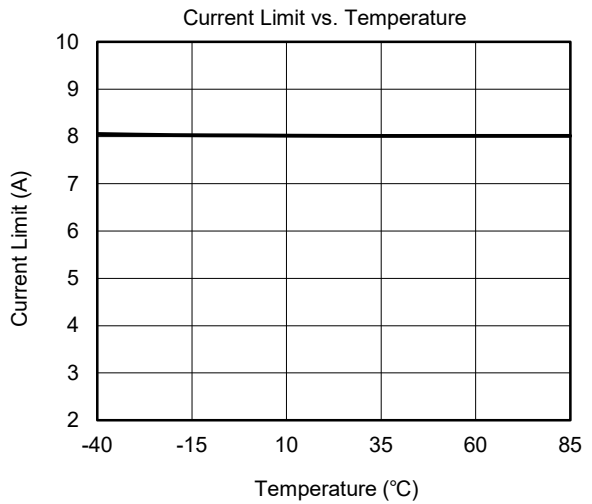
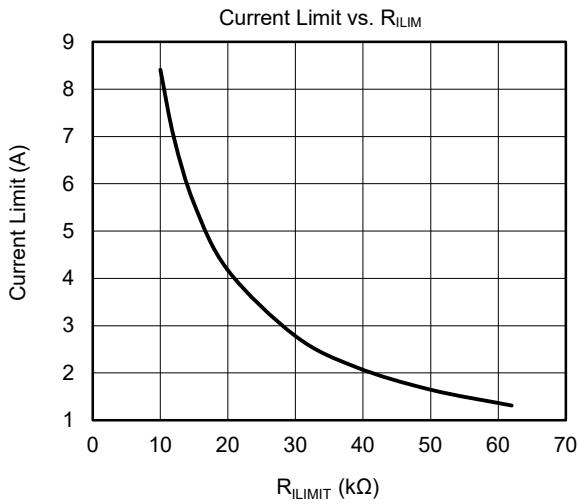
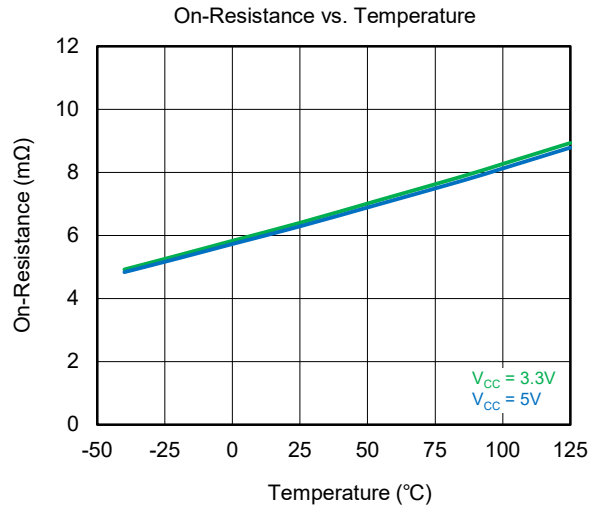
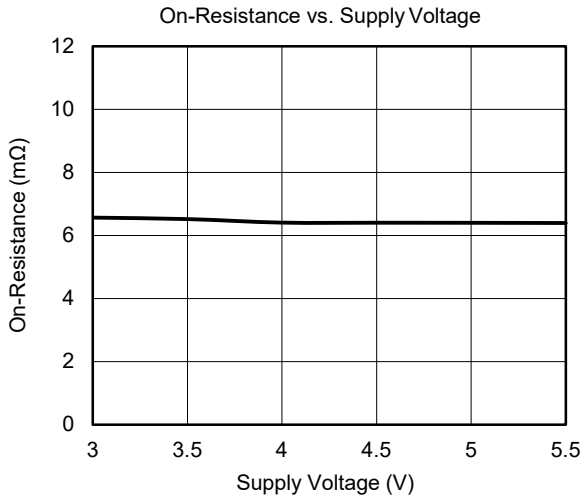

# 5.5V, 7A Low $R_{DS(ON)}$ Load Switch with Programmable Current Limit, Power Good, and Output Discharge Function

## SGM25007A

### TYPICAL PERFORMANCE CHARACTERISTICS (continued)

$T_J = +25^\circ\text{C}$ , unless otherwise noted.

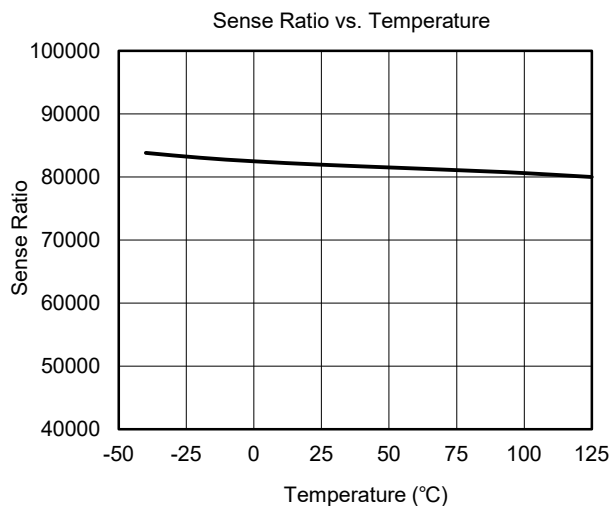
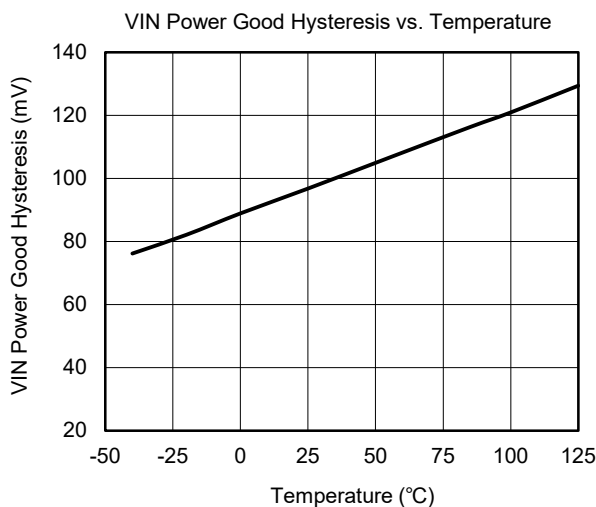
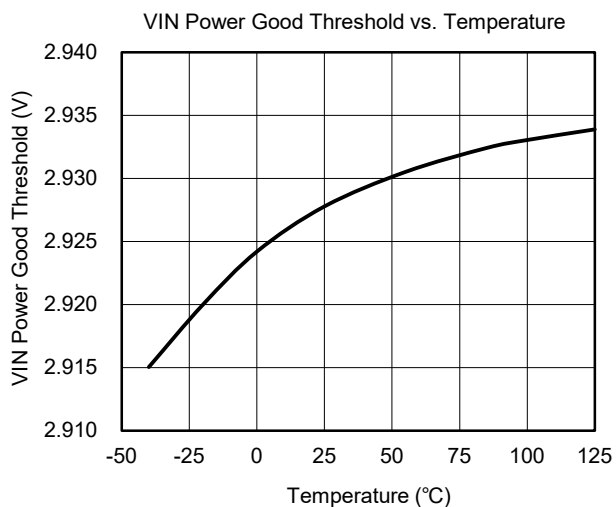

# 5.5V, 7A Low $R_{DS(ON)}$ Load Switch with Programmable Current Limit, Power Good, and Output Discharge Function

## TYPICAL PERFORMANCE CHARACTERISTICS (continued)

$T_J = +25^\circ\text{C}$ , unless otherwise noted.

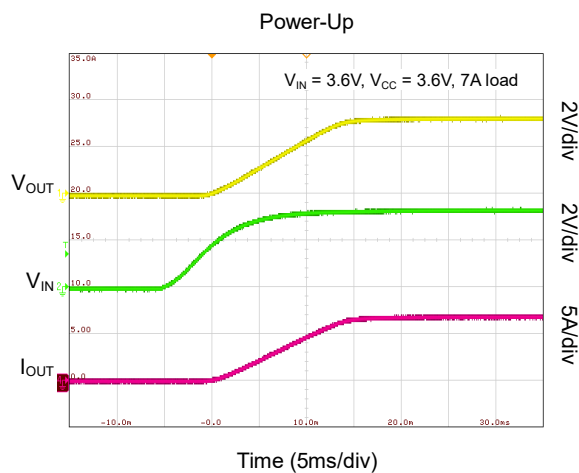
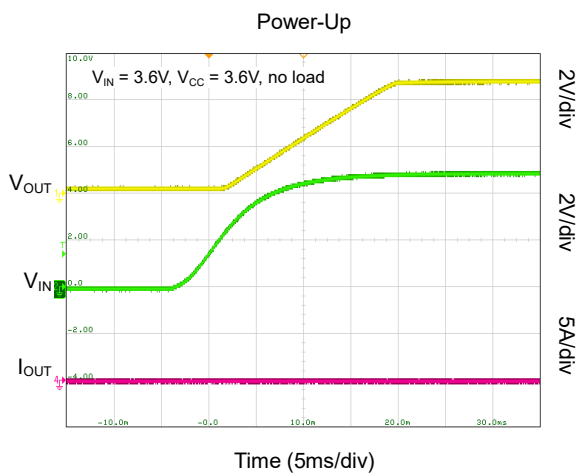
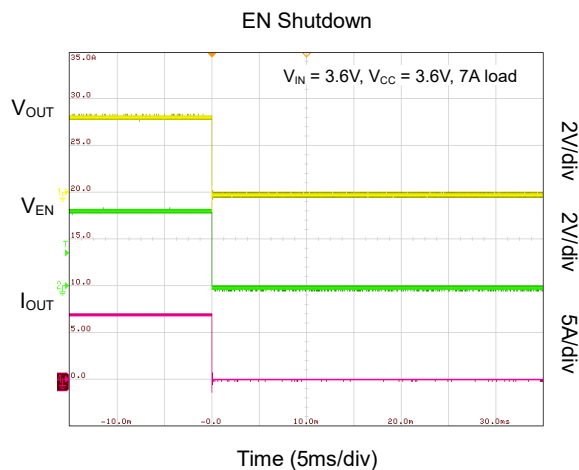
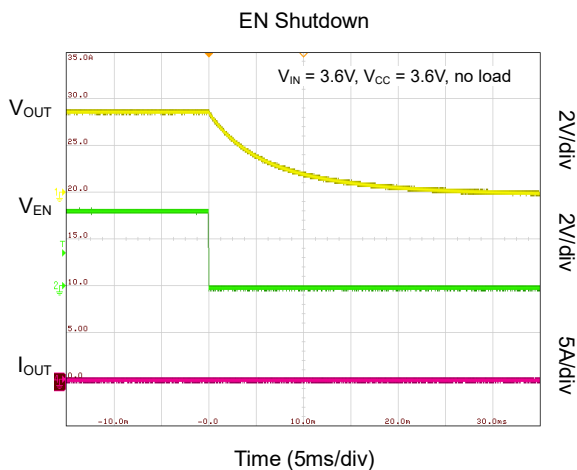
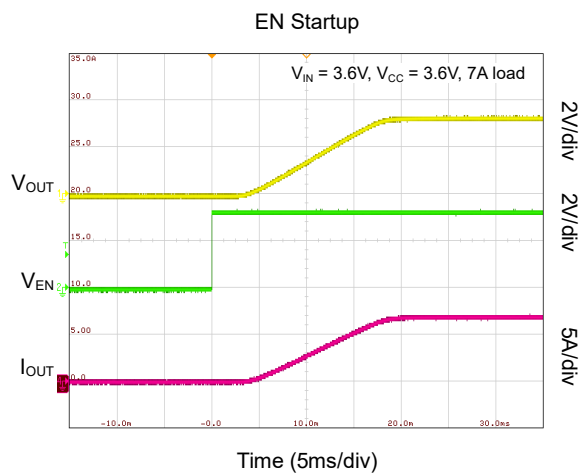
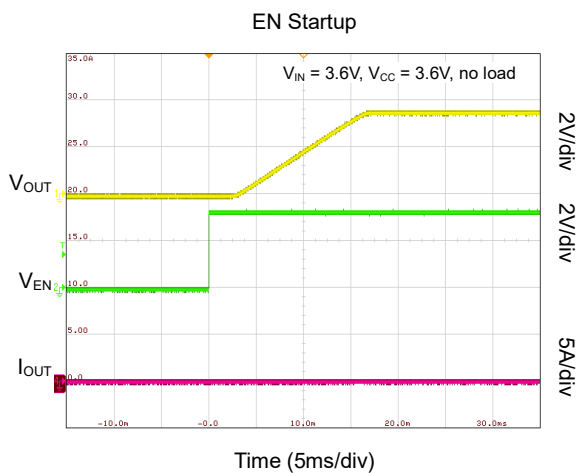

# 5.5V, 7A Low $R_{DS(ON)}$ Load Switch with Programmable Current Limit, Power Good, and Output Discharge Function

## TYPICAL PERFORMANCE CHARACTERISTICS (continued)

$T_J = +25^\circ\text{C}$ , unless otherwise noted.

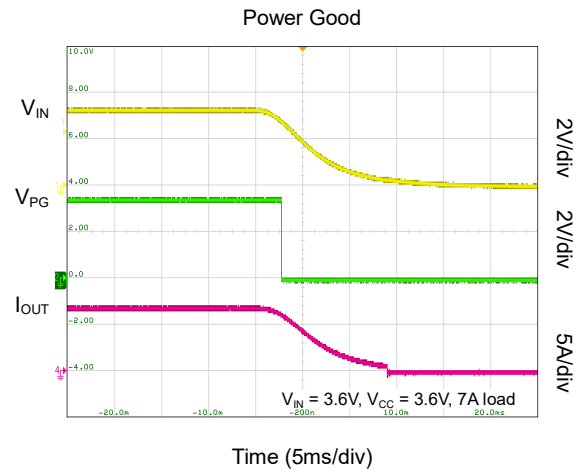
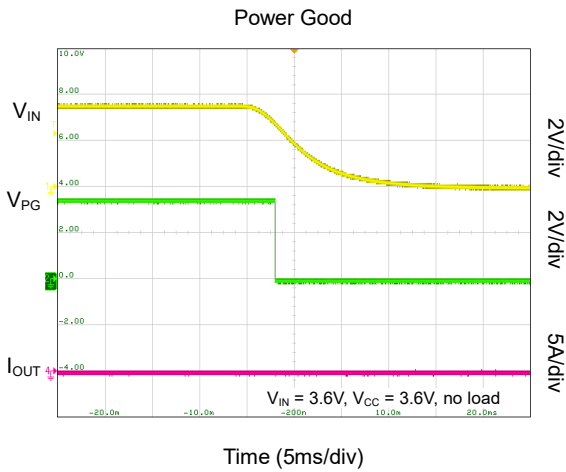
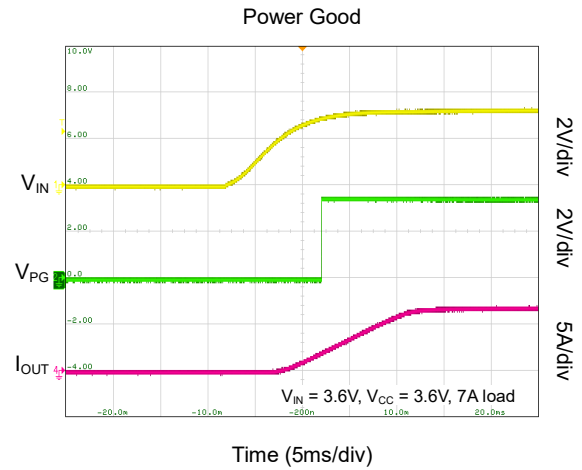
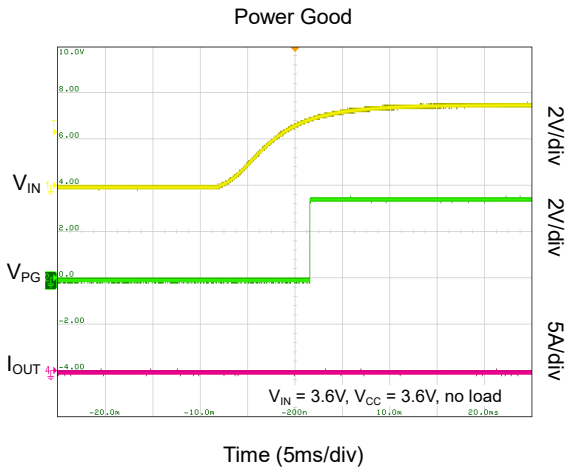
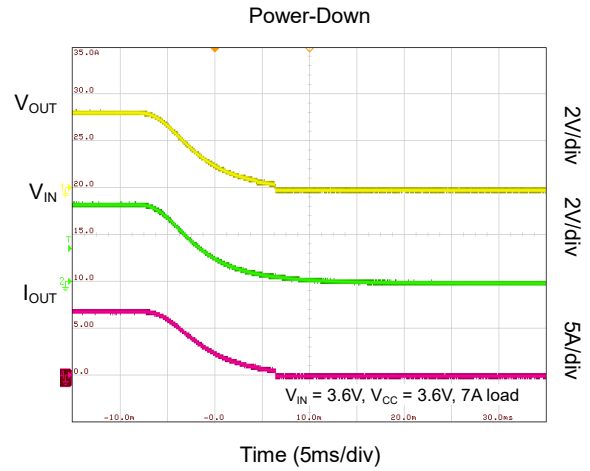
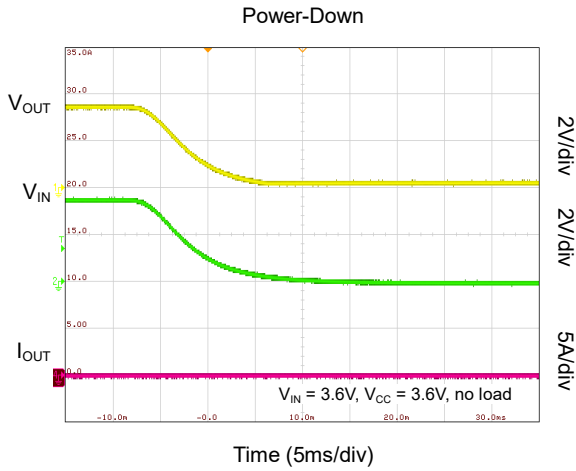

# 5.5V, 7A Low $R_{DS(ON)}$ Load Switch with Programmable Current Limit, SGM25007A

## TYPICAL PERFORMANCE CHARACTERISTICS (continued)

$T_J = +25^\circ\text{C}$ , unless otherwise noted.

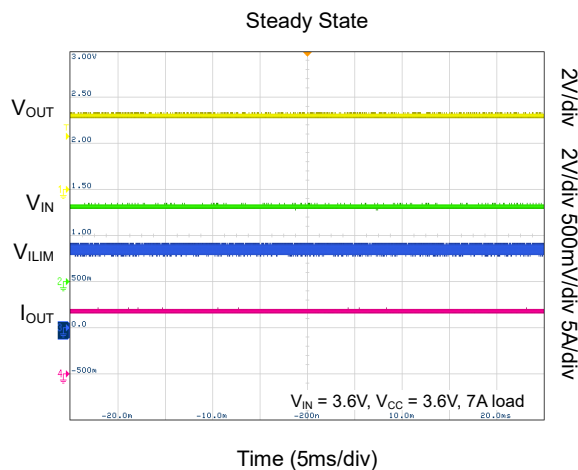
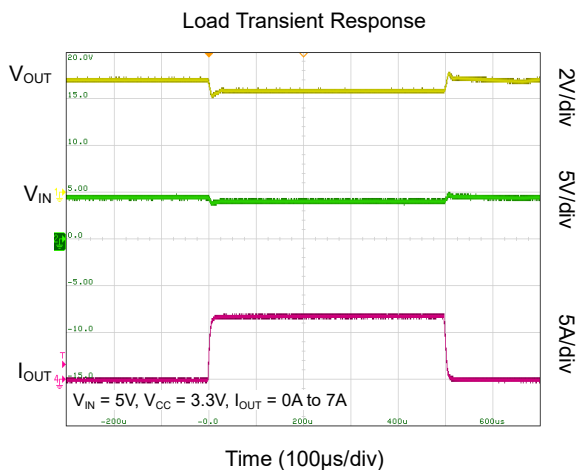
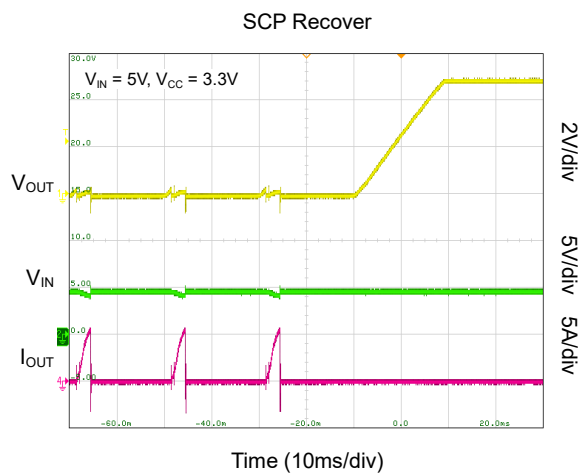
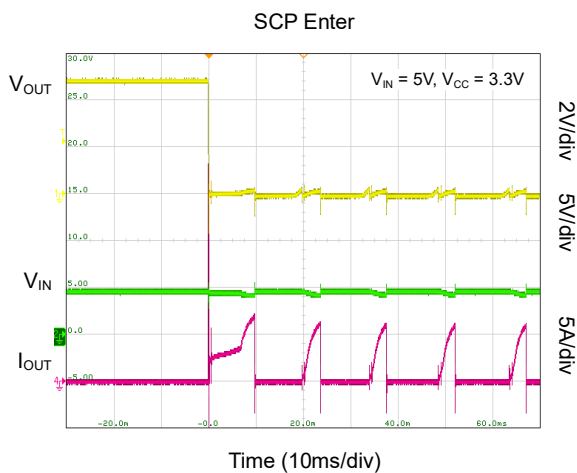

# 5.5V, 7A Low $R_{DS(ON)}$ Load Switch with Programmable Current Limit, SGM25007A

## FUNCTIONAL BLOCK DIAGRAM

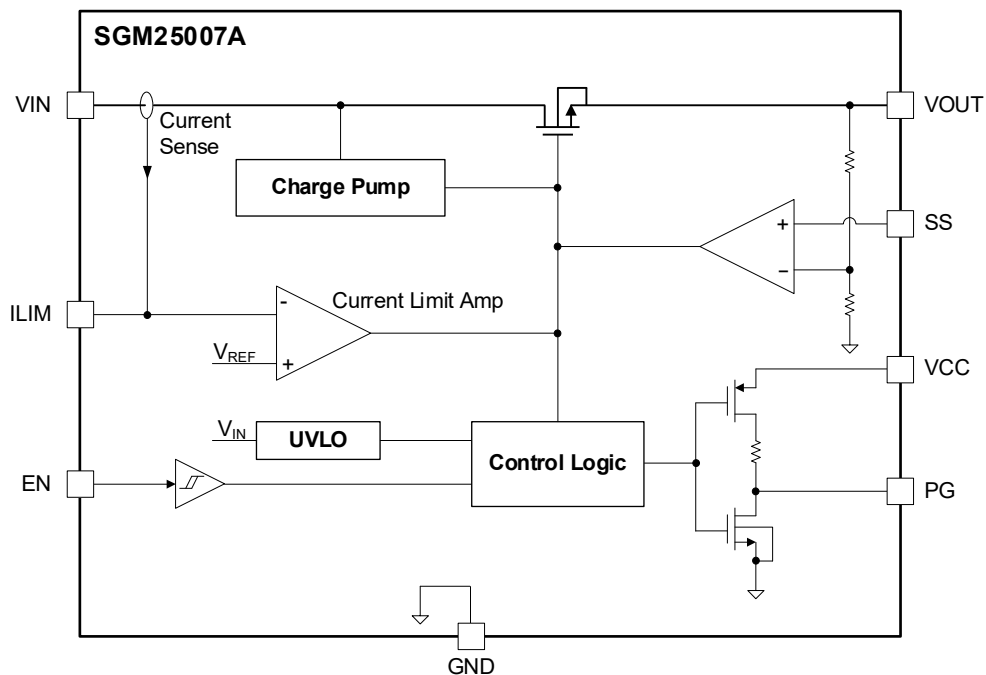

Figure 2. Block Diagram

# 5.5V, 7A Low $R_{\text{DS(on)}}$ Load Switch with Programmable Current Limit, Power Good, and Output Discharge Function

---

## DETAILED DESCRIPTION

The SGM25007A is used to solve the inrush current issue to the load when the circuit card is inserted into a live backplane power supply, which can limit the backplane's voltage drop and the slew rate of the load voltage. It can monitor the input voltage, output voltage and output current which can eliminate the external power device and current sense device.

### Enable

If VIN voltage and VCC voltage meet the starting condition, SGM25007A can be enabled when EN pin is high. When EN pin is low, SGM25007A is disabled.

### Current Limit

The SGM25007A is internally integrated with a constant current limit function that can be configured via external resistors. When the load current reaches the current limit threshold, the SGM25007A will limit the current below the current limit threshold by regulating the gate voltage of power device. The current limit will not be triggered in the response time of 20 $\mu$ s. A small overshoot of the load current during this period is allowed.

Set the current limit threshold using Equation 1.

$$I_{\text{LIMIT}}(\text{A}) = \frac{87122}{R_{\text{ILIM}}^{1.015}(\Omega)} \quad (1)$$

If the load current limit is triggered, the power loss of power device will increase and the IC temperature will rise accordingly. The device will be shut off when the junction temperature ( $T_J$ ) is higher than +150°C and will not recover until  $T_J$  is lower than +130°C.

### Power Good Function

The PG (power good) pin operates as a push-pull output capable of being actively driven to VCC potential. The VIN sense input features direct internal connection to monitor system supply voltage in real-time. When the VIN voltage exceeds the 3V threshold, the PG pin asserts a valid high signal. Integrated threshold hysteresis with voltage rejection characteristics ensures immunity to transient perturbations on the VIN pin, preventing false triggering events.

### Short-Circuit Protection

If the output is shorted to GND, the load current will increase rapidly in a short time. Before the current limit function responds, the power device current may be much higher than the current limit threshold which may cause serious damage. To solve this problem, SGM25007A integrates a fast turn-off circuit. When load current exceeds the secondary current limit level (about 9.6A), power device will be turned off, which can avoid input voltage drop. The total response time of short-circuit protection is about 200ns. If fast turn-off circuit works, the power device will be turned off for 260 $\mu$ s, then power device will be turned on again. If output short-circuit condition still exists, SGM25007A will reduce the current below the pre-set current limit threshold, and keep it until thermal shutdown happens.

### Output Discharge

SGM25007A integrates output discharge function which is achieved through an internal pull-down resistor. It helps to discharge the  $V_{\text{OUT}}$  when IC is disabled with very light load.

### Soft-Start

An external capacitor ( $C_{\text{SS}}$ ) between SS and GND pins will set the soft-start time according to the application requirements.

During the soft-start phase, an internal 9 $\mu$ A constant current source begins to charge SS capacitor. The SS pin voltage starts to ramp up accordingly. The slew rate of output voltage is about 3 times that of SS voltage.

The soft-start time is calculated by:

$$t_{\text{SS}}(\text{ms}) = \frac{1}{3} \times \frac{V_{\text{OUT}}(\text{V}) \times C_{\text{SS}}(\text{nF})}{I_{\text{SS}}(\mu\text{A})} \quad (2)$$

where:

$I_{\text{SS}} = 9\mu\text{A}$  (TYP).

It is recommended that the SS capacitor be larger than 4.7nF. If the SS pin is floated or  $C_{\text{SS}}$  is too small, the charge time of power device will limit  $V_{\text{OUT}}$  rising time.

# 5.5V, 7A Low $R_{DS(ON)}$ Load Switch with Programmable Current Limit, SGM25007A

## APPLICATION INFORMATION

### ILIM Resistor Selection

The SGM25007A changes the current limit threshold through an external ILIM resistor. The formula of current limit threshold is approximated in Equation 1. It is recommended to set the current limit threshold to 110% ~ 120% of the maximum load current. For example, if the full load of system is 7A, the current limit threshold is set to 7.7A.

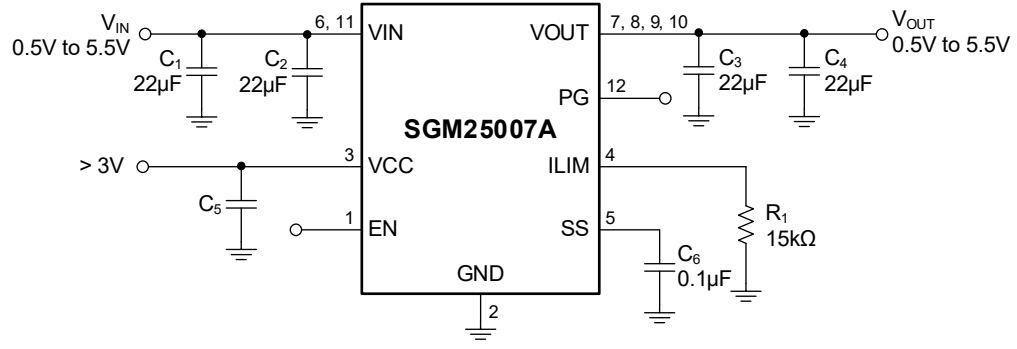

Figure 3. Typical Application

### Layout Guide

A good PCB layout can achieve stable operation of the system. Please refer to the below layout guidelines and Figure 4.

- It is recommended to place  $R_{ILIM}$  as close to the ILIM pin as possible.
- It is recommended to place VCC capacitor as close to VCC pin as possible.
- It is recommended to place enough vias around IC to help dissipate the heat.

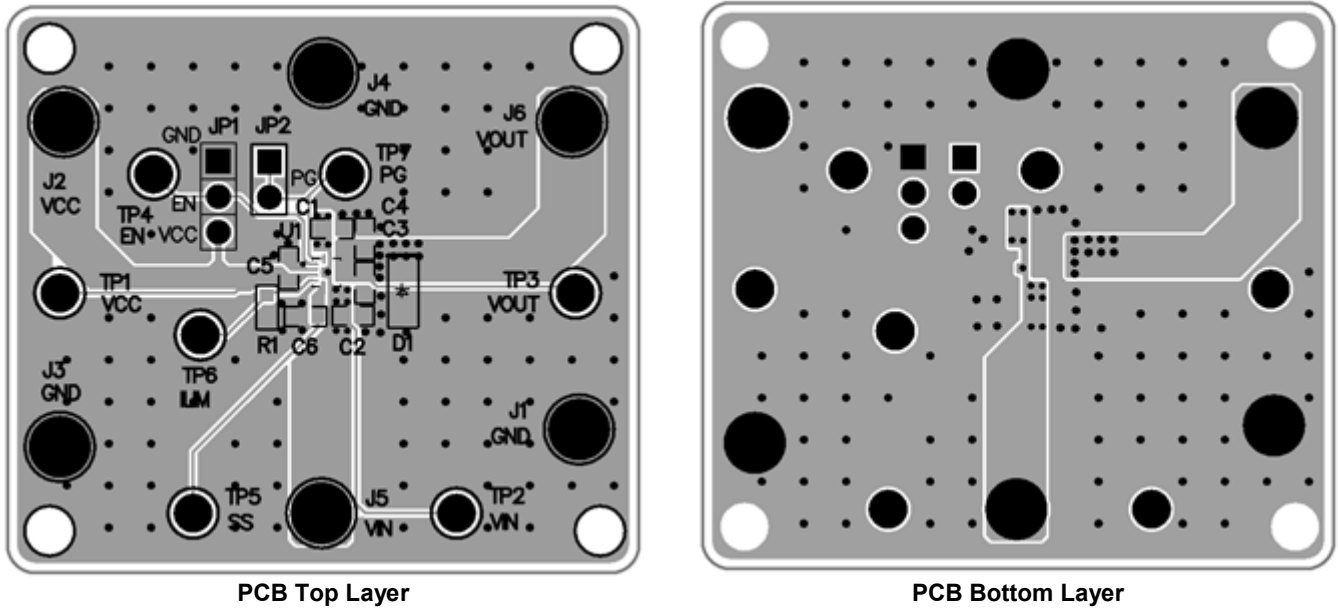

Figure 4. Recommended Layout

## REVISION HISTORY

NOTE: Page numbers for previous revisions may differ from page numbers in the current version.

Changes from Original to REV.A (APRIL 2026)	Page
Changed from product preview to production data.....	All

# PACKAGE INFORMATION

## PACKAGE OUTLINE DIMENSIONS

### TQFN-2x2-12CL

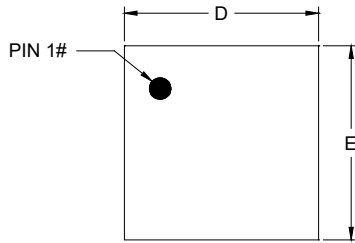

TOP VIEW

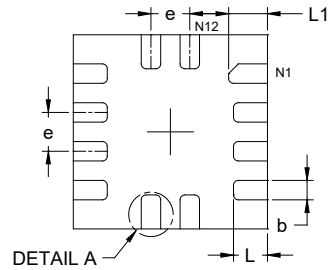

BOTTOM VIEW

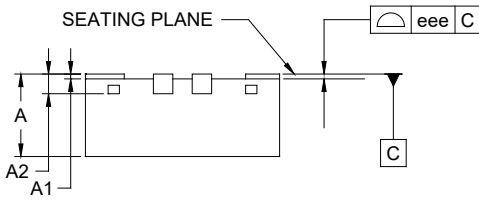

SIDE VIEW

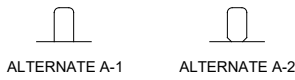

DETAIL A  
ALTERNATE TERMINAL  
CONSTRUCTION

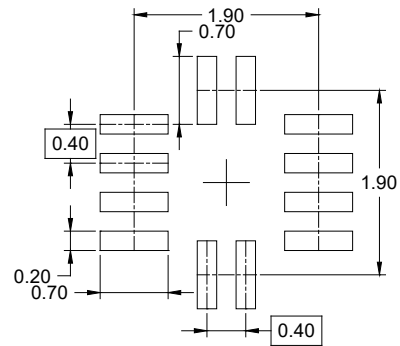

RECOMMENDED LAND PATTERN (Unit: mm)

Symbol	Dimensions In Millimeters		
	MIN	NOM	MAX
A	0.800	-	0.900
A1	0.000	-	0.050
A2	0.203 REF		
b	0.150	-	0.250
D	1.900	-	2.100
E	1.900	-	2.100
e	0.400 BSC		
L	0.250	-	0.450
L1	0.300	-	0.500
eee	0.080		

NOTE: This drawing is subject to change without notice.

TAPE AND REEL INFORMATION

REEL DIMENSIONS

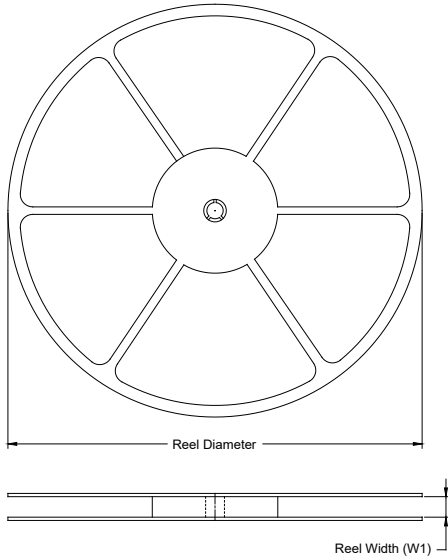

TAPE DIMENSIONS

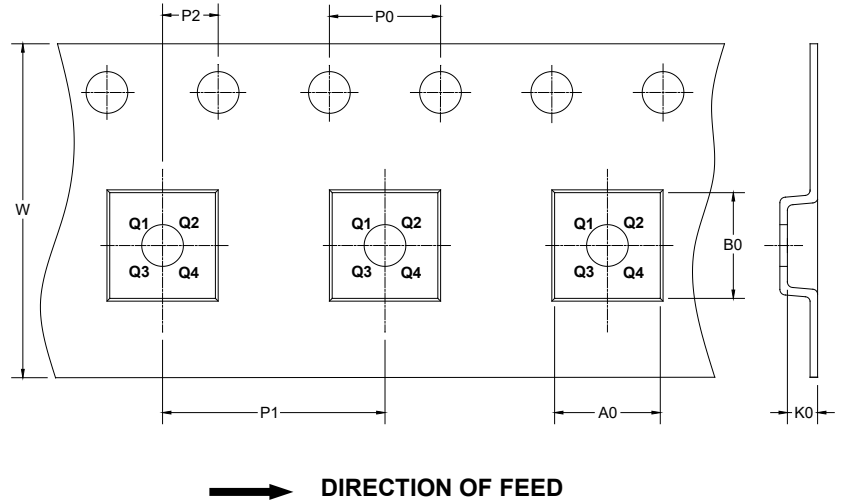

NOTE: The picture is only for reference. Please make the object as the standard.

KEY PARAMETER LIST OF TAPE AND REEL

Package Type	Reel Diameter	Reel Width W1 (mm)	A0 (mm)	B0 (mm)	K0 (mm)	P0 (mm)	P1 (mm)	P2 (mm)	W (mm)	Pin1 Quadrant
TQFN-2x2-12CL	13"	12.4	2.20	2.20	1.14	4.0	8.0	2.0	12.0	Q1

DD0001

# PACKAGE INFORMATION

## CARTON BOX DIMENSIONS

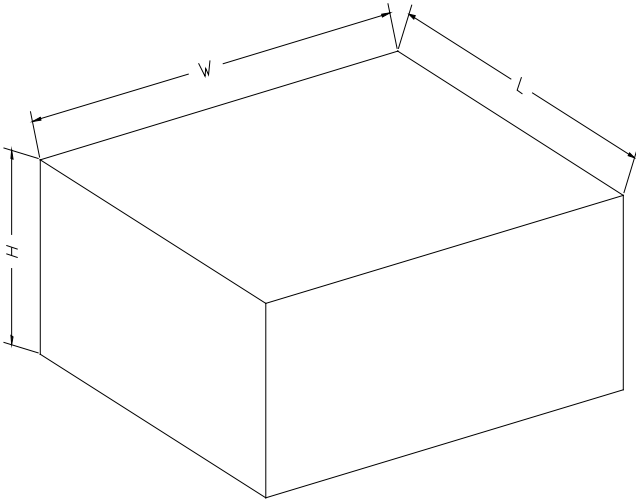

NOTE: The picture is only for reference. Please make the object as the standard.

## KEY PARAMETER LIST OF CARTON BOX

Reel Type	Length (mm)	Width (mm)	Height (mm)	Pizza/Carton
13"	386	280	370	5

DD0002