



SGM44603

4.5Ω, High Speed, Low Voltage Quad, SPDT Analog Switch

GENERAL DESCRIPTION

The SGM44603 is a quad, SPDT (single-pole/double-throw), TTL/CMOS compatible analog switch. It operates from a 1.8V to 5.5V single power supply.

The SGM44603 features high-speed, low on-resistance, low voltage and high bandwidth. The high performances make it very suitable for multiple applications, such as portable equipment, audio and video signal routing, etc. Low power consumption is also one of the important reasons that make it a good choice.

The SGM44603 is available in a Green TQFN-2.6×1.8-16L package. It operates over an ambient temperature range of -40°C to +85°C.

FEATURES

- **Single Supply Voltage Range: 1.8V to 5.5V**
- **-3dB Bandwidth: 300MHz**
- **Low On-Resistance: 4.5Ω (TYP) at 5V**
- **Low On-Resistance Flatness**
- **High Off-Isolation: -70dB at 1MHz**
- **Low Crosstalk: -90dB at 1MHz**
- **Fast Switching Times:**
 - t_{ON}: 40ns**
 - t_{OFF}: 30ns**
- **Rail-to-Rail Input and Output Operation**
- **Low Power Consumption**
- **TTL/CMOS Compatible**
- **-40°C to +85°C Operating Temperature Range**
- **Available in a Green TQFN-2.6×1.8-16L Package**

APPLICATIONS

Cellular Phones
Portable Equipment
Computer Peripherals
Sample-and-Hold Circuits
Personal Digital Assistants
USB 1.1 Signal Switching Circuits
Battery-Powered Systems
Audio and Video Signal Routing

PACKAGE/ORDERING INFORMATION

MODEL	PACKAGE DESCRIPTION	SPECIFIED TEMPERATURE RANGE	ORDERING NUMBER	PACKAGE MARKING	PACKING OPTION
SGM44603	TQFN-2.6x1.8-16L	-40°C to +85°C	SGM44603YTQA16/TR	44603 XXXXX	Tape and Reel, 3000

MARKING INFORMATION

NOTE: XXXXX = Date Code and Vendor Code.

XXXXX

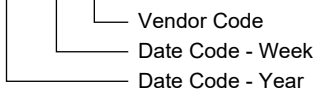

Green (RoHS & HSF): SG Micro Corp defines "Green" to mean Pb-Free (RoHS compatible) and free of halogen substances. If you have additional comments or questions, please contact your SGMICRO representative directly.

ABSOLUTE MAXIMUM RATINGS

- V₊ to GND -0.3V to 6V
- Analog, Digital Voltage Range ⁽¹⁾ -0.3V to (V₊) +0.3V
- Continuous Current NO, NC, or COM..... ±100mA
- Junction Temperature +150°C
- Storage Temperature Range -65°C to +150°C
- Lead Temperature (Soldering, 10s)..... +260°C

NOTE:

1. Signals on NC, NO, or COM or I_{Nx} exceeding V₊ will be clamped by internal diodes. Limit forward diode current to maximum current ratings.

RECOMMENDED OPERATING CONDITIONS

Operating Temperature Range -40°C to +85°C

OVERSTRESS CAUTION

Stresses beyond those listed in Absolute Maximum Ratings may cause permanent damage to the device. Exposure to absolute maximum rating conditions for extended periods may affect reliability. Functional operation of the device at any conditions beyond those indicated in the Recommended Operating Conditions section is not implied.

ESD SENSITIVITY CAUTION

This integrated circuit can be damaged by ESD if you don't pay attention to ESD protection. SGMICRO recommends that all integrated circuits be handled with appropriate precautions. Failure to observe proper handling and installation procedures can cause damage. ESD damage can range from subtle performance degradation to complete device failure. Precision integrated circuits may be more susceptible to damage because very small parametric changes could cause the device not to meet its published specifications.

DISCLAIMER

SG Micro Corp reserves the right to make any change in circuit design, or specifications without prior notice.

PIN CONFIGURATION

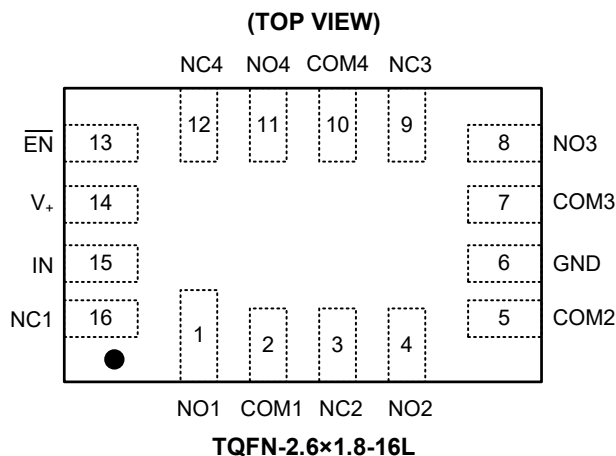

PIN DESCRIPTION

PIN	NAME	FUNCTION
14	V ₊	Positive Power Supply.
6	GND	Ground.
15	IN	Digital Control Input Pin to Connect the COM Pins to the NO or NC Pins.
13	$\overline{\text{EN}}$	Digital Enable Control. Normally connect to GND. Drive to logic high to set all switches off.
2, 5, 7, 10	COM _x	Common Pins.
1, 4, 8, 11	NO _x	Normally Open Pins.
16, 3, 9, 12	NC _x	Normally Closed Pins.

NOTE: NO_x, NC_x and COM_x pins may be an input or output.

FUNCTION TABLE

$\overline{\text{EN}}$	IN	NO	NC
L	L	OFF	ON
L	H	ON	OFF
H	√	All Switches Open	

√ = Don't Care.

ELECTRICAL CHARACTERISTICS

($V_+ = +4.5V$ to $+5.5V$, $GND = 0V$, $V_{IH} = +1.6V$, $V_{IL} = +0.5V$, Full = $-40^\circ C$ to $+85^\circ C$. Typical values are at $V_+ = +5.0V$, $T_A = +25^\circ C$, unless otherwise noted.)

PARAMETER	SYMBOL	CONDITIONS	TEMP	MIN	TYP	MAX	UNITS
Analog Switch							
Analog Signal Range	V_{NO}, V_{NC}, V_{COM}		Full	0		V_+	V
On-Resistance	R_{ON}	$V_+ = 4.5V, 0V \leq V_{NO} \text{ or } V_{NC} \leq V_+, I_{COM} = -100mA$, Test Circuit 1	$+25^\circ C$		4.5	7	Ω
			Full			8	
On-Resistance Match between Channels	ΔR_{ON}	$V_+ = 4.5V, 0V \leq V_{NO} \text{ or } V_{NC} \leq V_+, I_{COM} = -100mA$, Test Circuit 1	$+25^\circ C$		0.8	3.6	Ω
			Full			4.2	
On-Resistance Flatness	$R_{FLAT(ON)}$	$V_+ = 4.5V, 0V \leq V_{NO} \text{ or } V_{NC} \leq V_+, I_{COM} = -100mA$, Test Circuit 1	$+25^\circ C$		3	3.7	Ω
			Full			4.5	
Source Off Leakage Current	$I_{NC(OFF)}, I_{NO(OFF)}$	$V_+ = 5.5V, V_{NO} \text{ or } V_{NC} = 3.3V/0.3V, V_{COM} = 0.3V/3.3V$	Full			1	μA
Channel On Leakage Current	$I_{NC(ON)}, I_{NO(ON)}, I_{COM(ON)}$	$V_+ = 5.5V, V_{COM} = 0.3V/3.3V, V_{NO} \text{ or } V_{NC} = 0.3V/3.3V$ or floating	Full			1	μA
Digital Inputs							
Input High Voltage	V_{INH}		Full	1.6			V
Input Low Voltage	V_{INL}		Full			0.5	V
Input Leakage Current	I_{IN}	$V_+ = 5.5V, V_{IN}, V_{EN} = 0V$ or V_+	Full			1	μA
Dynamic Characteristics							
Turn-On Time	t_{ON}	$V_{NO} \text{ or } V_{NC} = 3V, C_L = 35pF, R_L = 300\Omega$, Test Circuit 2	$+25^\circ C$		40		ns
Turn-Off Time	t_{OFF}		$+25^\circ C$		30		ns
Charge Injection Select Input to Common I/O	Q	$V_S = GND, R_S = 0\Omega, C_L = 1nF, Q = C_L \times V_{OUT}$, Test Circuit 3	$+25^\circ C$		20		pC
Break-Before-Make Time Delay	t_D	$V_{NO} \text{ or } V_{NC} = 3V, R_L = 300\Omega, C_L = 35pF$, Test Circuit 4	$+25^\circ C$		18		ns
Off Isolation	O_{ISO}	$R_L = 50\Omega$, Signal = 0dBm, Test Circuit 5	1MHz	$+25^\circ C$		-70	dB
			10MHz	$+25^\circ C$		-50	
Channel-to-Channel Crosstalk	X_{TALK}	$R_L = 50\Omega$, Signal = 0dBm, Test Circuit 6	1MHz	$+25^\circ C$		-90	dB
			10MHz	$+25^\circ C$		-60	
-3dB Bandwidth	BW	$R_L = 50\Omega$, Signal = 0dBm, Test Circuit 7	$+25^\circ C$		300		MHz
Channel On Capacitance	C_{ON}		$+25^\circ C$		64		pF
Power Requirements							
Power Supply Range	V_+		Full	1.8		5.5	V
Power Supply Current	I_+	$V_+ = 5.5V, V_S, V_{EN} = 0V$ or V_+	Full			1	μA

ELECTRICAL CHARACTERISTICS (continued)

($V_+ = +2.7V$ to $+3.6V$, $V_{IH} = +1.6V$, $V_{IL} = +0.4V$, Full = $-40^\circ C$ to $+85^\circ C$. Typical values are at $V_+ = +3.0V$, $T_A = +25^\circ C$, unless otherwise noted.)

PARAMETER	SYMBOL	CONDITIONS	TEMP	MIN	TYP	MAX	UNITS
Analog Switch							
Analog Signal Range	V_{NO}, V_{NC}, V_{COM}		Full	0		V_+	V
On-Resistance	R_{ON}	$V_+ = 2.7V, 0V \leq V_{NO} \text{ or } V_{NC} \leq V_+, I_{COM} = -100mA, \text{ Test Circuit 1}$	+25°C		11	15.5	Ω
			Full			18.5	
On-Resistance Match between Channels	ΔR_{ON}	$V_+ = 2.7V, 0V \leq V_{NO} \text{ or } V_{NC} \leq V_+, I_{COM} = -100mA, \text{ Test Circuit 1}$	+25°C		1.6	4	Ω
			Full			4.6	
On-Resistance Flatness	$R_{FLAT(ON)}$	$V_+ = 2.7V, 0V \leq V_{NO} \text{ or } V_{NC} \leq V_+, I_{COM} = -100mA, \text{ Test Circuit 1}$	+25°C		7	9.4	Ω
			Full			13	
Source Off Leakage Current	$I_{NC(OFF)}, I_{NO(OFF)}$	$V_+ = 3.6V, V_{NO} \text{ or } V_{NC} = 3.3V/0.3V, V_{COM} = 0.3V/3.3V$	Full			1	μA
Channel On Leakage Current	$I_{NC(ON)}, I_{NO(ON)}, I_{COM(ON)}$	$V_+ = 3.6V, V_{COM} = 0.3V/3.3V, V_{NO} \text{ or } V_{NC} = 0.3V/3.3V \text{ or floating}$	Full			1	μA
Digital Inputs							
Input High Voltage	V_{INH}		Full	1.5			V
Input Low Voltage	V_{INL}		Full			0.4	V
Input Leakage Current	I_{IN}	$V_+ = 2.7V, V_{IN}, V_{EN} = 0V \text{ or } V_+$	Full			1	μA
Dynamic Characteristics							
Turn-On Time	t_{ON}	$V_{NO} \text{ or } V_{NC} = 1.5V, C_L = 35pF, R_L = 300\Omega, \text{ Test Circuit 2}$	+25°C		48		ns
Turn-Off Time	t_{OFF}		+25°C		45		ns
Charge Injection Select Input to Common I/O	Q	$V_S = GND, R_S = 0\Omega, C_L = 1nF, Q = C_L \times V_{OUT}, \text{ Test Circuit 3}$	+25°C		20		pC
Break-Before-Make Time Delay	t_D	$V_{NO} \text{ or } V_{NC} = 1.5V, R_L = 300\Omega, C_L = 35pF, \text{ Test Circuit 4}$	+25°C		20		ns
Off Isolation	O_{ISO}	$R_L = 50\Omega, \text{ Signal} = 0dBm, \text{ Test Circuit 5}$	1MHz	+25°C		-70	dB
			10MHz	+25°C		-50	
Channel-to-Channel Crosstalk	X_{TALK}	$R_L = 50\Omega, \text{ Signal} = 0dBm, \text{ Test Circuit 6}$	1MHz	+25°C		-90	dB
			10MHz	+25°C		-60	
-3dB Bandwidth	BW	$R_L = 50\Omega, \text{ Signal} = 0dBm, \text{ Test Circuit 7}$	+25°C		300		MHz
Channel On Capacitance	C_{ON}		+25°C		64		pF

TYPICAL PERFORMANCE CHARACTERISTICS

On Response vs. Frequency

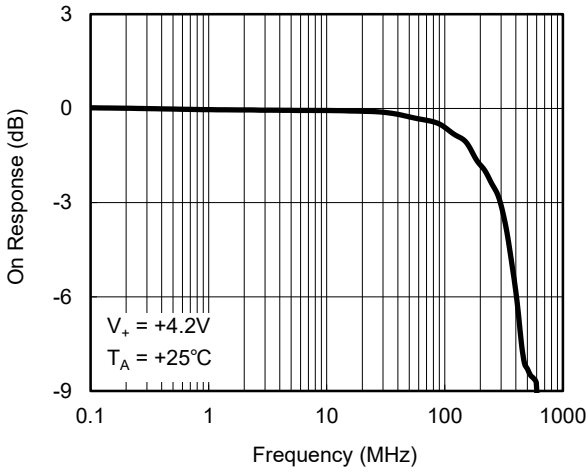

On Response vs. Frequency

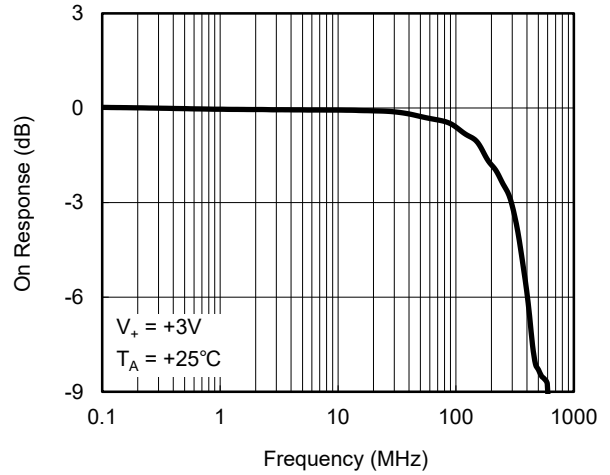

Response vs. Frequency

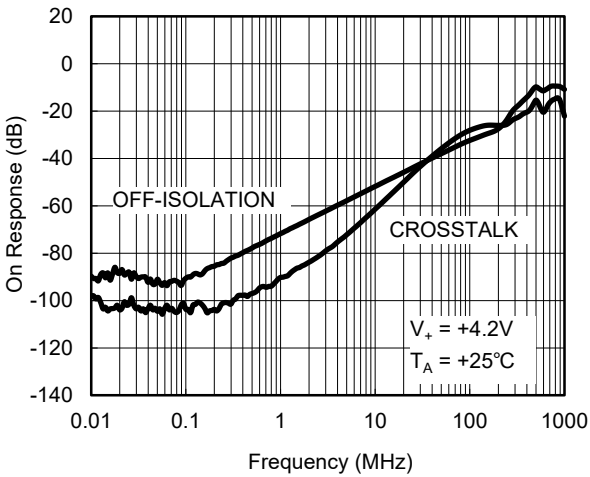

Response vs. Frequency

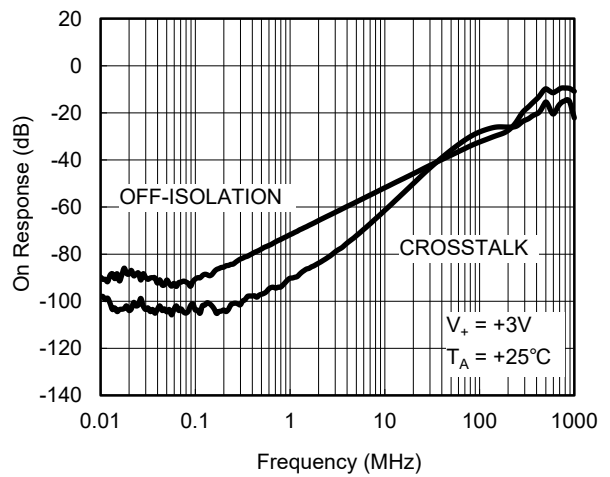

TEST CIRCUITS

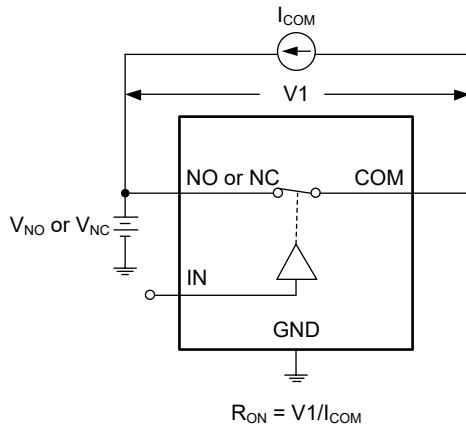

Test Circuit 1. On-Resistance

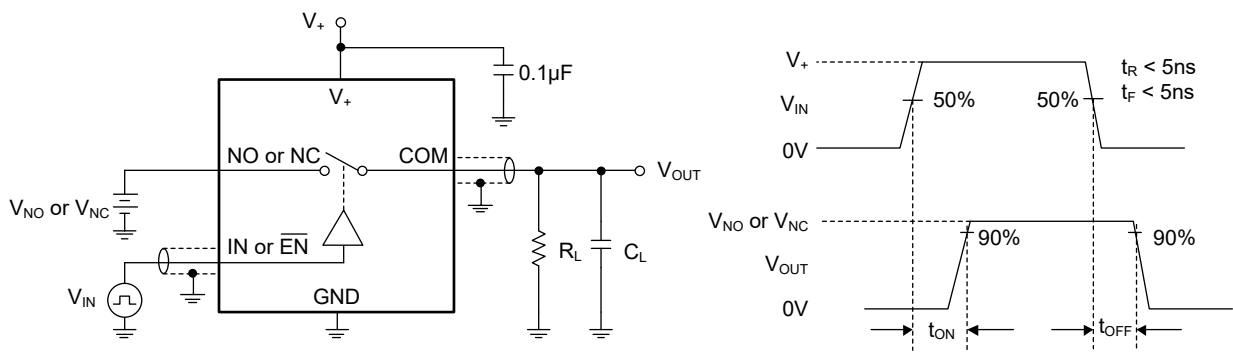

Test Circuit 2. Switching Times

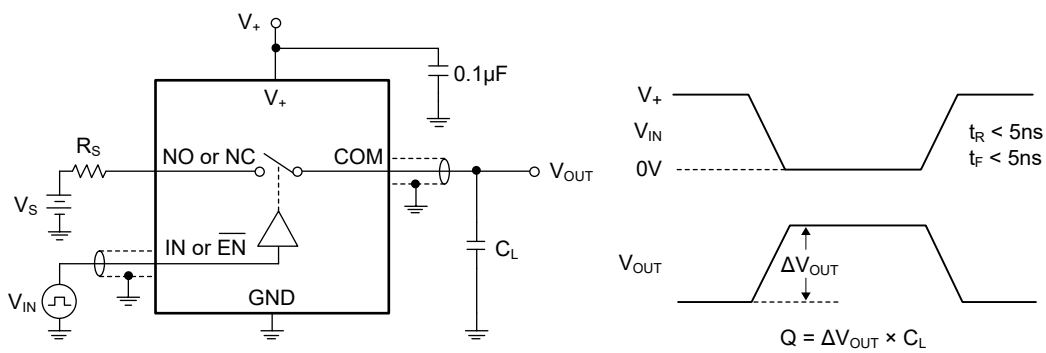

Test Circuit 3. Charge Injection

TEST CIRCUITS (continued)

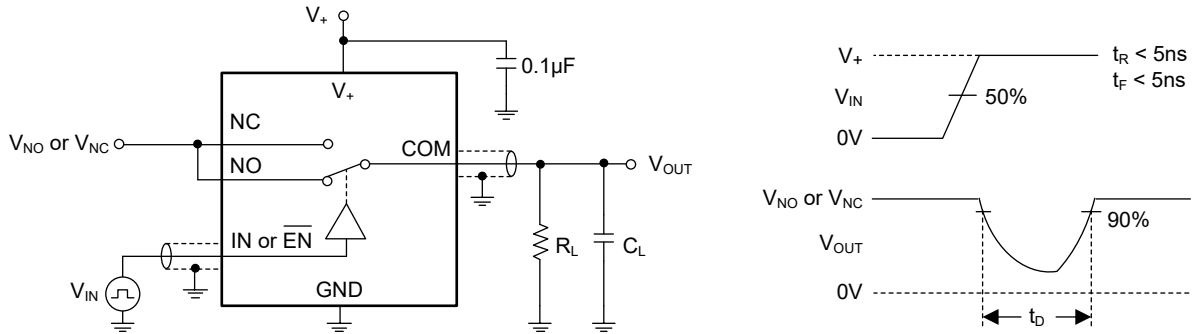

Test Circuit 4. Break-Before-Make Time Delay (t_D)

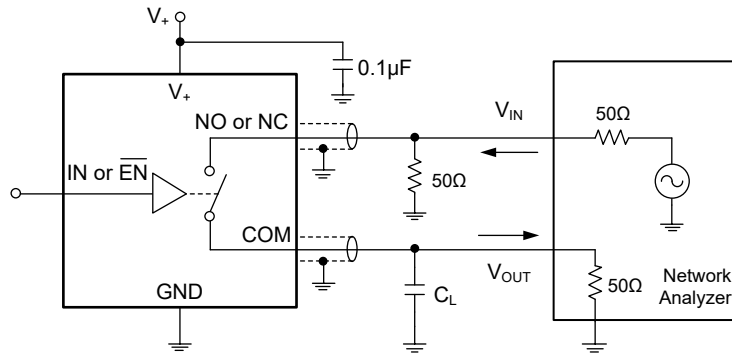

Test Circuit 5. Off Isolation

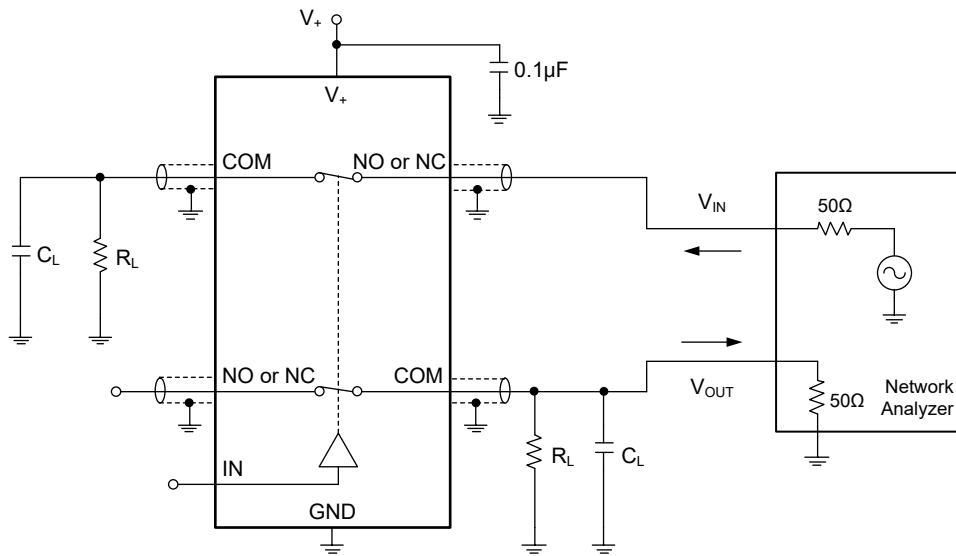

$$\text{Channel-to-Channel Crosstalk} = -20 \log (V_{NO} \text{ or } V_{NC}/V_{OUT})$$

Test Circuit 6. Channel-to-Channel Crosstalk

TEST CIRCUITS (continued)

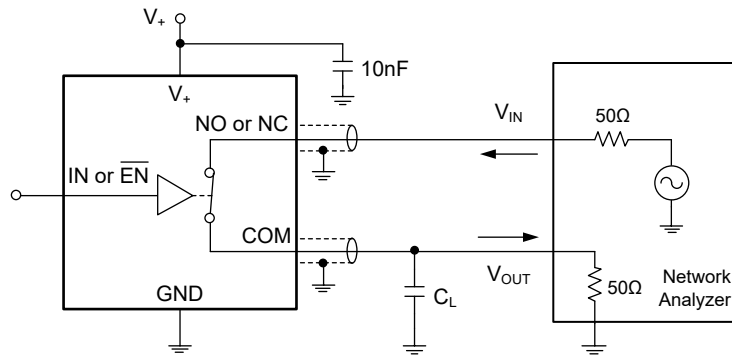

Test Circuit 7. -3dB Bandwidth

REVISION HISTORY

NOTE: Page numbers for previous revisions may differ from page numbers in the current version.

MAY 2016 – REV.A.3 to REV.A.4	Page
Updated Package Outline Dimensions section	10
Updated Tape and Reel Information section	12
JANUARY 2013 – REV.A.2 to REV.A.3	Page
Updated Package Outline Dimensions section	10
Updated Tape and Reel Information section	11, 12
MAY 2011 – REV.A.1 to REV.A.2	Page
Updated package name	All
DECEMBER 2008 – REV.A to REV.A.1	Page
Updated typeset	All
Changes from Original (MAY 2008) to REV.A	Page
Changed from product preview to production data	All

PACKAGE OUTLINE DIMENSIONS

TQFN-2.6×1.8-16L

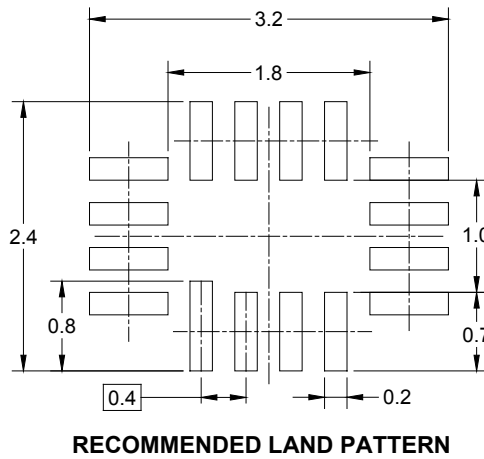
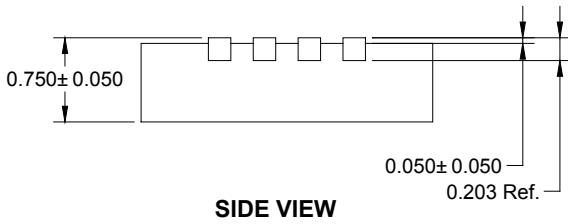
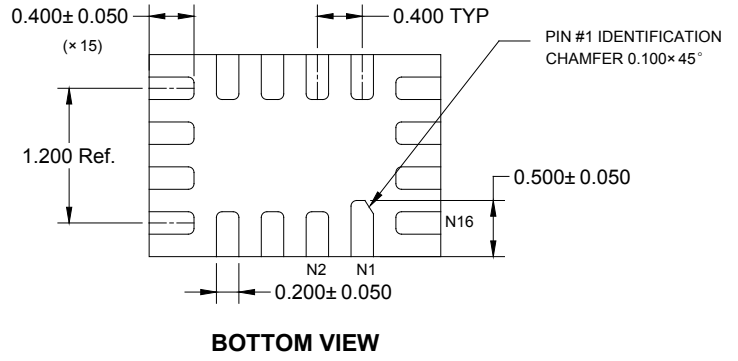
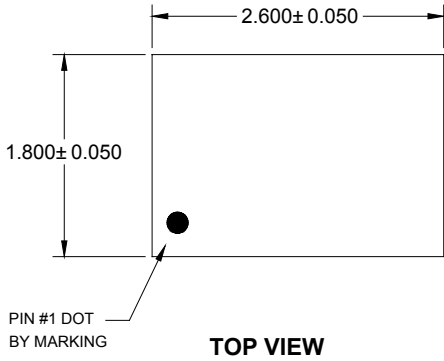

NOTE: All linear dimensions are in millimeters.

PACKAGE INFORMATION

TAPE AND REEL INFORMATION

REEL DIMENSIONS



TAPE DIMENSIONS



NOTE: The picture is only for reference. Please make the object as the standard.

KEY PARAMETER LIST OF TAPE AND REEL

Package Type	Reel Diameter	Reel Width W1 (mm)	A0 (mm)	B0 (mm)	K0 (mm)	P0 (mm)	P1 (mm)	P2 (mm)	W (mm)	Pin1 Quadrant
TQFN-2.6×1.8-16L	7"	9.0	2.01	2.81	0.93	4.0	4.0	2.0	8.0	Q1

DD0001

PACKAGE INFORMATION

CARTON BOX DIMENSIONS



NOTE: The picture is only for reference. Please make the object as the standard.

KEY PARAMETER LIST OF CARTON BOX

Reel Type	Length (mm)	Width (mm)	Height (mm)	Pizza/Carton
7" (Option)	368	227	224	8
7"	442	410	224	18

DD0002