

FEATURES

- AEC-Q101 Qualified
- E-Mode Transistor-Normally off Power Switch
- Ultra High Switching Frequency
- No Reverse-Recovery Charge
- Low Gate Charge, Low Output Charge
- ESD Safeguard
- RoHS Compliant and Halogen Free

APPLICATIONS

- AC/DC Converter
- DC/DC Converter
- Totem Pole PFC
- Fast Battery Charging
- High Density Power Conversion
- High Efficiency Power Conversion

ABSOLUTE MAXIMUM RATINGS

PARAMETER	SYMBOL	VALUE	UNITS
Drain-to-Source Voltage	V_{DS}	650	V
Drain-to-Source Voltage Transient ⁽¹⁾	$V_{DS-TRANSIENT}$	800	V
Drain-to-Source Voltage (Pulse) ⁽²⁾	$V_{DS-PULSE}$	750	V
Gate-to-Source Voltage	V_{GS}	-6 to 7	V
Gate-to-Source Voltage (Pulse) ⁽³⁾	$V_{GS-PULSE}$	-20 to 10	V
Drain Current	I_D	29	A
Drain Current (Pulse) ⁽⁴⁾	I_{DM}	58	A
Total Dissipation	P_D	164	W
Junction Temperature	T_J	-55 to +150	°C
Storage Temperature Range	T_{STG}	-55 to +150	°C
Lead Temperature (Soldering, 10s)		+260	°C

Stresses beyond those listed in Absolute Maximum Ratings may cause permanent damage to the device. Exposure to absolute maximum rating conditions for extended periods may affect reliability.

NOTES:

1. $t_{PULSE} < 200\mu s$.
2. $t_{PULSE} < 100ns$, total time $< 10h$.
3. $T_J = -55^\circ C$ to $+150^\circ C$, $f = 100kHz$, open drain, $t_{PULSE} = 50ns$.
4. $V_{GS} = 6V$, $T_C = +25^\circ C$, $t_{PULSE} = 10\mu s$.

PRODUCT SUMMARY

$R_{DS(on)}$ (TYP) $V_{GS} = 6V$	$R_{DS(on)}$ (MAX) $V_{GS} = 6V$	I_D (MAX) $T_C = +25^\circ C$
60mΩ	80mΩ	29A

PIN CONFIGURATION

(TOP VIEW)

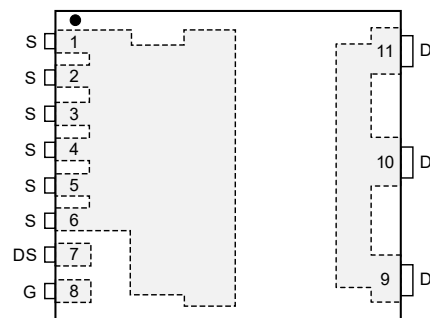

TOLL-8B

EQUIVALENT CIRCUIT

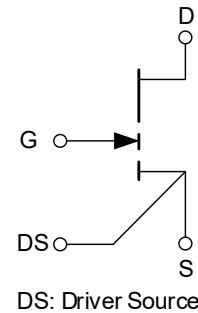

PACKAGE/ORDERING INFORMATION

MODEL	PACKAGE DESCRIPTION	SPECIFIED TEMPERATURE RANGE	ORDERING NUMBER	PACKAGE MARKING	PACKING OPTION
SGMGH60365	TOLL-8B	-55°C to +150°C	SGMGH60365TOM8G/TR	2TNOM8 XXXXX	Tape and Reel, 1200

MARKING INFORMATION

NOTE: XXXXX = Date Code, Trace Code and Vendor Code.

XXXXX

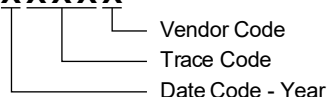

Green (RoHS & HSF): SG Micro Corp defines "Green" to mean Pb-Free (RoHS compatible) and free of halogen substances. If you have additional comments or questions, please contact your SGMICRO representative directly.

DISCLAIMER

SG Micro Corp reserves the right to make any change in circuit design, or specifications without prior notice.

THERMAL RESISTANCE

PARAMETER	SYMBOL	TYP	UNITS
Junction-to-Ambient Thermal Resistance ⁽¹⁾	R _{θJA}	57	°C/W
Junction-to-Case Thermal Resistance	R _{θJC}	0.76	°C/W

NOTE: 1. R_{θJA} is determined with the device mounted on one square inch of copper pad, single layer 2oz copper on FR4 board.

ELECTRICAL CHARACTERISTICS

(T_J = +25°C, unless otherwise noted.)

PARAMETER	SYMBOL	CONDITIONS	MIN	TYP	MAX	UNITS	
Static Characteristics							
Zero Gate Voltage Drain Current	I _{DSS}	V _{GS} = 0V, V _{DS} = 650V	T _J = +25°C	5	65	μA	
			T _J = +150°C	13	390		
Gate-to-Source Leakage Current	I _{GSS}	V _{GS} = 6V, V _{DS} = 0V		163		μA	
Gate-to-Source Threshold Voltage	V _{GS_TH}	V _{GS} = V _{DS} , I _D = 30.7mA	T _J = +25°C	1.2	1.7	2.5	V
			T _J = +150°C		1.6		
Drain-to-Source On-State Resistance	R _{DS(on)}	V _{GS} = 6V, I _D = 8A	T _J = +25°C	60	80	mΩ	
			T _J = +150°C		135		
Gate Resistance	R _G	f = 5MHz, open drain		3		Ω	
Dynamic Characteristics							
Input Capacitance	C _{ISS}	V _{GS} = 0V, V _{DS} = 400V, f = 100kHz		230		pF	
Output Capacitance	C _{OSS}			73			
Reverse Transfer Capacitance	C _{RSS}			0.5			
Effective Output Capacitance, Energy Related	C _{O_ER}			105			
Effective Output Capacitance, Time Related	C _{O_TR}	V _{GS} = 0V, V _{DS} = 0V to 400V		150		nC	
Output Charge	Q _{OSS}			60			
Turn-On Delay Time	t _{D_ON}	V _{GS} = 6V, V _{DS} = 400V, I _D = 16A, L = 318μH, R _{ON} = 10Ω, R _{OFF} = 2Ω, see Figure 22		3			ns
Turn-Off Delay Time	t _{D_OFF}			5			
Rise Time	t _R			4			
Fall Time	t _F			4			
Gate Charge Characteristics							
Total Gate Charge	Q _G	V _{GS} = 0V to 6V, V _{DS} = 400V, I _D = 8A		6.3		nC	
Gate-to-Source Charge	Q _{GS}			0.5			
Gate-to-Drain Charge	Q _{GD}			2.2			
Gate Plateau Voltage	V _{PLAT}	V _{DS} = 400V, I _D = 8A		2.2		V	
Reverse Conduction Characteristics							
Source-to-Drain Reverse Voltage	V _{SD}	V _{GS} = 0V, I _S = 8A		2.3		V	
Pulsed Current, Reverse	I _{S-PULSE}	V _{GS} = 6V, t _{PULSE} = 10μs			58	A	
Reverse Recovery Charge	Q _{RR}	V _{DS} = 400V, I _S = 8A		0		nC	
Reverse Recovery Time	t _{RR}			0		ns	
Peak Reverse Recovery Current	I _{RRM}			0		A	

TYPICAL PERFORMANCE CHARACTERISTICS

Figure 1 Typ. output characteristics

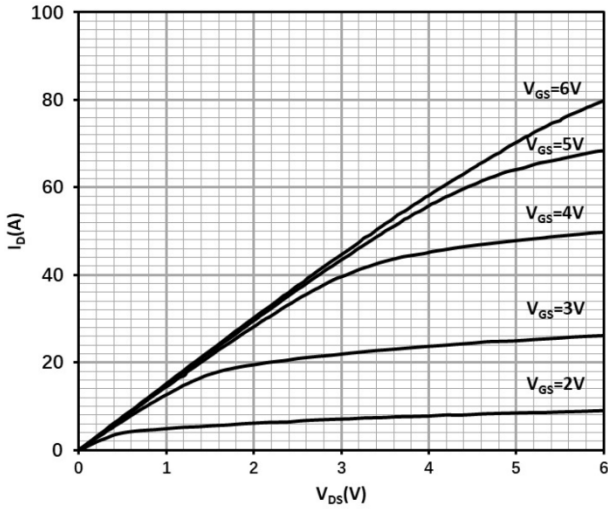

$I_D = f(V_{DS}, V_{GS}); T_j = 25\text{ °C}$

Figure 2 Typ. output characteristics

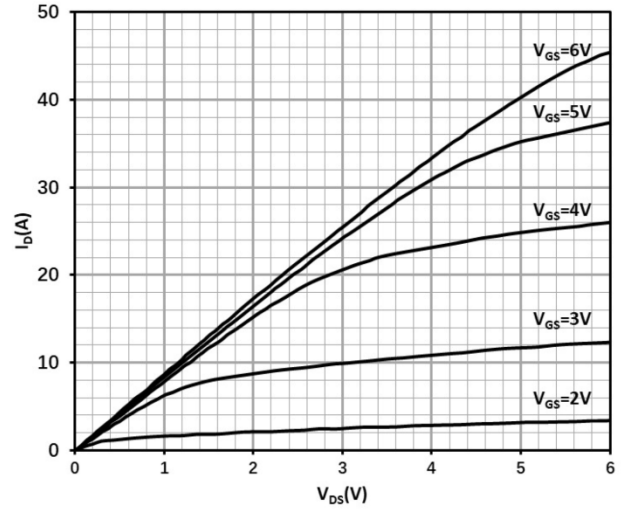

$I_D = f(V_{DS}, V_{GS}); T_j = 125\text{ °C}$

Figure 3 Typ. Drain-source on-state resistance

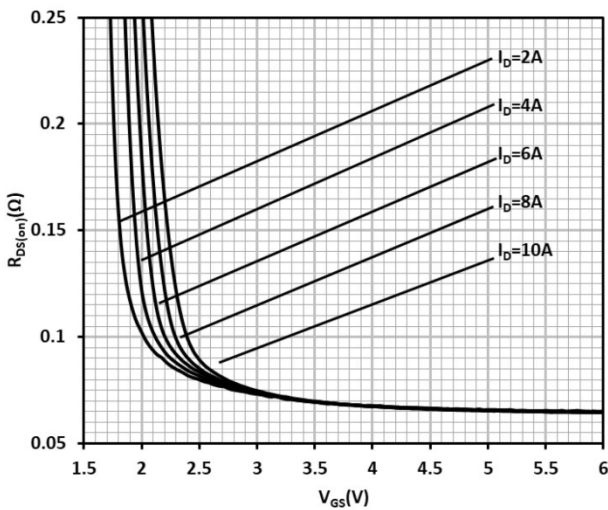

$R_{DS(on)} = f(I_D, V_{GS}); T_j = 25\text{ °C}$

Figure 4 Typ. Drain-source on-state resistance

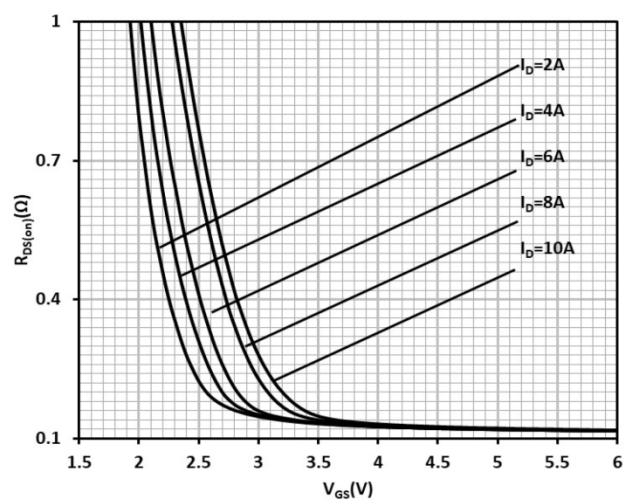

$R_{DS(on)} = f(I_D, V_{GS}); T_j = 125\text{ °C}$

TYPICAL PERFORMANCE CHARACTERISTICS (continued)

Figure 5 Typ. channel reverse characteristics

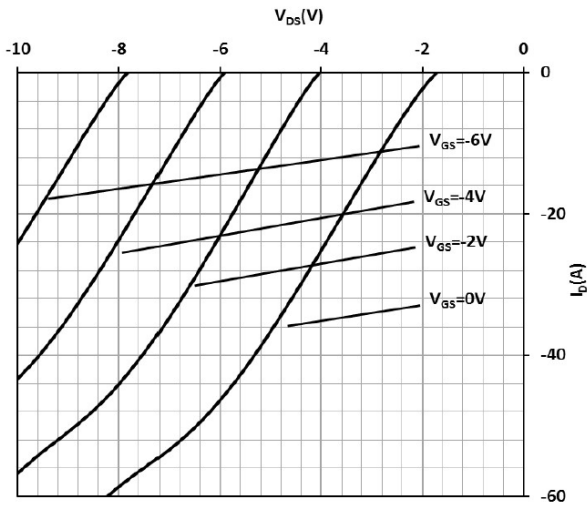

$I_D = f(V_{DS}, V_{GS}); T_j = 25\text{ }^\circ\text{C}$

Figure 6 Typ. channel reverse characteristics

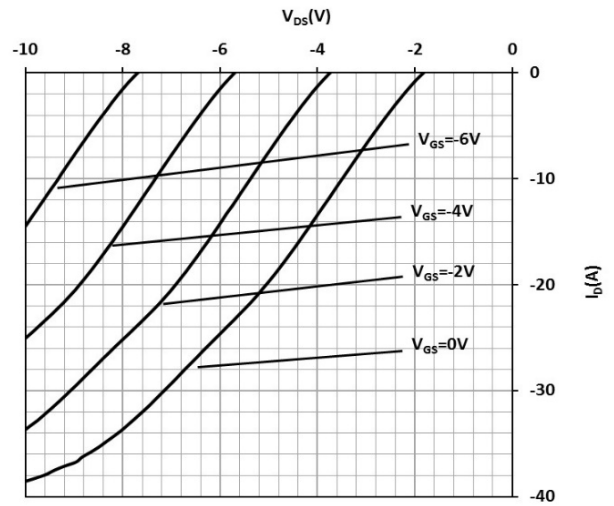

$I_D = f(V_{DS}, V_{GS}); T_j = 125\text{ }^\circ\text{C}$

Figure 7 Typ. channel reverse characteristics

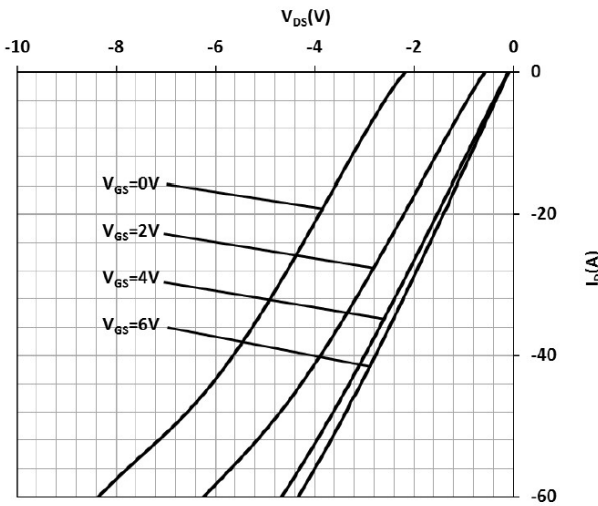

$I_D = f(V_{DS}, V_{GS}); T_j = 25\text{ }^\circ\text{C}$

Figure 8 Typ. channel reverse characteristics

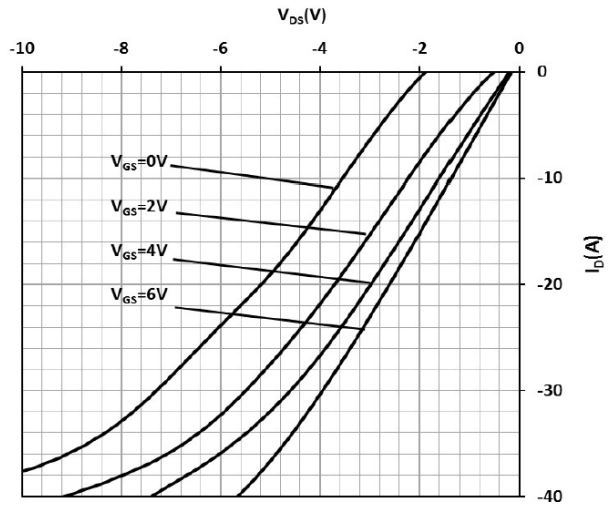

$I_D = f(V_{DS}, V_{GS}); T_j = 125\text{ }^\circ\text{C}$

TYPICAL PERFORMANCE CHARACTERISTICS (continued)

Figure 9 Typ. transfer characteristics

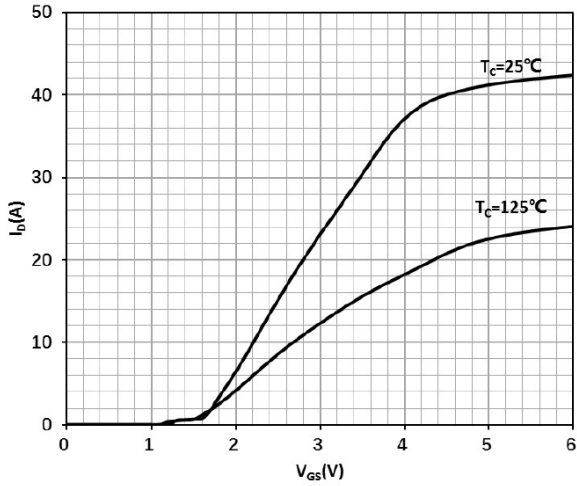

$I_D = f(V_{GS}); V_{DS} = 3 \text{ V}$

Figure 10 Typ. Gate-to-Source leakage

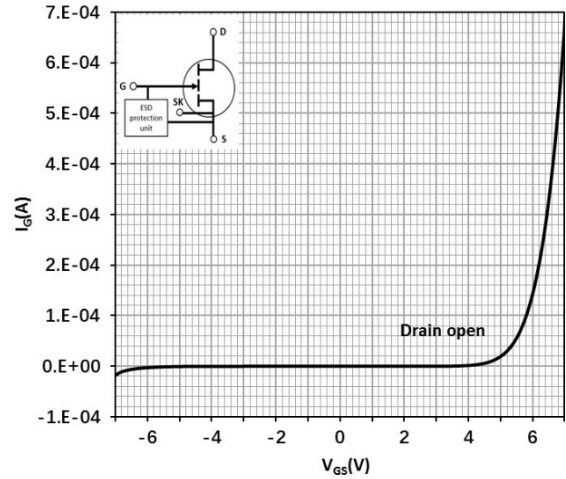

$I_G = f(V_{GS})$

Figure 11 Drain-source leakage characteristics

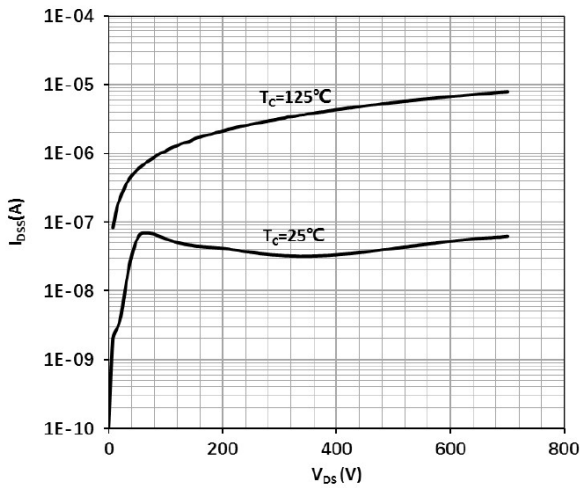

$I_{DSS} = f(V_{DS}); V_{GS} = 0 \text{ V}$

TYPICAL PERFORMANCE CHARACTERISTICS (continued)

Figure 12 Gate threshold voltage

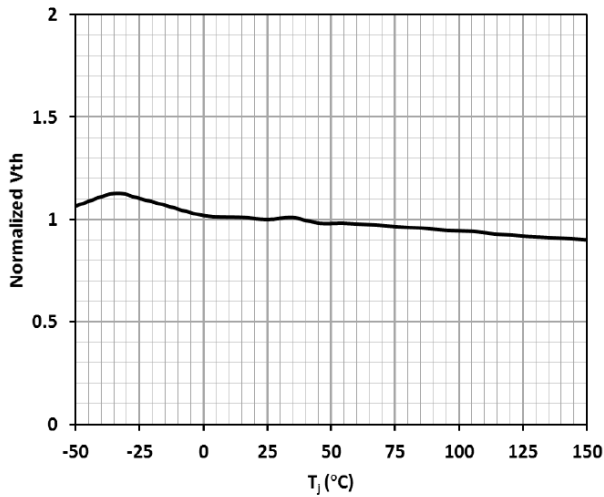

$V_{TH} = f(T_j)$; $V_{GS} = V_{DS}$; $I_D = 30.7 \text{ mA}$

Figure 13 Drain-source on-state resistance

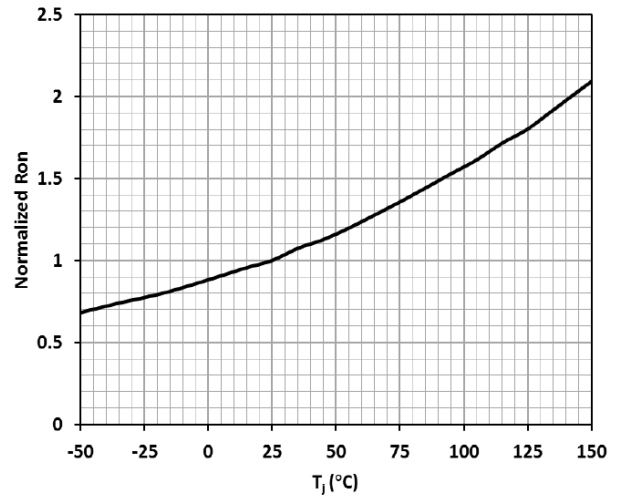

$R_{DS(on)} = f(T_j)$; $I_D = 8 \text{ A}$; $V_{GS} = 6 \text{ V}$

Figure 14 Power dissipation

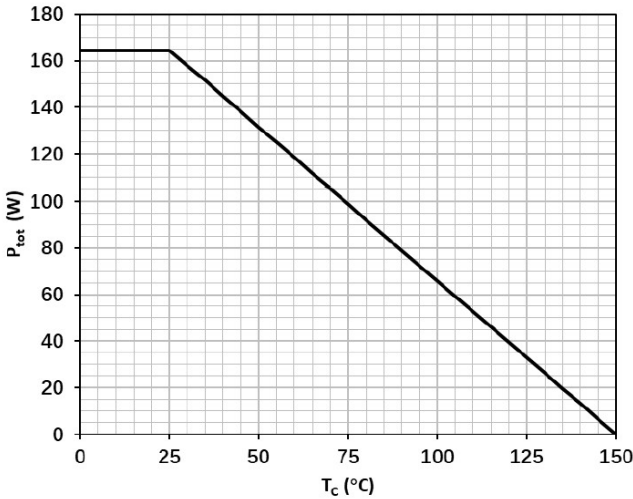

$P_{tot} = f(T_c)$

Figure 15 Max.transient thermal impedance

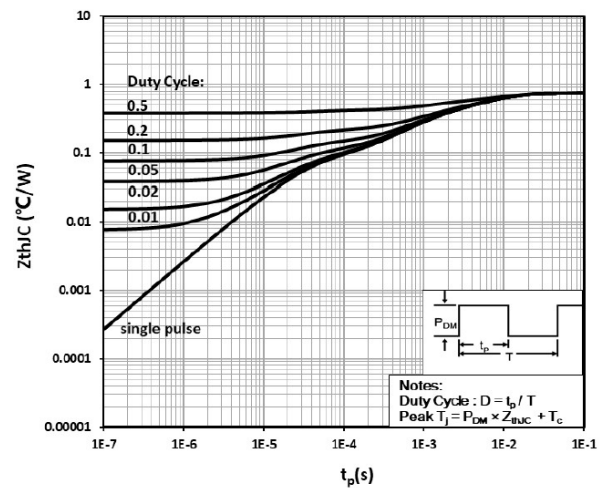

$Z_{thJC} = f(t_p, D)$

TYPICAL PERFORMANCE CHARACTERISTICS (continued)

Figure 16 Safe operating area

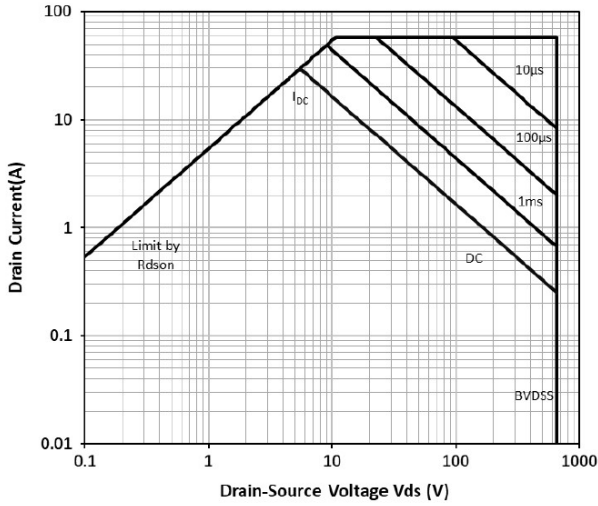

$I_D = f(V_{DS}); T_C = 25\text{ }^\circ\text{C}$

Figure 17 Safe operating area

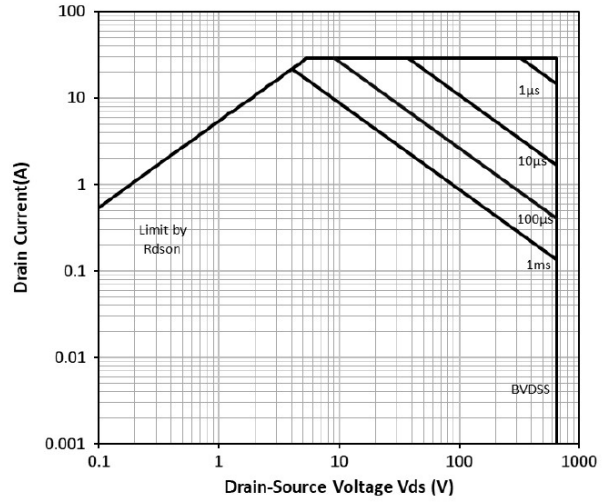

$I_D = f(V_{DS}); T_C = 125\text{ }^\circ\text{C}$

Figure 18 Typ. gate charge

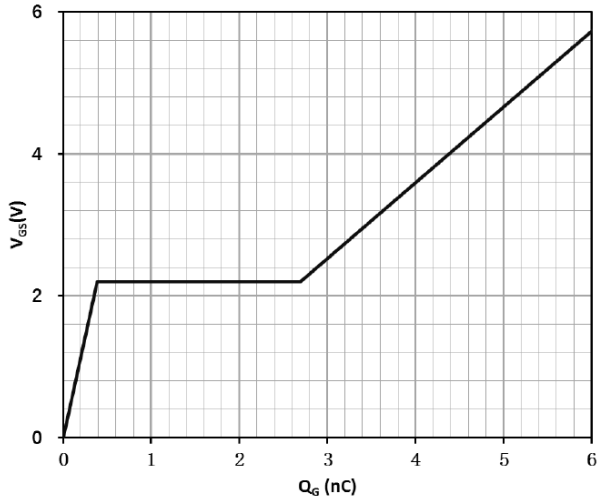

$V_{GS} = f(Q_G); V_{DCLINK} = 400\text{ V}; I_D = 8\text{ A}$

Figure 19 Typ. capacitances

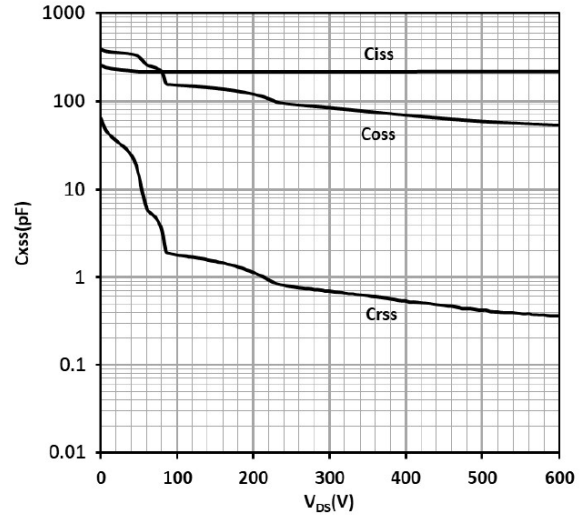

$C_{XSS} = f(V_{DS}); \text{Freq.} = 100\text{ kHz}$

TYPICAL PERFORMANCE CHARACTERISTICS (continued)

Figure 20 Typ. output charge

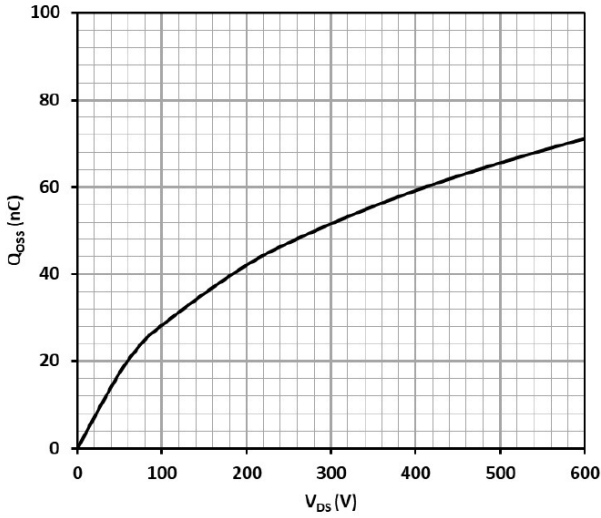

$Q_{oss} = f(V_{DS}); \text{Freq.} = 100 \text{ kHz}$

Figure 21 Typ. C_{oss} stored Energy

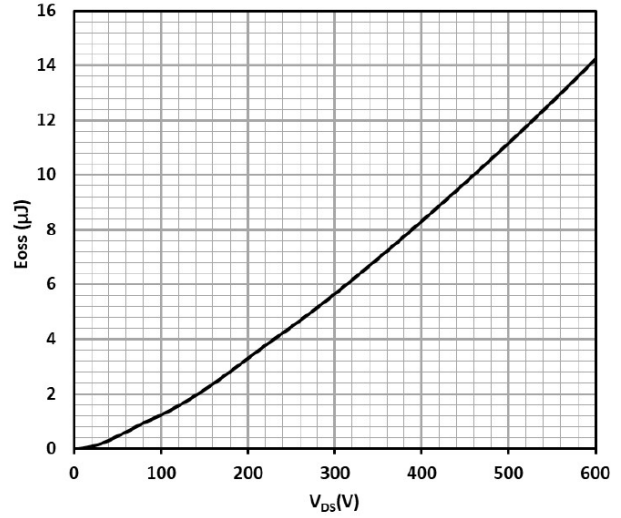

$E_{oss} = f(V_{DS}); \text{Freq.} = 100 \text{ kHz}$

Figure 22 Switching time test circuit

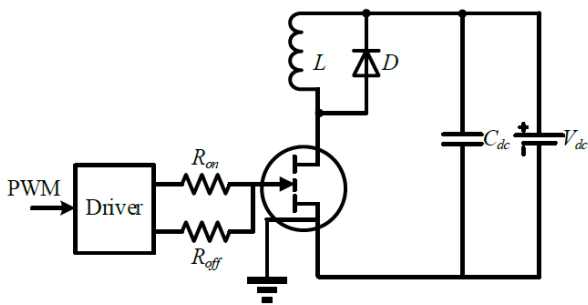

$V_{DS} = 400 \text{ V}, I_D = 16 \text{ A}, L = 318 \mu\text{H}, V_{GS} = 6 \text{ V},$
 $R_{on} = 10 \Omega, R_{off} = 2 \Omega$

Figure 23 Switching times waveform

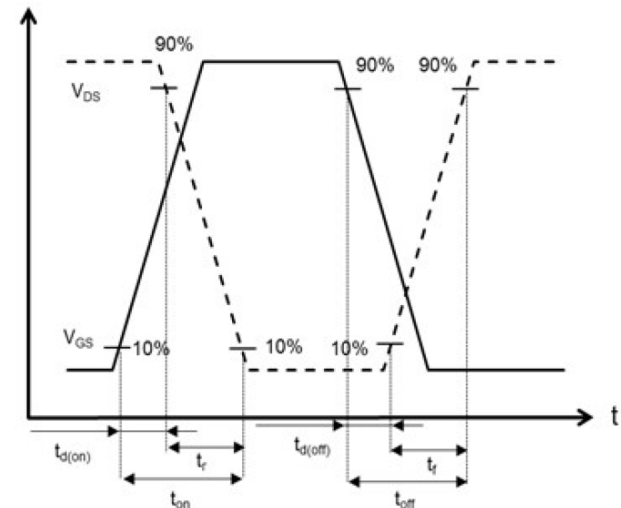

REVISION HISTORY

NOTE: Page numbers for previous revisions may differ from page numbers in the current version.

Changes from Original to REV.A (JUNE 2026)	Page
Changed from product preview to production data.....	All

PACKAGE OUTLINE DIMENSIONS

TOLL-8B

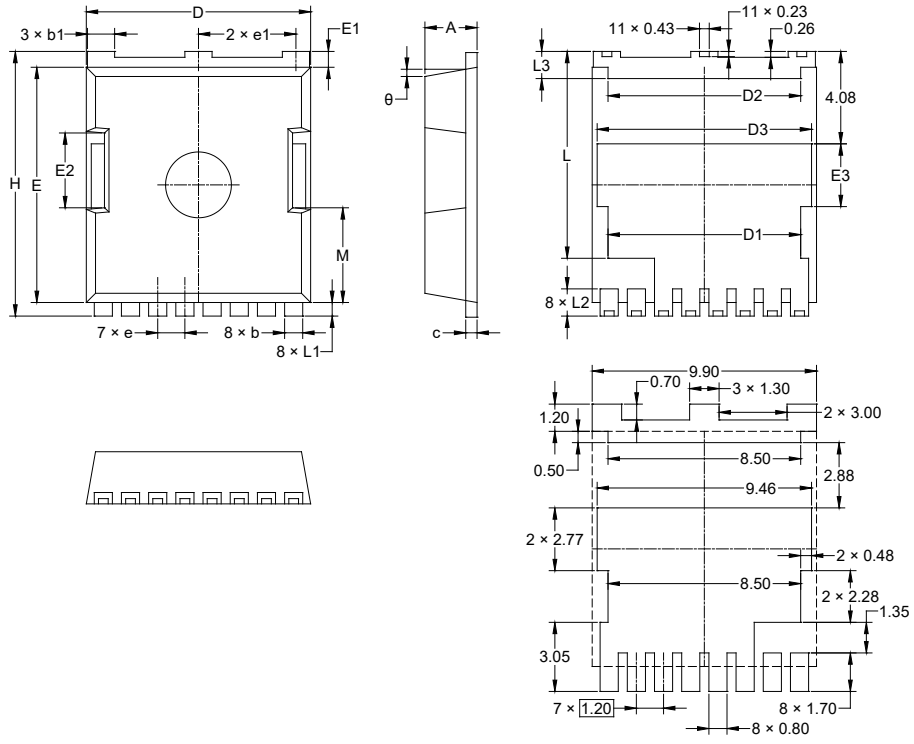

RECOMMENDED LAND PATTERN (Unit: mm)

Symbol	Dimensions In Millimeters		
	MIN	NOM	MAX
A	-	-	2.450
b	0.650	-	0.900
b1	1.100	-	1.300
c	0.400	-	0.600
D	9.700	-	10.100
D1	8.500 REF		
D2	8.500 REF		
D3	9.460 REF		
E	10.180	-	10.580
E1	0.500	-	0.900
E2	3.300 REF		
E3	2.770 REF		
e	1.200 BSC		
e1	4.300 BSC		
H	11.480	-	11.880
L	9.130 REF		
L1	0.500	-	0.700
L2	1.000	-	1.400
L3	1.000	-	1.400
M	4.180 REF		
θ	10° REF		

NOTE: This drawing is subject to change without notice.

TAPE AND REEL INFORMATION

REEL DIMENSIONS

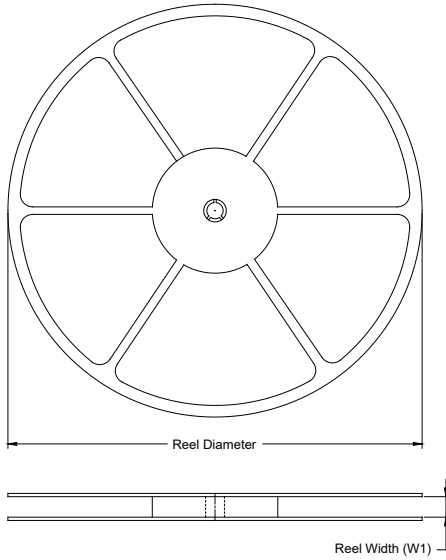

TAPE DIMENSIONS

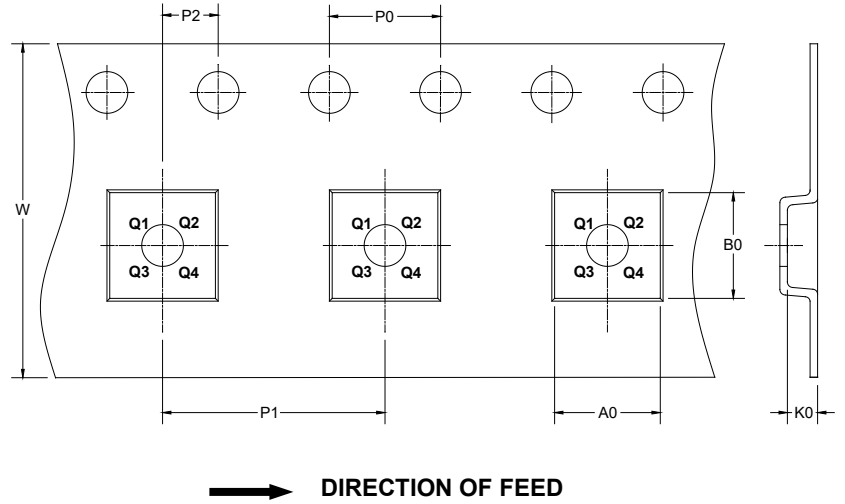

NOTE: The picture is only for reference. Please make the object as the standard.

KEY PARAMETER LIST OF TAPE AND REEL

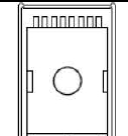
Package Type	Reel Diameter	Reel Width W1 (mm)	A0 (mm)	B0 (mm)	K0 (mm)	P0 (mm)	P1 (mm)	P2 (mm)	W (mm)	Pin1 Quadrant
TOLL-8B	13"	24.4	10.25	12.10	2.65	4.0	16.0	2.0	24.0	

DD0001

PACKAGE INFORMATION

CARTON BOX DIMENSIONS

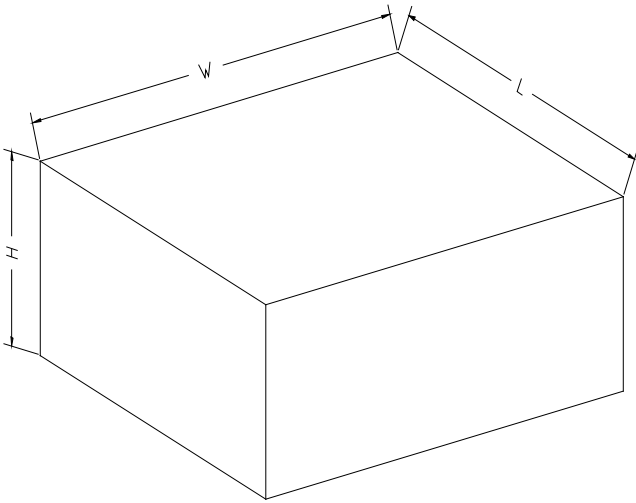

NOTE: The picture is only for reference. Please make the object as the standard.

KEY PARAMETER LIST OF CARTON BOX

Reel Type	Length (mm)	Width (mm)	Height (mm)	Pizza/Carton
13"	386	280	370	5

DD0002