

GENERAL DESCRIPTION

The 74HC373 is an 8-bit D-type transparent latch with 3-state outputs that is designed for 2.0V to 6.0V V_{CC} operation.

The device is provided with a latch enable (LE) input and an output enable (\overline{OE}) input. When LE is set high, data at the inputs gets access to the latches and the latches are transparent, the latch outputs will vary with corresponding data inputs. When LE is set low, the latches store data that appeared on the inputs for a setup time before the high-to-low transition of LE. When \overline{OE} is high, all outputs are in high-impedance state. \overline{OE} has no influence on the state of the latches.

The clamp diodes of inputs allow the use of current limiting resistors to connect inputs to the voltage exceeding supply voltage.

The 74HC373 is available in Green SOIC-20 and TSSOP-20 packages. It operates over a temperature range of -40°C to +125°C.

LOGIC DIAGRAM

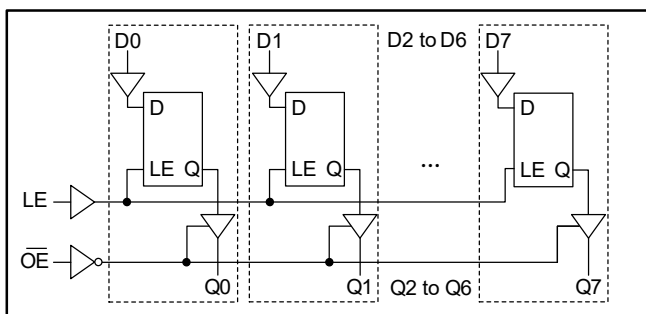

FEATURES

- **Wide Operating Voltage Range: 2.0V to 6.0V**
- **CMOS Low Power Consumption**
- **3-State Non-Inverting Outputs Suitable for Bus-Oriented Applications**
- **-40°C to +125°C Operating Temperature Range**
- **Available in Green SOIC-20 and TSSOP-20 Packages**

FUNCTION TABLE

CONTROL INPUT		INPUT	INTERNAL LATCHES	OUTPUT
\overline{OE}	LE	Dn		Qn
L	H	L	L	L
L	H	H	H	H
L	L	I	L	L
L	L	h	H	H
H	X	X	X	Z

H = High voltage level.

h = High voltage level one setup time before the high-to-low transition of LE.

L = Low voltage level.

I = Low voltage level one setup time before the high-to-low transition of LE.

Z = High-impedance state.

X = Don't care.

PACKAGE/ORDERING INFORMATION

MODEL	PACKAGE DESCRIPTION	SPECIFIED TEMPERATURE RANGE	ORDERING NUMBER	PACKAGE MARKING	PACKING OPTION
74HC373	SOIC-20	-40°C to +125°C	74HC373XS20G/TR	74HC373XS20 XXXXX	Tape and Reel, 1500
	TSSOP-20	-40°C to +125°C	74HC373XTS20G/TR	0MDXTS20 XXXXX	Tape and Reel, 4000

MARKING INFORMATION

NOTE: XXXXX = Date Code, Trace Code and Vendor Code.

XXXXX

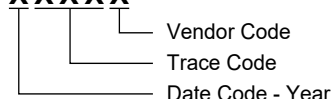

Green (RoHS & HSF): SG Micro Corp defines "Green" to mean Pb-Free (RoHS compatible) and free of halogen substances. If you have additional comments or questions, please contact your SGMICRO representative directly.

ABSOLUTE MAXIMUM RATINGS ⁽¹⁾

Supply Voltage Range, V_{CC}	-0.5V to 7.0V
Input Voltage Range, V_I ⁽²⁾	-0.5V to MIN(7.0V, $V_{CC} + 0.5V$)
Output Voltage Range, V_O ⁽²⁾	-0.5V to MIN(7.0V, $V_{CC} + 0.5V$)
Input Clamp Current, I_{IK} ($V_I < 0V$ or $V_I > V_{CC}$)	$\pm 20mA$
Output Clamp Current, I_{OK} ($V_O < 0V$ or $V_O > V_{CC}$)	$\pm 20mA$
Continuous Output Current, I_O ($V_O = 0V$ to V_{CC})	$\pm 35mA$
Continuous Current through V_{CC} or GND	$\pm 70mA$
Junction Temperature ⁽³⁾	+150°C
Storage Temperature Range	-65°C to +150°C
Lead Temperature (Soldering, 10s)	+260°C
ESD Susceptibility	
HBM	6000V
CDM	1000V

RECOMMENDED OPERATING CONDITIONS

Supply Voltage Range, V_{CC}	2.0V to 6.0V
Input Voltage Range, V_I	0V to V_{CC}
Output Voltage Range, V_O	0V to V_{CC}
Input Transition Rise or Fall Rate, $\Delta t/\Delta V$	
$V_{CC} = 2.0V$	625ns/V (MAX)
$V_{CC} = 4.5V$	139ns/V (MAX)
$V_{CC} = 5.5V$	83ns/V (MAX)
$V_{CC} = 6.0V$	83ns/V (MAX)
Operating Temperature Range	-40°C to +125°C

OVERSTRESS CAUTION

1. Stresses beyond those listed in Absolute Maximum Ratings may cause permanent damage to the device. Exposure to absolute maximum rating conditions for extended periods may affect reliability. Functional operation of the device at any conditions beyond those indicated in the Recommended Operating Conditions section is not implied.
2. The input and output voltage ratings may be exceeded if the input and output clamp current ratings are observed.
3. The performance capability of a high-performance integrated circuit in conjunction with its thermal environment can create junction temperatures which are detrimental to reliability.

ESD SENSITIVITY CAUTION

This integrated circuit can be damaged if ESD protections are not considered carefully. SGMICRO recommends that all integrated circuits be handled with appropriate precautions. Failure to observe proper handling and installation procedures can cause damage. ESD damage can range from subtle performance degradation to complete device failure. Precision integrated circuits may be more susceptible to damage because even small parametric changes could cause the device not to meet the published specifications.

DISCLAIMER

SG Micro Corp reserves the right to make any change in circuit design, or specifications without prior notice.

PIN CONFIGURATIONS

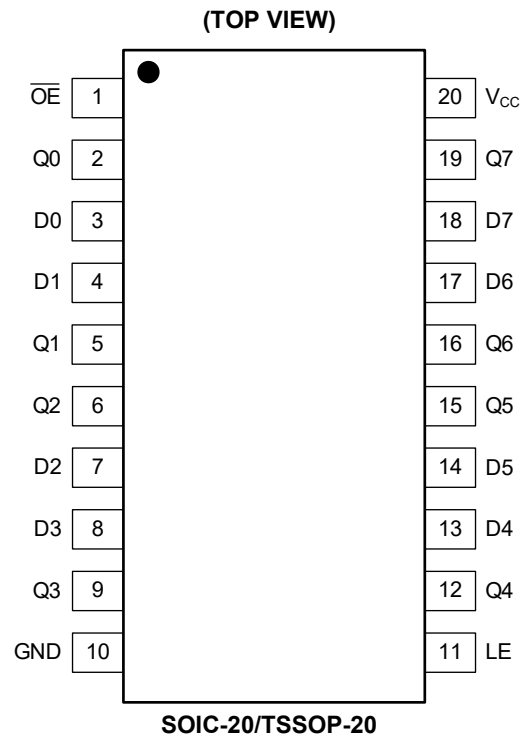

PIN DESCRIPTION

PIN	NAME	FUNCTION
1	\overline{OE}	Output Enable Input (Active-Low).
2, 5, 6, 9, 12, 15, 16, 19	Q0, Q1, Q2, Q3, Q4, Q5, Q6, Q7	Outputs.
3, 4, 7, 8, 13, 14, 17, 18	D0, D1, D2, D3, D4, D5, D6, D7	Data Inputs.
10	GND	Ground.
11	LE	Latch Enable Input (Active-High).
20	V _{CC}	Power Supply.

ELECTRICAL CHARACTERISTICS(Full = -40°C to +125°C, all typical values are measured at T_A = +25°C, unless otherwise noted.)

PARAMETER	SYMBOL	CONDITIONS	TEMP	MIN	TYP	MAX	UNITS
High-Level Input Voltage	V _{IH}	V _{CC} = 2.0V	Full	1.50			V
		V _{CC} = 4.5V	Full	3.15			
		V _{CC} = 5.5V	Full	3.85			
		V _{CC} = 6.0V	Full	4.20			
Low-Level Input Voltage	V _{IL}	V _{CC} = 2.0V	Full			0.50	V
		V _{CC} = 4.5V	Full			1.35	
		V _{CC} = 5.5V	Full			1.65	
		V _{CC} = 6.0V	Full			1.80	
High-Level Output Voltage	V _{OH}	V _{CC} = 2.0V, I _{OH} = -20μA	Full	1.95	1.995		V
		V _{CC} = 4.5V, I _{OH} = -20μA	Full	4.45	4.495		
		V _{CC} = 5.5V, I _{OH} = -20μA	Full	5.45	5.495		
		V _{CC} = 6.0V, I _{OH} = -20μA	Full	5.95	5.995		
		V _{CC} = 4.5V, I _{OH} = -6mA	Full	3.85	4.300		
		V _{CC} = 5.5V, I _{OH} = -7.8mA	Full	4.80	5.270		
		V _{CC} = 6.0V, I _{OH} = -7.8mA	Full	5.30	5.780		
Low-Level Output Voltage	V _{OL}	V _{CC} = 2.0V, I _{OL} = 20μA	Full		0.005	0.05	V
		V _{CC} = 4.5V, I _{OL} = 20μA	Full		0.005	0.05	
		V _{CC} = 5.5V, I _{OL} = 20μA	Full		0.005	0.05	
		V _{CC} = 6.0V, I _{OL} = 20μA	Full		0.005	0.05	
		V _{CC} = 4.5V, I _{OL} = 6mA	Full		0.170	0.40	
		V _{CC} = 5.5V, I _{OL} = 7.8mA	Full		0.210	0.40	
		V _{CC} = 6.0V, I _{OL} = 7.8mA	Full		0.210	0.40	
Input Leakage Current	I _I	V _{CC} = 6.0V, V _I = V _{CC} or GND	Full		±0.1	±1	μA
Off-State Output Current	I _{OZ}	V _{CC} = 6.0V, V _I = V _{IH} or V _{IL} , V _O = V _{CC} or GND	Full		±0.1	±5	μA
Supply Current	I _{CC}	V _{CC} = 6.0V, V _I = V _{CC} or GND, I _O = 0A	Full		0.1	5	μA
Input Capacitance	C _I		+25°C		3.5		pF

DYNAMIC CHARACTERISTICS(See Figure 1 for test circuit. Full = -40°C to +125°C, C_L = 50pF, all typical values are measured at T_A = +25°C, unless otherwise noted.)

PARAMETER	SYMBOL	CONDITIONS	TEMP	MIN ⁽¹⁾	TYP	MAX ⁽¹⁾	UNITS	
Propagation Delay ⁽²⁾	t _{PD}	Dn to Qn, see Figure 2	V _{CC} = 2.0V	Full	1	40	110	ns
			V _{CC} = 4.5V	Full	1	12	35	
			V _{CC} = 5.5V	Full	1	9	30	
			V _{CC} = 6.0V	Full	1	9	30	
		LE to Qn, see Figure 3	V _{CC} = 2.0V	Full	1	38	100	ns
			V _{CC} = 4.5V	Full	1	13	35	
			V _{CC} = 5.5V	Full	1	10	30	
			V _{CC} = 6.0V	Full	1	10	30	
Enable Time ⁽²⁾	t _{EN}	$\overline{\text{OE}}$ to Qn, see Figure 4	V _{CC} = 2.0V	Full	1	31	100	ns
			V _{CC} = 4.5V	Full	1	9	35	
			V _{CC} = 5.5V	Full	1	7	30	
			V _{CC} = 6.0V	Full	1	7	30	
Disable Time ⁽²⁾	t _{DIS}	$\overline{\text{OE}}$ to Qn, see Figure 4	V _{CC} = 2.0V	Full	1	15	30	ns
			V _{CC} = 4.5V	Full	1	8	25	
			V _{CC} = 5.5V	Full	1	8	25	
			V _{CC} = 6.0V	Full	1	8	25	
Transition Time ⁽²⁾	t _T	Qn, see Figure 2 and Figure 3	V _{CC} = 2.0V	Full	1	25	80	ns
			V _{CC} = 4.5V	Full	1	7	18	
			V _{CC} = 5.5V	Full	1	6	15	
			V _{CC} = 6.0V	Full	0.5	6	15	
Pulse Width	t _w	LE high, see Figure 3	V _{CC} = 2.0V	Full	80			ns
			V _{CC} = 4.5V	Full	16			
			V _{CC} = 5.5V	Full	14			
			V _{CC} = 6.0V	Full	14			
Setup Time	t _{SU}	Dn to LE, see Figure 5	V _{CC} = 2.0V	Full	40			ns
			V _{CC} = 4.5V	Full	18			
			V _{CC} = 5.5V	Full	15			
			V _{CC} = 6.0V	Full	15			
Hold Time	t _H	Dn to LE, see Figure 5	V _{CC} = 2.0V	Full	5			ns
			V _{CC} = 4.5V	Full	5			
			V _{CC} = 5.5V	Full	5			
			V _{CC} = 6.0V	Full	5			
Power Dissipation Capacitance ⁽³⁾	C _{PD}	Per latch, V _I = GND to V _{CC}	+25°C		8.5		pF	

NOTES:

- Specified by design and characterization, not production tested.
- t_{PD} is the same as t_{PLH} and t_{PHL}. t_{DIS} is the same as t_{PLZ} and t_{PHZ}. t_{EN} is the same as t_{PZL} and t_{PZH}. t_T is the same as t_{THL} and t_{TLH}.
- C_{PD} is used to determine the dynamic power dissipation (P_D in μW).

$$P_D = C_{PD} \times V_{CC}^2 \times f_i \times N + \sum(C_L \times V_{CC}^2 \times f_o)$$

where:

f_i = Input frequency in MHz.f_o = Output frequency in MHz.C_L = Output load capacitance in pF.V_{CC} = Supply voltage in Volts.

N = Number of inputs switching.

Σ(C_L × V_{CC}² × f_o) = Sum of the outputs.

TEST CIRCUIT

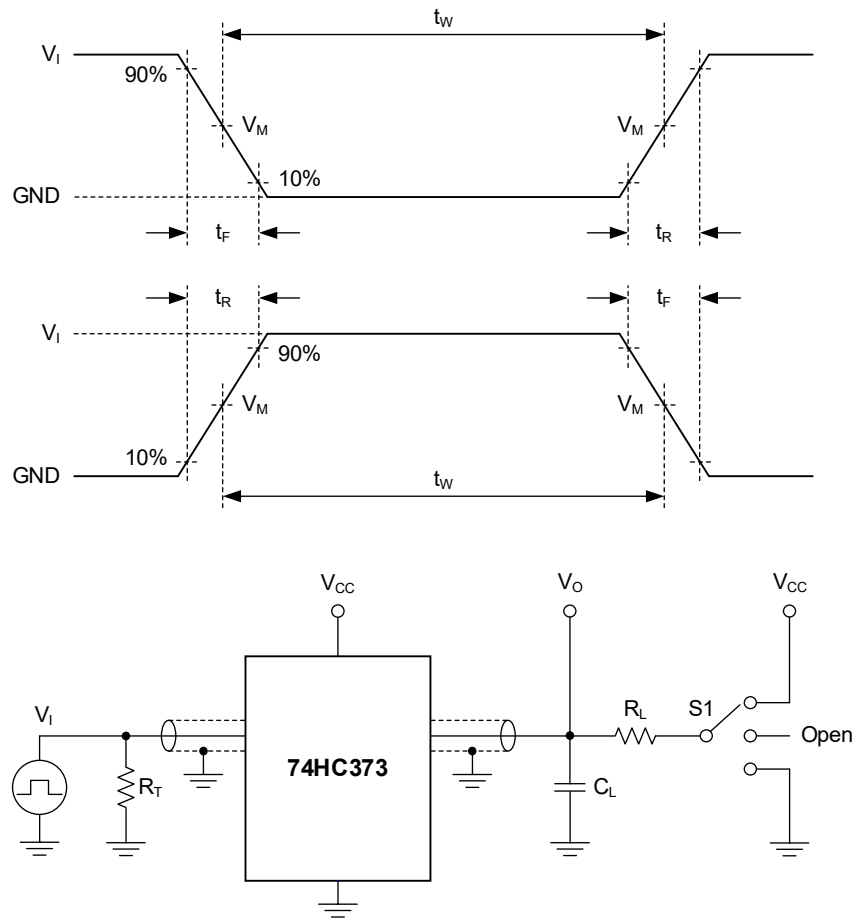

Test conditions are given in Table 1.

Definitions for test circuit:

R_L : Load resistance.

C_L : Load capacitance (includes jig and probe).

R_T : Termination resistance (equals to output impedance Z_O of the pulse generator).

S1: Test selection switch.

Figure 1. Test Circuit for Measuring Switching Times

Table 1. Test Conditions

SUPPLY VOLTAGE	INPUT		LOAD		S1 POSITION		
V_{CC}	V_I	t_R, t_F	C_L	R_L	t_{PLH}, t_{PHL}	t_{PLZ}, t_{PZL}	t_{PHZ}, t_{PZH}
2.0V to 6.0V	V_{CC}	$\leq 6.0ns$	50pF	1k Ω	Open	V_{CC}	GND

WAVEFORMS

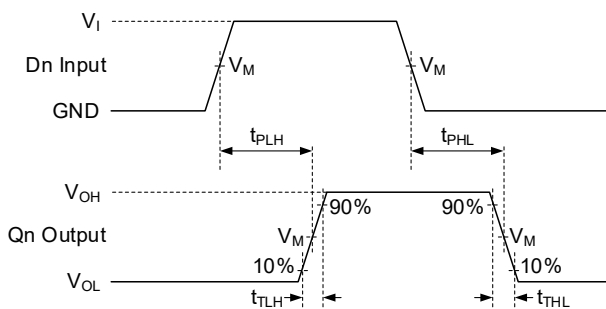

Test conditions are given in Table 1.

Measurement points are given in Table 2.

Logic levels: V_{OL} and V_{OH} are typical output voltage levels that occur with the output load.

Figure 2. Data Input Dn to Output Qn Propagation Delays and Transition Times

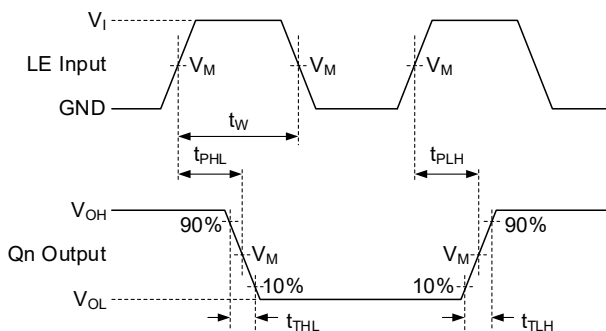

Test conditions are given in Table 1.

Measurement points are given in Table 2.

Logic levels: V_{OL} and V_{OH} are typical output voltage levels that occur with the output load.

Figure 3. Latch Enable Input LE to Output Qn Propagation Delays, Pulse Width and Transition Times

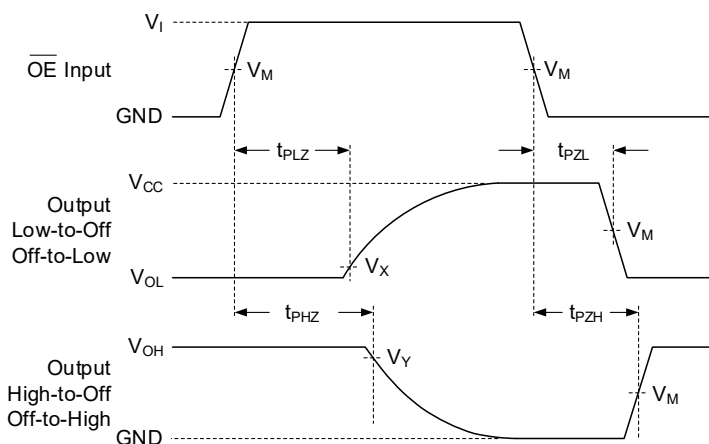

Test conditions are given in Table 1.

Measurement points are given in Table 2.

Logic levels: V_{OL} and V_{OH} are typical output voltage levels that occur with the output load.

Figure 4. Enable and Disable Times

WAVEFORMS (continued)

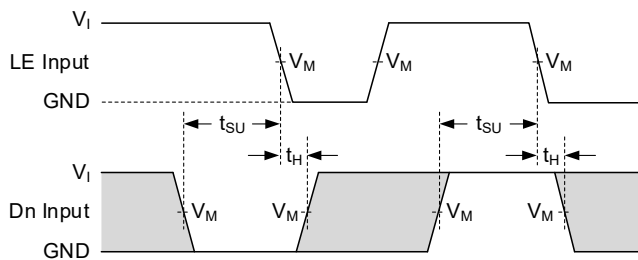

Test conditions are given in Table 1.

Measurement points are given in Table 2.

The shaded areas indicate when the input is permitted to change for predictable output performance.

Figure 5. Data Setup and Hold Times

Table 2. Measurement Points

SUPPLY VOLTAGE	INPUT		OUTPUT		
V _{CC}	V _I	V _M ⁽¹⁾	V _M	V _X	V _Y
2.0V to 6.0V	V _{CC}	0.5 × V _{CC}	0.5 × V _{CC}	0.1 × V _{CC}	0.9 × V _{CC}

NOTE:

1. The measurement points should be V_{IH} or V_{IL} when the input rising or falling time exceeds 6.0ns.

REVISION HISTORY

NOTE: Page numbers for previous revisions may differ from page numbers in the current version.

JANUARY 2026 – REV.A to REV.A.1	Page
Updated Supply Voltage Range.....	All
Changes from Original (NOVEMBER 2023) to REV.A	Page
Changed from product preview to production data.....	All

PACKAGE OUTLINE DIMENSIONS

SOIC-20

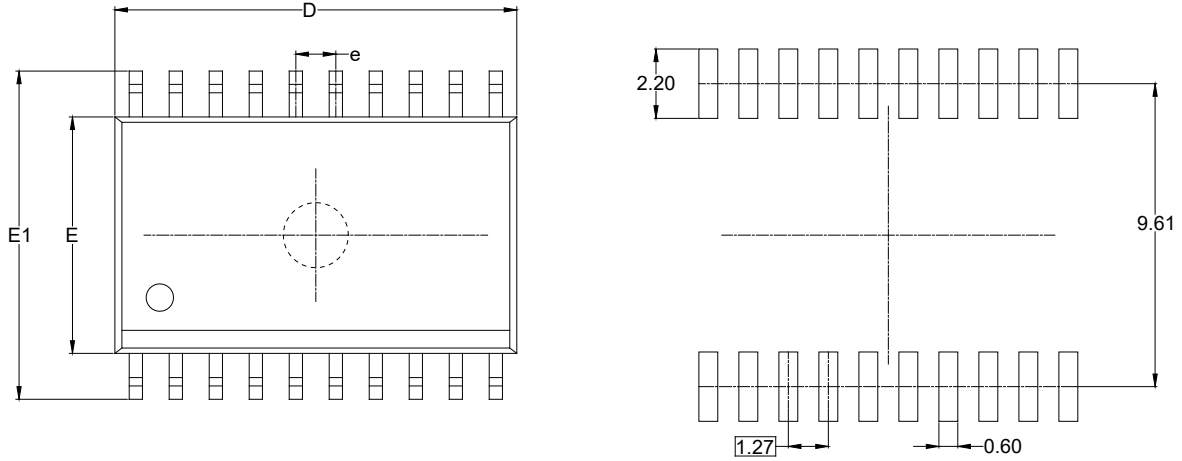

RECOMMENDED LAND PATTERN (Unit: mm)

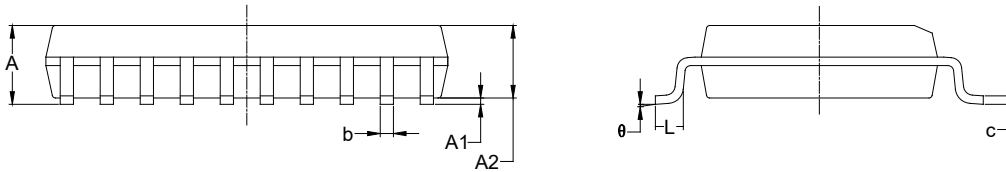

Symbol	Dimensions In Millimeters		Dimensions In Inches	
	MIN	MAX	MIN	MAX
A	2.350	2.650	0.093	0.104
A1	0.100	0.300	0.004	0.012
A2	2.100	2.500	0.083	0.098
b	0.330	0.510	0.013	0.020
c	0.204	0.330	0.008	0.013
D	12.520	13.000	0.493	0.512
E	7.400	7.600	0.291	0.299
E1	10.210	10.610	0.402	0.418
e	1.27 BSC		0.050 BSC	
L	0.400	1.270	0.016	0.050
θ	0°	8°	0°	8°

NOTES:

1. Body dimensions do not include mode flash or protrusion.
2. This drawing is subject to change without notice.

PACKAGE OUTLINE DIMENSIONS

TSSOP-20

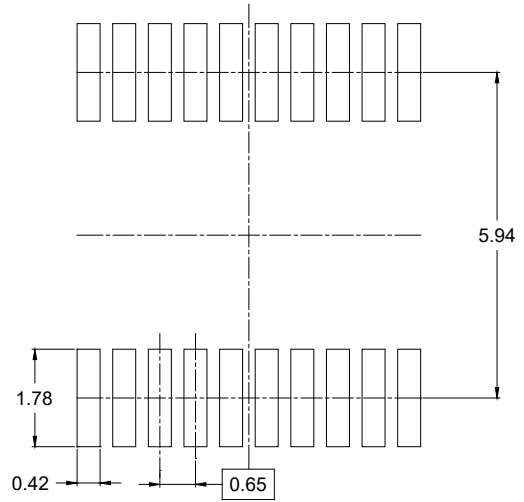
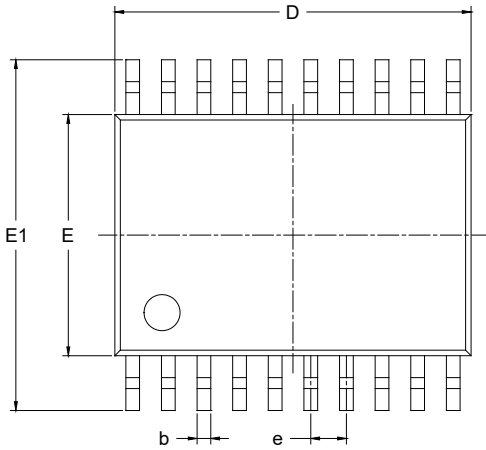

RECOMMENDED LAND PATTERN (Unit: mm)

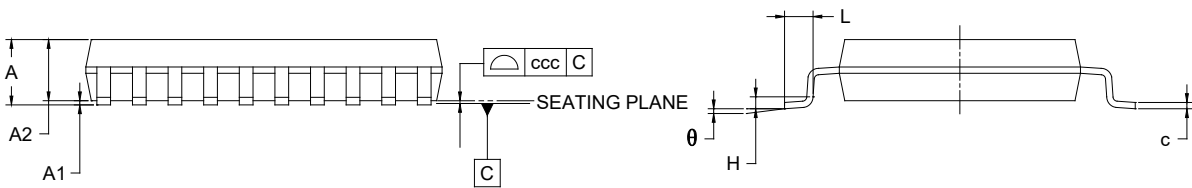

Symbol	Dimensions In Millimeters		
	MIN	NOM	MAX
A	-	-	1.200
A1	0.050	-	0.150
A2	0.800	-	1.050
b	0.190	-	0.300
c	0.090	-	0.200
D	6.400	-	6.600
E	4.300	-	4.500
E1	6.200	-	6.600
e	0.650 BSC		
L	0.450	-	0.750
H	0.250 TYP		
θ	0°	-	8°
ccc	0.100		

NOTES:

1. Body dimensions do not include mode flash or protrusion.
2. This drawing is subject to change without notice.
3. Reference JEDEC MO-153.

TAPE AND REEL INFORMATION

REEL DIMENSIONS

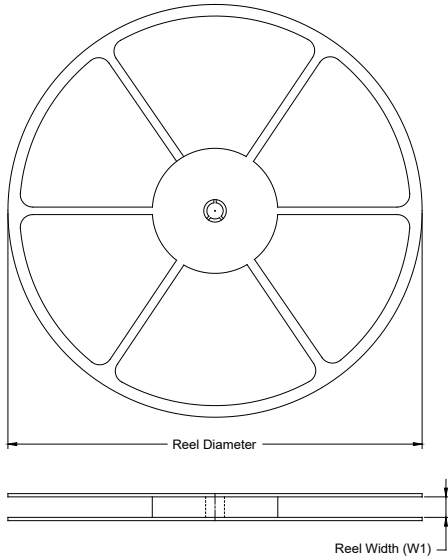

TAPE DIMENSIONS

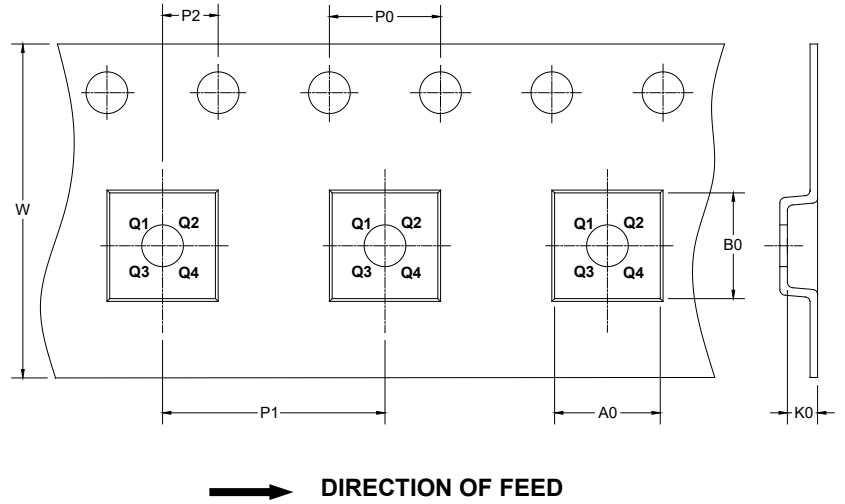

NOTE: The picture is only for reference. Please make the object as the standard.

KEY PARAMETER LIST OF TAPE AND REEL

Package Type	Reel Diameter	Reel Width W1 (mm)	A0 (mm)	B0 (mm)	K0 (mm)	P0 (mm)	P1 (mm)	P2 (mm)	W (mm)	Pin1 Quadrant
SOIC-20	13"	24.4	10.90	13.30	3.00	4.0	12.0	2.0	24.0	Q1
TSSOP-20	13"	16.4	6.80	6.90	1.50	4.0	8.0	2.0	16.0	Q1

DR00001

PACKAGE INFORMATION

CARTON BOX DIMENSIONS

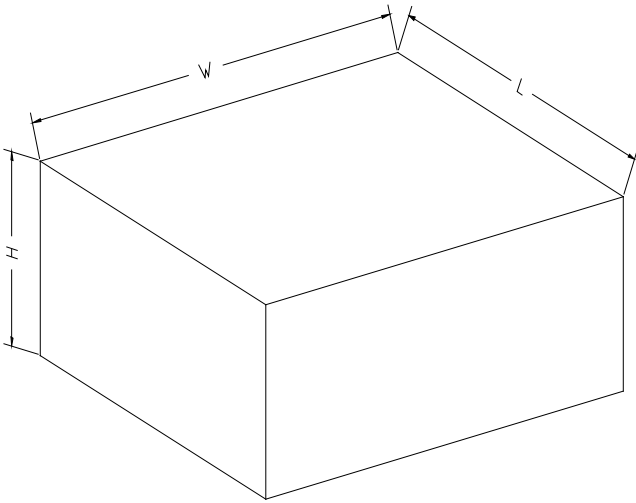

NOTE: The picture is only for reference. Please make the object as the standard.

KEY PARAMETER LIST OF CARTON BOX

Reel Type	Length (mm)	Width (mm)	Height (mm)	Pizza/Carton
13"	386	280	370	5

DD0002