

### GENERAL DESCRIPTION

The SGM8192-2 current-sense differential amplifier delivers a cost-effective solution for precision current measurement across industrial, medical, telecom and computing applications. The device senses the voltage across a current-sense resistor at common mode voltage from -0.2V to 30V, functionality independent of the supply voltage. The SGM8192-2A2 integrates a matched resistor gain network with a fixed gain of 50V/V. This precision-matched architecture minimizes gain error and reduces temperature drift.

The SGM8192-2 operates from a single 2.7V to 5.5V power supply and draws a typical supply current of 400µA.

The SGM8192-2 is available in Green MSOP-8 and TDFN-2×2-8AL packages. It is specified over the extended -40°C to +125°C temperature range.

### FEATURES

- Power Supply Range: 2.7V to 5.5V
- Common Mode Range: -0.2V to 30V
- High Bandwidth: 270kHz (TYP)
- Output Slew Rate: 2V/µs (TYP)
- SGM8192-2A2 Gain: 50V/V
- Gain Error: ±0.015% (TYP)
- Offset Drift: 0.2µV/°C (TYP)
- Input Offset Voltage:
  - ♦ ±15µV (TYP) at  $V_{CM} = 0V$
  - ♦ ±30µV (TYP) at  $V_{CM} = 12V$
- Quiescent Current: 400µA (TYP)
- -40°C to +125°C Operating Temperature Range
- Available in Green MSOP-8 and TDFN-2×2-8AL Packages

### APPLICATIONS

Industrial Equipment  
 Medical Equipment  
 Telecom Equipment  
 Computing: Notebook, Server

### TYPICAL APPLICATION

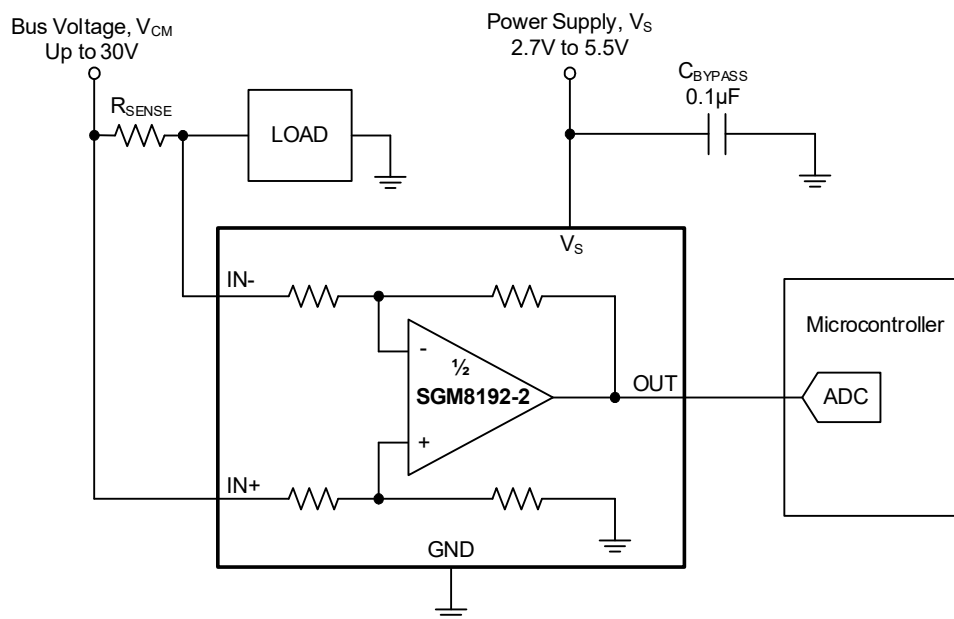

Figure 1. Typical Application Circuit

**PACKAGE/ORDERING INFORMATION**

MODEL	PACKAGE DESCRIPTION	SPECIFIED TEMPERATURE RANGE	ORDERING NUMBER	PACKAGE MARKING	PACKING OPTION
SGM8192-2A2	MSOP-8	-40°C to +125°C	SGM8192-2A2XMS8G/TR	SGM2M0 XMS8 XXXXX	Tape and Reel, 4000
	TDFN-2×2-8AL	-40°C to +125°C	SGM8192-2A2XTDE8G/TR	2M1 XXXX	Tape and Reel, 3000

**MARKING INFORMATION**

NOTE: XXXXX = Date Code, Trace Code and Vendor Code. XXXX = Date Code, Trace Code and Vendor Code.

**MSOP-8**

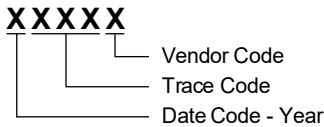

**TDFN-2×2-8AL**

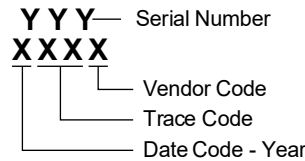

Green (RoHS & HSF): SG Micro Corp defines "Green" to mean Pb-Free (RoHS compatible) and free of halogen substances. If you have additional comments or questions, please contact your SGMICRO representative directly.

**ABSOLUTE MAXIMUM RATINGS**

Supply Voltage, $V_s$ .....	6.0V
Analog Inputs, $IN+$ , $IN-$ <sup>(1)</sup>	
Differential ( $V_{IN+}$ - $V_{IN-}$ ).....	-32V to 32V
Common Mode <sup>(2)</sup> .....	GND - 0.3V to 32V
Output Voltage.....	GND - 0.3V to $V_s$ + 0.3V
Maximum Output Current, $I_{OUT}$ .....	±25mA
Package Thermal Resistance	
MSOP-8, $\theta_{JA}$ .....	142.6°C/W
MSOP-8, $\theta_{JB}$ .....	82.9°C/W
MSOP-8, $\theta_{JC}$ .....	52°C/W
TDFN-2×2-8AL, $\theta_{JA}$ .....	83.5°C/W
TDFN-2×2-8AL, $\theta_{JB}$ .....	49.6°C/W
TDFN-2×2-8AL, $\theta_{JC}$ (TOP).....	81.5°C/W
TDFN-2×2-8AL, $\theta_{JC}$ (BOT).....	38.5°C/W
Junction Temperature.....	+150°C
Storage Temperature Range.....	-65°C to +150°C
Lead Temperature (Soldering, 10s).....	+260°C
ESD Susceptibility <sup>(3)</sup> <sup>(4)</sup>	
HBM.....	±4000V
CDM.....	±1000V

**NOTES:**

- $V_{IN+}$  and  $V_{IN-}$  are the voltages at the pins  $IN+$  and  $IN-$ .
- The input voltage at any pin may exceed the indicated voltage if the current at that pin is limited to 5mA.
- For human body model (HBM), all pins comply with ANSI/ESDA/JEDEC JS-001 specifications.
- For charged device model (CDM), all pins comply with ANSI/ESDA/JEDEC JS-002 specifications.

**RECOMMENDED OPERATING CONDITIONS**

Input Common Mode Voltage ( $IN+$ and $IN-$ ), $V_{CM}$	-0.2V to 30V, 12V (TYP)
Operating Supply Voltage, $V_s$ .....	2.7V to 5.5V, 5V (TYP)
Operating Temperature Range.....	-40°C to +125°C

**OVERSTRESS CAUTION**

Stresses beyond those listed in Absolute Maximum Ratings may cause permanent damage to the device. Exposure to absolute maximum rating conditions for extended periods may affect reliability. Functional operation of the device at any conditions beyond those indicated in the Recommended Operating Conditions section is not implied.

**ESD SENSITIVITY CAUTION**

This integrated circuit can be damaged if ESD protections are not considered carefully. SGMICRO recommends that all integrated circuits be handled with appropriate precautions. Failure to observe proper handling and installation procedures can cause damage. ESD damage can range from subtle performance degradation to complete device failure. Precision integrated circuits may be more susceptible to damage because even small parametric changes could cause the device not to meet the published specifications.

**DISCLAIMER**

SG Micro Corp reserves the right to make any change in circuit design, or specifications without prior notice.

PIN CONFIGURATIONS

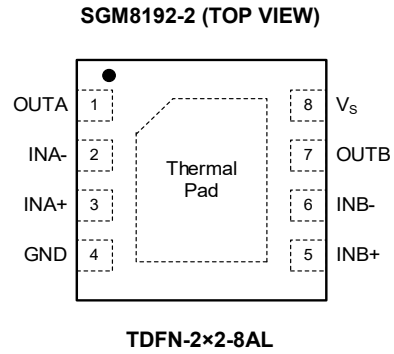
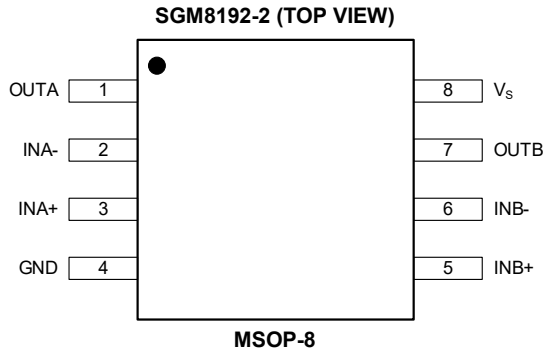

PIN DESCRIPTION

PIN		NAME	FUNCTION
MSOP-8	TDFN-2x2-8AL		
1	1	OUTA	Output of Current-Sense Amplifier A.
2	2	INA-	Inverting Input of Current-Sense Amplifier A. For high-side applications, please put this pin at load side of amplifier A sense resistor. For low-side applications, please put this pin at ground side of amplifier A sense resistor.
3	3	INA+	Non-Inverting Input of Current-Sense Amplifier A. For high-side applications, please put this pin at bus-voltage side of amplifier A sense resistor. For low-side applications, please put this pin at load side of amplifier A sense resistor.
4	4	GND	Ground.
5	5	INB+	Non-Inverting Input of Current-Sense Amplifier B. For high-side applications, please put this pin at bus-voltage side of amplifier B sense resistor. For low-side applications, please put this pin at load side of amplifier B sense resistor.
6	6	INB-	Inverting Input of Current-Sense Amplifier B. For high-side applications, please put this pin at load side of amplifier B sense resistor. For low-side applications, please put this pin at ground side of amplifier B sense resistor.
7	7	OUTB	Output of Current-Sense Amplifier B.
8	8	V <sub>s</sub>	Power Supply.
—	Thermal Pad	Thermal Pad	Only for TDFN-2x2-8AL Package. Thermal pad can be left floating or connected to GND.

**ELECTRICAL CHARACTERISTICS**(V<sub>S</sub> = 5V, V<sub>IN+</sub> = 12V, V<sub>SENSE</sub> = V<sub>IN+</sub> - V<sub>IN-</sub>, Full = -40°C to +125°C, typical values are at T<sub>A</sub> = +25°C, unless otherwise noted.)

PARAMETER	SYMBOL	CONDITIONS	TEMP	MIN	TYP	MAX	UNITS
<b>Input Characteristics</b>							
Input Offset Voltage <sup>(1)</sup> , RTI <sup>(2)</sup>	V <sub>OS</sub>	V <sub>CM</sub> = 12V	+25°C		±30	±180	μV
		V <sub>CM</sub> = 0V	+25°C		±15	±75	
Input Offset Voltage Drift, RTI	ΔV <sub>OS</sub> /ΔT		Full		0.2	0.5	μV/°C
Input Bias Current	I <sub>B</sub>	V <sub>SENSE</sub> = 0mV, V <sub>IN+</sub> = 0V	+25°C		0.1		μA
		V <sub>SENSE</sub> = 0mV	+25°C		50		
Input Offset Current	I <sub>OS</sub>	V <sub>SENSE</sub> = 0mV	+25°C		±0.4		μA
Common Mode Rejection Ratio, RTI <sup>(2)</sup>	CMRR	V <sub>IN+</sub> = 0V to 30V, V <sub>SENSE</sub> = 10mV	Full	94	110		dB
<b>Output Characteristics</b>							
Gain	G		+25°C		50		V/V
Gain Error	GE	V <sub>OUT</sub> = 0.5V to (V <sub>S</sub> - 0.5V)	Full		±0.015	±0.2	%
Gain Error Drift			Full		0.8	2	ppm/°C
Nonlinearity Error		V <sub>OUT</sub> = 0.5V to (V <sub>S</sub> - 0.5V)	+25°C		±0.01		%
Maximum Capacitive Load		No sustained oscillation	+25°C		1		nF
<b>Voltage Output</b>							
Swing to V <sub>S</sub> Power Supply Rail <sup>(3)</sup>	V <sub>SP</sub>	R <sub>L</sub> = 10kΩ to GND	Full	V <sub>S</sub> - 0.03	V <sub>S</sub> - 0.015		V
Swing to GND <sup>(3)</sup>	V <sub>SN</sub>	R <sub>L</sub> = 10kΩ to GND	Full		V <sub>GND</sub> +0.001	V <sub>GND</sub> +0.005	V
<b>Frequency Response</b>							
Bandwidth	BW	C <sub>LOAD</sub> = 10pF	+25°C		270		kHz
Slew Rate	SR		+25°C		2		V/μs
<b>Noise, RTI <sup>(2)</sup></b>							
Voltage Noise Density			+25°C		40		nV/√Hz
<b>Power Supply</b>							
Quiescent Current	I <sub>Q</sub>	V <sub>SENSE</sub> = 10mV	+25°C		400	550	μA
			Full			580	
Power Supply Rejection Ratio, RTI <sup>(2)</sup>	PSRR	V <sub>S</sub> = 2.7V to 5.5V, V <sub>SENSE</sub> = 10mV	+25°C		±2	±8	μV/V

## NOTES:

1. The input offset voltage is measured at linear extrapolation to V<sub>SENSE</sub> = 0mV with V<sub>SENSE</sub> = 10% to 90% of full-scale-range.
2. RTI = Referred-to-input.
3. Test swing specifications under overdriven input conditions.

FUNCTIONAL BLOCK DIAGRAM

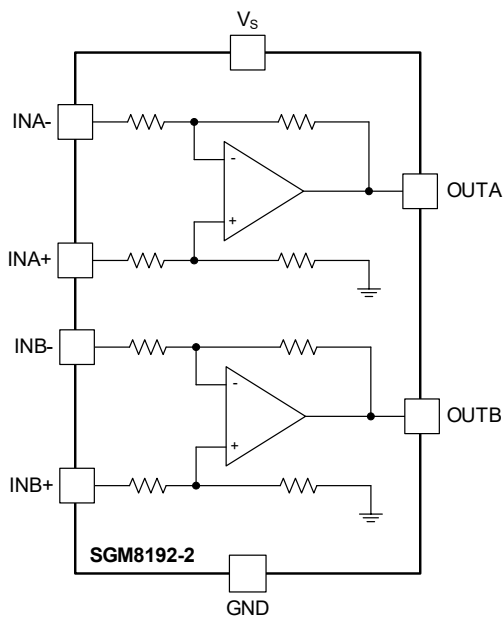
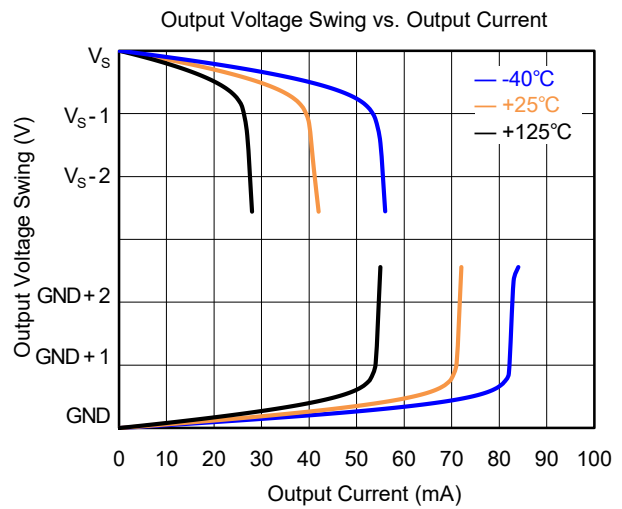
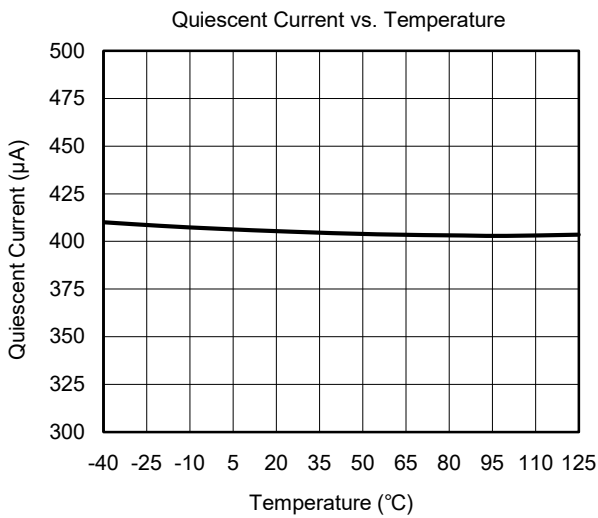
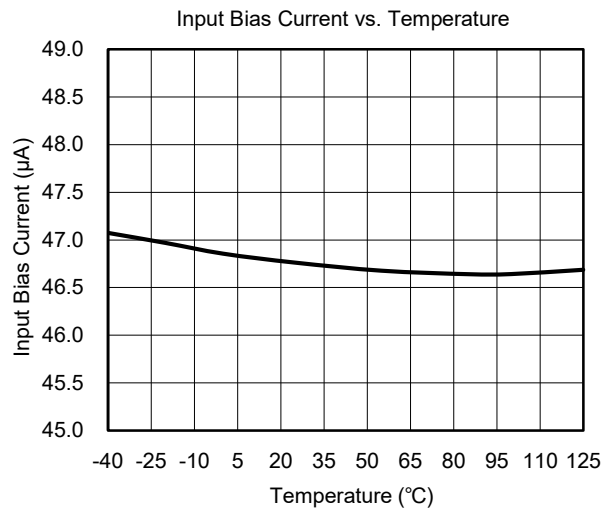
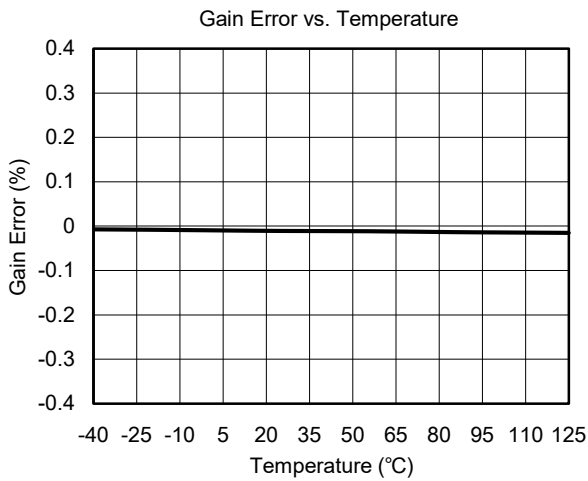
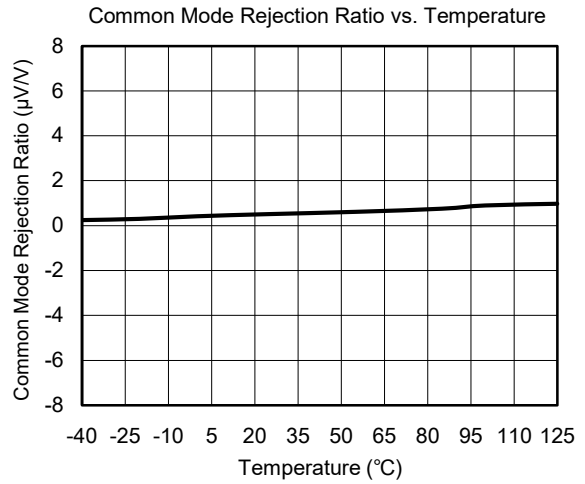
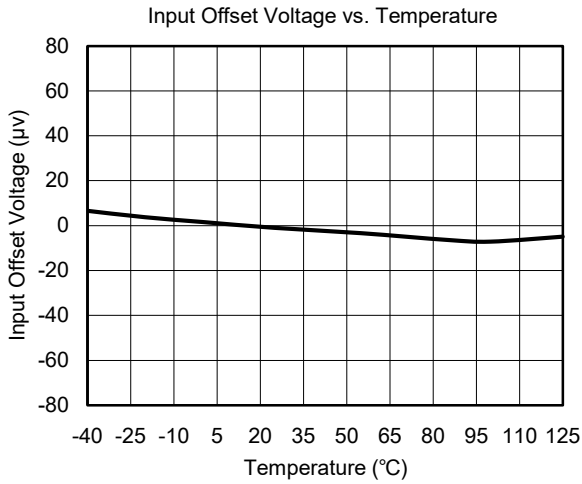

Figure 2. Block Diagram

TYPICAL PERFORMANCE CHARACTERISTICS

T<sub>A</sub> = +25°C, V<sub>S</sub> = 5V, V<sub>IN+</sub> = 12V, unless otherwise noted.



TYPICAL PERFORMANCE CHARACTERISTICS (continued)

T<sub>A</sub> = +25°C, V<sub>S</sub> = 5V, V<sub>IN+</sub> = 12V, unless otherwise noted.

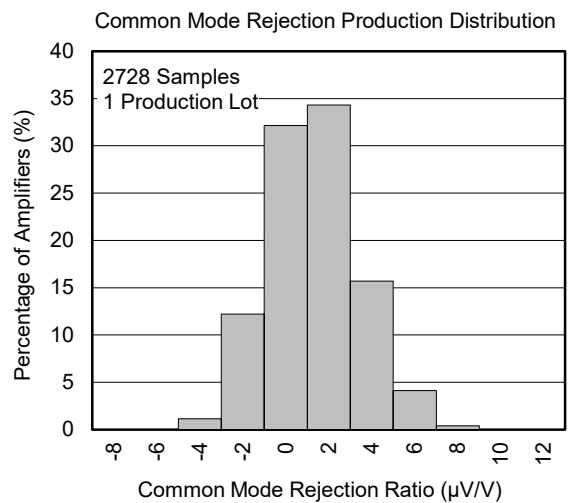
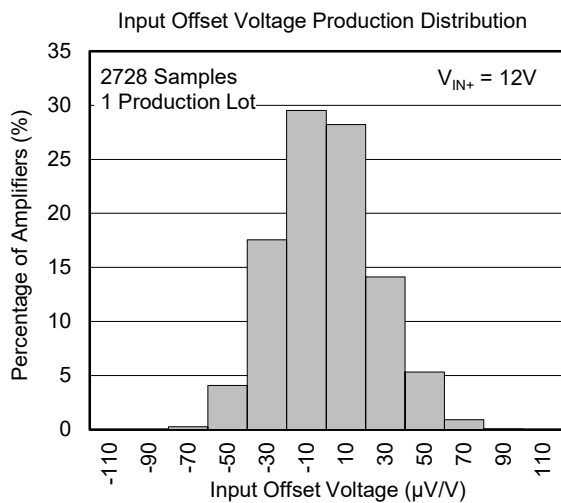
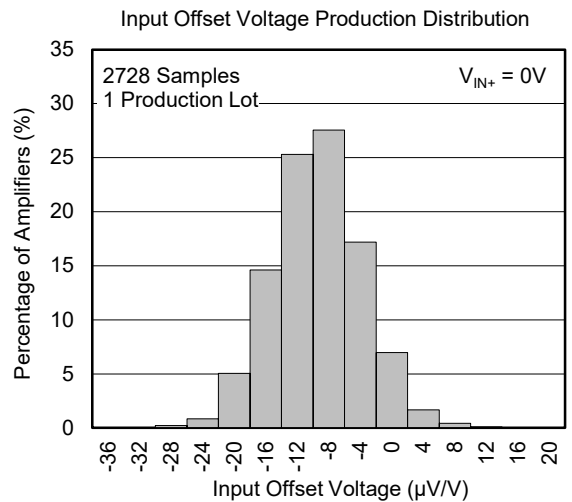
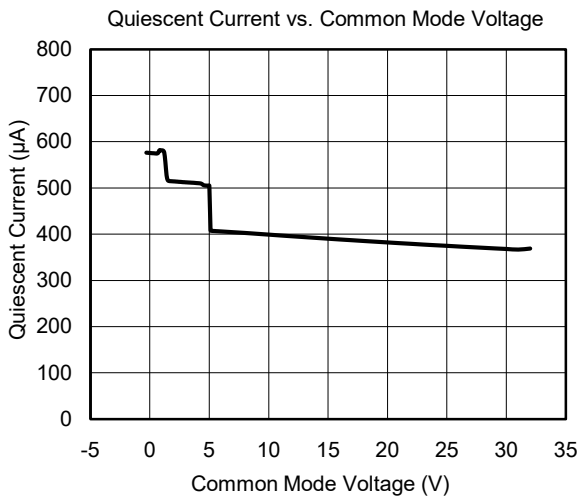
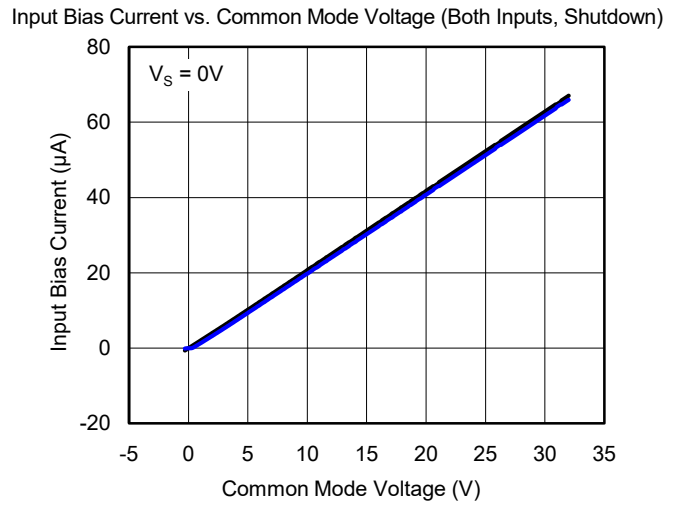
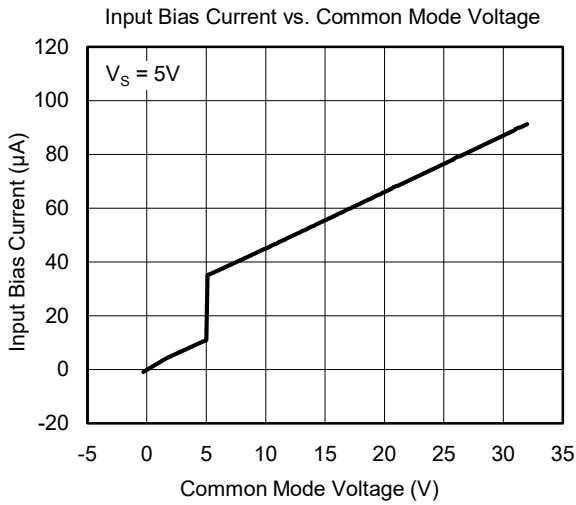

**TYPICAL PERFORMANCE CHARACTERISTICS (continued)**

T<sub>A</sub> = +25°C, V<sub>S</sub> = 5V, V<sub>IN+</sub> = 12V, unless otherwise noted.

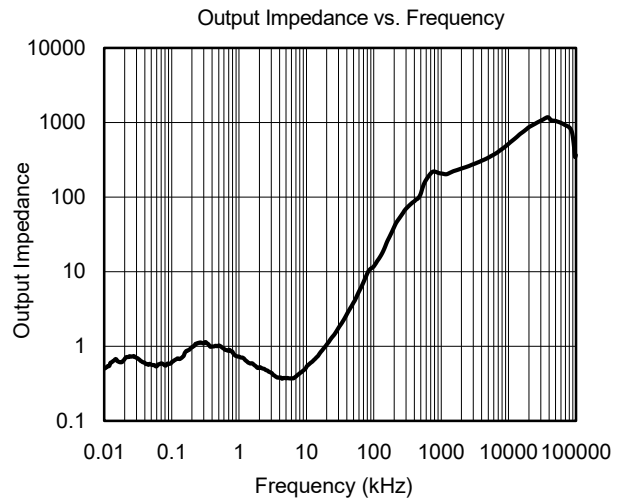
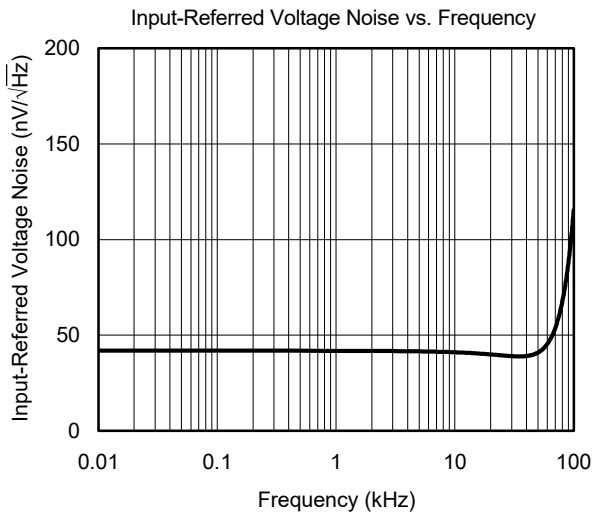
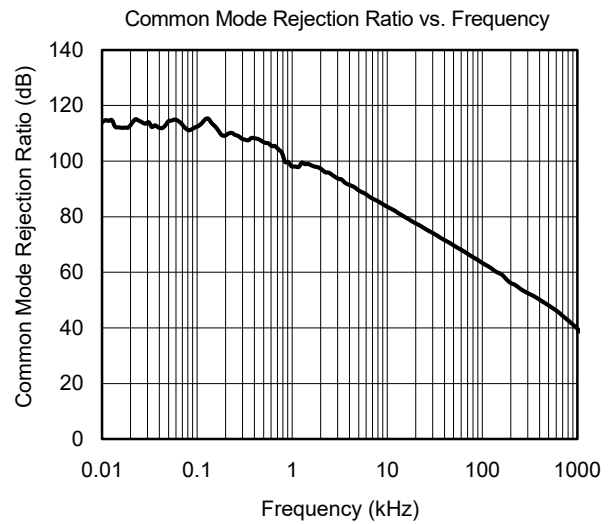
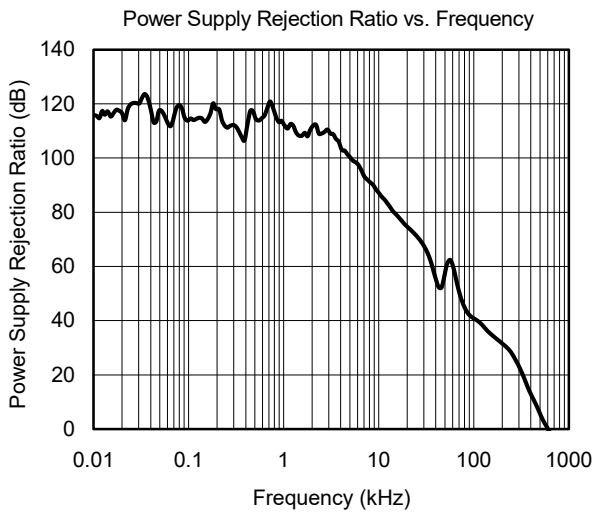
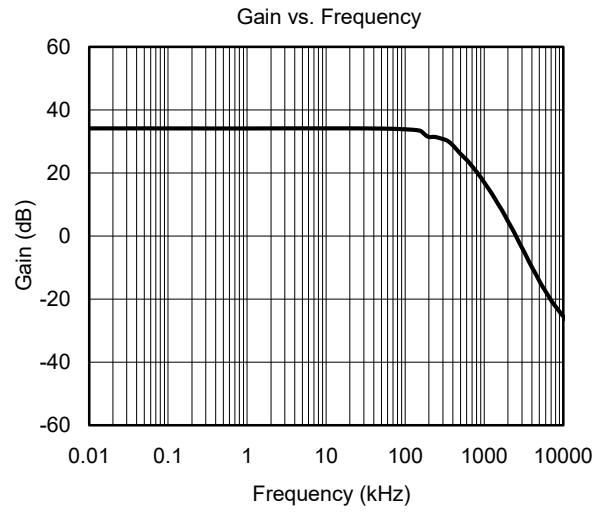
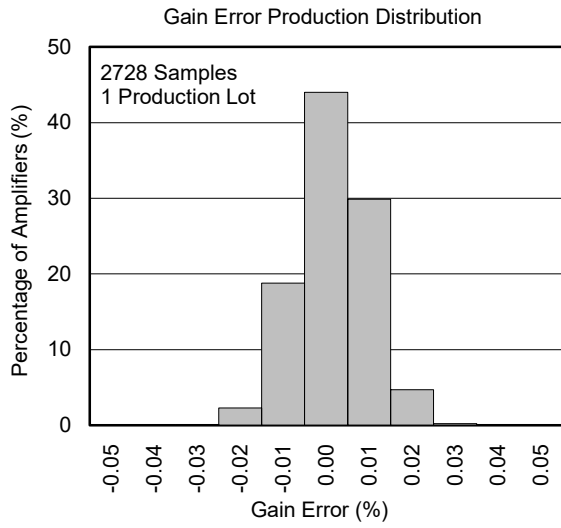

**TYPICAL PERFORMANCE CHARACTERISTICS (continued)**

$T_A = +25^\circ\text{C}$ ,  $V_S = 5\text{V}$ ,  $V_{IN+} = 12\text{V}$ , unless otherwise noted.

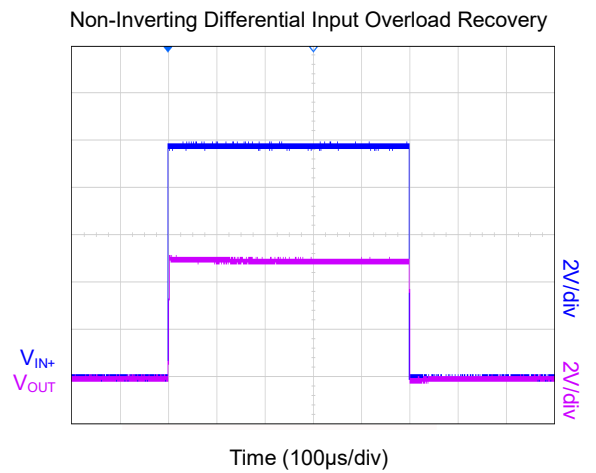
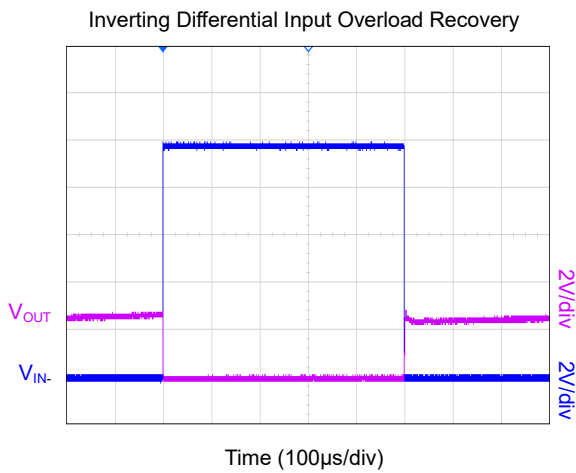
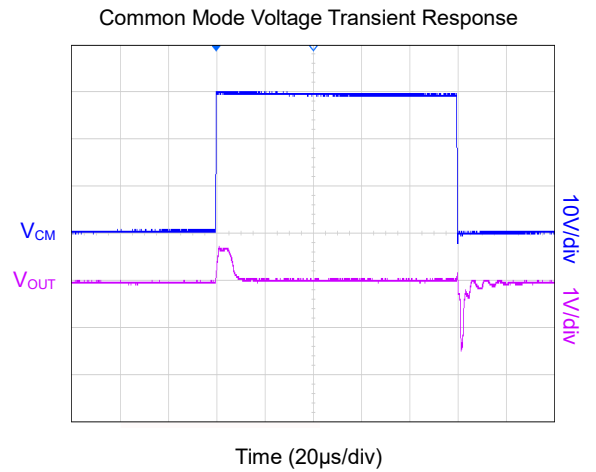
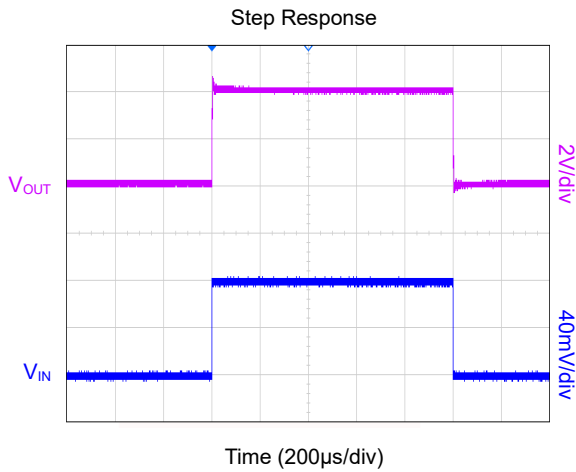
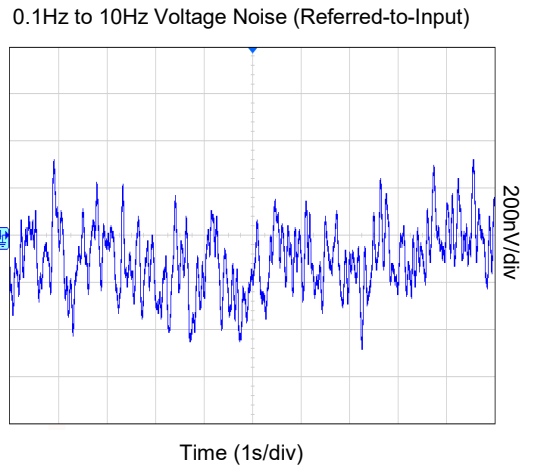
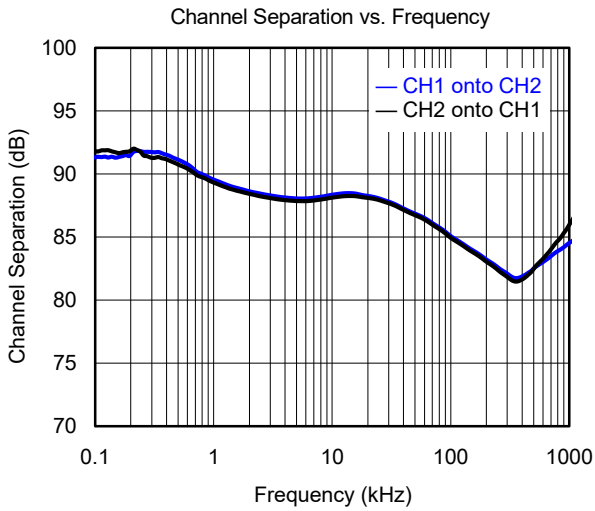

**TYPICAL PERFORMANCE CHARACTERISTICS (continued)**

$T_A = +25^\circ\text{C}$ ,  $V_S = 5\text{V}$ ,  $V_{IN+} = 12\text{V}$ , unless otherwise noted.

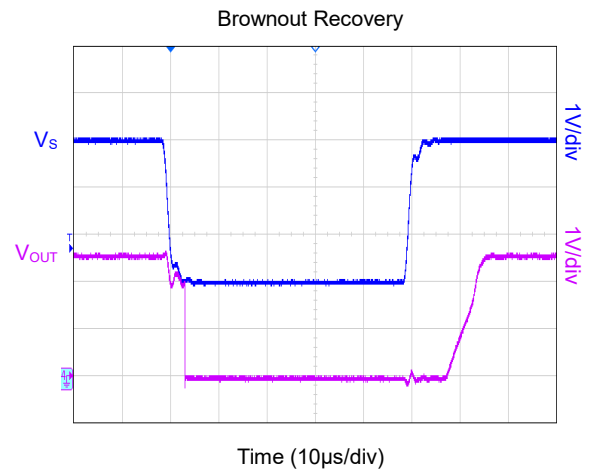
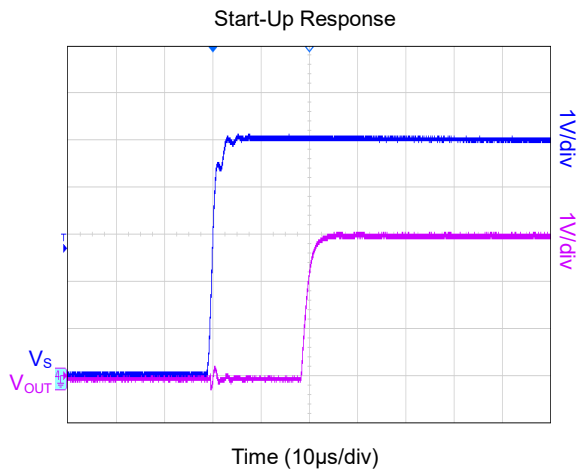

DETAILED DESCRIPTION

Overview

The SGM8192-2 is a current-sensing amplifier that supports both low-side and high-side configurations. Designed for precision measurement, SGM8192-2 accurately resolves voltage differentials across current-sensing resistors even when the common mode voltage exceeds the device’s supply voltage. Operating from a supply as low as 2.7V, the amplifier enables current monitoring on input rails up to 30V.

Feature Description

High Bandwidth and Slew Rate

The SGM8192-2 delivers a small-signal bandwidth up to 270kHz and a large-signal slew rate of 2V/μs. Combined with rapid output slew capability, this performance enables precise monitoring of fast current transients, positioning the SGM8192-2 as an optimal solution for dynamic current-response applications.

Wide Input Common Mode Voltage Range

The SGM8192-2 supports an input common mode voltage range of -0.2V to +30V, independent of its power supply voltage ( $V_S = 2.7V$  to 5.5V). This architectural design decouples the common mode range from the supply voltage, enabling operation even when the input voltage exceeds or falls below  $V_S$ . As shown in Figure 3, this capability allows deployment in both high-side sensing and low-side sensing.

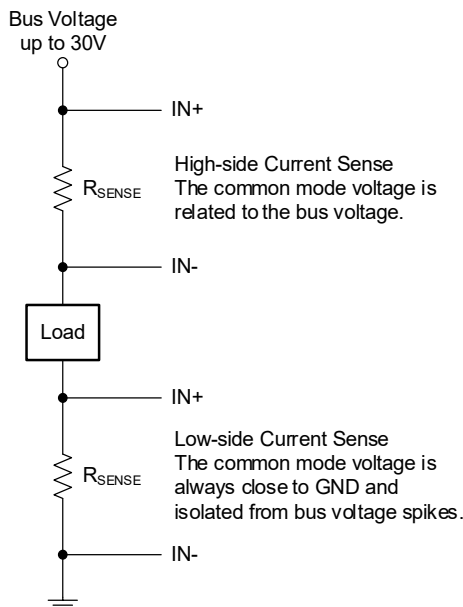

Figure 3. The Typical Connections of High-side and Low-side Mode

Precise Low-side Current Sensing

The SGM8192-2 maintains  $\pm 75\mu V$  input offset voltage in low-side current sensing. This low-offset characteristic enables two key advantages: precise current measurement across wide dynamic ranges (especially at low-current extremes) and accurate sensing of minimal voltage drops across sense resistors. Lower-value shunt resistors can thus be implemented, reducing power loss and improving end-application efficiency.

Rail-to-Rail Output Swing

The SGM8192-2 supports linear current sensing. Its output is proximity to both supply rail (15mV TYP swing) and GND (1mV TYP swing). For output swing comparison between the SGM8192-2 and standard op amps, inputs are intentionally overdriven to emulate open-loop conditions per op amp datasheet specifications. The closed-loop architecture constrains the GND-side output swing by the product of input offset voltage and gain.

For devices with positive input offset voltages, the output swing to GND is constrained by the greater of two values: the product of input offset voltage and amplifier gain, or the GND swing limit specified in the ELECTRICAL CHARACTERISTICS table.

Example Application (SGM8192-2A2, Gain = 50V/V): Assuming a typical input offset voltage of  $60\mu V$ , low-side current sensing yields 3mV output ( $60\mu V \times 50V/V$ ), exceeding the specified negative swing limit. Thus, the GND swing is limited to 3mV. The calculated output at zero differential signal is -3mV ( $-60\mu V \times 50V/V$ ). Here, the negative offset inherently assists in driving the output toward the rail, aligning the GND swing with the ELECTRICAL CHARACTERISTICS table specification.

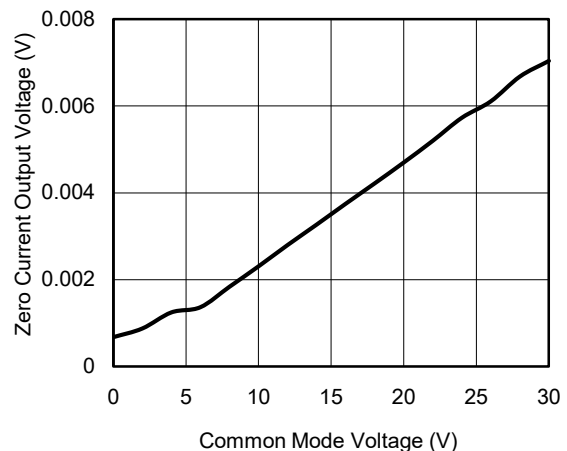

Figure 4. Zero-Current Output Voltage vs. Common Mode Voltage

**DETAILED DESCRIPTION (continued)**

**Functional Modes**

**Normal Operating Mode**

The SGM8192-2 operates normally when the following criteria are satisfied:

- $V_S$  (Power Supply): 2.7V to 5.5V
- $V_{CM}$  (Common Mode Voltage): -0.2V to +30V
- Input Signal Constraints:
  - Maximum: Differential input  $\times$  Gain  $<$  ( $V_S$  - Output swing to  $V_S$ )
  - Minimum: Differential input  $\times$  Gain  $>$  Swing to GND (refer to Rail-to-Rail Output Swing section)

In normal operation, the output voltage linearly scales with the differential voltage between IN+ and IN-, amplified by the device's fixed gain.

**Input Differential Overload**

Overload Behavior: When  $(V_{IN+} - V_{IN-}) \times$  Gain exceeds the output swing limits, the SGM8192-2 saturates its output near  $V_S$ , invalidating measurement accuracy.

Mitigation Strategies:

- Reduce the shunt resistor value to lower differential input voltage.
- Select a lower-gain variant of the SGM8192-2 with the existing shunt resistor.

When the amplified differential input voltage  $(V_{IN+} - V_{IN-}) \times$  Gain exceeds the defined output swing range, the SGM8192-2 enters saturation near the positive supply rail, rendering accurate measurement infeasible. To prevent such operational saturation during standard use, designers may either reduce the shunt resistor value to lower the generated input voltage or opt for a lower-gain device variant while retaining the existing sense resistor configuration. In scenarios where transient overloads arise from fault conditions, the amplifier's output autonomously recovers to its linear operational range following fault elimination, ensuring rapid system restoration without manual intervention.

The SGM8192-2 safeguards operational integrity when its output approaches the positive supply rail or ground reference. Incremental increases in differential input voltage do not compromise device reliability provided all absolute maximum ratings are strictly observed. Through adherence to these operational constraints, the amplifier preserves signal polarity without inducing phase reversal anomalies.

**Shutting Down SGM8192-2**

There is no shutdown control at the internal of SGM8192-2, so the only way to shut down the quiescent current from the power supply is by using an external logic gate or transistor switch.

However, the users may concern about the amount of current through SGM8192-2 in shutdown mode. The schematic in Figure 5 can be used to evaluate the amount of current drain in shutdown mode.

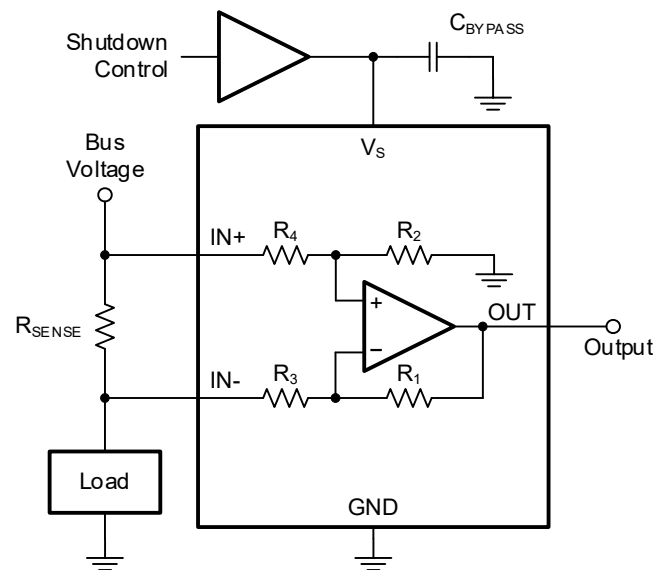

Figure 5. Shutting Down the Current Shunt Monitor

## APPLICATION INFORMATION

The SGM8192-2 current-sense amplifier accurately scales up the voltage generated across a current-sensing shunt resistor during load or ground-referenced current flow.

## Recommended Connection

The recommended connection of SGM8192-2 is shown in Figure 6. Also, it is recommended that the shunt resistor should be placed as close as possible to the two input pins of the current shunt monitor, so the extra resistance which is series with the measured shunt resistor will be reduced.

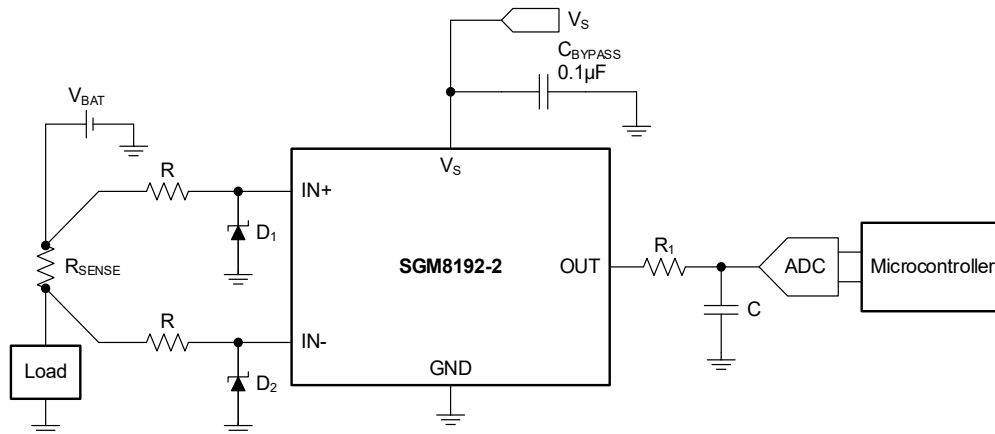

NOTE: To optimize measurement accuracy Establish a direct path with minimal impedance between the SGM8192-2 GND pin and the ground reference of the analog-to-digital converter (ADC) or microcontroller.

Figure 6. Typical Application Circuit for Battery-Powered System

The bypass capacitor is necessary for the current shunt monitor to improve its stability. In most applications, the power supply is noisy and it will affect the operation of SGM8192-2, so the bypass capacitor is needed in this case.

## Power Supply

The SGM8192-2 can accurately measure the current when the common mode voltage exceeds the power supply voltage presented at the  $V_S$  pin. For example, the  $V_S$  power supply can be 5V and the load or common mode power supply voltage is allowed to reach up to 30V. The output voltage range is limited by the level of the power supply.

Selection of  $R_{SENSE}$ 

For the typical range of the differential input, the current shunt monitor of SGM8192-2 can work accurately with the order of 10mV. The application of SGM8192-2 will determine the selection of the shunt resistor  $R_{SENSE}$ . Also, the users should consider the trade-off between voltage loss and the accuracy of small input signals. The effect of offset can be minimized by using high values of  $R_{SENSE}$ , while the voltage loss can be minimized by using low values of  $R_{SENSE}$ . For most applications, a voltage drop of 60mV over  $R_{SENSE}$  is the appropriate range for the selection of  $R_{SENSE}$ , particularly when the supply

voltage  $V_S$  is 5V, as it helps maintain the output signal within a linear range centered near the mid-scale. Under this condition, the corresponding input offset voltage is a maximum of 180μV.

## Input Filtering

It is not recommended to add a filter at the output of SGM8192-2, as doing so increases impedance seen at the output of the internal buffer. Filtering at the input pins will be a good choice as long as the change of the input impedance is taken in account. Figure 7 indicates the application of input filtering.

For minimizing the error and enhancing the accuracy of the result, the resistance of the external resistor  $R_F$  should be less than 10Ω. At the internal input structure of SGM8192-2, there is a bias network which causes mismatch in the bias current of two input pins, and the external resistors result in the mismatch of voltage drops (because of the mismatch of  $I_B$ ) across  $R_F$  so that the differential error will be created. Also, this differential error will be reflected to the input pins of the current shunt monitor and result in the accuracy. However, the bias current difference can result in little effect on the operation of the current shunt monitor so the users do not need to care about that.

APPLICATION INFORMATION (continued)

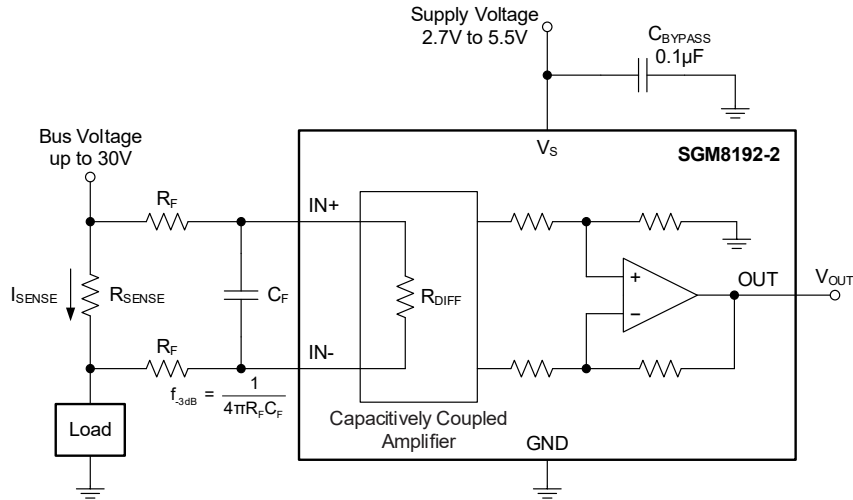

Figure 7. Filtering at Input

The Performance of SGM8192-2 when Common Mode Transients above 30V

The SGM8192-2 can be powered by the power supply whose power-on transient is higher than 30V, especially for the application of automotive industry. At this case, a Zener diode or Zener-type transient absorber (Transzorbs) can be used to prevent the current shunt monitor from over-voltage during the transient of power-on. It does not recommend users to use the transient absorber other than Transzorbs because of the significant time delay. However, any Zener diode needs extra operational resistors to provide the operating current, so the 10Ω resistors are selected (any large external resistor will affect the gain). Also, 10Ω resistors and a Zener diode with lowest rating of power are enough for handling the short-term transient in most applications.

If the low power Zener diode cannot protect the current shunt monitor from supply transient, a Transzorb with high power must be taken into account in this case. In Figure 9, for saving the space of PCB board, a Transzorb and back-to-back diode can also be used to absorb the transient. For the applications of Figure 8 and Figure 9.

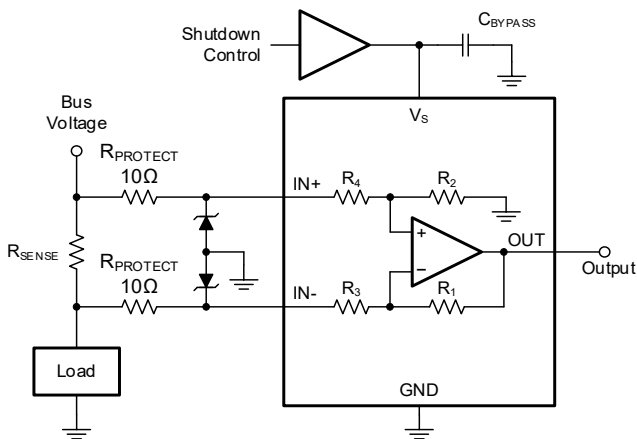

Figure 8. Using Dual Diodes for Absorbing Supply Transient

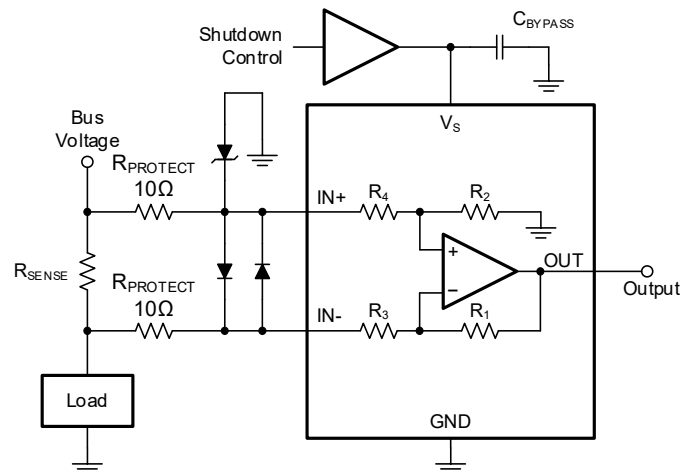

Figure 9. Using Transzorb and Input Clamps for Absorbing Supply Transient

**REVISION HISTORY**

NOTE: Page numbers for previous revisions may differ from page numbers in the current version.

<b>Changes from Original to REV.A (JUNE 2026)</b>	<b>Page</b>
Changed from product preview to production data.....	All

---

PACKAGE OUTLINE DIMENSIONS

MSOP-8

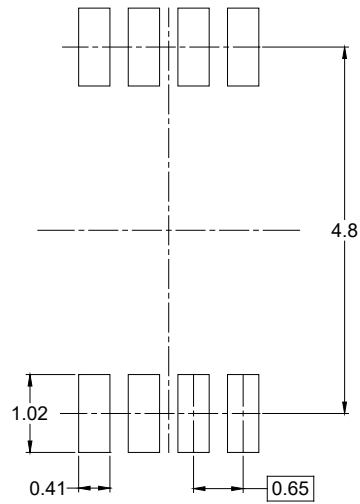
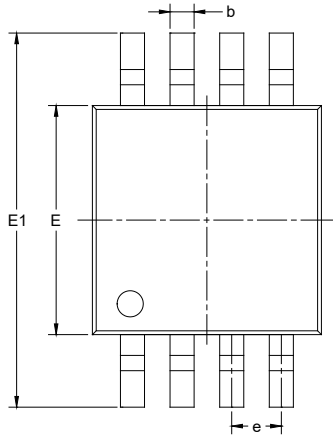

RECOMMENDED LAND PATTERN (Unit: mm)

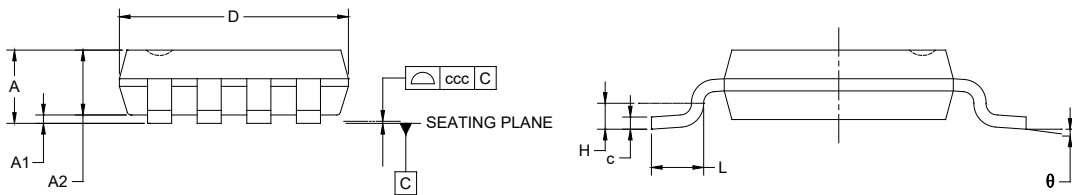

Symbol	Dimensions In Millimeters		
	MIN	NOM	MAX
A	-	-	1.100
A1	0.000	-	0.150
A2	0.750	-	0.950
b	0.220	-	0.380
c	0.080	-	0.230
D	2.800	-	3.200
E	2.800	-	3.200
E1	4.650	-	5.150
e	0.650 BSC		
L	0.400	-	0.800
H	0.250 TYP		
θ	0°	-	8°
ccc	0.100		

NOTES:

1. This drawing is subject to change without notice.
2. The dimensions do not include mold flashes, protrusions or gate burrs.
3. Reference JEDEC MO-187.

PACKAGE OUTLINE DIMENSIONS

TDFN-2x2-8AL

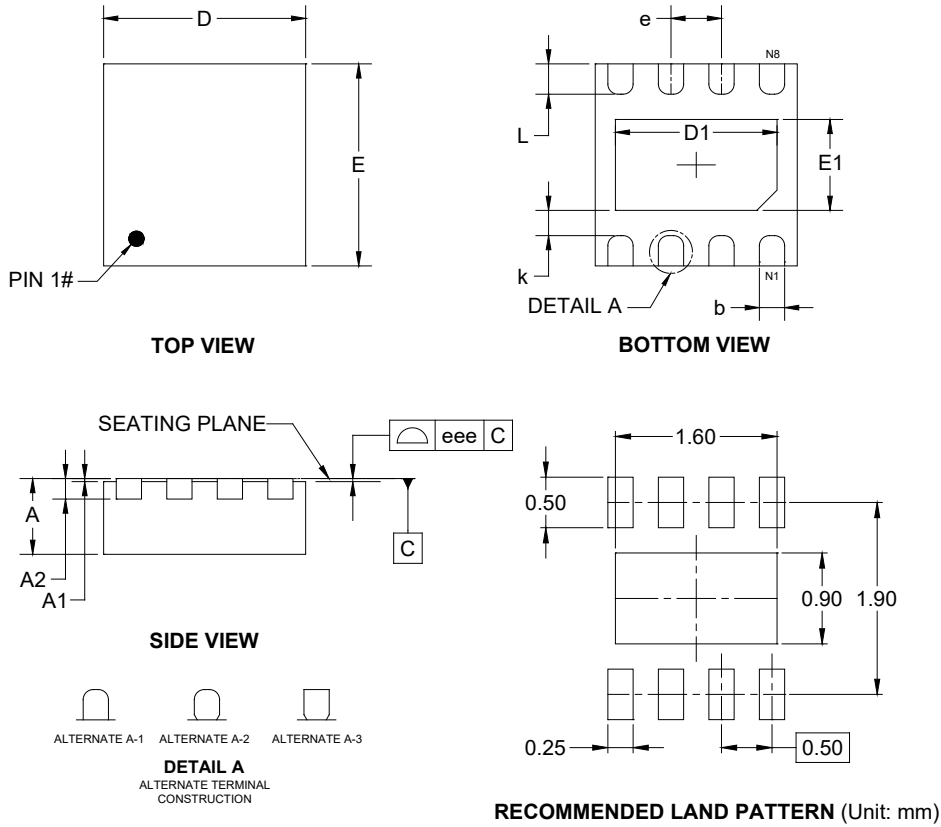

Symbol	Dimensions In Millimeters		
	MIN	NOM	MAX
A	0.700	-	0.800
A1	0.000	-	0.050
A2	0.203 REF		
b	0.200	-	0.300
D	1.900	-	2.100
D1	1.450	-	1.700
E	1.900	-	2.100
E1	0.750	-	1.000
k	0.200	-	-
e	0.500 BSC		
L	0.200	-	0.400
eee	0.080		

NOTE: This drawing is subject to change without notice.

**TAPE AND REEL INFORMATION**

**REEL DIMENSIONS**

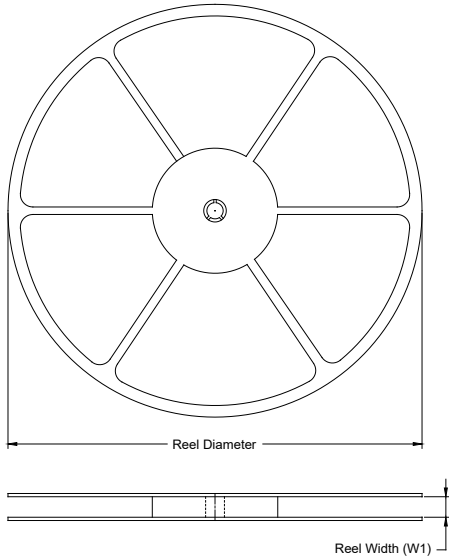

**TAPE DIMENSIONS**

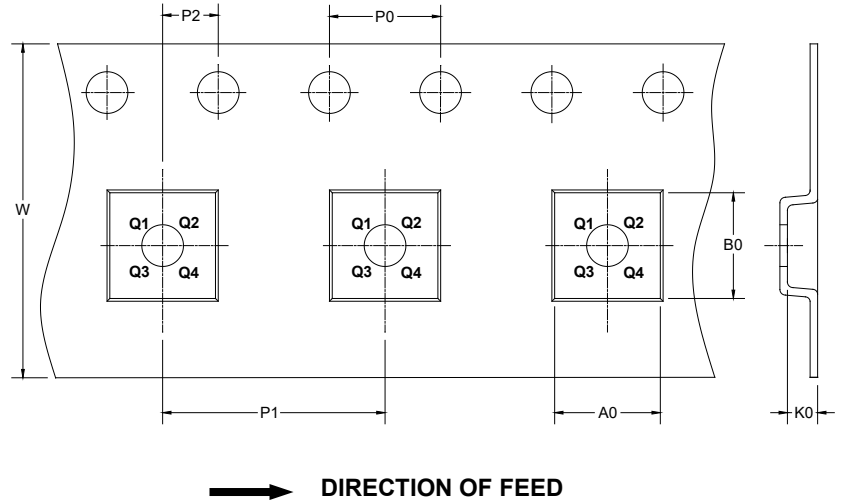

NOTE: The picture is only for reference. Please make the object as the standard.

**KEY PARAMETER LIST OF TAPE AND REEL**

Package Type	Reel Diameter	Reel Width W1 (mm)	A0 (mm)	B0 (mm)	K0 (mm)	P0 (mm)	P1 (mm)	P2 (mm)	W (mm)	Pin1 Quadrant
MSOP-8	13"	12.4	5.20	3.30	1.50	4.0	8.0	2.0	12.0	Q1
TDFN-2x2-8AL	7"	9.5	2.30	2.30	1.10	4.0	4.0	2.0	8.0	Q2

D20001

# PACKAGE INFORMATION

## CARTON BOX DIMENSIONS

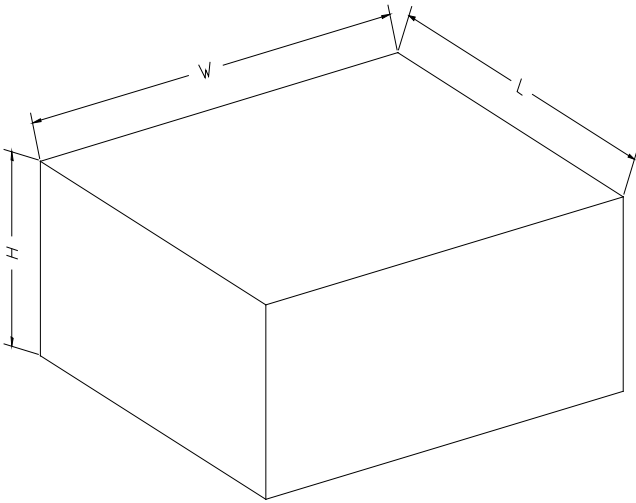

NOTE: The picture is only for reference. Please make the object as the standard.

## KEY PARAMETER LIST OF CARTON BOX

Reel Type	Length (mm)	Width (mm)	Height (mm)	Pizza/Carton
7" (Option)	368	227	224	8
7"	442	410	224	18
13"	386	280	370	5

DD0002