

GENERAL DESCRIPTION

The SGM25117A is an advanced load management switch with low on-resistance. The adjustable slew rate can effectively limit the inrush current.

The SGM25117A integrates a power good indication function and a series of fault protection functions. The device is widely used in hot-swap and load management applications, especially in applications with space limited and low power consumption requirements.

The SGM25117A is available in a Green TDFN-3x3-12AL package.

APPLICATIONS

- Set-Top Boxes
- Notebooks
- Tablet Computers
- Servers and Gateways
- Portable Systems
- Telecom and Networking Equipment
- Medical and Industrial Equipment
- Hot-Swap Devices

FEATURES

- **Input Voltage Range: 0.5V to 13.5V**
- **Ultra-Low On-Resistance: 3.3mΩ (TYP) at $V_{IN} = 5V$**
- **Integrate Charge Pump**
- **Programmable Slew Rate**
- **Soft-Start Function via Controlled Slew Rate**
- **Power Good Indication**
- **Enable Pin: Active-High**
- **Full Set of Protections**
 - ◆ **Thermal Shutdown**
 - ◆ **Under-Voltage Lockout**
 - ◆ **Short-Circuit Protection**
- **Extremely Low Standby Current**
- **Quick Output Discharge (QOD)**
- **Available in a Green TDFN-3x3-12AL Package**

TYPICAL APPLICATION

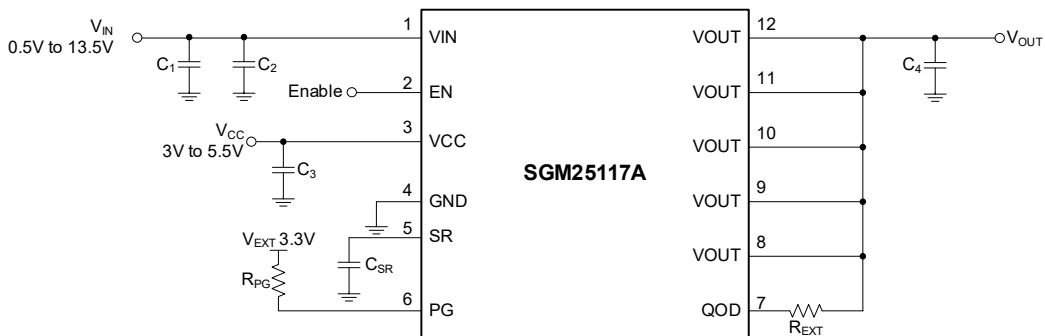

Figure 1. Typical Application Circuit

PACKAGE/ORDERING INFORMATION

MODEL	PACKAGE DESCRIPTION	SPECIFIED TEMPERATURE RANGE	ORDERING NUMBER	PACKAGE MARKING	PACKING OPTION
SGM25117A	TDFN-3×3-12AL	-40°C to +125°C	SGM25117AXTGM12G/TR	SGM 25117 XXXXX	Tape and Reel, 4000

MARKING INFORMATION

NOTE: XXXXX = Date Code, Trace Code and Vendor Code.

XXXXX

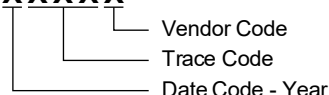

Green (RoHS & HSF): SG Micro Corp defines "Green" to mean Pb-Free (RoHS compatible) and free of halogen substances. If you have additional comments or questions, please contact your SGMICRO representative directly.

ABSOLUTE MAXIMUM RATINGS

Supply Voltage Range, V_{CC}	-0.3V to 6V
Input Voltage Range, V_{IN}	-0.3V to 18V
Output Voltage Range, V_{OUT}	-0.3V to 18V
EN Digital Input Range, V_{EN}	-0.3V to $V_{CC} + 0.3$
PG Output Voltage Range, V_{PG}	-0.3V to 6V
Continuous MOSFET Current @ $T_A = +25^\circ\text{C}$ ⁽¹⁾ , I_{MAX}	17A
Continuous MOSFET Current @ $T_A = +25^\circ\text{C}$ ⁽²⁾ , I_{MAX}	18.3A
Transient MOSFET Current (for up to 500 μs), I_{MAX_TRANS}	40A
Latch-Up Current Immunity ⁽³⁾	100mA
Package Thermal Resistance	
TDFN-3×3-12AL, θ_{JA}	32.1°C/W
TDFN-3×3-12AL, θ_{JB}	10.1°C/W
TDFN-3×3-12AL, $\theta_{JC(TOP)}$	41.7°C/W
TDFN-3×3-12AL, $\theta_{JC(BOT)}$	1.9°C/W
Junction Temperature	+150°C
Storage Temperature Range	-65°C to +150°C
Lead Temperature (Soldering, 10s)	+260°C
ESD Susceptibility	
HBM	3000V
CDM	1000V

NOTES:

- The minimum surface-mounted on FR4 board is recommended pad 1 oz Cu.
- The minimum surface-mounted on FR4 is recommended 1 sq-in pad size and 1 oz Cu.
- V_{IN} and V_{OUT} pins are not included. The two pins are connected to drain and source of the internal MOSFET. The ESD performance of MOSFET's V_{IN} and V_{OUT} pins should be expected, and these devices are considered ESD-sensitive.

RECOMMENDED OPERATING CONDITIONS

Supply Voltage, V_{CC}	3V to 5.5V
Input Voltage, V_{IN}	0.5V to 13.5V
Off to On Transition Energy Dissipation Limit, E_{TRANS}	0mJ to 210mJ
Operating Junction Temperature Range, T_J	-40°C to +125°C

OVERSTRESS CAUTION

Stresses beyond those listed in Absolute Maximum Ratings may cause permanent damage to the device. Exposure to absolute maximum rating conditions for extended periods may affect reliability. Functional operation of the device at any conditions beyond those indicated in the Recommended Operating Conditions section is not implied.

ESD SENSITIVITY CAUTION

This integrated circuit can be damaged if ESD protections are not considered carefully. SGMICRO recommends that all integrated circuits be handled with appropriate precautions. Failure to observe proper handling and installation procedures can cause damage. ESD damage can range from subtle performance degradation to complete device failure. Precision integrated circuits may be more susceptible to damage because even small parametric changes could cause the device not to meet the published specifications.

DISCLAIMER

SG Micro Corp reserves the right to make any change in circuit design, or specifications without prior notice.

PIN CONFIGURATION

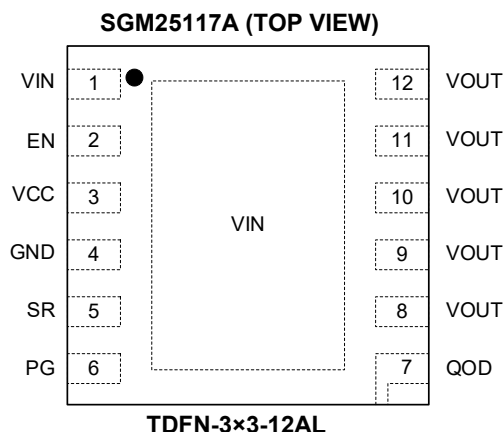

PIN DESCRIPTION

PIN	NAME	FUNCTION
1, Exposed Pad	VIN	Drain of MOSFET (0.5V to 13.5V). Pin 1 and the exposed pad must be connected together.
2	EN	Enable Pin. Logic high on this pin will turn on the MOSFET, which is integrated with internal pull-down resistor.
3	VCC	Supply Voltage to Controller (3V to 5.5V).
4	GND	Ground.
5	SR	Programmable Slew Rate. Keep in floating when not used.
6	PG	Power Good Indicator Pin (Active-High, Open-Drain). The V_{DS} voltage of the external MOSFET determines its state. The PG pin requires a large than 1kΩ external pull-up resistor to an external voltage source. If the pin is not used, it needs to be connected to GND.
7	QOD	Quick Output Discharge. Connect it directly to VOUT or through a resistor less than 1kΩ.
8, 9, 10, 11, 12	VOUT	Source of MOSFET. They are connected to load.

ELECTRICAL CHARACTERISTICS

(T_J = +25°C, unless otherwise noted.)

PARAMETER	SYMBOL	CONDITIONS	MIN	TYP	MAX	UNITS
MOSFET						
On-Resistance	R _{DSON}	V _{CC} = 3.3V, V _{IN} = 1.8V		3.2	6.3	mΩ
		V _{CC} = 3.3V, V _{IN} = 3.3V		3.2 ⁽¹⁾	6.3 ⁽¹⁾	
		V _{CC} = 3.3V, V _{IN} = 5V		3.3	6.3	
		V _{CC} = 3.3V, V _{IN} = 12V		3.7	6.8	
Drain Leakage Current	I _{LEAK}	V _{EN} = 0V, V _{IN} = 13.5V		0.1	1	μA
Controller						
Supply Standby Current	I _{STBY}	V _{EN} = 0V, V _{CC} = 3V		0.57	2	μA
		V _{EN} = 0V, V _{CC} = 5.5V		1.1	4.5	
Supply Dynamic Current	I _{DYN}	V _{EN} = V _{CC} = 3V, V _{IN} = 12V		250	350	μA
		V _{EN} = V _{CC} = 5.5V, V _{IN} = 1.8V		360	500	
Discharge Resistance	R _{QOD}	V _{EN} = 0V, V _{CC} = 3V	95	110	130	Ω
		V _{EN} = 0V, V _{CC} = 5.5V	87	105	123	
QOD Pin Leakage Current	I _{QOD}	V _{EN} = V _{CC} = 3V, V _{IN} = 1.8V		6	10	μA
		V _{EN} = V _{CC} = 3V, V _{IN} = 12V		45	80	
EN Input High Voltage	V _{IH}	V _{CC} = 3V to 5.5V	2.0			V
EN Input Low Voltage	V _{IL}	V _{CC} = 3V to 5.5V			0.8	V
EN Input Leakage Current	I _{IL}	V _{EN} = 0V		10	500	nA
EN Pull-Down Resistance	R _{PD}		80	110	135	kΩ
PG Output Low Voltage	V _{OL}	V _{CC} = 3V, I _{SIK} = 5mA			200	mV
PG Output Leakage Current	I _{OH}	V _{CC} = 3V, V _{EXT} = 3.3V		5	150	nA
Slew Rate Control Constant	K _{SR}	V _{CC} = 3V	26	36	45	μA
Fault Protections						
Thermal Shutdown Threshold ⁽²⁾	T _{SD}	V _{CC} = 3V to 5.5V		150		°C
Thermal Shutdown Hysteresis ⁽²⁾	T _{HYS}	V _{CC} = 3V to 5.5V		25		°C
VIN Under-Voltage Lockout Threshold	V _{UVLO_H}	V _{CC} = 3V	0.29	0.4	0.49	V
	V _{UVLO_L}		0.25	0.36	0.45	
VIN Under-Voltage Lockout Hysteresis	V _{HYS}	V _{CC} = 3V		40		mV
Short-Circuit Protection Threshold	V _{SC}	V _{CC} = 3V, V _{IN} = 0.5V	170	270	370	mV
		V _{CC} = 3V, V _{IN} = 13.5V	110	286	480	

NOTES:

- Guaranteed by design.
- Operation above T_J = +125°C is not guaranteed.

ELECTRICAL CHARACTERISTICS (continued)

(V_{EXT} = V_{CC}, R_{PG} = 100kΩ, R_L = 10Ω, C_L = 0.1μF and T_J = +25°C, unless otherwise noted.)

PARAMETER	SYMBOL	CONDITIONS	MIN	TYP	MAX	UNITS
Output Slew Rate	SR	V _{CC} = 3.3V, V _{IN} = 1.8V		14.6		kV/s
		V _{CC} = 5.0V, V _{IN} = 1.8V		14.0		
		V _{CC} = 3.3V, V _{IN} = 12V		12.6		
		V _{CC} = 5.0V, V _{IN} = 12V		12.9		
Output Turn-On Delay	t _{ON}	V _{CC} = 3.3V, V _{IN} = 1.8V		190		μs
		V _{CC} = 5.0V, V _{IN} = 1.8V		212		
		V _{CC} = 3.3V, V _{IN} = 12V		290		
		V _{CC} = 5.0V, V _{IN} = 12V		306		
Output Turn-Off Delay	t _{OFF}	V _{CC} = 3.3V, V _{IN} = 1.8V		5.7		μs
		V _{CC} = 5.0V, V _{IN} = 1.8V		6.2		
		V _{CC} = 3.3V, V _{IN} = 12V		1.1		
		V _{CC} = 5.0V, V _{IN} = 12V		1.1		
Power Good Turn-On Time	t _{PG_ON}	V _{CC} = 3.3V, V _{IN} = 1.8V		1.7		ms
		V _{CC} = 5.0V, V _{IN} = 1.8V		1.7		
		V _{CC} = 3.3V, V _{IN} = 12V		1.8		
		V _{CC} = 5.0V, V _{IN} = 12V		1.8		
Power Good Turn-Off Time	t _{PG_OFF}	V _{CC} = 3.3V, V _{IN} = 1.8V		31.4		ns
		V _{CC} = 5.0V, V _{IN} = 1.8V		21.8		
		V _{CC} = 3.3V, V _{IN} = 12V		28.2		
		V _{CC} = 5.0V, V _{IN} = 12V		21.4		

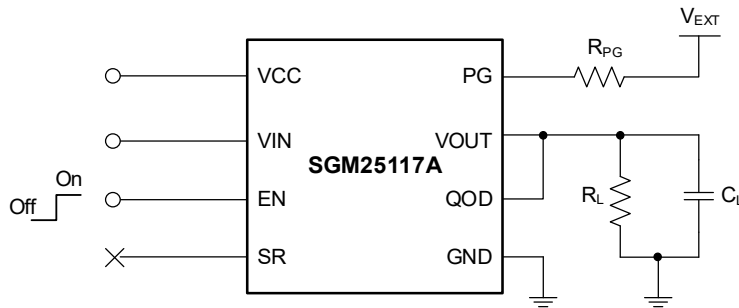

Figure 2. Test Circuit

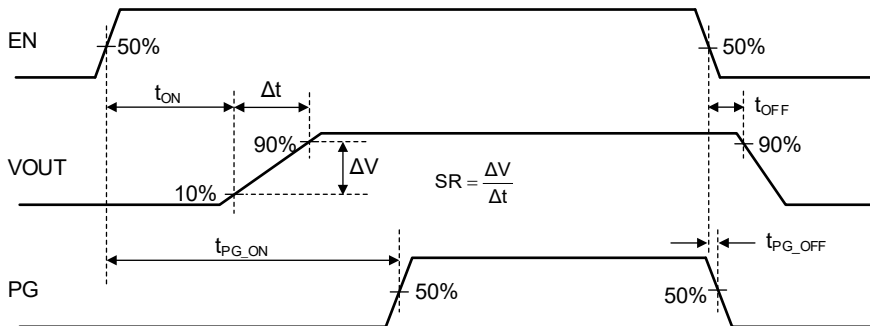
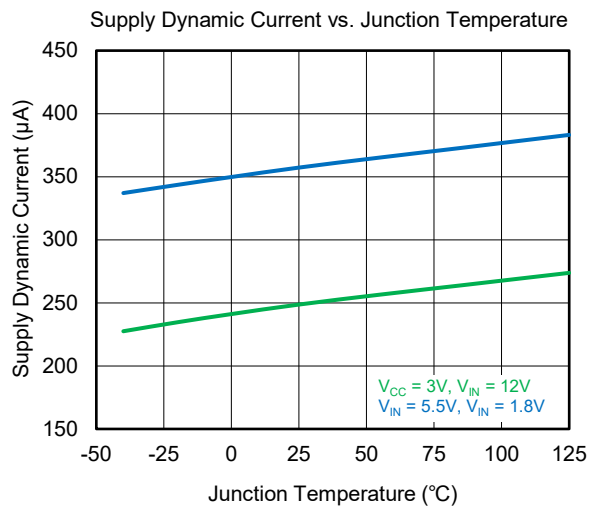
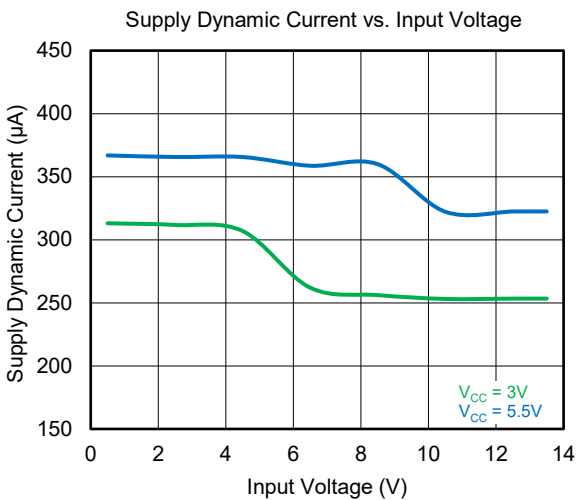
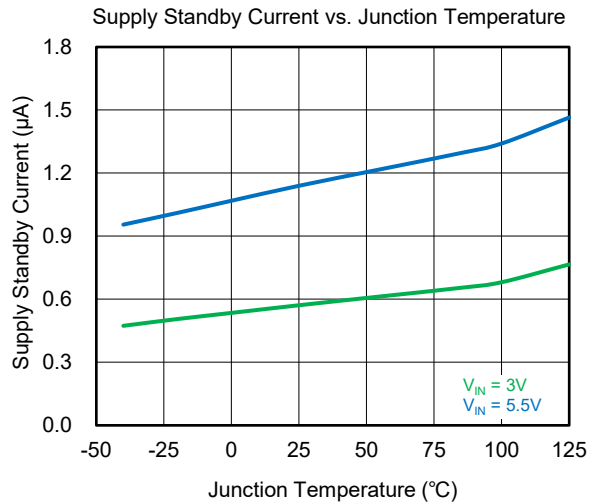
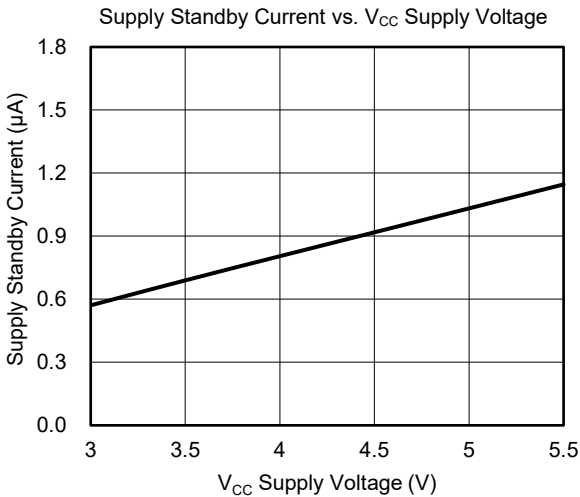
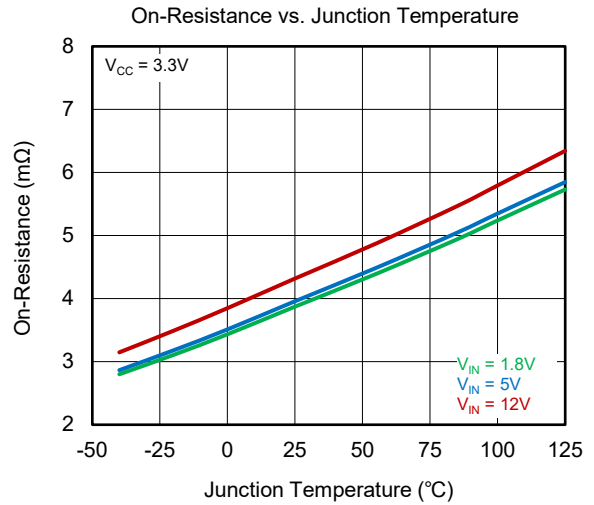
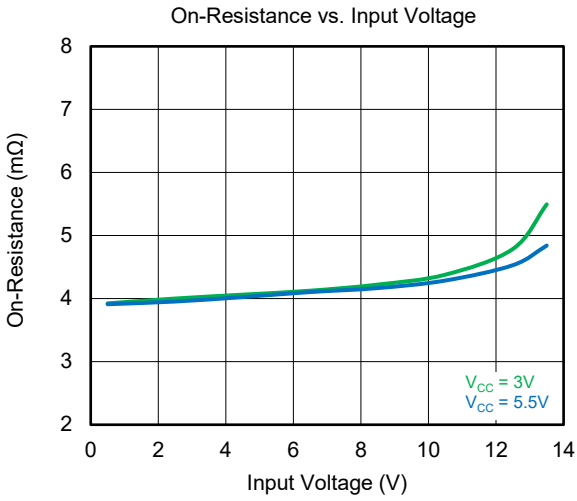

Figure 3. Timing Diagram

TYPICAL PERFORMANCE CHARACTERISTICS

$T_J = +25^\circ\text{C}$, unless otherwise noted.



TYPICAL PERFORMANCE CHARACTERISTICS (continued)

$T_J = +25^\circ\text{C}$, unless otherwise noted.

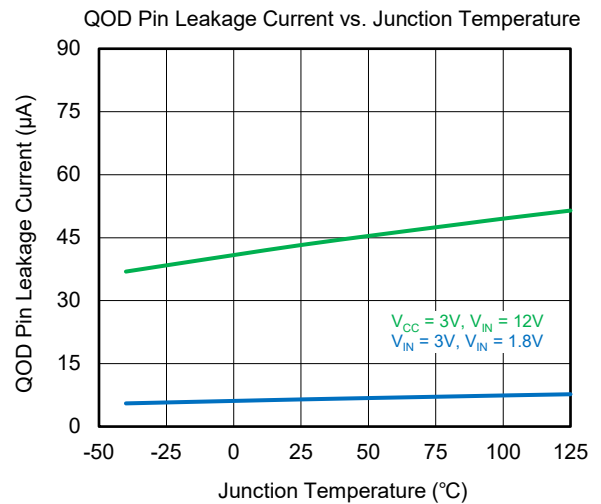
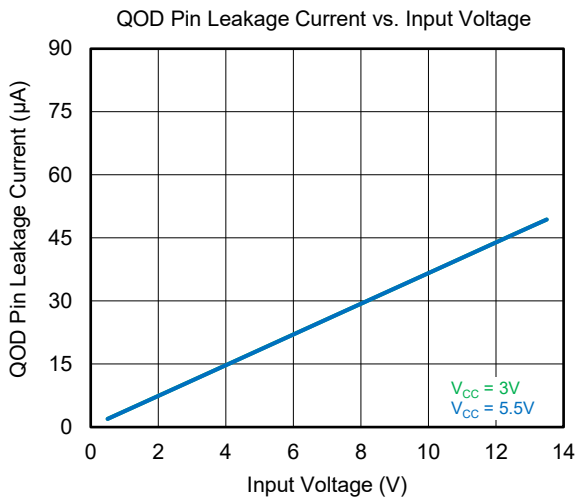
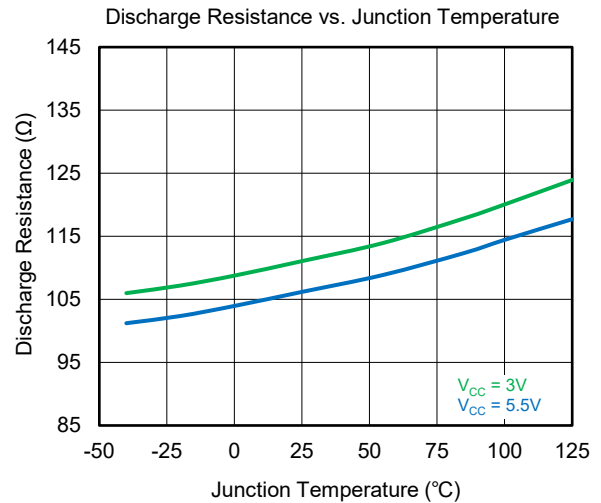
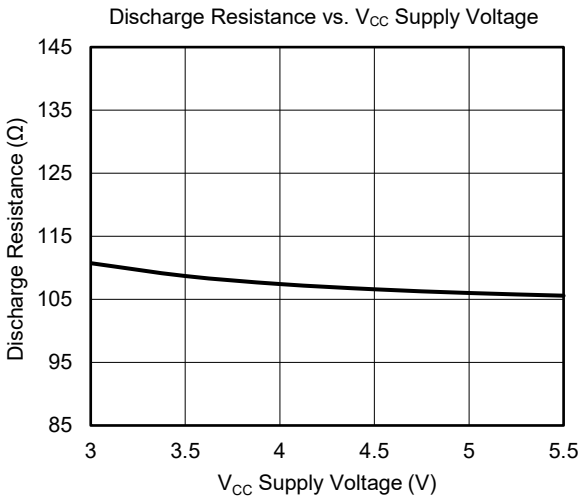
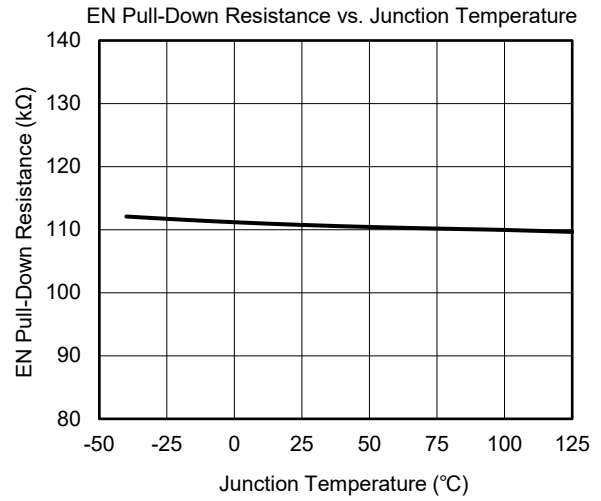
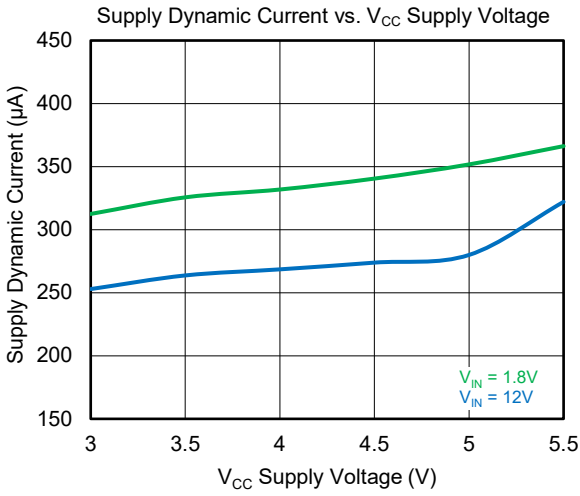

TYPICAL PERFORMANCE CHARACTERISTICS (continued)

$T_J = +25^\circ\text{C}$, unless otherwise noted.

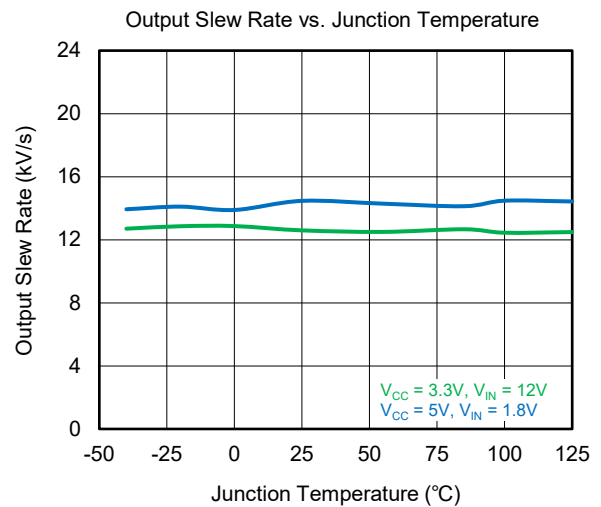
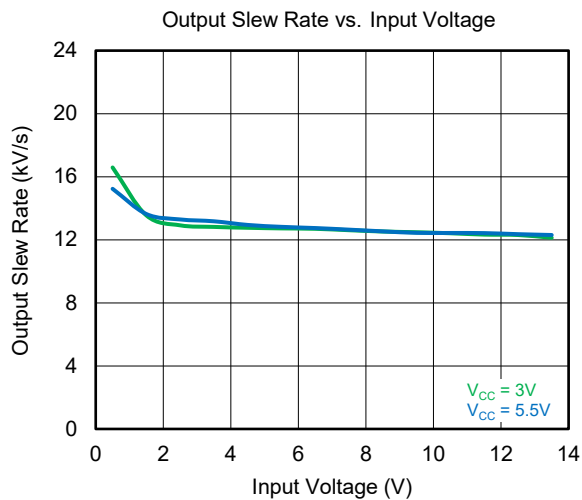
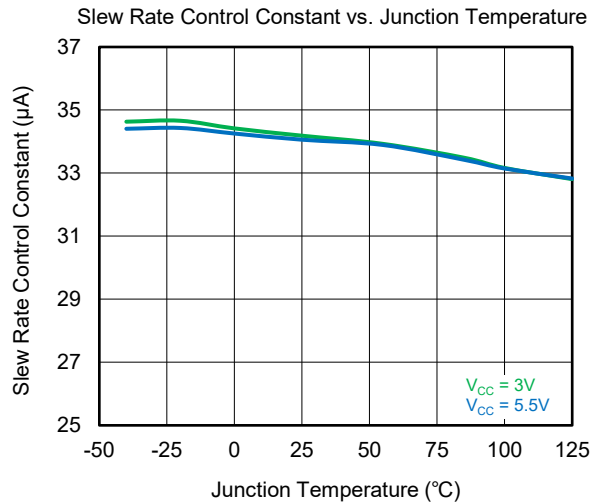
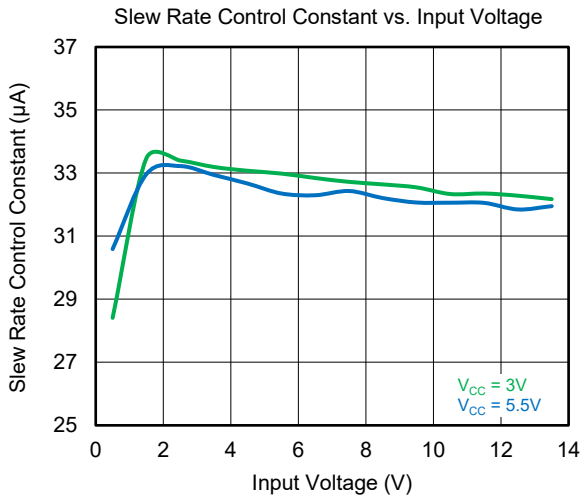
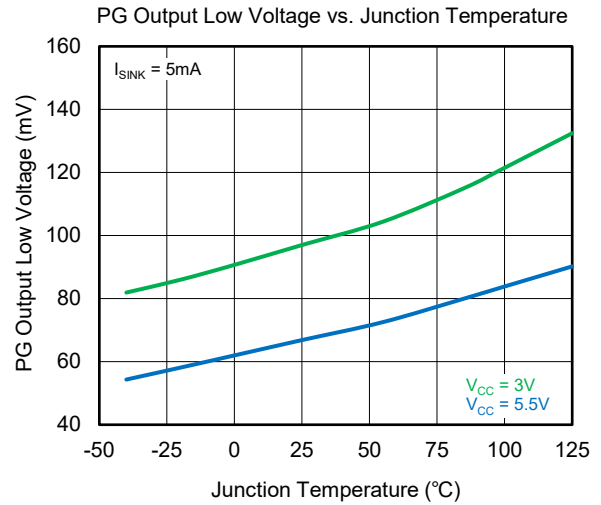
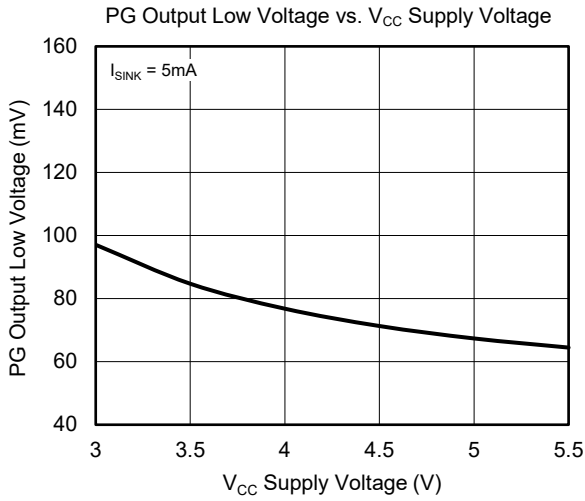

TYPICAL PERFORMANCE CHARACTERISTICS (continued)

$T_J = +25^\circ\text{C}$, unless otherwise noted.

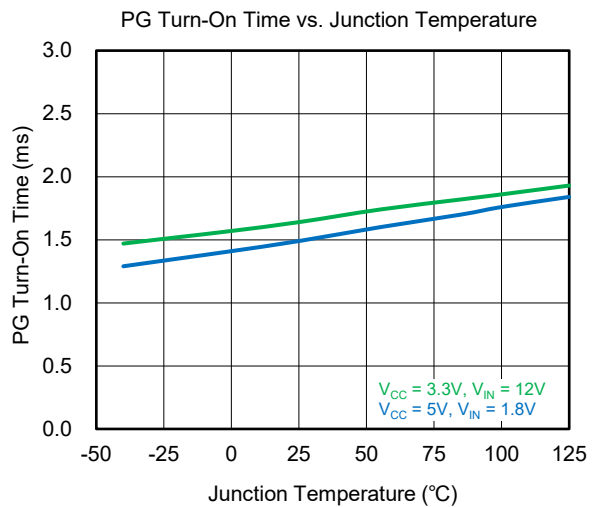
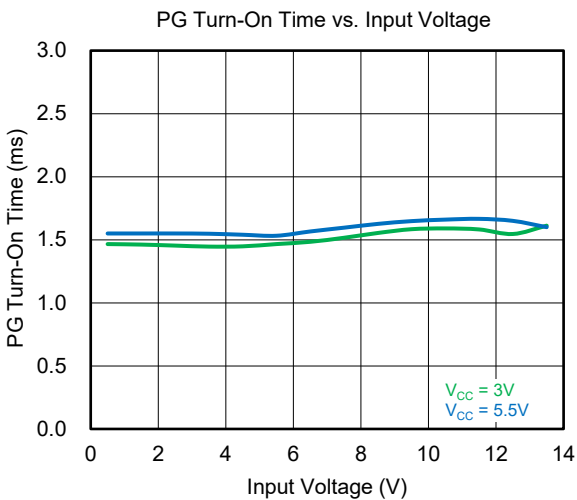
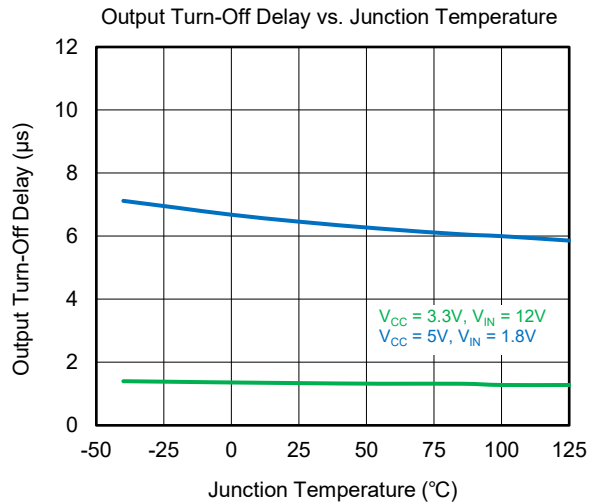
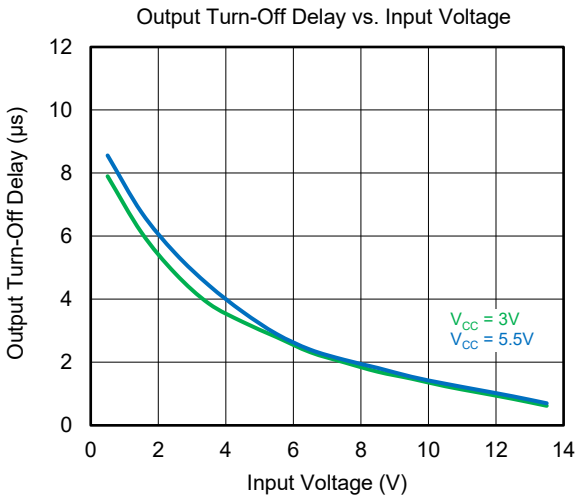
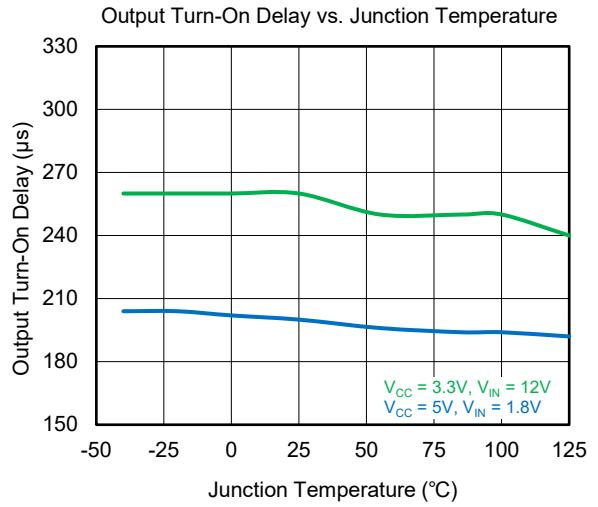
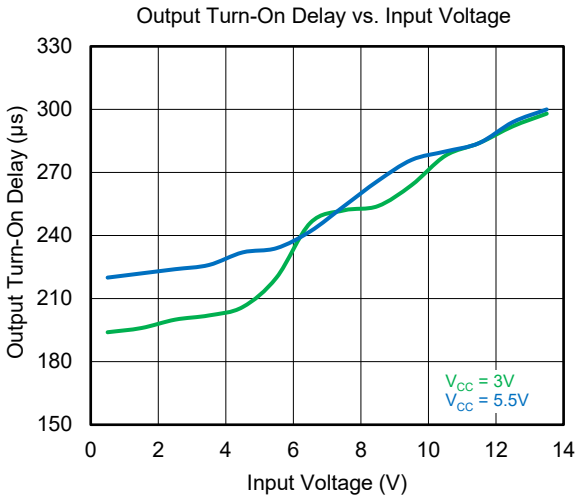

TYPICAL PERFORMANCE CHARACTERISTICS (continued)

$T_J = +25^\circ\text{C}$, unless otherwise noted.

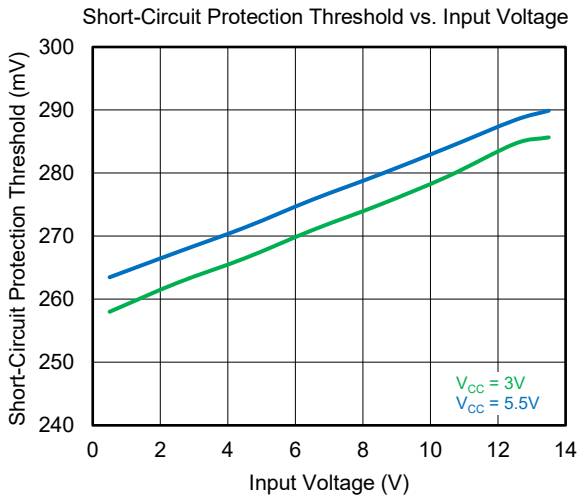
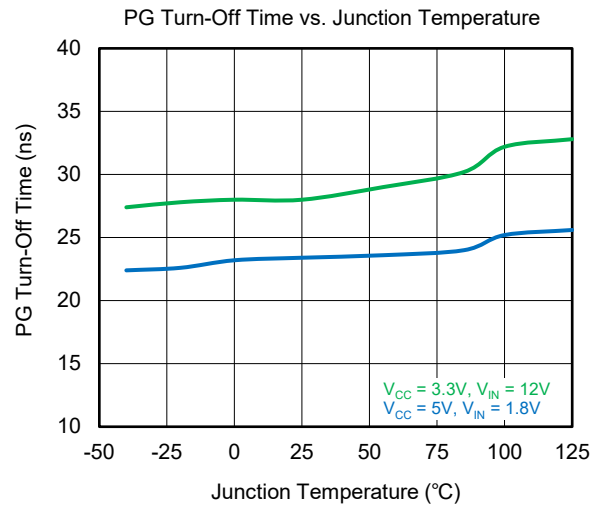
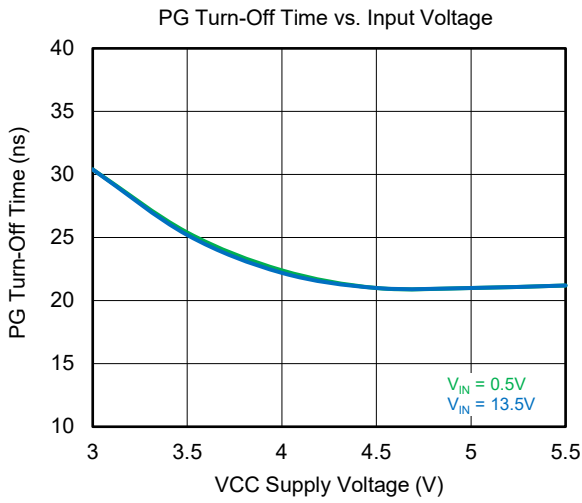

TYPICAL APPLICATION CIRCUITS

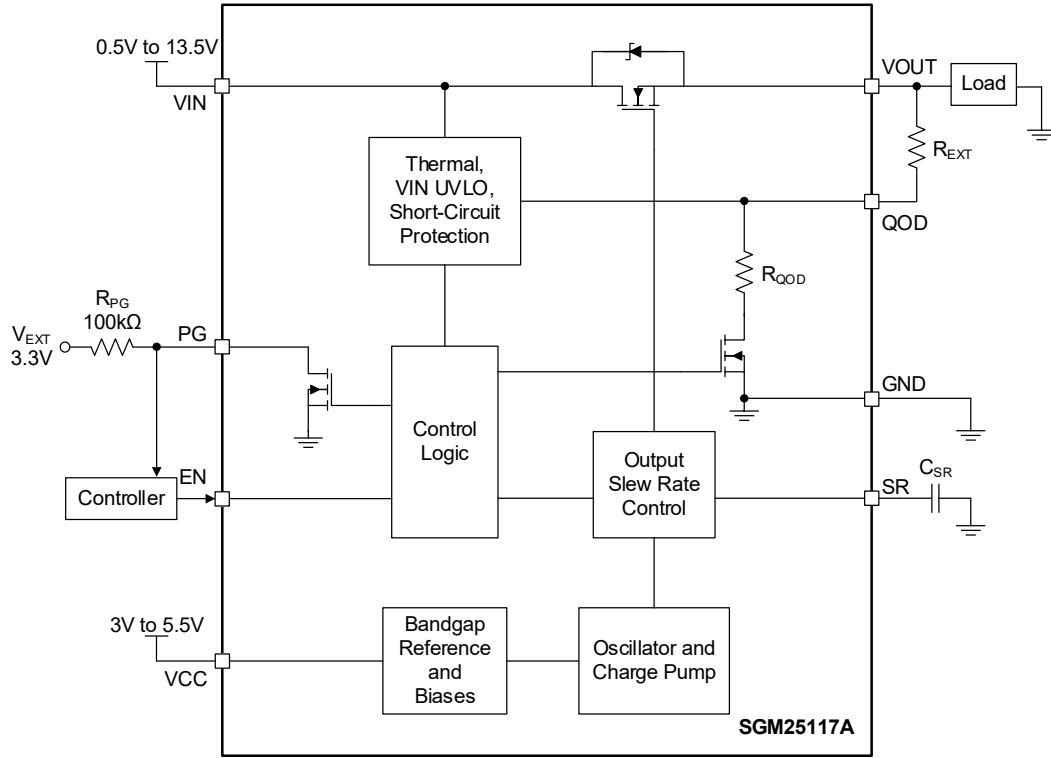

Figure 4. Load Switch

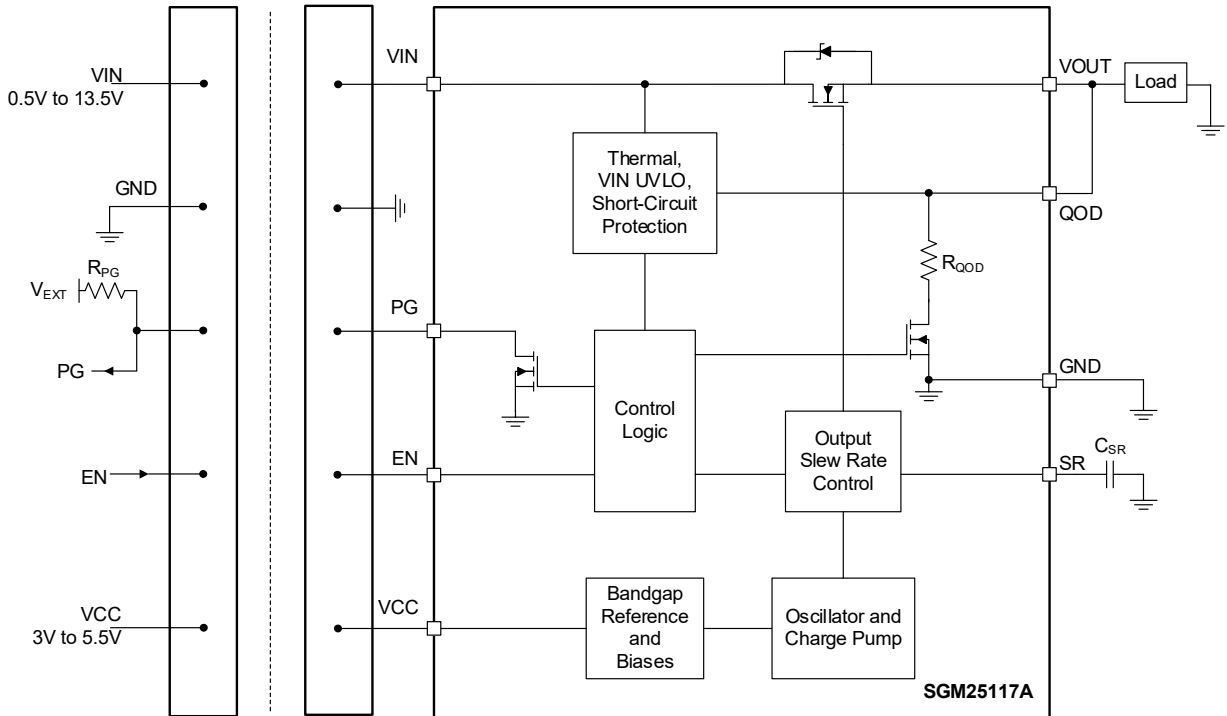

Figure 5. Hot-Swap

TYPICAL APPLICATION CIRCUITS (continued)

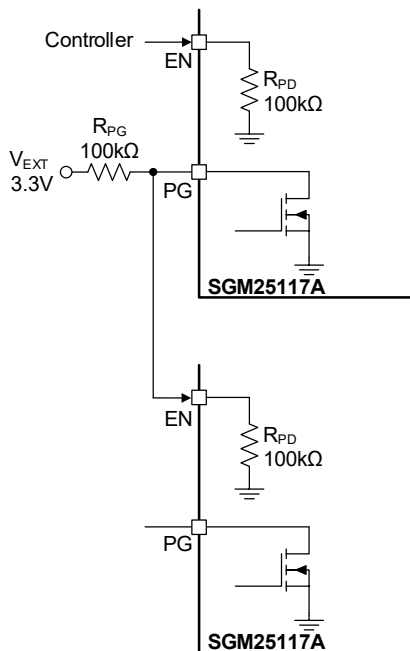

Figure 6. Power Sequencing with PG Output

FUNCTIONAL BLOCK DIAGRAM

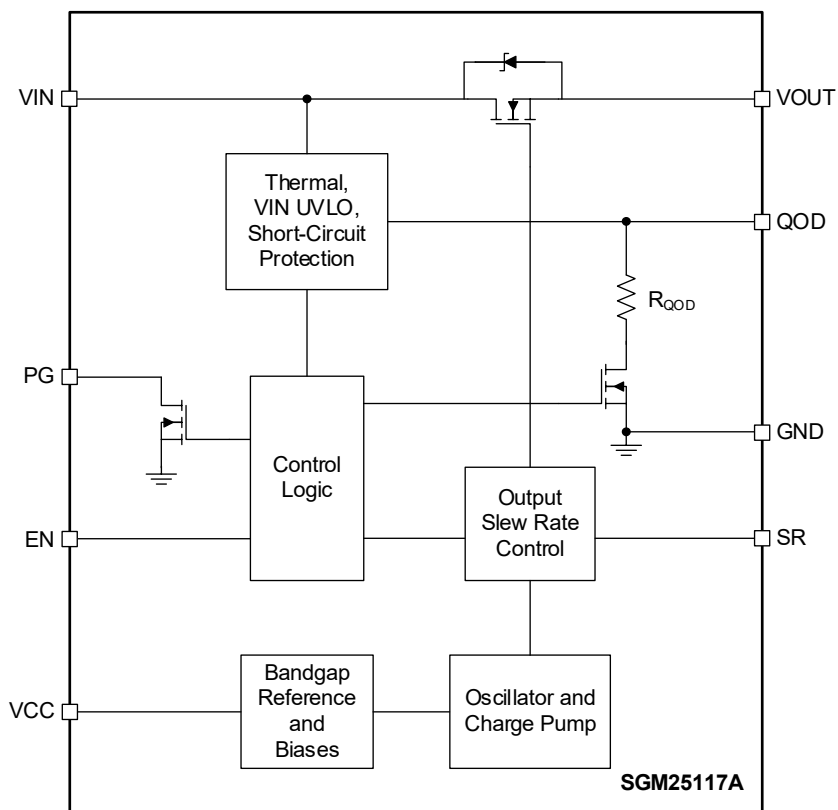

Figure 7. Block Diagram

DETAILED DESCRIPTION

Enable Control

The SGM25117A allows the MOSFET to be enabled when EN pin is pulled to high level. The MOSFET will be turned on when the VCC and VIN pins have a high enough voltage and the EN pin is connected to high level. If the EN pin is connected to low level, the MOSFET will be turned off. EN has an internal pull-down resistor to ground which can ensure the MOSFET will not be turned on when it is disabled.

Power Sequencing

The output turn-on delay performance of the SGM25117A may vary with different power-on sequences. The following two recommended power-on sequences can achieve the specified performance:

- ◆ $V_{CC} \rightarrow V_{IN} \rightarrow V_{EN}$
- ◆ $V_{IN} \rightarrow V_{CC} \rightarrow V_{EN}$

When the VCC pin voltage is higher than 2.6V, the enable control of the EN pin can operate correctly. The enable signal may not take effect unless EN is pulled high after VCC reaches 2.6V.

Quick Output Discharge (QOD)

The R_{QOD} is an integrated discharge resistor. When the MOSFET is turned off, the R_{QOD} will discharge the load charge to ground. The discharge resistor is in series with a discharge switch. Once the MOSFET is turned off, the discharge switch will be turned on and the R_{QOD} starts to take effect. Only one of the MOSFET and the discharge switch is working at the same time.

The QOD pin and the VOUT pin can be connected together directly as shown in Figure 5. These two pins can also be connected through an external resistor (R_{EXT}) as shown in Figure 4. R_{EXT} should be less than 1k Ω . The R_{QOD} plus the R_{EXT} is the total discharge resistance.

Power Good

The SGM25117A has a PG flag pin which will be set high when the gate of the MOSFET is fully charged. The PG pin uses an active-high, open-drain output. The external pull-up resistor (R_{PG}) needs to be connected to an external voltage source (V_{EXT}), (see Figure 4 and

Figure 5). The R_{PG} should not be less than 1k Ω . The V_{EXT} can be compatible with input levels of other devices connected to this pin.

The PG output can be connected to EN pin of other active-high devices in the whole system (see Figure 4). This can achieve the specific power-on sequence without the additional enable signals from the system controller. The PG pin needs to be connected to GND if the PG feature is not required.

Slew Rate Control

The SGM25117A can be configured with different output slew rate during the soft-start which can suppress the inrush current caused by charging of output capacitor. This makes the device very suitable for hot-swap applications.

The SGM25117A device achieves the different output slew rate during soft-start through the capacitor between SR pin and GND. Equation 1 can be used to calculate the slew rate:

$$\text{Slew Rate} = \frac{K_{SR}}{C_{SR}} \text{ (V/s)} \quad (1)$$

where:

K_{SR} is slew rate control constant.

C_{SR} is the external capacitor of the SR pin.

The slew rate can not be configured to exceed the default slew rate. If the C_{SR} is not large enough, the slew rate can't be less than the default value and the device will keep the default slew rate during the soft-start. If it doesn't require a smaller slew rate, the SR pin should keep in floating.

Short-Circuit Protection

The SGM25117A device is integrated with short-circuit protection which can prevent the damage of the device and the system caused by a sudden high current when output is shorted to GND. The short-circuit protection will not be enabled until the gate of the MOSFET is fully charged.

DETAILED DESCRIPTION (continued)

The device detects the voltage drop between VIN and QOD pins to realize the short-circuit protection. In order to detect output voltage through the QOD pin, the QOD pin and the VOUT pin can be connected together directly in Figure 5 or through an external resistor (R_{EXT}) in Figure 4. R_{EXT} should be less than 1k Ω . With this connection, the device can detect the voltage drop between the two terminals of the MOSFET for short-circuit protection.

Once the voltage drop between the two terminals of the MOSFET exceeds the short-circuit protection threshold, the MOSFET is disabled immediately and discharge switch is enabled. The device will latch up once short-circuit protection is triggered and can not exit the off-state unless the EN or VCC restarts. The restart also follows the specific output turn-on delay and slew rate. The load current that triggers the short-circuit protection can be calculated which is the short-circuit protection threshold divided by the $R_{DS(ON)}$ of MOSFET.

The SGM25117A device does not support short-circuit startup.

Thermal Shutdown

The SGM25117A is a device integrated with thermal shutdown feature which can prevent the device from the overheating damage. Once the device detects the over-temperature condition, the MOSFET is disabled immediately and the discharge switch starts to work. When the EN pin is connected to low level, the thermal shutdown circuitry is disabled to reduce the standby current.

When the junction temperature drops to the value of the thermal shutdown threshold minus the thermal hysteresis, the device will exit the thermal shutdown state. When the thermal shutdown state is released and the EN is still enabled, the MOSFET will go back to work again. The restart also follows the specific output turn-on delay and slew rate.

Under-Voltage Lockout

The SGM25117A is a device integrated with under-voltage lockout feature. When the input voltage (V_{IN}) drops to under-voltage lockout threshold ($V_{UVLO(L)}$), the MOSFET is disabled and the discharge switch starts to work. When the EN pin is connected to low level, the under-voltage lockout circuitry is shut down to reduce the standby current.

When the input voltage exceeds the under-voltage lockout high level threshold ($V_{UVLO(H)}$) and the EN is still enabled, the under-voltage lockout will be released and the MOSFET will be switched on. The restart also follows the specific output turn-on delay and slew rate.

Capacitive Load

The maximum inrush current caused by charging of output capacitive load should be less than the specified I_{MAX} . The maximum C_L can be calculated by following equation:

$$C_{MAX} = \frac{I_{MAX}}{SR_{TYP}} \quad (2)$$

where:

I_{MAX} is the load current (max).

SR_{TYP} is the default slew rate with no additional external capacitor on SR pin.

Off to On Transition Energy Dissipation

During the steady state operation, because of the low $R_{DS(ON)}$, the conduction loss of the MOSFET caused by the load current is very small. Once the EN is enabled, the MOSFET immediately switches from off-state to on-state and correspondingly, the impedance between VIN and VOUT switches from the high impedance to $R_{DS(ON)}$. Therefore, the additional energy dissipation during this short period of time should be considered. The maximum energy dissipation during the transition from off-state to on-state can be calculated according to the following equation:

$$E = 0.5 \times V_{IN} \times (I_{INRUSH} + I_{LOAD}) \times t_R \quad (3)$$

where:

V_{IN} is the input voltage which means the voltage of VIN pin.

I_{INRUSH} is the inrush current caused by output capacitive load.

I_{LOAD} is the load current.

t_R is the rising time of output voltage (0V to V_{OUT}).

I_{INRUSH} can be calculated according to the following equation:

$$I_{INRUSH} = \frac{dV}{dt} \times C_L \quad (4)$$

where:

dV/dt is the configured output slew rate.

C_L is the output capacitive load.

For security, the energy dissipation during the transition from off-state to on-state should not exceed E_{TRANS} defined in the operating ranges table.

DETAILED DESCRIPTION (continued)

Electrical Layout Considerations

Physical PCB layout should be considered carefully because the correct layout has the advantage of low noise and accurate operation of the load switch.

Power Planes: the load switch has an extremely low R_{DS(ON)} in consideration of low power consumption. However, improper PCB layout may cause a large parasitic series resistance from source to load. For low series resistance and good heat dissipation, the VIN pin and VOUT pin of load switch should be firmly

connected to the copper plane. The load switch requires sufficient heat dissipation to avoid unexpected thermal shutdown. In the short period of time following the rising edge of the enable signal, the MOSFET needs to dissipate an amount of power depended on load condition. Therefore, it is very critical to design a good thermal conduction path from the packaging to the board. Make sure that there is no direct coupling between VIN and VOUT, which may adversely affect output slew rate.

REVISION HISTORY

NOTE: Page numbers for previous revisions may differ from page numbers in the current version.

JUNE 2026 – REV.A to REV.A.1	Page
Updated Detailed Description section	13

Changes from Original (AUGUST 2024) to REV.A	Page
Changed from product preview to production data.....	All

PACKAGE OUTLINE DIMENSIONS

TDFN-3x3-12AL

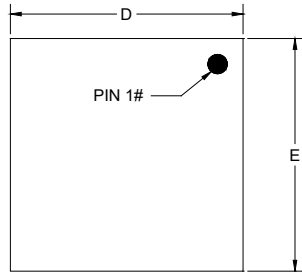

TOP VIEW

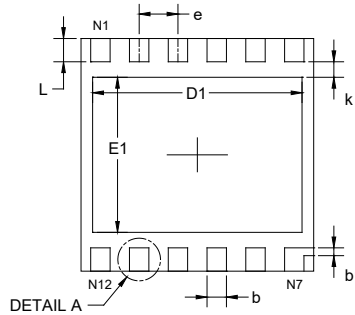

BOTTOM VIEW

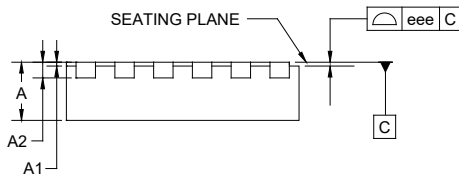

SIDE VIEW

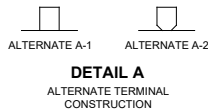

DETAIL A
ALTERNATE TERMINAL
CONSTRUCTION

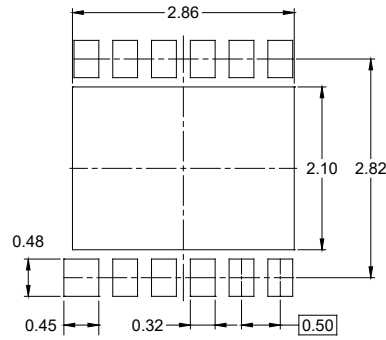

RECOMMENDED LAND PATTERN (Unit: mm)

Symbol	Dimensions In Millimeters		
	MIN	NOM	MAX
A	0.700	-	0.800
A1	0.000	-	0.050
A2	0.203 REF		
D	2.900	-	3.100
E	2.900	-	3.100
D1	2.600	-	2.800
E1	1.900	-	2.100
b	0.200	-	0.300
b1	0.100 REF		
L	0.200	-	0.400
k	0.200 REF		
e	0.500 BSC		
eee	0.080		

NOTE: This drawing is subject to change without notice.

TAPE AND REEL INFORMATION

REEL DIMENSIONS

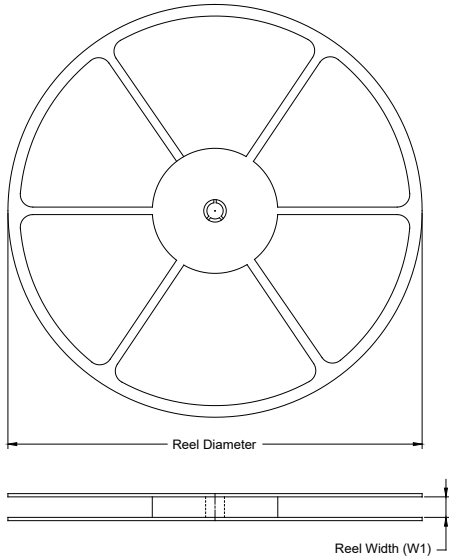

TAPE DIMENSIONS

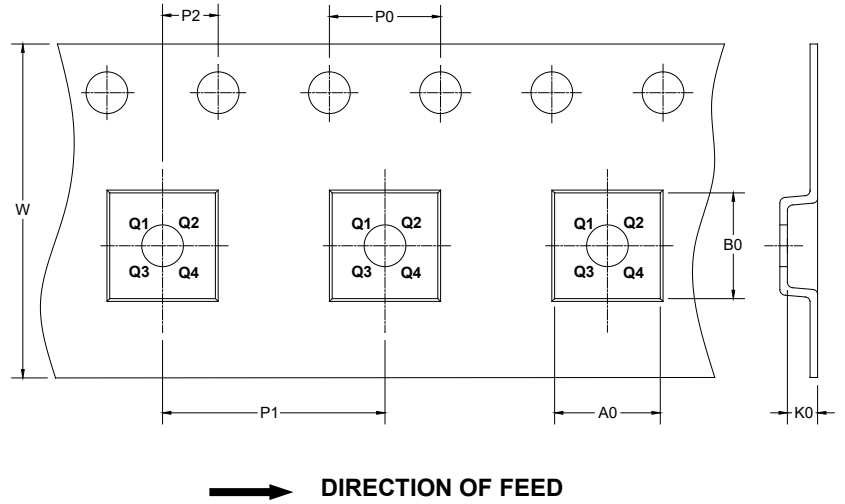

NOTE: The picture is only for reference. Please make the object as the standard.

KEY PARAMETER LIST OF TAPE AND REEL

Package Type	Reel Diameter	Reel Width W1 (mm)	A0 (mm)	B0 (mm)	K0 (mm)	P0 (mm)	P1 (mm)	P2 (mm)	W (mm)	Pin1 Quadrant
TDFN-3×3-12AL	13"	12.4	3.35	3.35	1.13	4.0	8.0	2.0	12.0	Q2

DD0001

PACKAGE INFORMATION

CARTON BOX DIMENSIONS

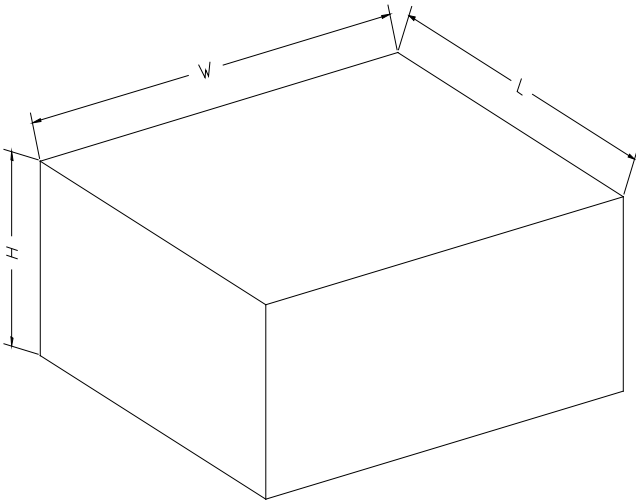

NOTE: The picture is only for reference. Please make the object as the standard.

KEY PARAMETER LIST OF CARTON BOX

Reel Type	Length (mm)	Width (mm)	Height (mm)	Pizza/Carton
13"	386	280	370	5

DD0002