

### GENERAL DESCRIPTION

The SGM8257A-1 is a single, high voltage operational amplifier with high output drive capability. It can operate from 10V to 70V single supply or from  $\pm 5V$  to  $\pm 35V$  dual power supplies. The high voltage SGM8257A-1 provides a wide input common mode voltage range and output voltage swing without phase inversion. The device is also capable of delivering a relatively high output current of  $\pm 50mA$ . It offers a gain-bandwidth product of 2.8MHz and can keep unity-gain stable in applications.

The SGM8257A-1 includes built-in over-current and over-temperature protections. These conditions are monitored via the Status Flag pin, which is an open-drain output. When either condition occurs, the Status Flag pin goes active, alerting the system to take protective measures.

Additionally, the SGM8257A-1 features a disable function. The E/D pin can enable or disable the output stage independently without affecting input signal transmission. The E/D COM pin serves as a common return, simplifying the connection of the E/D pin to low-voltage logic circuits. The disable function helps reduce power consumption and protects the load when the amplifier output is not needed.

The SGM8257A-1 is available in a Green SOIC-8 (Exposed Pad) package. It is specified from  $-40^{\circ}C$  to  $+125^{\circ}C$  temperature range.

### FEATURES

- **Support Single or Dual Power Supplies:**  
10V to 70V or  $\pm 5V$  to  $\pm 35V$
- **High Output Current:  $\pm 50mA$**
- **Wide Output Voltage Swing:**  
 $(-V_S) + 1V$  to  $(+V_S) - 1V$
- **Independent Disable Function**
- **Over-Current Protection**
- **Over-Temperature Protection**
- **$-40^{\circ}C$  to  $+125^{\circ}C$  Operating Temperature Range**
- **Available in a Green SOIC-8 (Exposed Pad) Package**

### APPLICATIONS

- Test Equipment
- Medical Equipment
- Current Sensing
- Drivers of Piezoelectric Cells
- Transducer Drivers
- Servo Applications

### SIMPLIFIED SCHEMATIC

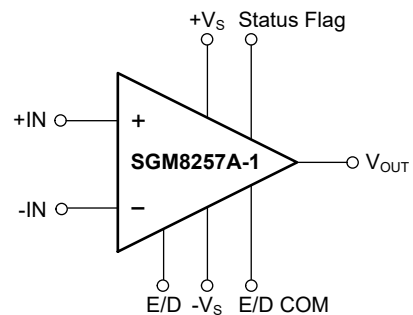

Figure 1. Simplified Schematic

**PACKAGE/ORDERING INFORMATION**

MODEL	PACKAGE DESCRIPTION	SPECIFIED TEMPERATURE RANGE	ORDERING NUMBER	PACKAGE MARKING	PACKING OPTION
SGM8257A-1	SOIC-8 (Exposed Pad)	-40°C to +125°C	SGM8257A-1XPS8G/TR	SGM 2L6XPS8 XXXXX	Tape and Reel, 4000

**MARKING INFORMATION**

NOTE: XXXXX = Date Code, Trace Code and Vendor Code.

**XXXXX**

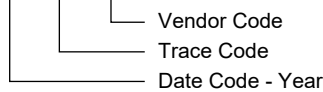

Green (RoHS & HSF): SG Micro Corp defines "Green" to mean Pb-Free (RoHS compatible) and free of halogen substances. If you have additional comments or questions, please contact your SGMICRO representative directly.

**ABSOLUTE MAXIMUM RATINGS**

- Supply Voltage, +V<sub>S</sub> to -V<sub>S</sub> ..... 100V
- Signal Input Voltage Terminals  
..... (-V<sub>S</sub>) - 0.3V to (+V<sub>S</sub>) + 0.3V
- Voltage, E/D to E/D COM ..... 5.5V
- Signal Input Current Terminals ..... ±10mA
- Output Short-Circuit Current <sup>(1)</sup> ..... Continuous
- Package Thermal Resistance  
SOIC-8 (Exposed Pad), θ<sub>JA</sub>..... 34.2°C/W
- SOIC-8 (Exposed Pad), θ<sub>JB</sub>..... 11.4°C/W
- SOIC-8 (Exposed Pad), θ<sub>JC (TOP)</sub> ..... 45.4°C/W
- SOIC-8 (Exposed Pad), θ<sub>JC (BOT)</sub> ..... 2.5°C/W
- Package Thermal Characterization Parameter  
SOIC-8 (Exposed Pad), ψ<sub>JT</sub>..... 2.3°C/W
- SOIC-8 (Exposed Pad), ψ<sub>JB</sub>..... 11°C/W
- Junction Temperature ..... +150°C
- Storage Temperature Range ..... -65°C to +150°C
- Lead Temperature (Soldering, 10s) ..... +260°C
- ESD Susceptibility <sup>(2) (3)</sup>
- HBM ..... ±4000V
- CDM ..... ±1000V

**NOTES:**

1. Short-circuit to ground.
2. For human body model (HBM), all pins comply with ANSI/ESDA/JEDEC JS-001 specifications.
3. For charged device model (CDM), all pins comply with ANSI/ESDA/JEDEC JS-002 specifications.

**RECOMMENDED OPERATING CONDITIONS**

- Supply Voltage Range, +V<sub>S</sub> to -V<sub>S</sub>.....  
..... 10V to 70V or ±5V to ±35V
- Operating Temperature Range ..... -40°C to +125°C

**OVERSTRESS CAUTION**

Stresses beyond those listed in Absolute Maximum Ratings may cause permanent damage to the device. Exposure to absolute maximum rating conditions for extended periods may affect reliability. Functional operation of the device at any conditions beyond those indicated in the Recommended Operating Conditions section is not implied.

**ESD SENSITIVITY CAUTION**

This integrated circuit can be damaged if ESD protections are not considered carefully. SGMICRO recommends that all integrated circuits be handled with appropriate precautions. Failure to observe proper handling and installation procedures can cause damage. ESD damage can range from subtle performance degradation to complete device failure. Precision integrated circuits may be more susceptible to damage because even small parametric changes could cause the device not to meet the published specifications.

**DISCLAIMER**

SG Micro Corp reserves the right to make any change in circuit design, or specifications without prior notice.

**PIN CONFIGURATION**

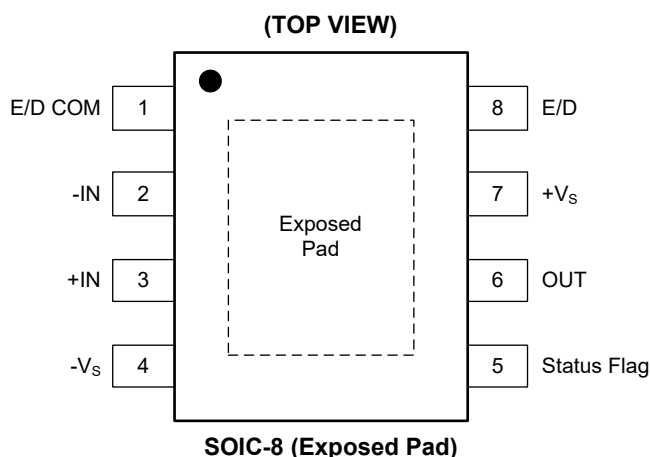

**PIN DESCRIPTION**

PIN	NAME	FUNCTION
1	E/D COM	Enable/Disable Common. This pin is typically connected to a reference voltage or ground and serves as the reference level for the E/D pin.
2	-IN	Inverting Input.
3	+IN	Non-Inverting Input.
4	-Vs	Negative Power Supply.
5	Status Flag	Active-Low Open-Drain Output Referenced to the E/D COM. When either over-temperature or over-current condition occurs, the Status Flag pin goes active, alerting the system to take protective measures.
6	OUT	Output.
7	+Vs	Positive Power Supply.
8	E/D	Enable/Disable. When the E/D pin is left floating, the operational amplifier is enabled by default. To disable the operational amplifier, connect the E/D pin to a low logic level.
Exposed Pad	-Vs	Connect the exposed pad to -Vs. The exposed pad must always be soldered to the PCB, even in applications with minimal power dissipation.

# High Voltage, High Current, SGM8257A-1 Unity-Gain Stable, Operational Amplifier

## ELECTRICAL CHARACTERISTICS

( $V_S = \pm 35V$ ,  $V_{CM} = V_{OUT} = \text{mid-supply}$ ,  $R_L = 4.8k\Omega$  to mid-supply, maximum and minimum values are at  $T_A = -40^\circ C$  to  $+125^\circ C$ , typical values are at  $T_A = +25^\circ C$ , unless otherwise noted.)

PARAMETER	SYMBOL	CONDITIONS	MIN	TYP	MAX	UNITS
<b>Input Characteristics</b>						
Input Offset Voltage	$V_{OS}$	$I_{OUT} = 0mA$		$\pm 0.1$	$\pm 1.5$	mV
Input Offset Voltage Drift <sup>(1)</sup>	$\Delta V_{OS}/\Delta T$	$T_A = -40^\circ C$ to $+125^\circ C$		$\pm 2.5$	$\pm 6$	$\mu V/^\circ C$
Input Offset Voltage vs. Power Supply	PSRR	$V_S = \pm 5V$ to $\pm 35V$ , $V_{CM} = 0V$		$\pm 3$	$\pm 20$	$\mu V/V$
Input Bias Current	$I_B$	$T_A = +25^\circ C$		$\pm 100$	$\pm 600$	pA
Input Offset Current	$I_{OS}$	$T_A = +25^\circ C$		$\pm 100$	$\pm 650$	pA
Input Common Mode Voltage Range	$V_{CM}$	Linear operation	$(-V_S) + 2.5$		$(+V_S) - 2.5$	V
Common Mode Rejection Ratio	CMRR	$-10V \leq V_{CM} \leq 10V$	100	134		dB
		$-30V \leq V_{CM} \leq 30V$	100	146		
Open-Loop Voltage Gain	$A_{OL}$	$(-V_S) + 1V < V_{OUT} < (+V_S) - 1V$ , $R_L = 49k\Omega$ , $I_{OUT} = \pm 0.7mA$	100	134		dB
		$(-V_S) + 1V < V_{OUT} < (+V_S) - 2V$ , $R_L = 4.8k\Omega$ , $I_{OUT} = \pm 6.8mA$	90	134		
		$(-V_S) + 2V < V_{OUT} < (+V_S) - 3V$ , $R_L = 1880\Omega$ , $I_{OUT} = \pm 17mA$	86	126		
Input Impedance	Differential			$10^{11} \parallel 6$		$\Omega \parallel pF$
	Common Mode			$10^{11} \parallel 5$		
<b>Output Characteristics</b>						
Output Voltage Swing from Rail	$V_{OUT}$	$R_L = 49k\Omega$ , $A_{OL} \geq 100dB$ , $I_{OUT} = 0.7mA$	$(-V_S) + 1$		$(+V_S) - 1$	V
		$R_L = 4.8k\Omega$ , $A_{OL} \geq 90dB$ , $I_{OUT} = 6.8mA$	$(-V_S) + 1$		$(+V_S) - 2$	
		$R_L = 1880\Omega$ , $A_{OL} \geq 86dB$ , $I_{OUT} = 17mA$	$(-V_S) + 2$		$(+V_S) - 3$	
Maximum Peak Current Output, Current Limit	$I_{OUT}$	Source		93		mA
		Sink		100		
Open-Loop Output Impedance	$R_{OUT}$	$f = 1kHz$		100		$\Omega$
Capacitive Load Drive	$C_L$			200		pF
Output Disabled		Output capacitance		25		pF
<b>Dynamic Performance</b>						
Gain-Bandwidth Product	GBP	Small-signal		2.8		MHz
Slew Rate	SR	$G = \pm 1$ , $V_{OUT} = 50V$ step, $R_L = 3.27k\Omega$		13		V/ $\mu s$
Full-Power Bandwidth				55		kHz
Settling Time <sup>(2)</sup>	To $\pm 0.1\%$	$t_s$	$G = \pm 1$ , $V_{OUT} = 20V$ step		3.5	$\mu s$
	To $\pm 0.01\%$		$G = \pm 5$ or $\pm 10$ , $V_{OUT} = 50V$ step		10	
Total Harmonic Distortion + Noise <sup>(3)</sup>	THD+N	$V_S = +35V/-35V$ , $G = \pm 1$ , $f = 1kHz$ , $V_{OUT} = 37.7V_{P-P}$		0.0005		%
<b>Noise</b>						
Input Voltage Noise		$f = 0.01Hz$ to $10Hz$		10		$\mu V_{P-P}$
Input Voltage Noise Density	$e_n$	$f = 10Hz$		250		$nV/\sqrt{Hz}$
		$f = 10kHz$		30		
Input Current Noise Density	$i_n$	$f = 1kHz$		160		$fA/\sqrt{Hz}$

### NOTES:

1. Refer to simulation and characterization tests, mass production not tested.
2. See Settling Time section for more information.
3. The supplies are decreased to permit a closer swing to rails, constrained by the limitations of the test equipment.

**ELECTRICAL CHARACTERISTICS (continued)**

( $V_S = \pm 35V$ ,  $V_{CM} = V_{OUT} = \text{mid-supply}$ ,  $R_L = 4.8k\Omega$  to mid-supply, maximum and minimum values are at  $T_A = -40^\circ\text{C}$  to  $+125^\circ\text{C}$ , typical values are at  $T_A = +25^\circ\text{C}$ , unless otherwise noted.)

PARAMETER	SYMBOL	CONDITIONS	MIN	TYP	MAX	UNITS
<b>Status Flag Pin (Referenced to E/D COM)</b>						
Output Voltage		Normal operation			E/D COM + 2	V
		$R_L = 10\Omega$ during thermal overdrive, alarm	$(+V_S) - 2.5$			
Junction Temperature	$T_J$	Alarm (Status Flag high)		150		$^\circ\text{C}$
		Return to normal operation (Status Flag low)		122		
Status Flag Delay		Enable $\rightarrow$ Disable		9		$\mu\text{s}$
		Disable $\rightarrow$ Enable		5		
		Over-current delay		25		
		Over-current recovery delay		12		
<b>E/D (Enable/Disable) Pin (Referenced to E/D COM)<sup>(4)</sup></b>						
High (Output Enabled)	$V_{SD}$	Pin open or forced high	E/D COM + 2.5		E/D COM + 5	V
Low (Output Disabled)		Pin forced low	E/D COM		E/D COM + 0.65	V
Output Disable Time				4.5		$\mu\text{s}$
Output Enable Time				4.5		$\mu\text{s}$
<b>E/D COM Pin</b>						
Voltage Range			$(-V_S)$		$(+V_S) - 5$	V
<b>Power Supply</b>						
Operating Voltage Range	$V_S$		$\pm 5$		$\pm 35$	V
Quiescent Current	$I_Q$	$I_{OUT} = 0\text{mA}$		4.1	7	mA
Quiescent Current in Shutdown Mode	$I_{SD}$	$I_{OUT} = 0\text{mA}$ , $V_{ED} = 0.65\text{V}$		200	300	$\mu\text{A}$
<b>Temperature Range</b>						
Operating Range	$T_A$		-40		125	$^\circ\text{C}$

NOTE:

4. To enable the operational amplifier, connect the E/D pin to a high logic level.

**TYPICAL PERFORMANCE CHARACTERISTICS**

At  $T_A = +25^\circ\text{C}$ ,  $V_S = \pm 35\text{V}$ , and  $R_L = 4.8\text{k}\Omega$  connected to GND, unless otherwise noted.

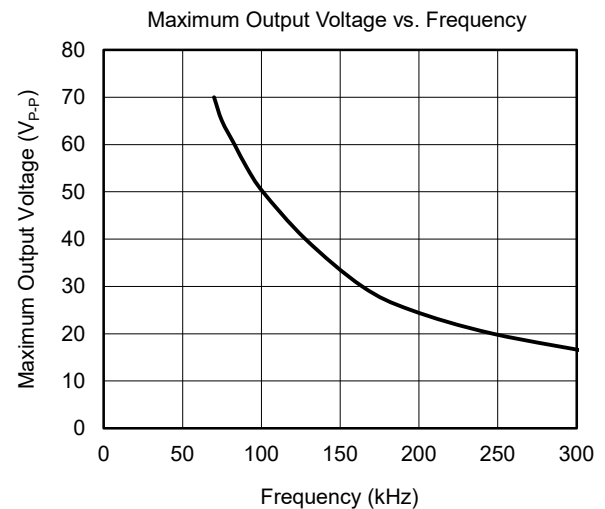
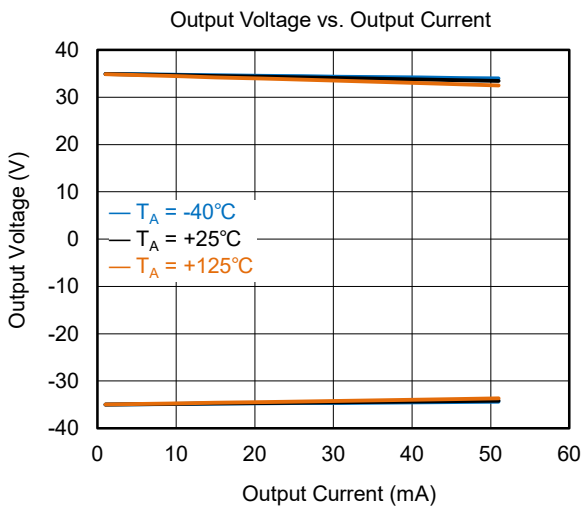
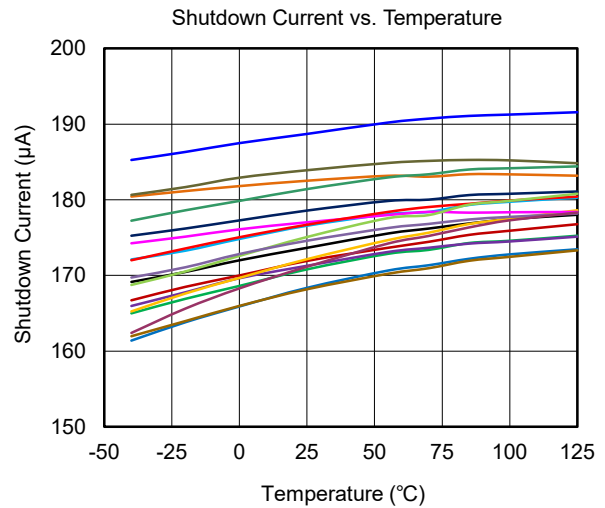
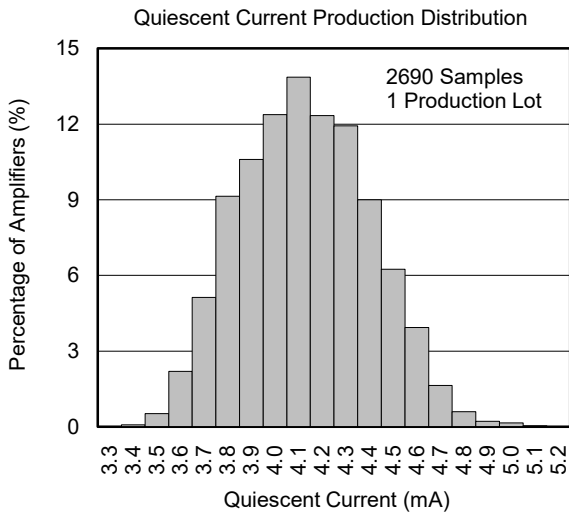
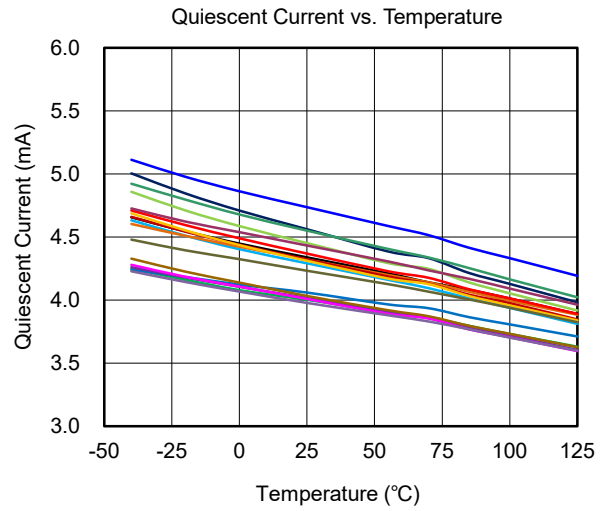
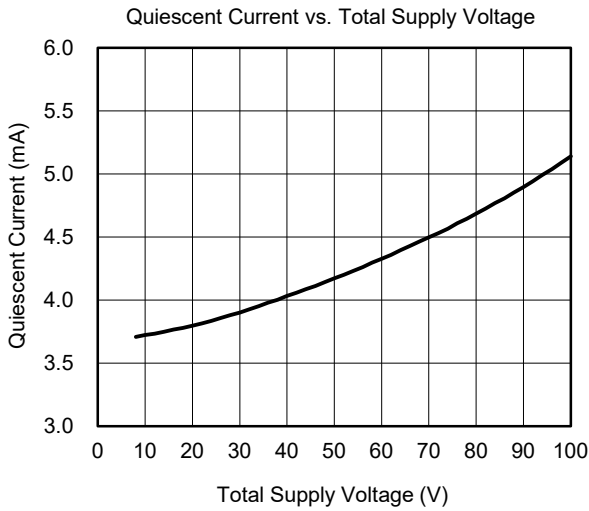

**TYPICAL PERFORMANCE CHARACTERISTICS (continued)**

At  $T_A = +25^\circ\text{C}$ ,  $V_S = \pm 35\text{V}$ , and  $R_L = 4.8\text{k}\Omega$  connected to GND, unless otherwise noted.

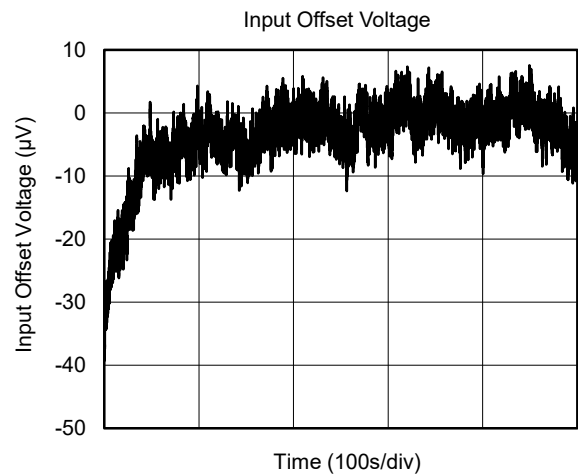
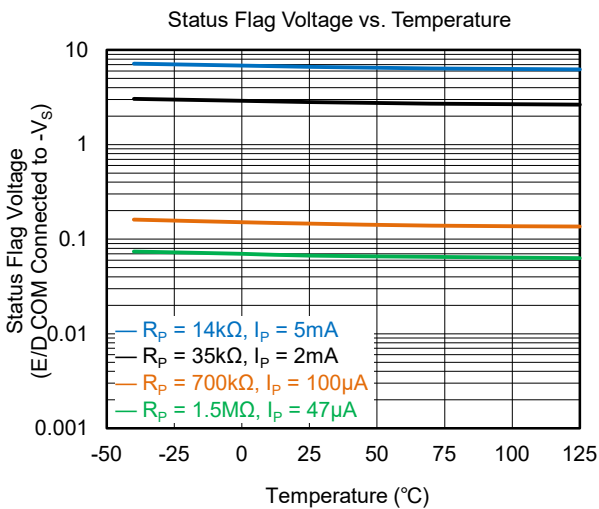
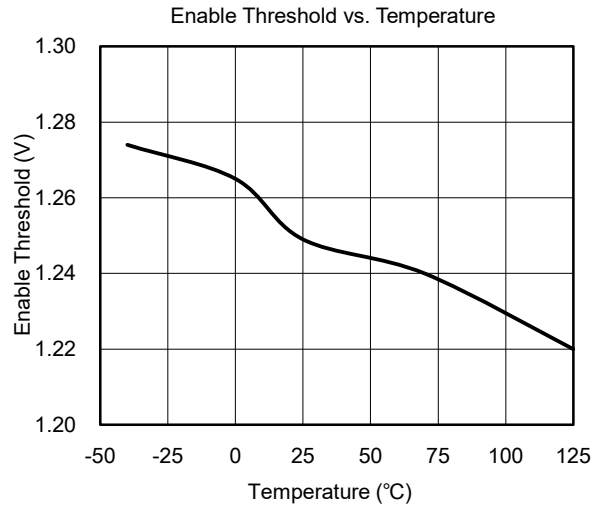
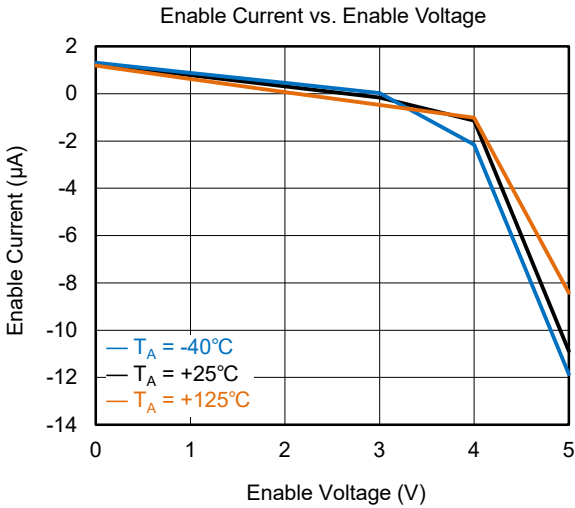
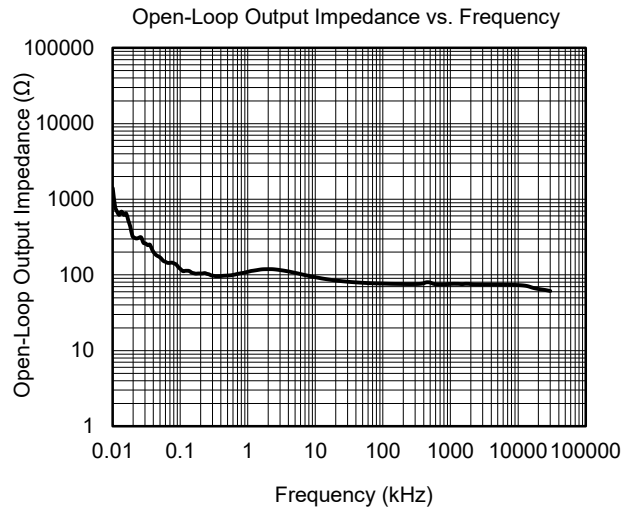
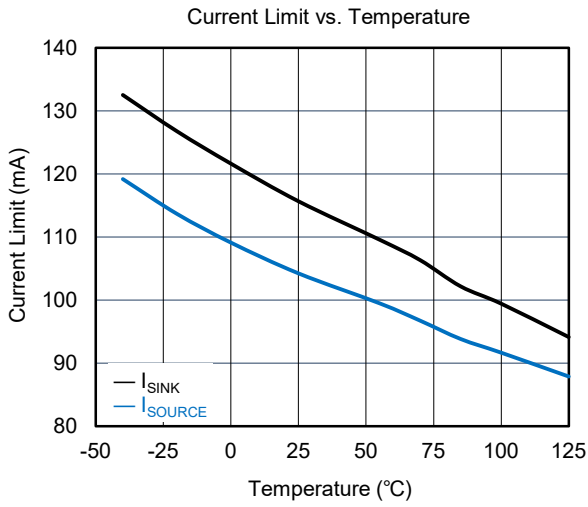

**TYPICAL PERFORMANCE CHARACTERISTICS (continued)**

At  $T_A = +25^\circ\text{C}$ ,  $V_S = \pm 35\text{V}$ , and  $R_L = 4.8\text{k}\Omega$  connected to GND, unless otherwise noted.

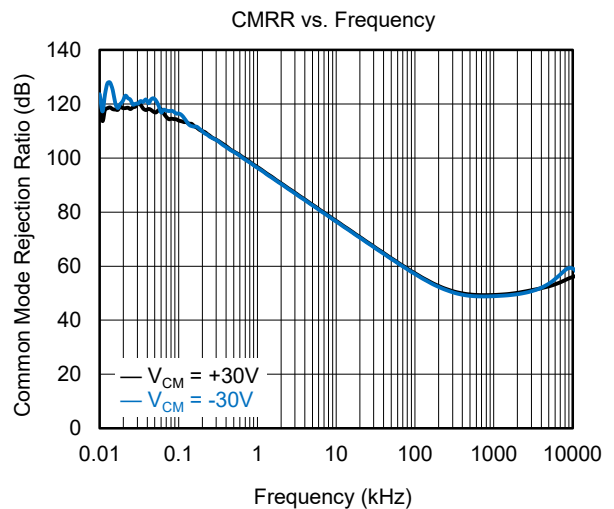
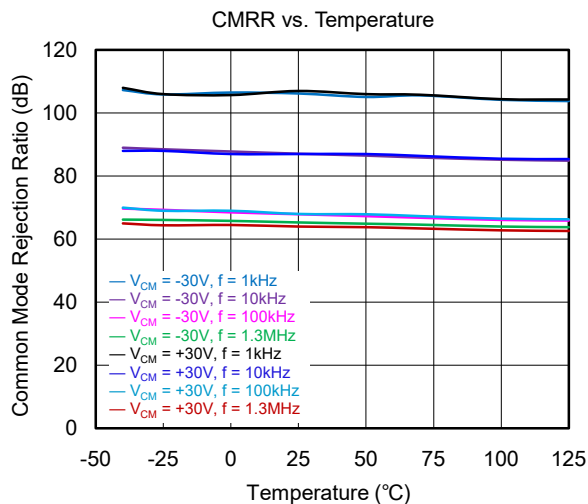
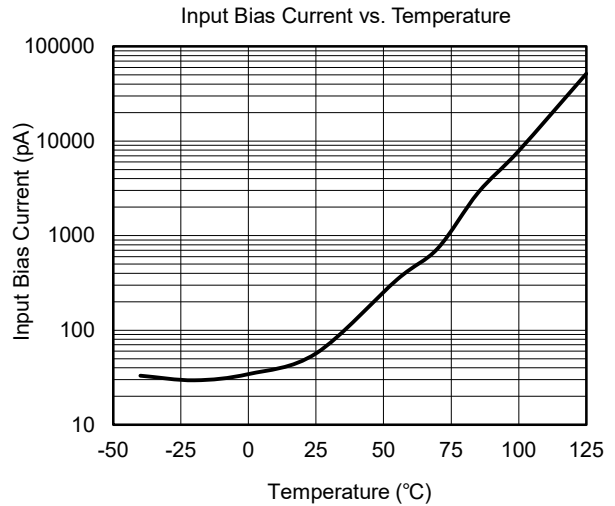
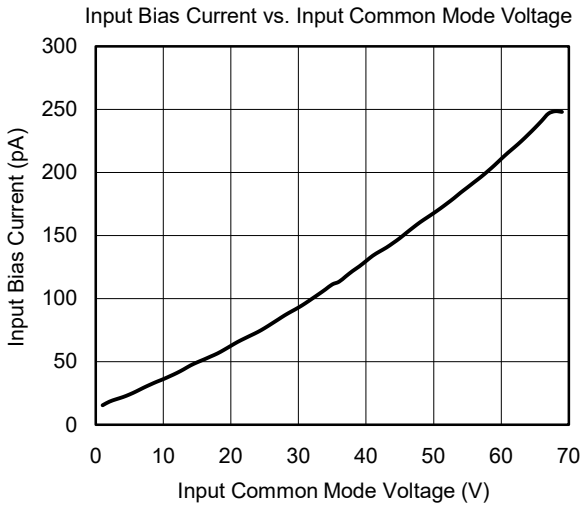
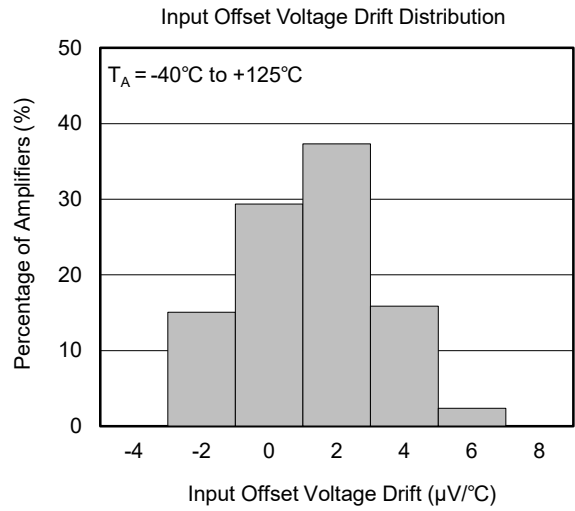
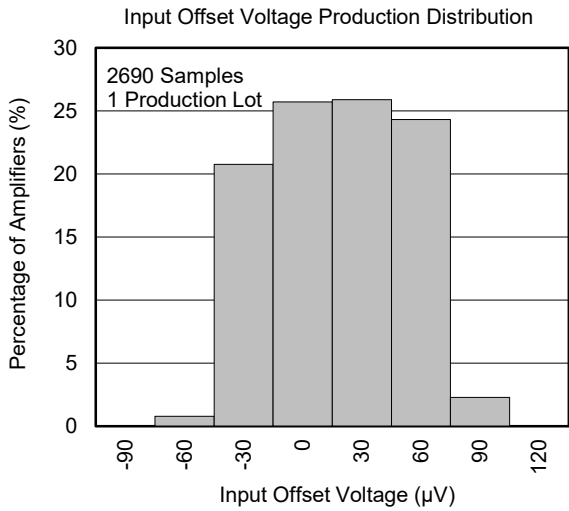

**TYPICAL PERFORMANCE CHARACTERISTICS (continued)**

At  $T_A = +25^\circ\text{C}$ ,  $V_S = \pm 35\text{V}$ , and  $R_L = 4.8\text{k}\Omega$  connected to GND, unless otherwise noted.

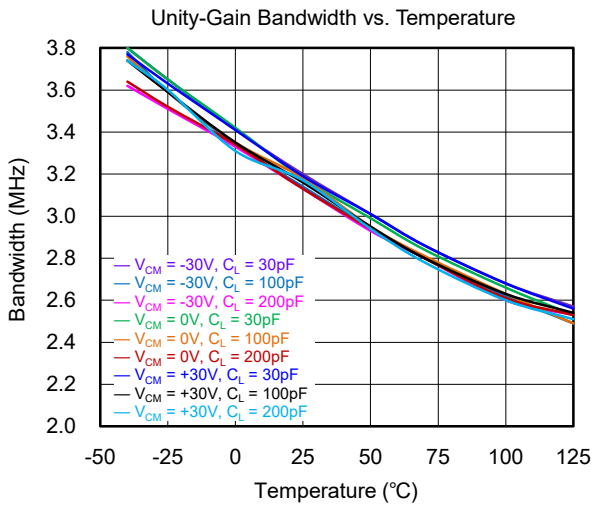
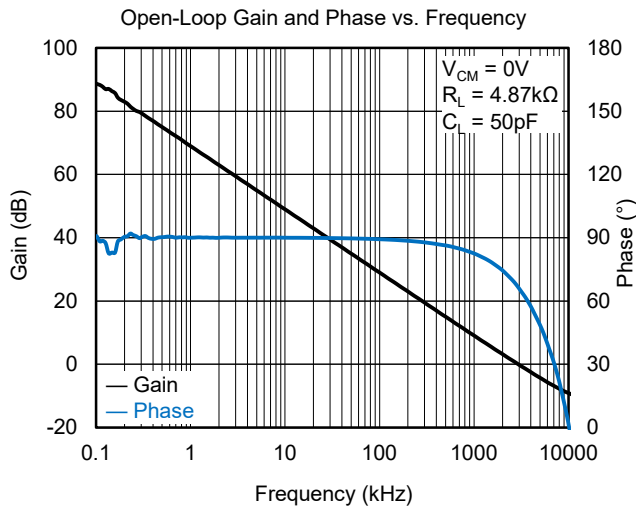
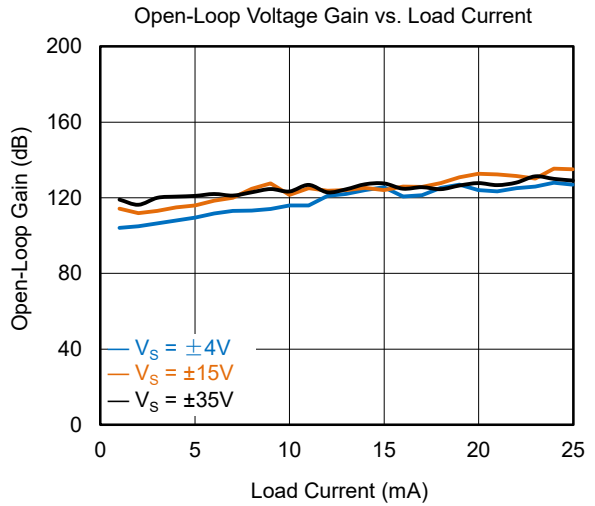
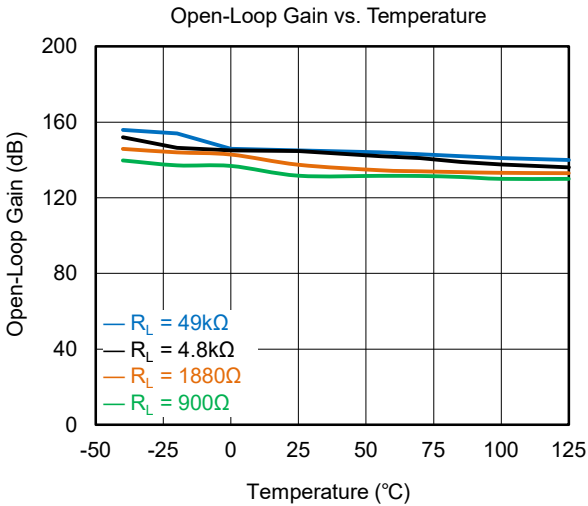
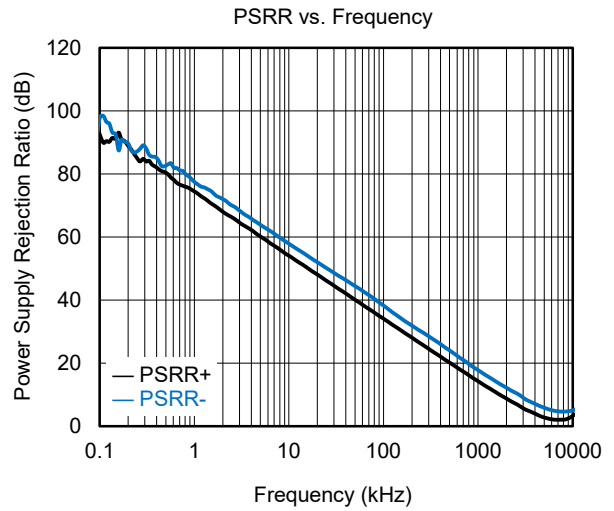
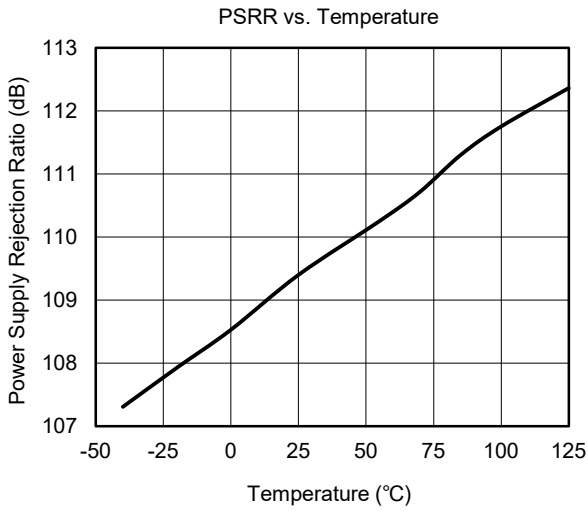

**TYPICAL PERFORMANCE CHARACTERISTICS (continued)**

At  $T_A = +25^\circ\text{C}$ ,  $V_S = \pm 35\text{V}$ , and  $R_L = 4.8\text{k}\Omega$  connected to GND, unless otherwise noted.

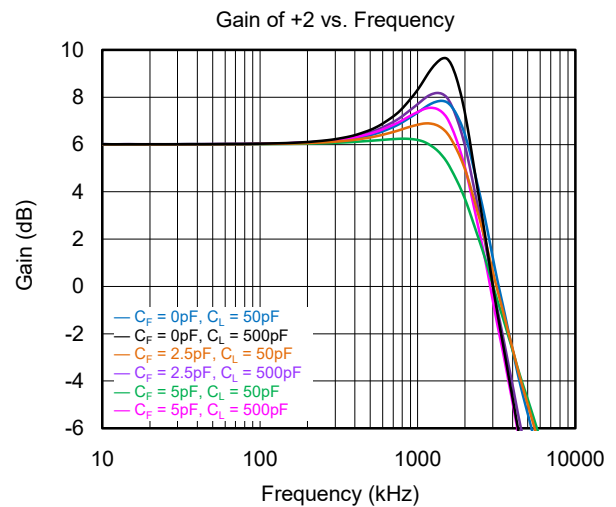
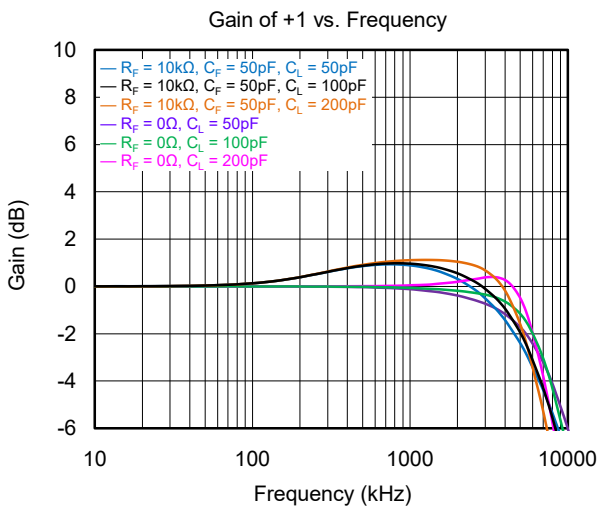
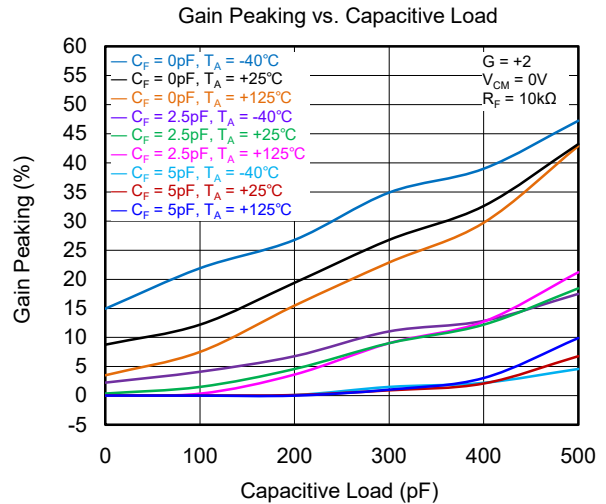
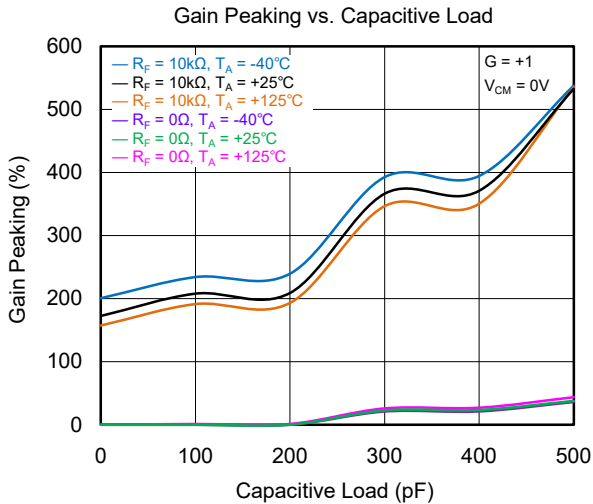
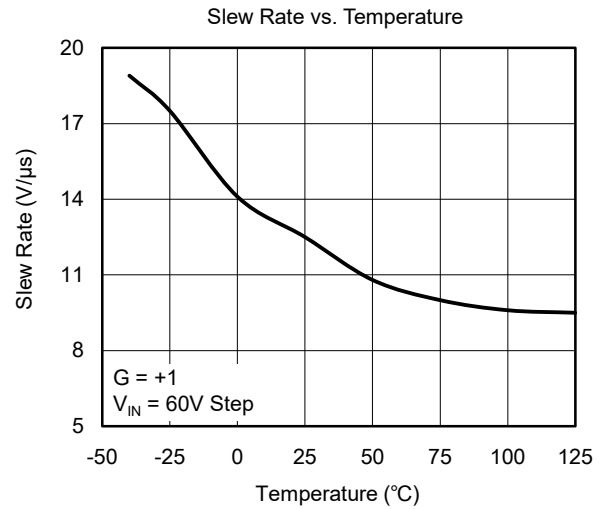
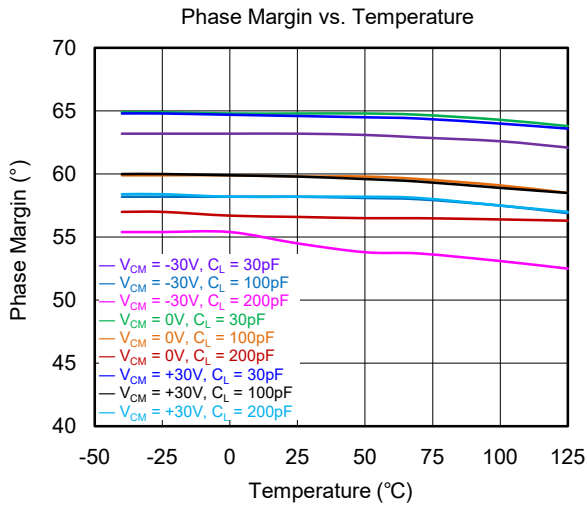

**TYPICAL PERFORMANCE CHARACTERISTICS (continued)**

At  $T_A = +25^\circ\text{C}$ ,  $V_S = \pm 35\text{V}$ , and  $R_L = 4.8\text{k}\Omega$  connected to GND, unless otherwise noted.

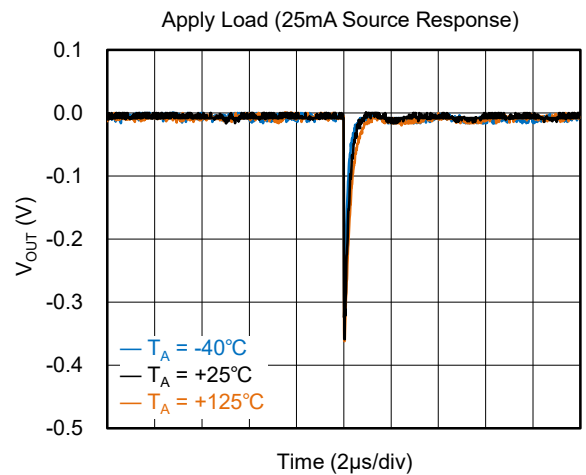
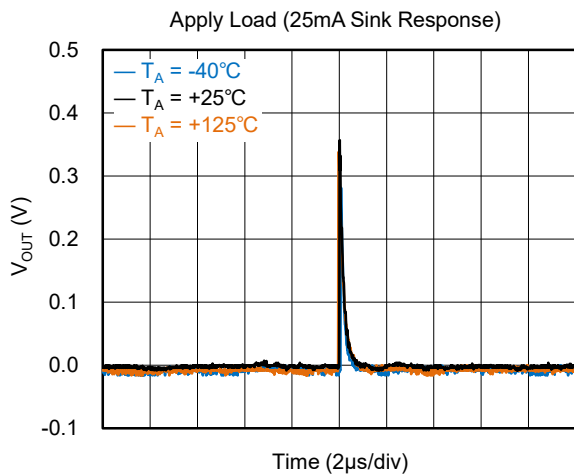
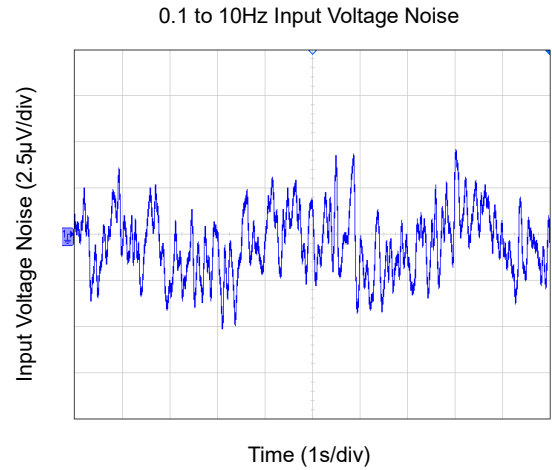
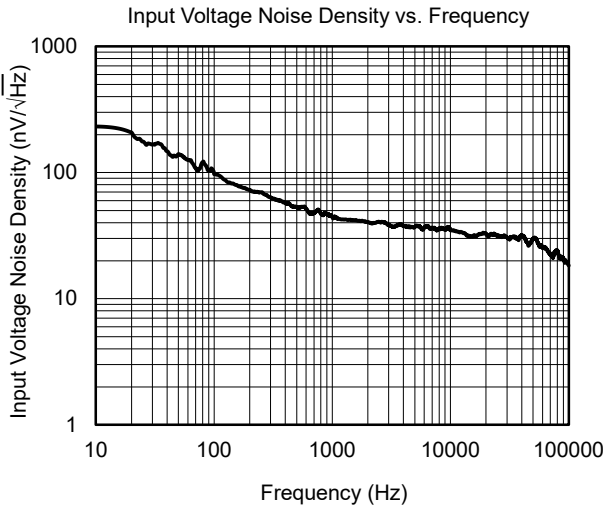
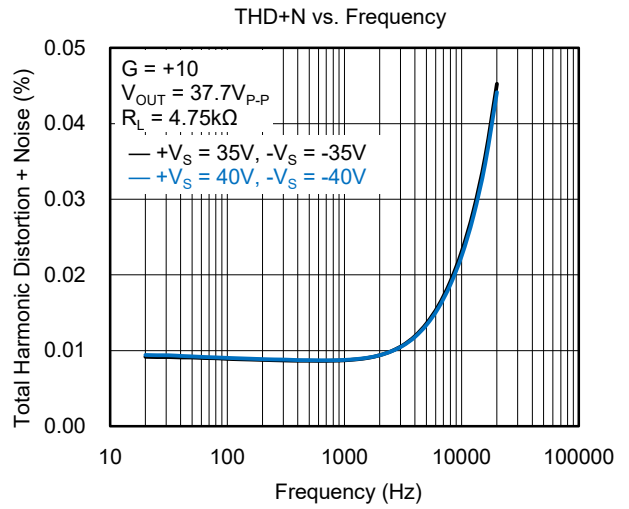
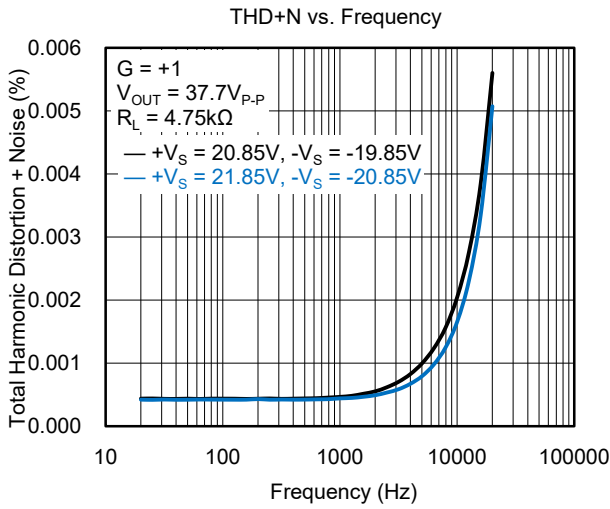

**TYPICAL PERFORMANCE CHARACTERISTICS (continued)**

At  $T_A = +25^\circ\text{C}$ ,  $V_S = \pm 35\text{V}$ , and  $R_L = 4.8\text{k}\Omega$  connected to GND, unless otherwise noted.

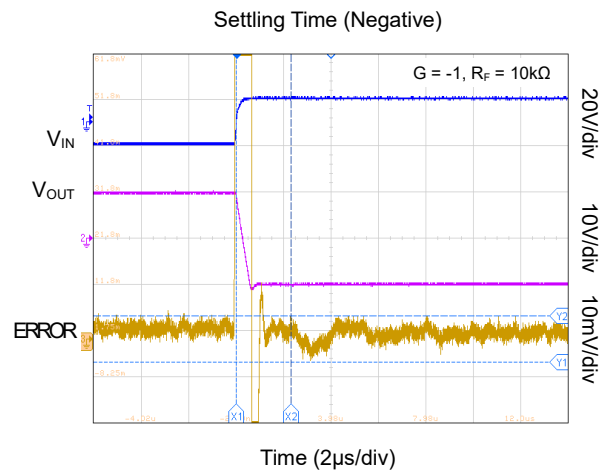
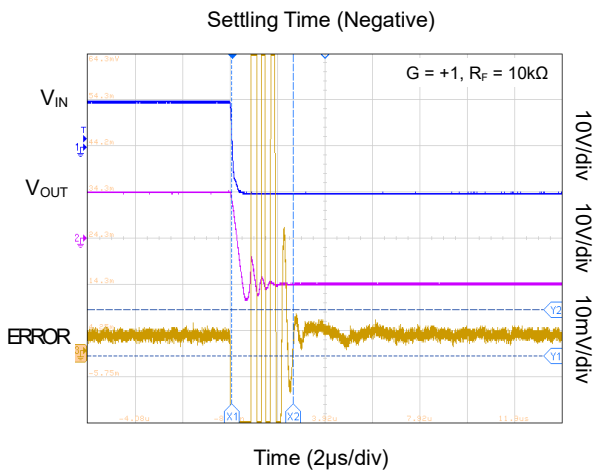
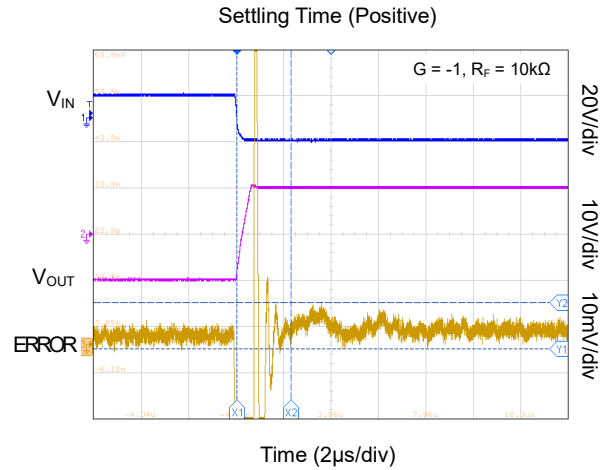
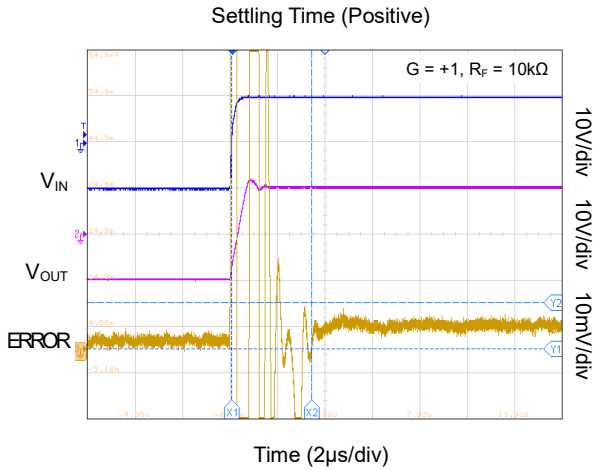
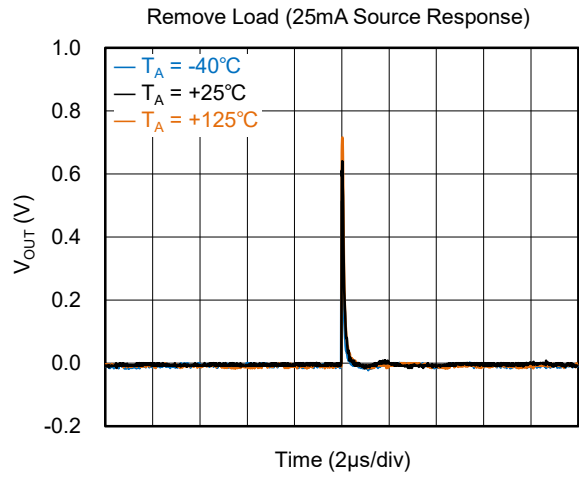
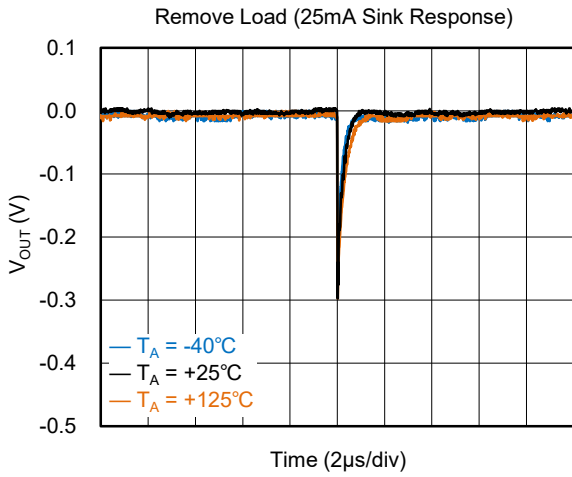

**TYPICAL PERFORMANCE CHARACTERISTICS (continued)**

At  $T_A = +25^\circ\text{C}$ ,  $V_S = \pm 35\text{V}$ , and  $R_L = 4.8\text{k}\Omega$  connected to GND, unless otherwise noted.

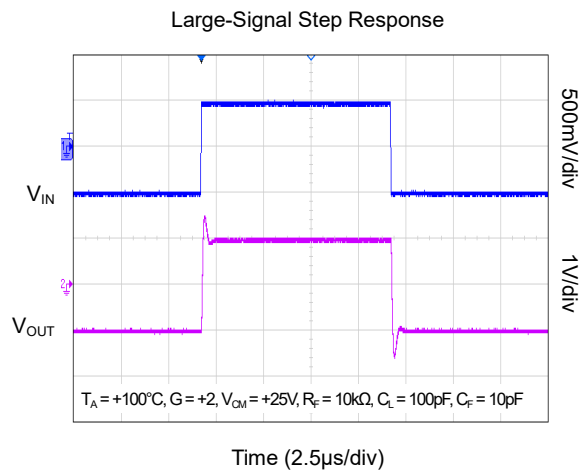
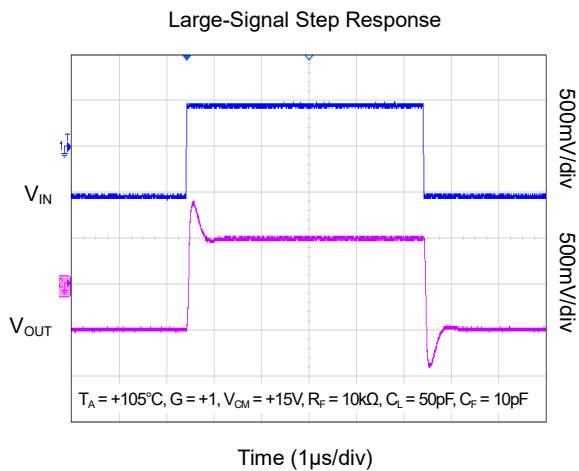
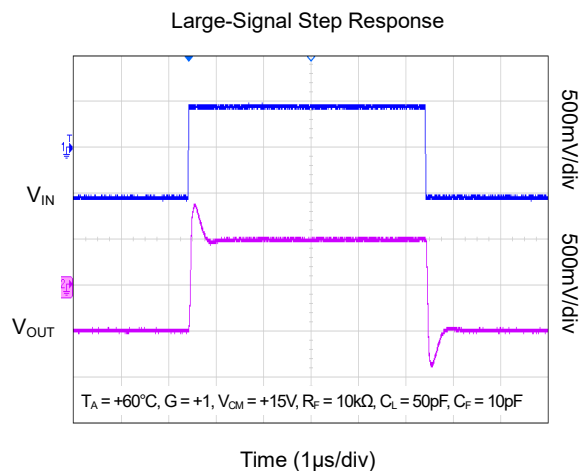
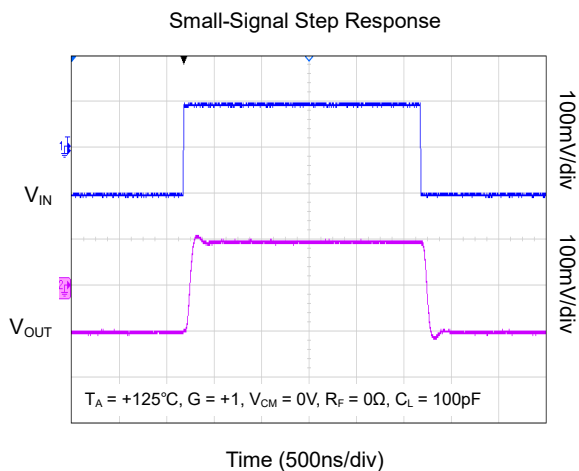
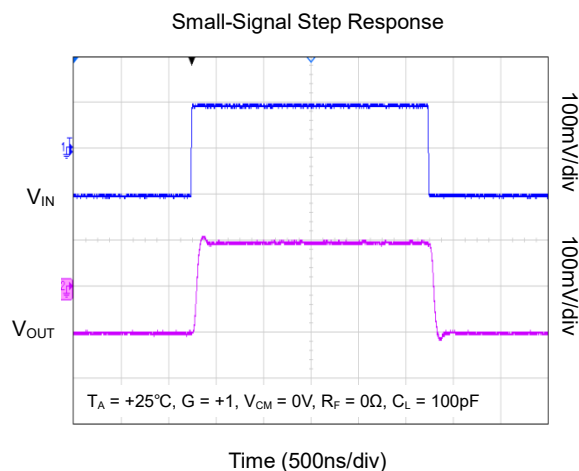
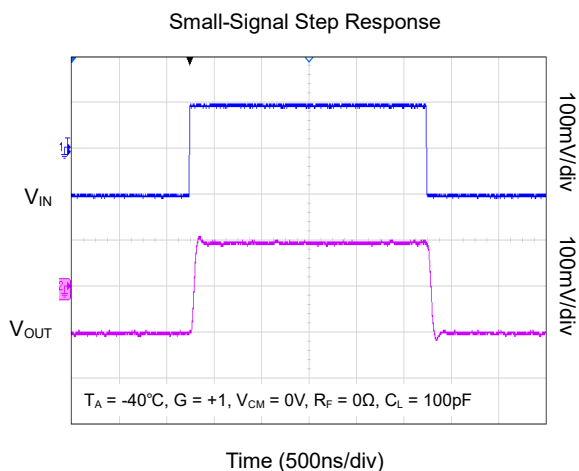

**TYPICAL PERFORMANCE CHARACTERISTICS (continued)**

At  $T_A = +25^\circ\text{C}$ ,  $V_S = \pm 35\text{V}$ , and  $R_L = 4.8\text{k}\Omega$  connected to GND, unless otherwise noted.

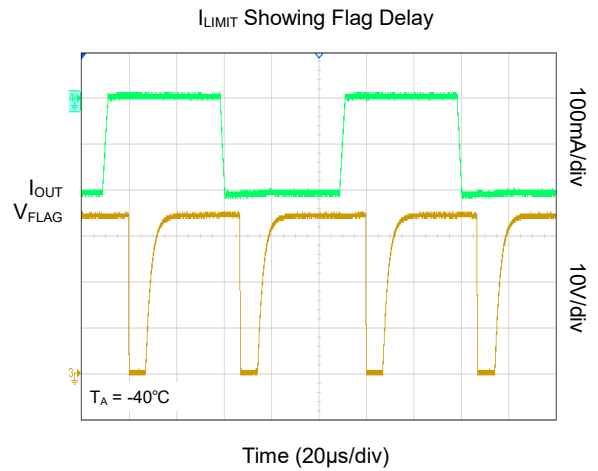
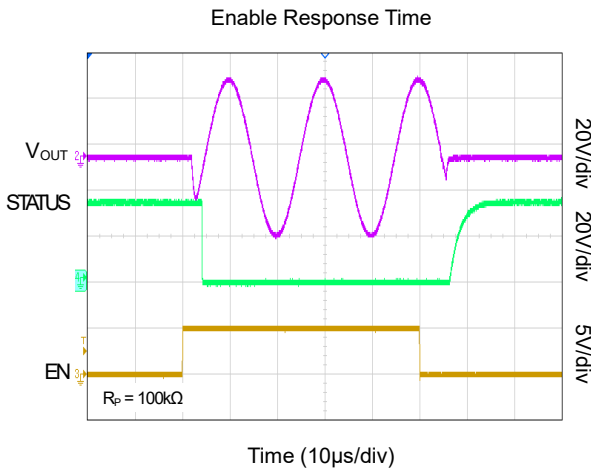
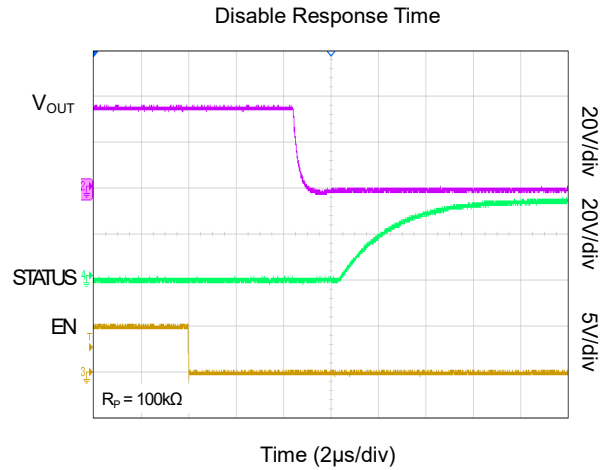
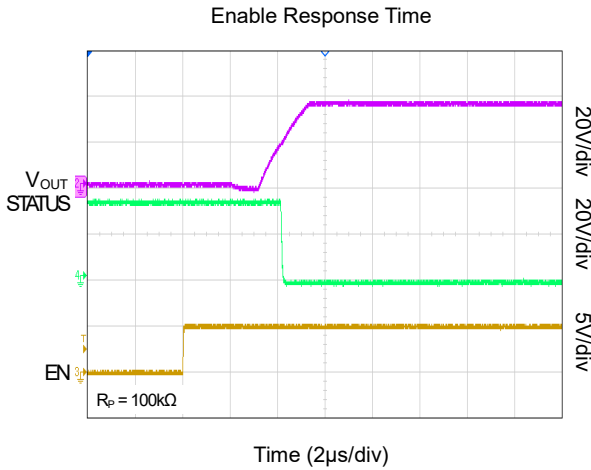
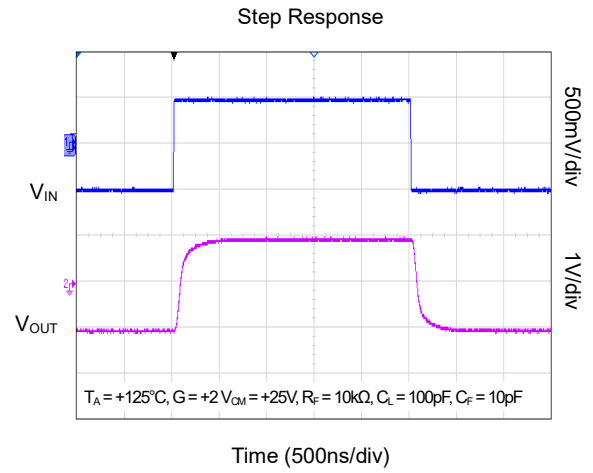
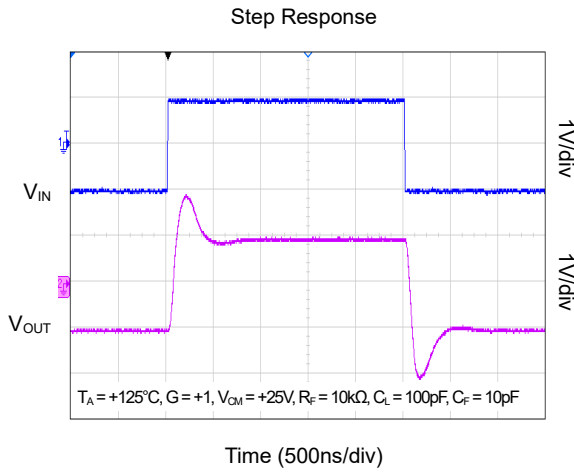

**TYPICAL PERFORMANCE CHARACTERISTICS (continued)**

At  $T_A = +25^\circ\text{C}$ ,  $V_S = \pm 35\text{V}$ , and  $R_L = 4.8\text{k}\Omega$  connected to GND, unless otherwise noted.

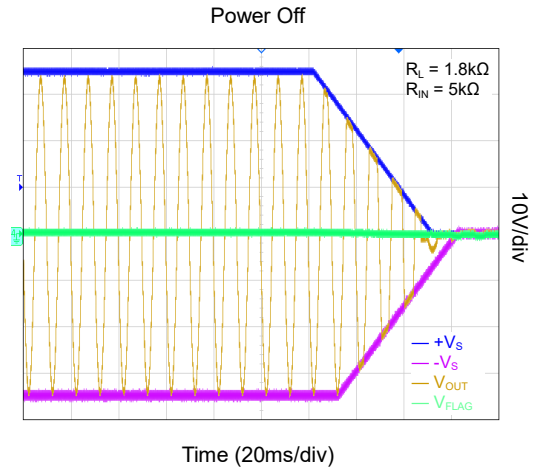
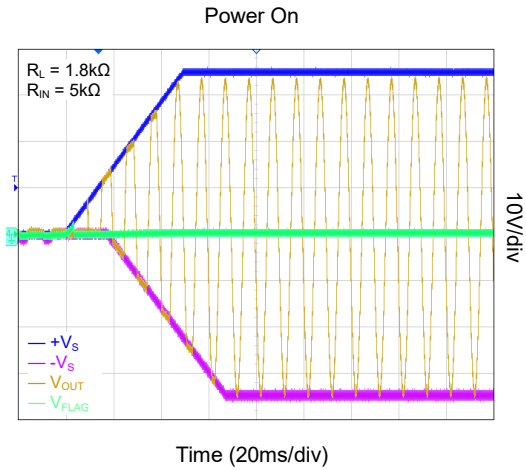
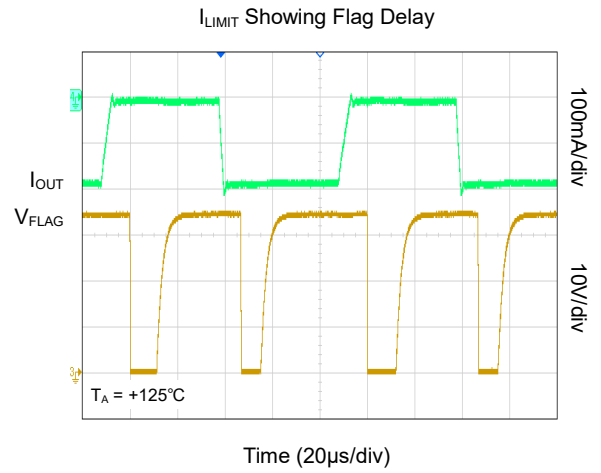
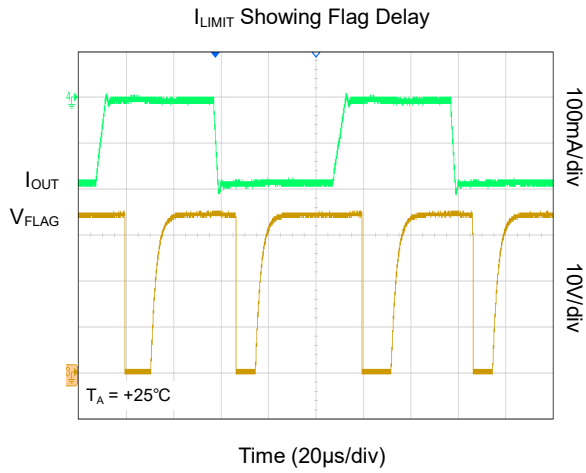

**FUNCTIONAL BLOCK DIAGRAM**

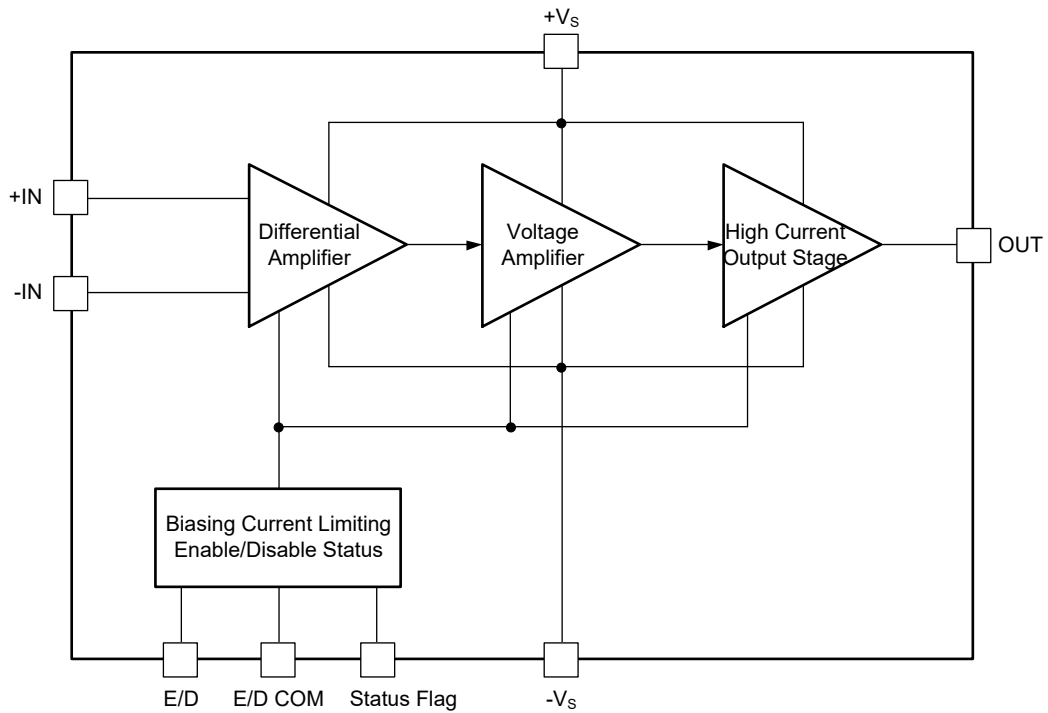

**Figure 2. Block Diagram**

**DETAILED DESCRIPTION**

The SGM8257A-1 features a maximum operating voltage of 70V and an output current capability of 50mA. The device offers stable unity-gain operation with a gain-bandwidth product of 2.8MHz. It provides wide input common mode voltage range and output voltage swing, and the output phase is not reversed within the specified input range. The accuracy performance of SGM8257A-1 is excellent. Moreover, the SGM8257A-1 is suitable for  $\pm 5V$  and  $\pm 35V$  applications, especially for those whose the power supply exceeds 36V.

The SGM8257A-1 integrates internal protection mechanisms for both input and output stages. For the input stage, the operational amplifier’s internal structure provides protection against multiple fault conditions. For the output stage, over-current and over-temperature events are detected and indicated by the Status Flag pin. Moreover, one of the advantages of SGM8257A-1 is that the output swings within 1V with the output current equal to  $\pm 50mA$ . The power consumption can be automatically high or low when the E/D pin is controlled by an external device. The E/D pin and Status Flag pin are related, specifically, the Status Flag will indicate a fault condition and be pulled high when the E/D pin is applied low.

**Input Protection**

The internal protective mechanism can protect the SGM8257A-1 from excessive differential input voltage or input terminals exceeding the power supply voltage, without any series resistors in front of the input terminals. The series JFET located at the input stage can limit the internal current to a non-damaging  $10\mu A$  for excessive differential or common mode input voltage. Moreover, a dielectric material is inserted between the device and the substrate. On top of this, the IC fabrication process for the SGM8257A-1 is also free from the traditional limitations of junction isolation.

**Input Range**

The SGM8257A-1 operates at a linear operational range when the input voltage swings within the range of  $(-V_S) + 2.5V$  and  $(+V_S) - 2.5V$ . Commonly, the unity-gain configuration is the most general application. Figure 6 indicates the test circuit for Figure 3 and Figure 4, which illustrate the output behavior when the input reaches  $+V_S$  or  $-V_S$ . Figure 5 shows the output response when the input voltage reaches  $(-V_S) + 1V$ . The phase reversal effect caused by excessive input voltage can be mitigated by adding a series resistor at the input terminal.

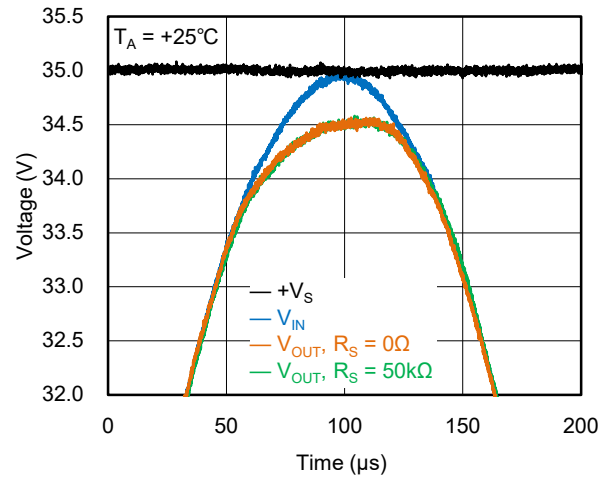

**Figure 3. Output Response when Input Voltage Reaches  $+V_S$**

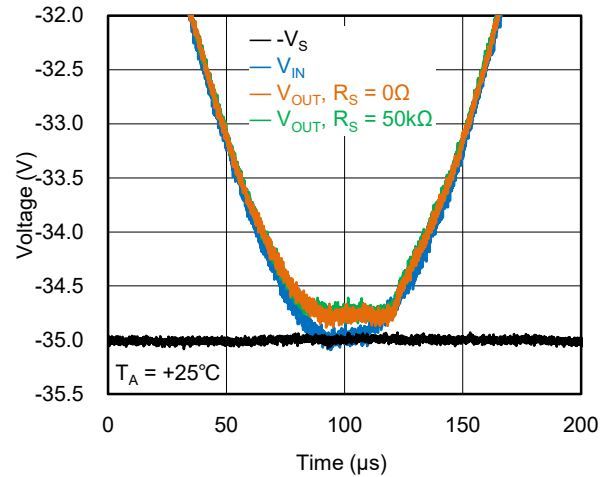

**Figure 4. Output Response when Input Voltage Reaches  $-V_S$**

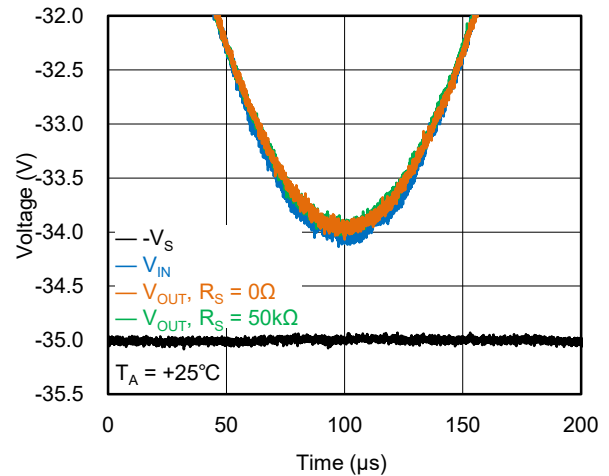

**Figure 5. Output Response when Input Voltage Reaches  $(-V_S) + 1V$**

DETAILED DESCRIPTION (continued)

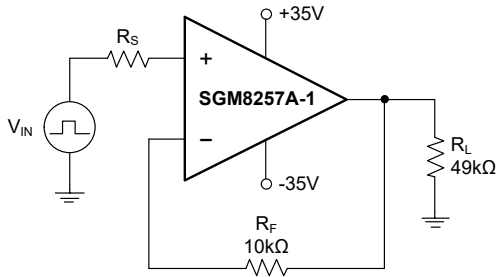

Figure 6. Input Range Test Circuit

Output Range

With a 49kΩ load, the SGM8257A-1 achieves an output swing within 1V of the supply rails. Output swing decreases as the output current increases. With a 1.88kΩ load, this device delivers an output swing within 2V of the (-V<sub>S</sub>) and 3V of the (+V<sub>S</sub>).

Settling Time

Settling time is measured using the circuit shown in Figure 7. The false-summing circuit at the top is utilized for both settling time and open-loop gain measurements. The two resistors R<sub>1</sub> and R<sub>2</sub> are used for isolating the summing junction from the probe and also provide a gain to the circuit, which will cause oscillation.

The combined output of the inverting and non-inverting circuits is applied by the circuit at the bottom, removing the large output response by the resistors R<sub>5</sub> and R<sub>6</sub>. The summing point at V<sub>2</sub> illustrates the output settling time.

Settling time measurement for different gain configurations are listed in Table 1.

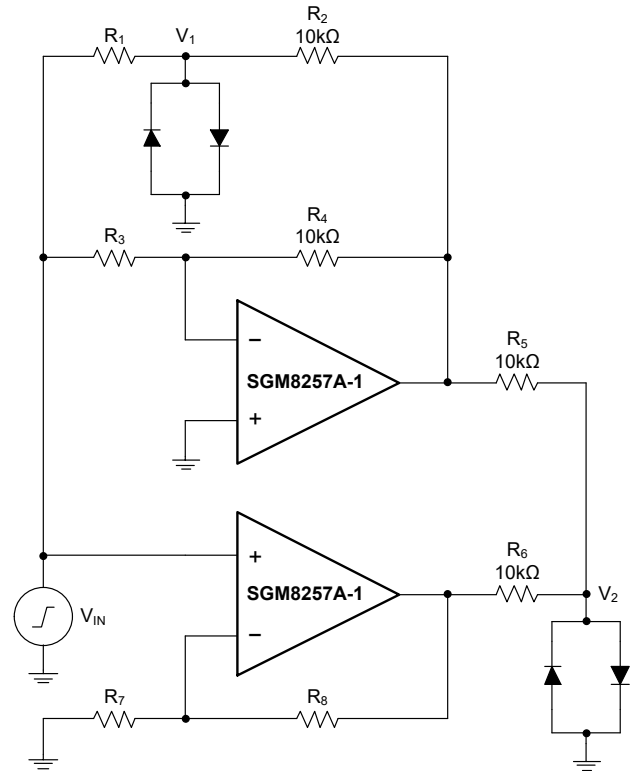

Figure 7. Settling Time Test Measurement Circuit

Table 1. Settling Time Measurement Configuration of Gain for Figure 7

Component	Gain		
	1	5	10
R <sub>1</sub>	10kΩ	2kΩ	1kΩ
R <sub>3</sub>	10kΩ	2kΩ	1kΩ
R <sub>7</sub>	∞	1kΩ	1kΩ
R <sub>8</sub>	10kΩ	4kΩ	9kΩ
V <sub>IN</sub>	20V <sub>P-P</sub>	12V <sub>P-P</sub>	6V <sub>P-P</sub>

**DETAILED DESCRIPTION (continued)**

**E/D and E/D COM**

If E/D COM is left floating, it will be driven to  $-V_S$  by a  $15\mu\text{A}$  internal current source. If E/D is floating, it will be  $2\text{V}$  higher than E/D COM, driven by a  $1\mu\text{A}$  internal current source. Although the SGM8257A-1 can still operate when both E/D and E/D COM are floating, a fast negative-coupled signal may cause the device to shut down by overpowering the  $1\mu\text{A}$  current source. This phenomenon, which can be illustrated as an oscillation, occurs frequently at extremely low temperatures. If the enable function is not intended for use, the conservative method is to place a  $30\text{pF}$  capacitor between the E/D pin and the low-impedance source. Moreover, an alternative way is to provide a sufficient current source from  $+V_S$  to keep E/D above the threshold of shutdown. The recommended connection for E/D is shown in Figure 8. The  $1\text{M}\Omega$  pull-up resistor  $R_P$ , connected between  $+V_S$  and E/D, can provide a  $35\mu\text{A}$  current source to the E/D pin.

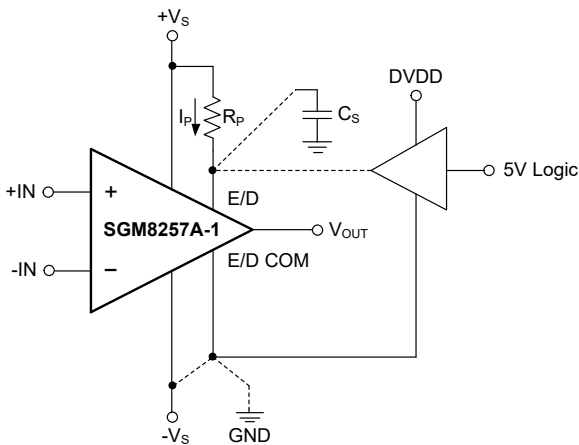

Figure 8. E/D and E/D COM

**Current Limit**

The internal limitation of the output transistors can limit the output current. Also, the output can continuously support the limited current when the operating temperature is below  $+125\text{ }^\circ\text{C}$ . However, if the SGM8257A-1 is powered by the lowest specified supply voltages with sufficient heat-sinking, the device can continuously deliver the limited current without triggering thermal shutdown. For the consideration of reliability, users should avoid cyclical operation of the thermal shutdown mechanism, even though research has shown that the device can operate in this mode for 1000 hours with minimal parametric shifts. In addition, good heat-sinking (achieved either via airflow or a physical plate) is required to maintain the device's operating temperature below the threshold of shutdown. For the operating life considerations, the junction temperature should always be below  $+150\text{ }^\circ\text{C}$ .

**Device Functional Modes**

The output disable function of SGM8257A-1 conserves power ( $I_{SD} = 200\mu\text{A}$ ). Also, this function protects the load without disturbing the input signal path. For shutdown loop control, this achievement is also useful.

**APPLICATION INFORMATION**

The SGM8257A-1 has the capability of high voltage and output current and can be applied under the power supply conditions of  $\pm 5V$  and  $\pm 35V$ . This design enables the SGM8257A-1 to operate in high supply voltage and high output swing situations that other traditional operational amplifiers cannot reach. Also, the output swing can be one volt or several volts within the supply rails, which is determined by the output current. Moreover, the SGM8257A-1 incorporates multiple protection mechanisms such as input over-voltage protection, output current-limit protection, thermal shutdown protection, and the E/D function.

**Lowering Offset Voltage and Drift**

Figure 9 illustrates that the SGM8257A-1 and SGM8253-1 (zero-drift series) can be combined to provide ultra-low input offset temperature drift while supporting high supply rails.

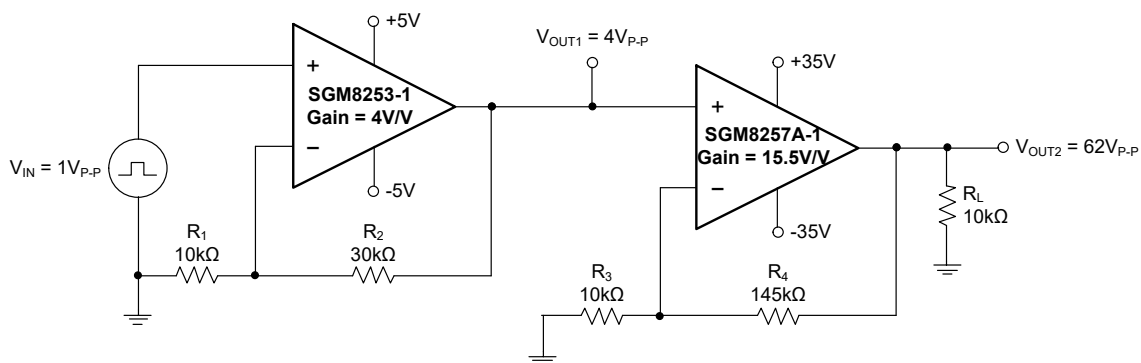
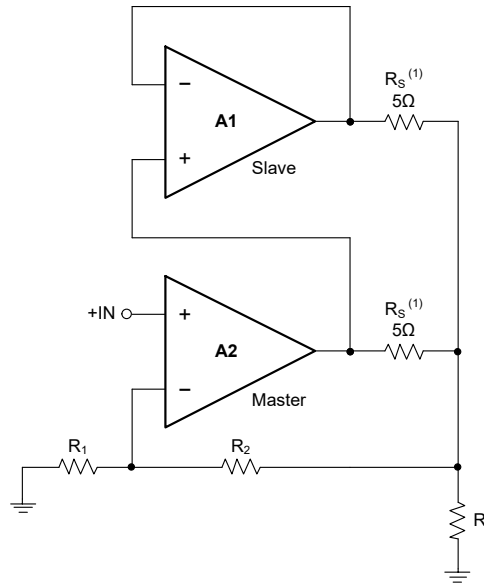

Figure 9. Two-Stage, High Voltage Operational Amplifier Circuit with Ultra-Low Input Offset Temperature Drift

APPLICATION INFORMATION (continued)

Increasing Output Current

Two or more SGM8257A-1 units can be paralleled to enhance the driving capability of the output current for better performance. The master operational amplifier (A2) can be configured in nearly all amplifier circuits. The slave operational amplifier (A1) should be configured as a buffer circuit without feedback resistor. In addition, external output transistors may be added if higher output current capability is required. In Figure 10, the circuit with SGM8257A-1 or external transistor can achieve an output current of 1A.



NOTE: 1. The  $R_s$  should always be placed to prevent any external current from flowing caused by the input offset voltage errors between the two operational amplifiers.

Figure 10. Parallel Amplifiers Increase Output Current Capability

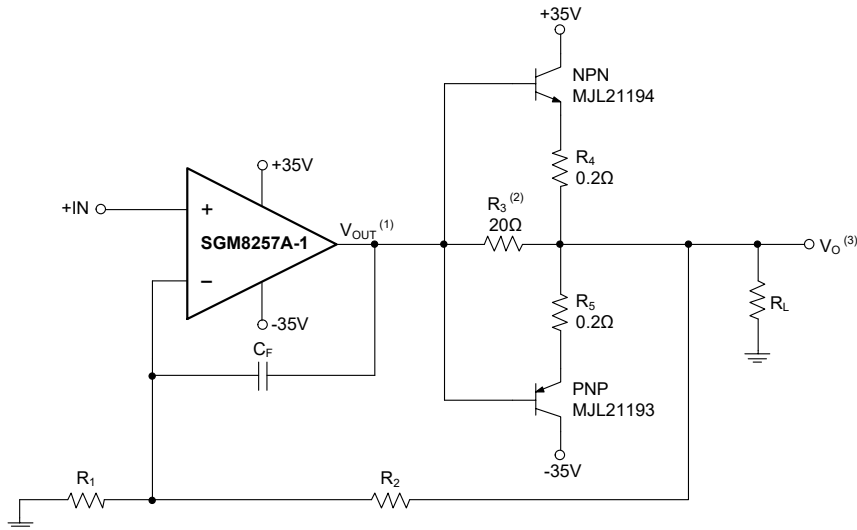

NOTES:

1. The output of the SGM8257A-1 can swing from +32V to -33V with suitable output loading.
2. Current limits consideration for SGM8257A-1 and also allows the operation of the circuit if the output voltage is within  $\pm 0.7V$  (avoiding crossover distortion).
3. For 1A loading, the  $V_{OUT}$  of SGM8257A-1 can swing from +29.1V to -30.1V.

Figure 11. 1A Loading Application Achieved by SGM8257A-1 and External Transistors

**APPLICATION INFORMATION (continued)**

**Basic Non-Inverting Amplifier**

The non-inverting circuit is shown in Figure 12. The SGM8257A-1 can be operated with the power supplies of  $\pm 5V$  to  $\pm 35V$  with excellent linearity, which is acceptable for the applications with power supplies exceeding 36V.

The 100nF bypass capacitors should be connected to the terminals of the two supply pins as close as possible. Also, the voltage rating of the capacitors should be much larger than the corresponding operating supply voltage.

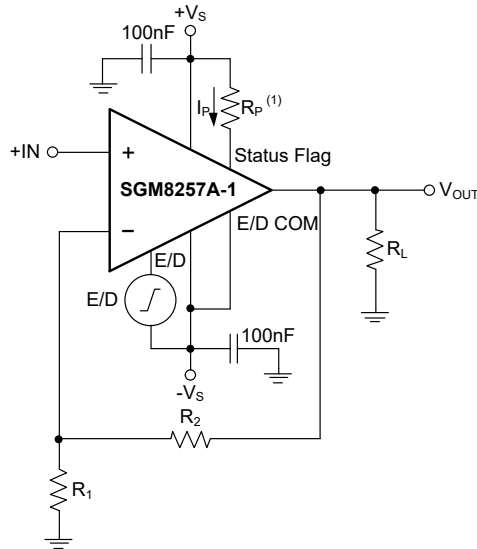

NOTE: 1. Pull-up resistor with at least 15 $\mu A$  (choose  $R_P = 1M\Omega$  with  $+V_S = 35V$  for  $I_P = 35\mu A$ ).

**Figure 12. Configuring the SGM8257A-1 as a Non-inverting Circuit**

**Programmable Voltage Source**

Figure 13 illustrates the SGM8257A-1 in a programmable voltage source.

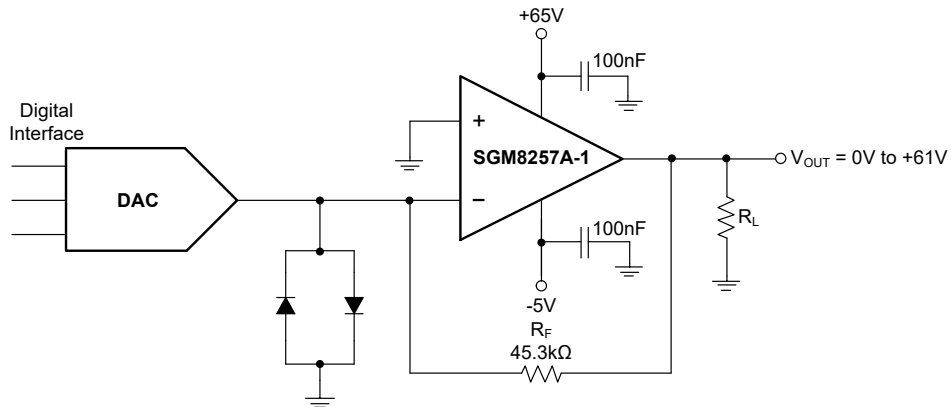
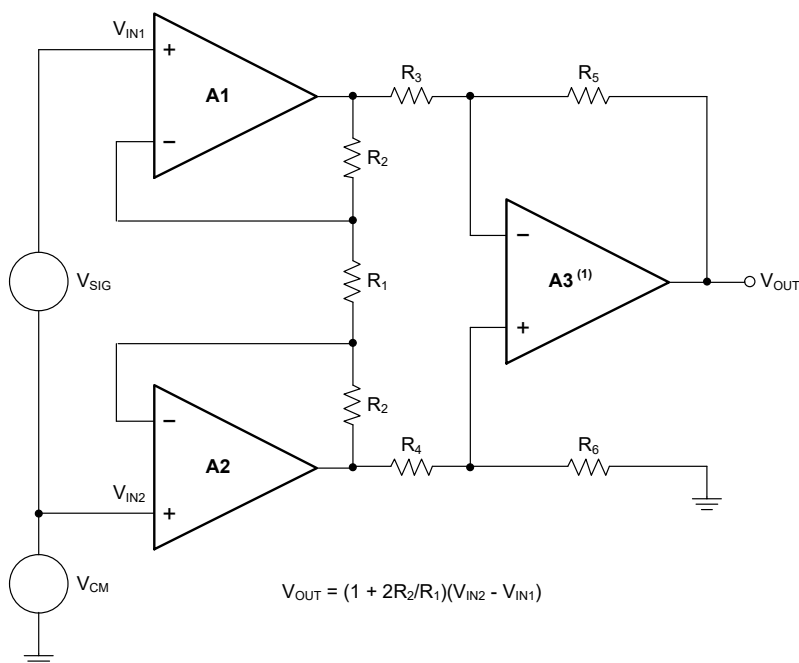

**Figure 13. Programmable Voltage Source**

APPLICATION INFORMATION (continued)

High Voltage Instrumentation Amplifier

The high voltage instrumentation circuit application is shown in Figure 14. The voltage of  $V_{CM} + V_{SIG}$  should be always within the input range between  $(-V_S) + 2.5V$  and  $(+V_S) - 2.5V$ . The supply rails should also be limited to the range of  $\pm 35V$  or  $70V$ .



NOTE: 1. The linear input range is determined by the two operational amplifiers, which are A1 and A2.

Figure 14. High Voltage Instrumentation Amplifier

APPLICATION INFORMATION (continued)

The high-side current measurement is illustrated in Figure 15. The  $V_{SUPPLY}$  should be always within the linear input range between  $(-V_S) + 2.5V$  and  $(+V_S) - 2.5V$ . The supply rails should also be limited to the range of  $\pm 35V$  or  $70V$ .

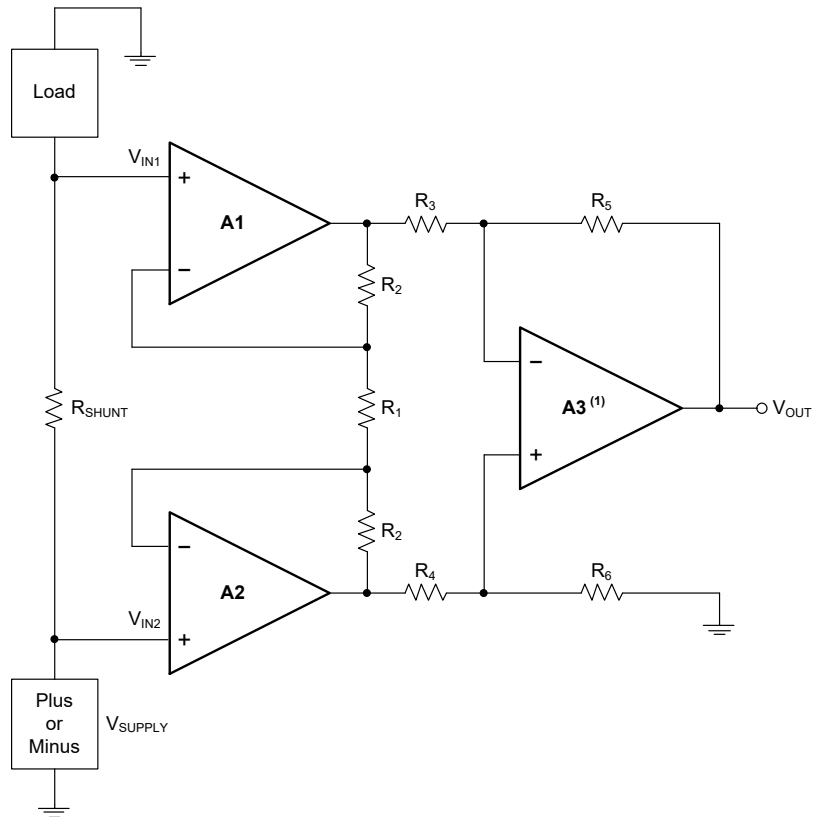

NOTES:

1. A<sub>1</sub> and A<sub>2</sub> should be applied as buffer circuits to increase the input voltage range of the current-sense circuit.
2. The maximum output swing of A<sub>1</sub> and A<sub>2</sub> limits the linear range of the circuit.

Figure 15. Current-Sense Monitor with Instrumentation Circuitry

## APPLICATION INFORMATION (continued)

## Power Supply Recommendations

The supply rails should also be limited to the range of  $\pm 35\text{V}$  or  $70\text{V}$  for the linearity of SGM8257A-1. Most of the parameters remain unchanged for the full power supply ranges. The Electrical Characteristics section illustrates which parameters change with different power supply rails.

Most of the applications do not need equalized absolute values of the output swing so that the two supply rails do not need to be absolutely equal. The difference voltage of the maximum supply rails can be acceptable from  $10\text{V}$  to  $70\text{V}$ . For instance, the two supply rails can be  $60\text{V}$  and  $-10\text{V}$  respectively (it is essential for operation to make sure that the voltage difference between the two supply rails is equal to or less than  $70\text{V}$ ).

## Layout

## Thermally-Enhanced Exposed Pad Package

A low-resistance ( $\theta_{JC}$ ) thermal path is achieved by the exposed pad package of SGM8257A-1, which has a direct thermal path from the internal die to the exposed pad. In addition, for better performance, providing a good thermal path is essential.

The exposed pad construction is shown in Figure 16. On the bottom-side of the SOIC-8 (Exposed Pad) package, the lead frame is completely exposed as a thermal pad. The heat-sinking area of the PCB is tied together with the exposed pad of SGM8257A-1. Moreover, the vias should also be placed on the PCB to conduct the heat to the bottom of the PCB. This kind of heat-sinking structure provides a convenient way for conducting heat and is also simple for the operator to mount.

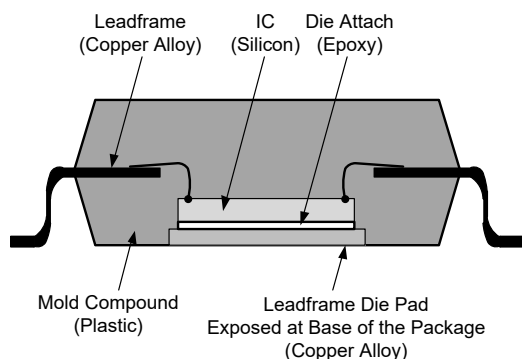

Figure 16. Cross-Section View of an Exposed Pad Package

## Exposed Pad Layout Guidelines

The thermal pad of the package should always be mounted on the surface of the exposed copper of the PCB. This copper area has the ability to provide a thermal path and conduct the heat away from the package to any other heat-dissipating devices. Although the power consumption of the application is ultra-low, the exposed pad is also required to be mounted to the copper area of the PCB. The following steps illustrate the details of connecting the package to the PCB:

- ◆ Both thermal pads and leads should be etched, which means that the PCB with a top-side etch is required.
- ◆ The exposed pad should always be connected to the  $-V_S$  of SGM8257A-1.
- ◆ In the thermal pad of the PCB, placing the recommended amount of holes is significant. The size of the area on the PCB should always comply with the mechanical drawing which is shown in the appendix. The diameter of these holes should be 13mils (.013in, or 0.3302mm) so that solder wicking through the holes will not cause a problem for reflow. The recommended amount of holes for the exposed pad of the package is five.
- ◆ Providing vias on the PCB is recommended for better heat dissipation, but it is not required. The exposed copper area of the PCB should always be equal to the exposed pad if there are no vias, and connecting this area to  $-V_S$  is required.
- ◆ Outside the area of thermal pad, the additional vias can be placed along the thermal plane, which is essential for the IC itself to conduct and dissipate the internal heat. In addition, the diameter of these holes should be larger than that of the holes in the thermal pad area (13mil). The reason is that they are not located at the area that needs to be soldered, which means that wicking will never be affected.
- ◆ All of the vias connected to the thermal pad area should be connected to  $-V_S$  for better thermal dissipation.

## APPLICATION INFORMATION (continued)

♦ The area of the thermal pad for the SGM8257A-1 should always be left exposed for the consideration of thermal dissipation. The holes which are located on the bottom side of the PCB should be covered all the time for preventing the solder from being pulled away during the process of reflow.

♦ The traditional technology such as typical web or the connection of spoke via is not recommended when connecting the holes to the plane. The thermal resistance is extremely high for the web connection so that it can slow the heat transfer for soldering. However, for the SGM8257A-1 applications, low thermal resistance is desired and required for the efficiency of the heat transfer. Therefore, for reducing the thermal resistance, the operator should make the vias which are located on the exposed pad connect completely to the internal plane of the PCB.

♦ The solder should be applied to the exposed power pad area and all the terminals of the SGM8257A-1.

♦ After finishing the preparation of the above steps, the SGM8257A-1 can be connected to the specific locations of the PCB through the reflow process.

## Power Dissipation

The power dissipation is strongly related to the input signal levels, voltage of the power supply rails and the loading. If a DC signal is applied to the input of the SGM8257A-1, the mathematical relationship between the power dissipation and the load current is:  $P_D = I_L \times (V_S - V_{OUT})$ . According to the output voltage level, the voltage of the power supply rails should be reduced to minimize the power dissipation of the amplifier.

The maximum power dissipation occurs when the output voltage is equal to one-half of the voltage of the power supply rails for the resistive loads. However, the power dissipation of an AC signal is much lower, since the root-mean-square (RMS) value of power dissipation ( $P_D$ ) should be taken into account. Figure 17 illustrates a constant current source circuit in which the maximum  $P_D$  occurs at the minimum output voltage.

For normal operations, the SGM8257A-1 can supply 25mA or more output current. If the supply power is equal to  $\pm 15V$ , this amount of current can be supplied

without any problem. However, the power dissipation will increase dramatically with the rise of the power supply rails. Moreover, unbalanced power supply rails will apply a larger voltage across the output transistor so that power dissipation is increased. A heat spreader is required for high power dissipation applications.

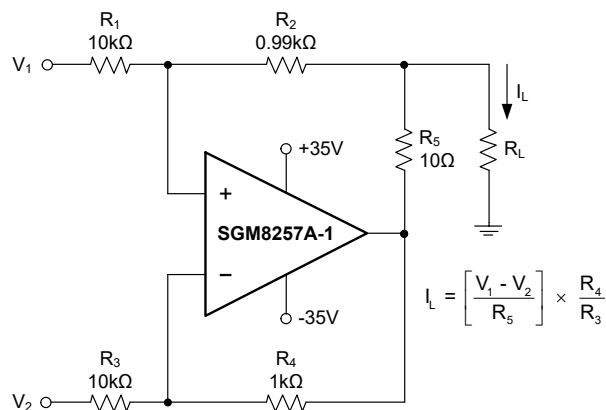

NOTE:  $R_1 = R_3$  and  $R_4 = R_2 + R_5$ .

Figure 17. Precision Voltage-to-Current Converter with Differential Inputs

## Heat-Sinking

The junction temperature (limited to  $+150^\circ\text{C}$ ) rises accordingly with the increase of power dissipation. Most of the applications need a heatsink to reduce the effect of power dissipation for better operation stability, so that the junction temperature is not exceeded. Equation 1 illustrates the mathematical expression of the junction temperature:

$$T_J = T_A + P_D \times \theta_{JA} \quad (1)$$

$\theta_{JA}$ , the thermal resistance of the package, is strongly related to the environment. The thermal resistance is increased dramatically for socketing and poor air circulation. In addition, most of the applications have one or more channels that require many amplifiers, and these amplifiers will be placed close together, so that the surrounding temperature will increase accordingly. One of the methods to improve the thermal performance is using wide PCB trace to connect the SGM8257A-1.

**REVISION HISTORY**

NOTE: Page numbers for previous revisions may differ from page numbers in the current version.

<b>Changes from Original to REV.A (APRIL 2026)</b>	<b>Page</b>
Changed from product preview to production data.....	All

---

# PACKAGE INFORMATION

## PACKAGE OUTLINE DIMENSIONS

### SOIC-8 (Exposed Pad)

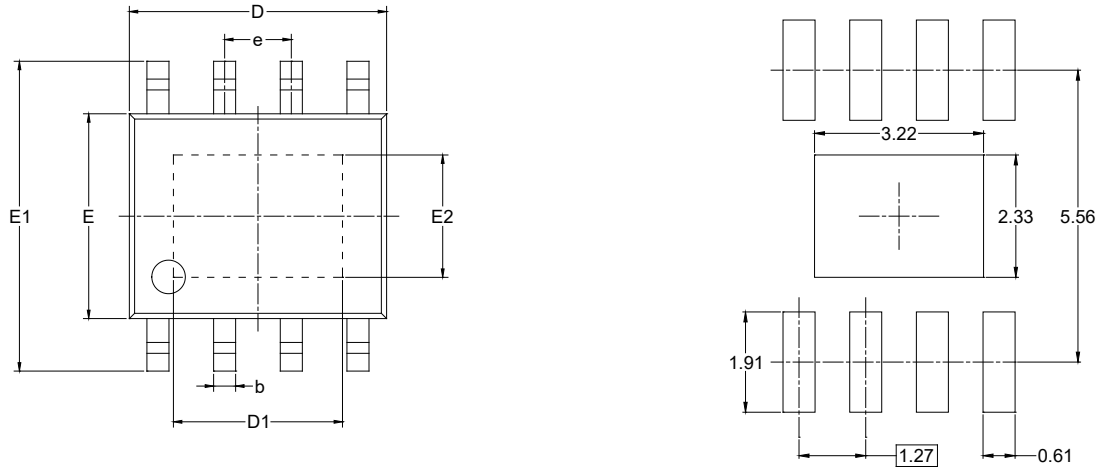

RECOMMENDED LAND PATTERN (Unit: mm)

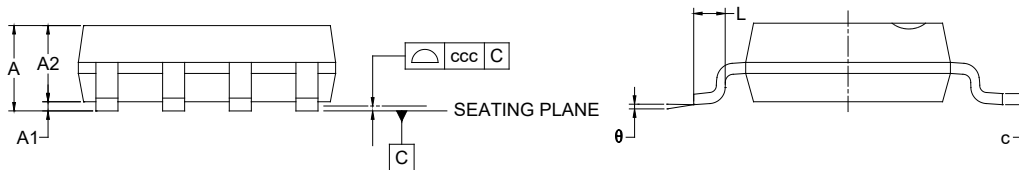

Symbol	Dimensions In Millimeters		
	MIN	NOM	MAX
A			1.700
A1	0.000	-	0.150
A2	1.250	-	1.650
b	0.330	-	0.510
c	0.170	-	0.250
D	4.700	-	5.100
D1	3.020	-	3.420
E	3.800	-	4.000
E1	5.800	-	6.200
E2	2.130	-	2.530
e	1.27 BSC		
L	0.400	-	1.270
$\theta$	0°	-	8°
ccc	0.100		

NOTES:

1. This drawing is subject to change without notice.
2. The dimensions do not include mold flashes, protrusions or gate burrs.
3. Reference JEDEC MS-012.

# PACKAGE INFORMATION

## TAPE AND REEL INFORMATION

### REEL DIMENSIONS

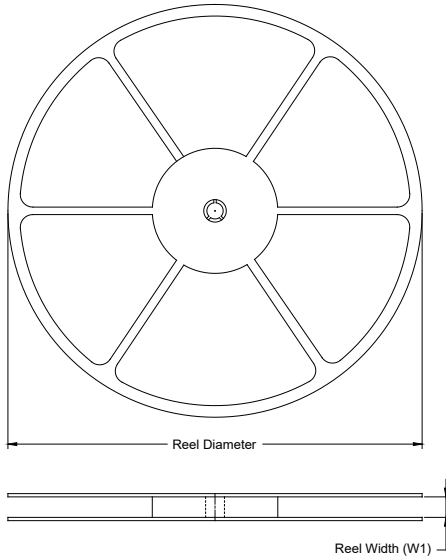

### TAPE DIMENSIONS

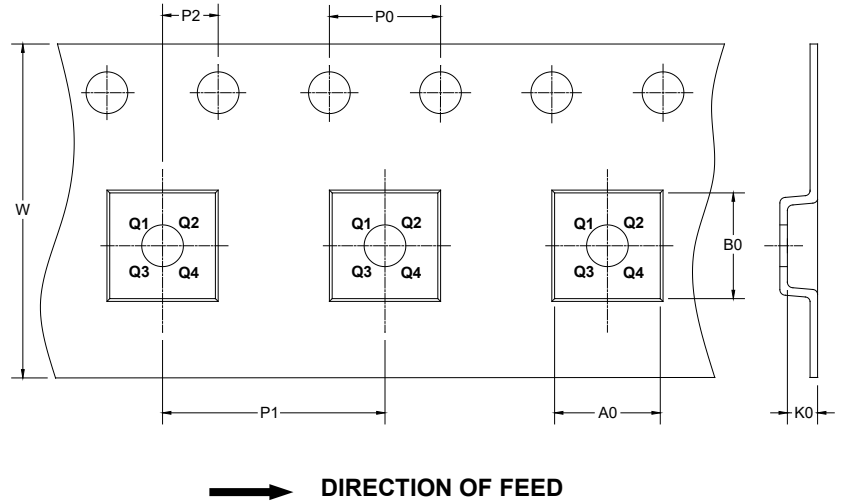

NOTE: The picture is only for reference. Please make the object as the standard.

### KEY PARAMETER LIST OF TAPE AND REEL

Package Type	Reel Diameter	Reel Width W1 (mm)	A0 (mm)	B0 (mm)	K0 (mm)	P0 (mm)	P1 (mm)	P2 (mm)	W (mm)	Pin1 Quadrant
SOIC-8 (Exposed Pad)	13"	12.4	6.40	5.40	2.10	4.0	8.0	2.0	12.0	Q1

DD0001

# PACKAGE INFORMATION

## CARTON BOX DIMENSIONS

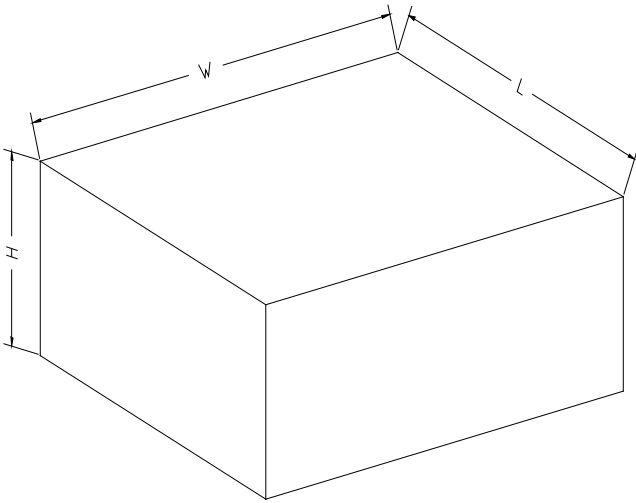

NOTE: The picture is only for reference. Please make the object as the standard.

## KEY PARAMETER LIST OF CARTON BOX

Reel Type	Length (mm)	Width (mm)	Height (mm)	Pizza/Carton
13"	386	280	370	5

DD0002