



SGM2254xQ Automotive 40V, 300mA, Low Quiescent Current and Low Dropout Voltage Linear Regulator

GENERAL DESCRIPTION

The SGM2254xQ is a high voltage, low quiescent current and low dropout voltage linear regulator. It is capable of supplying 300mA output current with typical dropout voltage of 770mV. The operating input voltage range is from 2.5V to 40V. The fixed output voltage range is from 1.8V to 12V.

Other features include current limit and thermal shutdown protection. The SGM2254xQ is suitable for various automotive applications.

This device is AEC-Q100 qualified (Automotive Electronics Council (AEC) standard Q100 Grade 1) and it is suitable for automotive applications.

The SGM2254xQ is available in Green TDFN-3×3-8JL and SOT-223-3 packages. It operates over an operating temperature range of -40°C to +125°C.

APPLICATIONS

Industrial Equipment
Automotive Applications
Battery-Powered Equipment
Medical Equipment

FEATURES

- AEC-Q100 Qualified for Automotive Applications
Device Temperature Grade 1
 $T_A = -40^{\circ}\text{C}$ to $+125^{\circ}\text{C}$
- Operating Input Voltage Range: 2.5V to 40V
- Enable Pin Accept Voltages Higher than the Supply Voltage and up to 40V
- Fixed Output from 1.8V to 12V
- 300mA Output Current
- Output Voltage Accuracy: $\pm 1\%$ at $+25^{\circ}\text{C}$
- Low Quiescent Current: 3.2 μA (TYP)
- Low Dropout Voltage:
770mV (TYP) at 300mA, $V_{\text{OUT}} = 5.0\text{V}$
- Current Limiting and Thermal Protection
- With Output Automatic Discharge
- Stable with Small Case Size Ceramic Capacitors
- -40°C to +125°C Operating Temperature Range
- Available in Green TDFN-3×3-8JL and SOT-223-3 Packages

TYPICAL APPLICATION

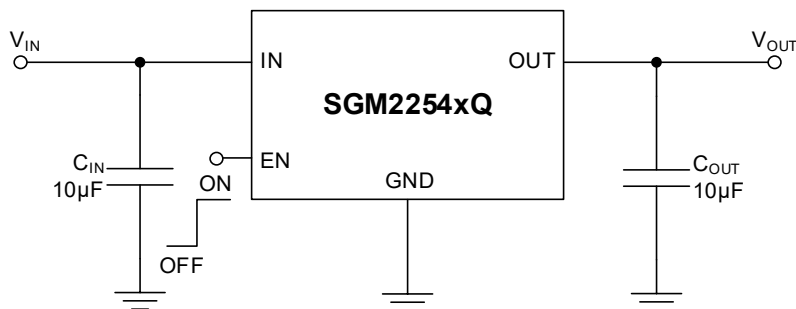

Figure 1. Typical Application Circuit

Automotive 40V, 300mA, Low Quiescent SGM2254xQ Current and Low Dropout Voltage Linear Regulator

PACKAGE/ORDERING INFORMATION

MODEL	PACKAGE DESCRIPTION	SPECIFIED TEMPERATURE RANGE	ORDERING NUMBER	PACKAGE MARKING	PACKING OPTION
SGM2254-1.8Q	TDFN-3×3-8JL	-40°C to +125°C (T _A)	SGM2254-1.8QTHI8G/TR	2NJTHI XXXXX XX#XX	Tape and Reel, 4000
SGM2254-2.5Q	TDFN-3×3-8JL	-40°C to +125°C (T _A)	SGM2254-2.5QTHI8G/TR	2OYTHI XXXXX XX#XX	Tape and Reel, 4000
SGM2254-3.3Q	TDFN-3×3-8JL	-40°C to +125°C (T _A)	SGM2254-3.3QTHI8G/TR	280THI XXXXX XX#XX	Tape and Reel, 4000
SGM2254-5.0Q	TDFN-3×3-8JL	-40°C to +125°C (T _A)	SGM2254-5.0QTHI8G/TR	281THI XXXXX XX#XX	Tape and Reel, 4000
SGM2254-12Q	TDFN-3×3-8JL	-40°C to +125°C (T _A)	SGM2254-12QTTHI8G/TR	2OZTHI XXXXX XX#XX	Tape and Reel, 4000
SGM2254-1.8Q	SOT-223-3	-40°C to +125°C (T _A)	SGM2254-1.8QKC3G/TR	282 XXXYY	Tape and Reel, 2500
SGM2254-2.5Q	SOT-223-3	-40°C to +125°C (T _A)	SGM2254-2.5QKC3G/TR	2OX XXXYY	Tape and Reel, 2500
SGM2254-3.3Q	SOT-223-3	-40°C to +125°C (T _A)	SGM2254-3.3QKC3G/TR	2AJ XXXYY	Tape and Reel, 2500
SGM2254-5.0Q	SOT-223-3	-40°C to +125°C (T _A)	SGM2254-5.0QKC3G/TR	2MH XXXYY	Tape and Reel, 2500
SGM2254-12Q	SOT-223-3	-40°C to +125°C (T _A)	SGM2254-12QKC3G/TR	283 XXXYY	Tape and Reel, 2500

MARKING INFORMATION

NOTE: XXXXX = Date Code, Trace Code and Vendor Code. XX#XX = Coordinate Information and Wafer ID Number. XXXYY = Date Code, Trace Code and Lot Number.

TDFN-3×3-8JL

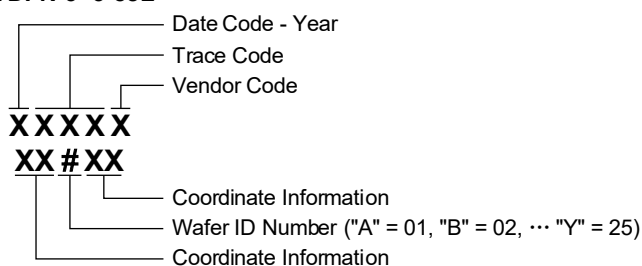

SOT-223-3

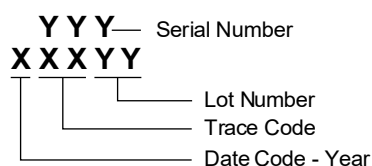

SGM2254xQ Automotive 40V, 300mA, Low Quiescent Current and Low Dropout Voltage Linear Regulator

ABSOLUTE MAXIMUM RATINGS

IN, EN to GND	-0.3V to 45V
OUT to GND	-0.3V to 45V
Package Thermal Resistance	
TDFN-3×3-8JL, θ_{JA}	44.4°C/W
TDFN-3×3-8JL, θ_{JB}	18.8°C/W
TDFN-3×3-8JL, $\theta_{JC(TOP)}$	47.3°C/W
TDFN-3×3-8JL, $\theta_{JC(BOT)}$	7.7°C/W
SOT-223-3, θ_{JA}	58.6°C/W
SOT-223-3, θ_{JB}	13.4°C/W
SOT-223-3, θ_{JC}	44.6°C/W
Junction Temperature	+150°C
Storage Temperature Range	-65°C to +150°C
Lead Temperature (Soldering, 10s)	+260°C
ESD Susceptibility ^{(1) (2)}	
HBM	±6000V
CDM	±1000V

NOTES:

1. For human body model (HBM), all pins comply with AEC-Q100-002 specification.
2. For charged device model (CDM), all pins comply with AEC-Q100-011 specification.

RECOMMENDED OPERATING CONDITIONS

Supply Voltage Range, V_{IN}	2.5V to 40V
Enable Input Voltage Range	0V to 40V
Input Effective Capacitance, C_{IN}	0.5 μ F (MIN)
Output Effective Capacitance, C_{OUT}	1 μ F to 100 μ F
Operating Ambient Temperature Range	-40°C to +125°C
Operating Junction Temperature Range	-40°C to +150°C

OVERSTRESS CAUTION

Stresses beyond those listed in Absolute Maximum Ratings may cause permanent damage to the device. Exposure to absolute maximum rating conditions for extended periods may affect reliability. Functional operation of the device at any conditions beyond those indicated in the Recommended Operating Conditions section is not implied.

ESD SENSITIVITY CAUTION

This integrated circuit can be damaged if ESD protections are not considered carefully. SGMICRO recommends that all integrated circuits be handled with appropriate precautions. Failure to observe proper handling and installation procedures can cause damage. ESD damage can range from subtle performance degradation to complete device failure. Precision integrated circuits may be more susceptible to damage because even small parametric changes could cause the device not to meet the published specifications.

DISCLAIMER

SG Micro Corp reserves the right to make any change in circuit design, or specifications without prior notice.

Automotive 40V, 300mA, Low Quiescent SGM2254xQ Current and Low Dropout Voltage Linear Regulator

PIN CONFIGURATIONS

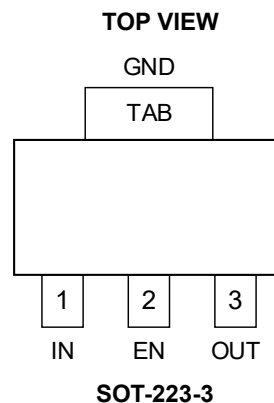
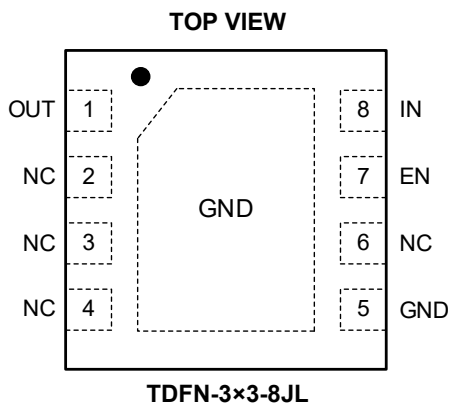

PIN DESCRIPTION

PIN		NAME	FUNCTION
TDFN-3x3-8JL	SOT-223-3		
1	3	OUT	Regulator Output Pin. It is recommended to use a ceramic capacitor with effective capacitance in the range of 1 μ F to 100 μ F to ensure stability. This ceramic capacitor should be placed as close as possible to OUT pin.
2, 3, 4, 6	—	NC	No Connection.
5	—	GND	Ground.
7	2	EN	Enable Pin. Drive EN high to turn on the regulator. Drive EN low to turn off the regulator.
8	1	IN	Input Supply Voltage Pin. It is recommended to use a 1 μ F or larger ceramic capacitor from IN pin to ground to get good power supply decoupling. This ceramic capacitor should be placed as close as possible to IN pin.
Exposed Pad	TAB	GND	Connect it to GND Internally. Connect it to a large ground plane to maximize thermal performance. This pad is not an electrical connection point.

SGM2254xQ Automotive 40V, 300mA, Low Quiescent Current and Low Dropout Voltage Linear Regulator

FUNCTIONAL BLOCK DIAGRAM

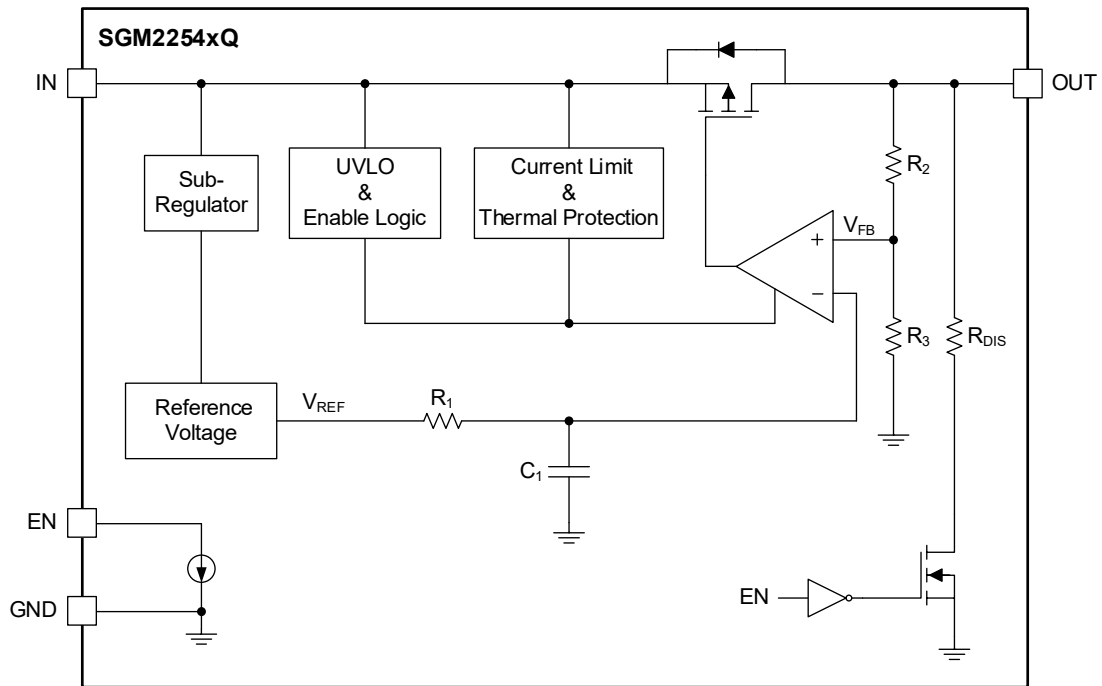

Figure 2. Block Diagram

Automotive 40V, 300mA, Low Quiescent SGM2254xQ Current and Low Dropout Voltage Linear Regulator

ELECTRICAL CHARACTERISTICS

($V_{IN} = V_{OUT(NOM)} + 2V$, $C_{IN} = 10\mu F$, $C_{OUT} = 10\mu F$, $T_J = -40^\circ C$ to $+125^\circ C$ ⁽¹⁾, typical values are at $T_J = +25^\circ C$, unless otherwise noted.)

PARAMETER	SYMBOL	CONDITIONS	MIN	TYP	MAX	UNITS	
Input Voltage Range	V_{IN}		2.5		40	V	
Output Voltage Range	V_{OUT}		1.8		12	V	
Output Voltage Accuracy	V_{OUT}	$V_{IN} = (V_{OUT(NOM)} + 2V)$ to 40V, $I_{OUT} = 1mA$	$T_J = +25^\circ C$	-1	+1	%	
			$T_J = -40^\circ C$ to $+125^\circ C$	-2	+1.5		
Under-Voltage Lockout	V_{UVLO}	V_{IN} rising		2.1	2.48	V	
Line Regulation	$\frac{\Delta V_{OUT}}{\Delta V_{IN} \times V_{OUT}}$	$V_{IN} = (V_{OUT(NOM)} + 2V)$ to 40V, $I_{OUT} = 0.1mA$		0.0002	0.02	%/V	
Load Regulation	$\frac{\Delta V_{OUT}}{\Delta I_{OUT} \times V_{OUT}}$	$I_{OUT} = 0.1mA$ to 300mA		0.0002	0.005	%/mA	
Dropout Voltage	V_{DROP}	$V_{OUT} = 95\% \times V_{OUT(NOM)}$, $I_{OUT} = 300mA$	$V_{OUT(NOM)} = 1.8V$		950	1900	mV
			$V_{OUT(NOM)} = 3.3V$		830	1800	
			$V_{OUT(NOM)} = 5.0V$		770	1700	
Output Current Limit	I_{LIMIT}	$V_{IN} = V_{OUT} + 4V$, $V_{OUT} = 90\% \times V_{OUT(NOM)}$	300	755		mA	
Short-Circuit Current Limit	I_{SHORT}	$V_{IN} = V_{OUT(NOM)} + 3V$, $V_{OUT} = 0V$		265		mA	
Ground Pin Current	I_{GND}	$I_{OUT} = 0mA$		3.2	8	μA	
		$I_{OUT} = 300mA$		125	260		
Shutdown Supply Current	I_{SHDN}	$V_{EN} = 0V$, $V_{IN} = 2.5$ to 40V		0.3	1.5	μA	
EN Pin High-Level Input Voltage	V_{IH}	$V_{IN} = 2.5$ to 40V	1.8		40	V	
EN Pin Low-Level Input Voltage	V_{IL}	$V_{IN} = 2.5$ to 40V	0		1	V	
EN Pin Input Current	I_{ENH}	$V_{IN} = 40V$, $V_{EN} = 40V$		50	1000	nA	
	I_{ENL}	$V_{IN} = 40V$, $V_{EN} = 0V$		5	500		
Output Discharge Resistance	R_{DIS}	$V_{EN} = 0V$		215		Ω	
Turn-On Time	t_{ON}	From assertion of V_{EN} to $V_{OUT} = 90\% \times V_{OUT(NOM)}$	$V_{OUT(NOM)} = 1.8V$		0.8	1.5	ms
			$V_{OUT(NOM)} = 3.3V$		1.0	1.6	
			$V_{OUT(NOM)} = 5.0V$		1.3	2.2	
			$V_{OUT(NOM)} = 12V$		2.8	4.4	
Power Supply Ripple Rejection	PSRR	$V_{IN} = 5.3V$, $V_{OUT(NOM)} = 3.3V$, $I_{OUT} = 10mA$, $C_{OUT} = 4.7\mu F$	$f = 100Hz$		61	dB	
			$f = 1kHz$		45		
			$f = 100kHz$		45		
Output Voltage Noise	e_n	$V_{OUT(NOM)} = 3.3V$, $I_{OUT} = 10mA$, $C_{OUT} = 4.7\mu F$, $f = 10Hz$ to 100kHz		105		μV_{RMS}	
Thermal Shutdown Temperature	T_{SHDN}	T_J rising		160		$^\circ C$	
Thermal Shutdown Hysteresis	ΔT_{SHDN}	Hysteresis		20		$^\circ C$	

NOTE:

1. Tested under pulse load conditions, so $T_J \approx T_A$.

Automotive 40V, 300mA, Low Quiescent Current and Low Dropout Voltage Linear Regulator

SGM2254xQ

TYPICAL PERFORMANCE CHARACTERISTICS

$T_J = +25^\circ\text{C}$, $V_{EN} = V_{IN}$, $C_{IN} = 10\mu\text{F}$, $C_{OUT} = 10\mu\text{F}$, unless otherwise noted.

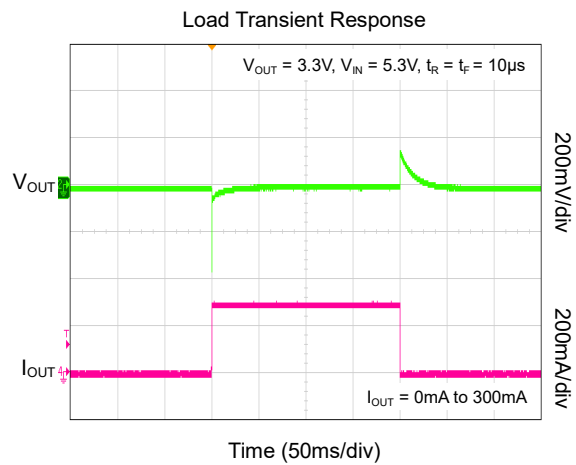
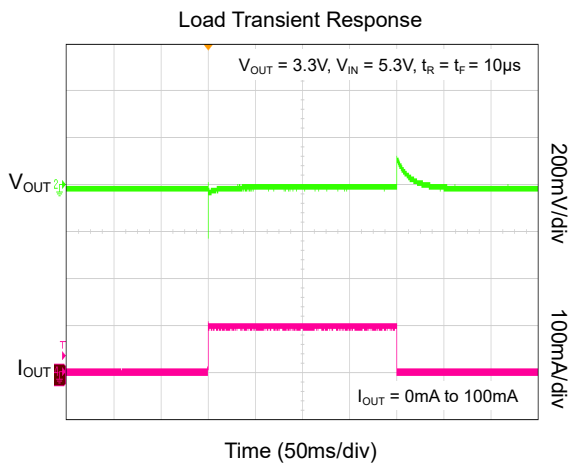
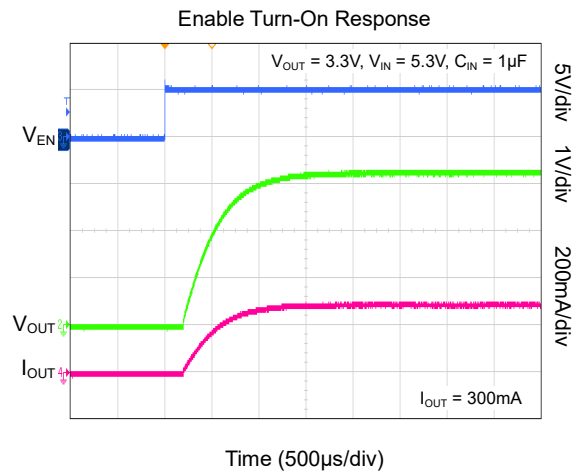
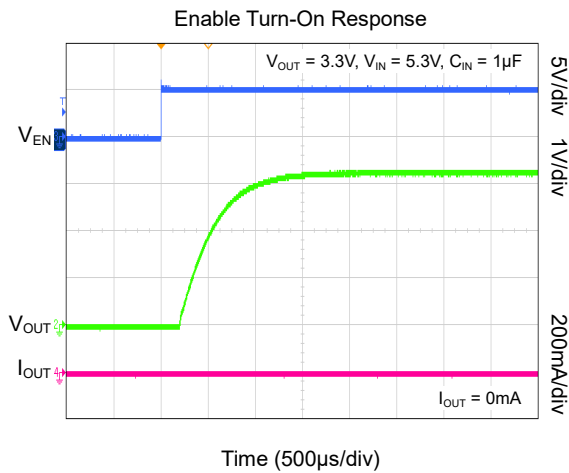
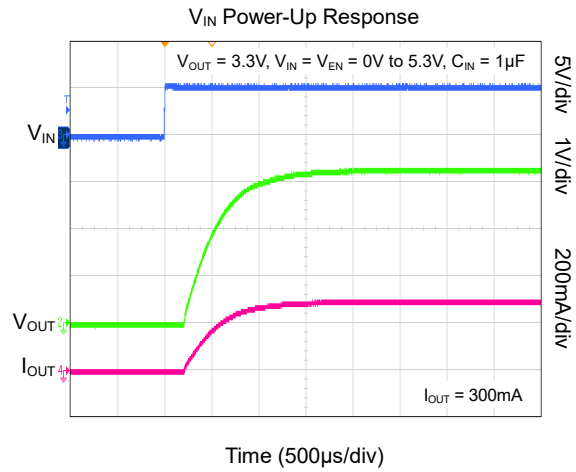
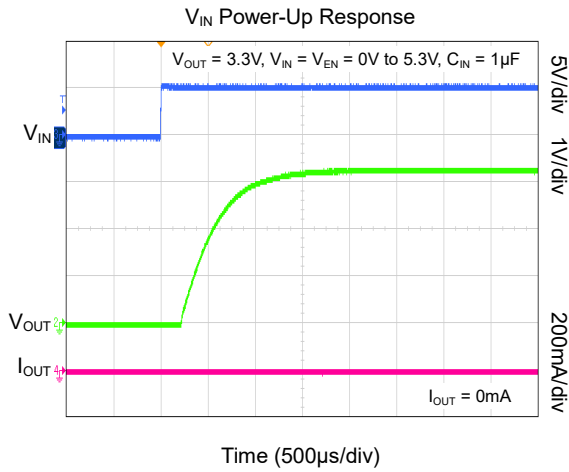

Automotive 40V, 300mA, Low Quiescent SGM2254xQ Current and Low Dropout Voltage Linear Regulator

TYPICAL PERFORMANCE CHARACTERISTICS (continued)

$T_J = +25^\circ\text{C}$, $V_{EN} = V_{IN}$, $C_{IN} = 10\mu\text{F}$, $C_{OUT} = 10\mu\text{F}$, unless otherwise noted.

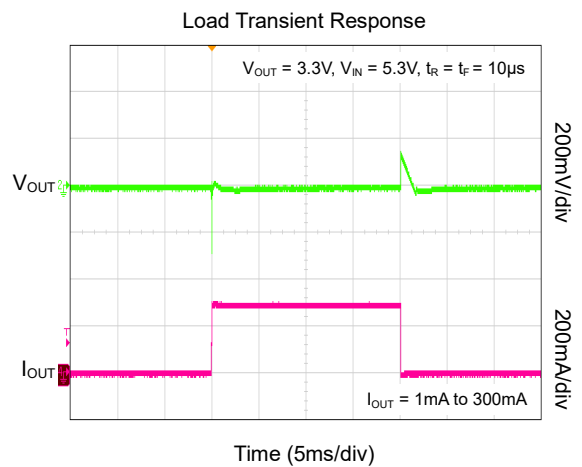
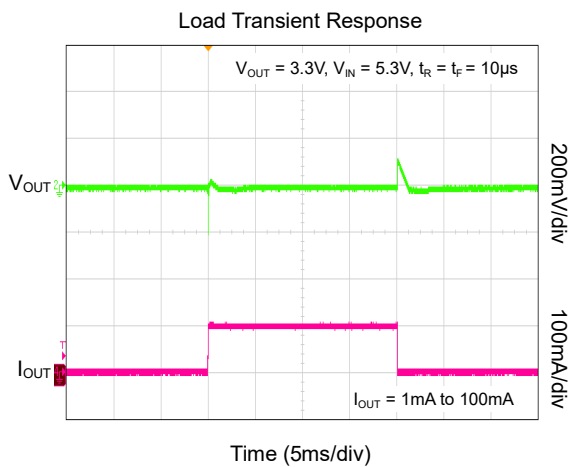
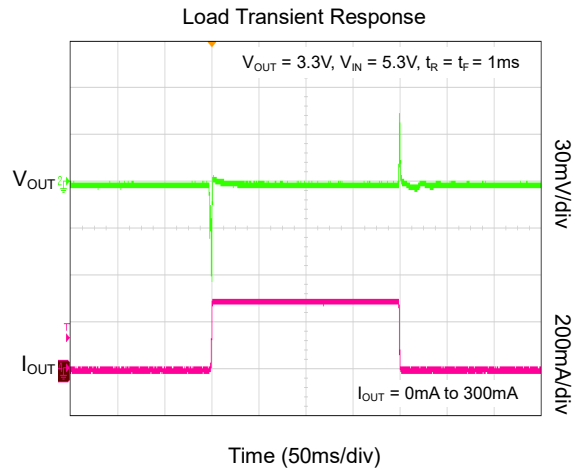
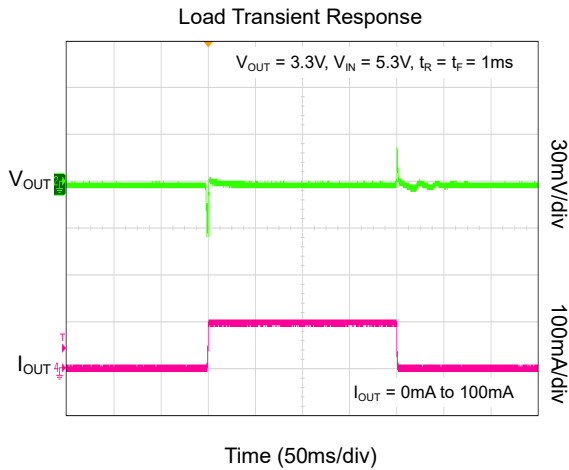
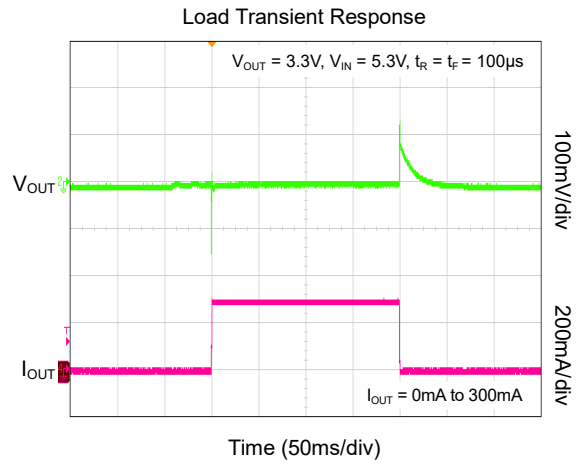
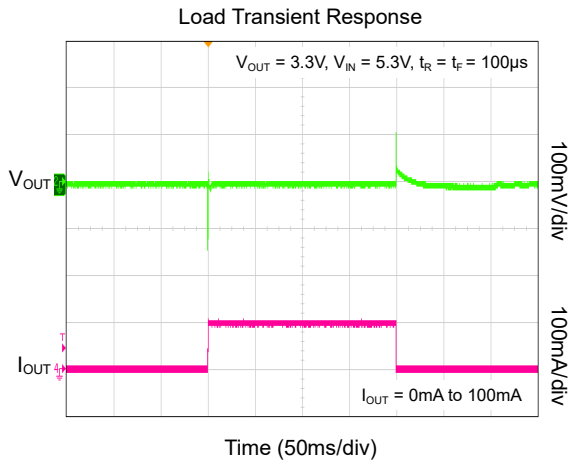

SGM2254xQ Automotive 40V, 300mA, Low Quiescent Current and Low Dropout Voltage Linear Regulator

TYPICAL PERFORMANCE CHARACTERISTICS (continued)

$T_J = +25^\circ\text{C}$, $V_{EN} = V_{IN}$, $C_{IN} = 10\mu\text{F}$, $C_{OUT} = 10\mu\text{F}$, unless otherwise noted.

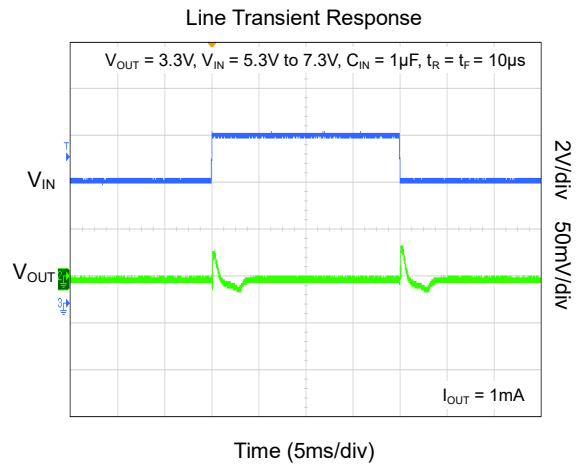
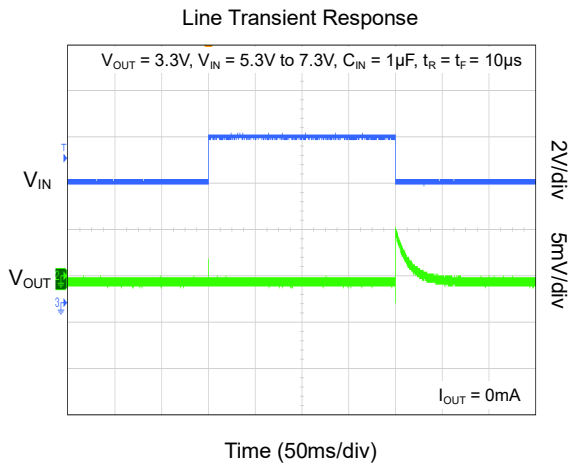
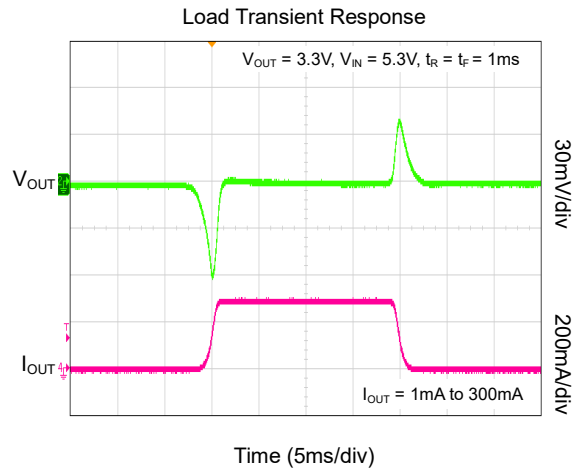
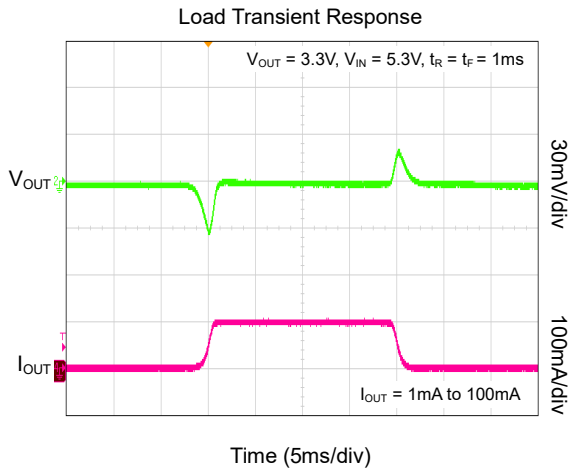
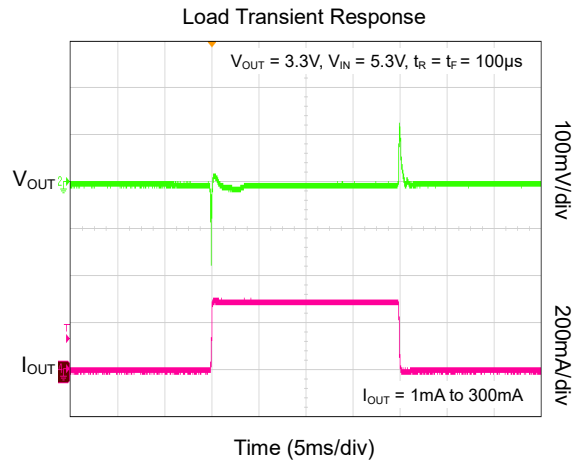
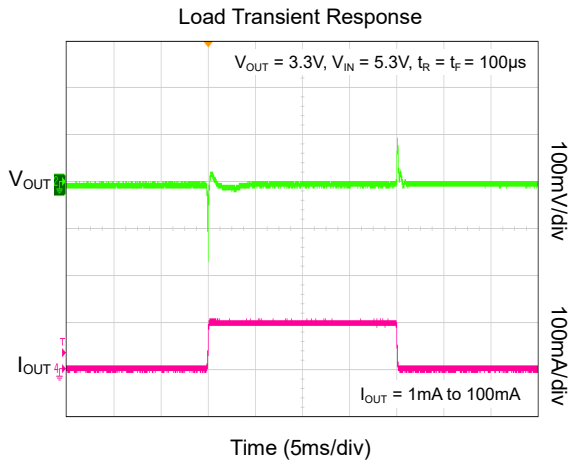

SGM2254xQ Automotive 40V, 300mA, Low Quiescent Current and Low Dropout Voltage Linear Regulator

TYPICAL PERFORMANCE CHARACTERISTICS (continued)

$T_J = +25^\circ\text{C}$, $V_{EN} = V_{IN}$, $C_{IN} = 10\mu\text{F}$, $C_{OUT} = 10\mu\text{F}$, unless otherwise noted.

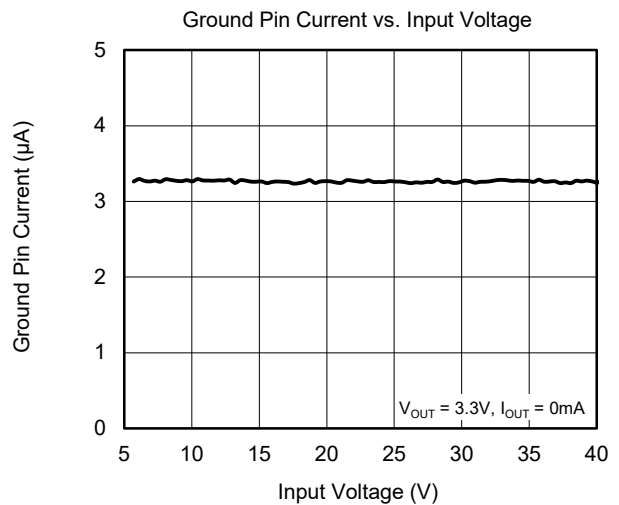
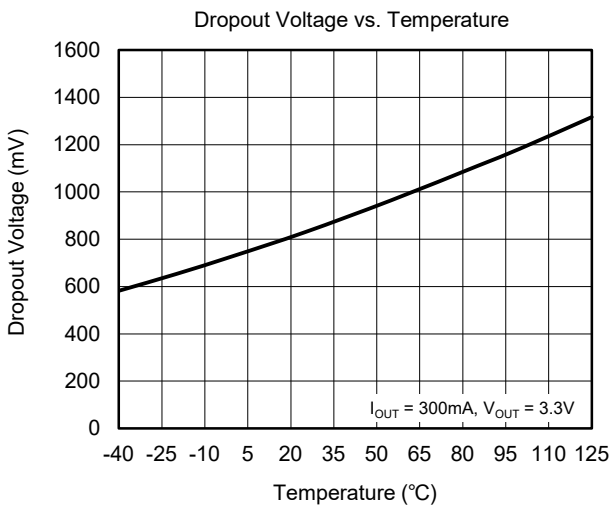
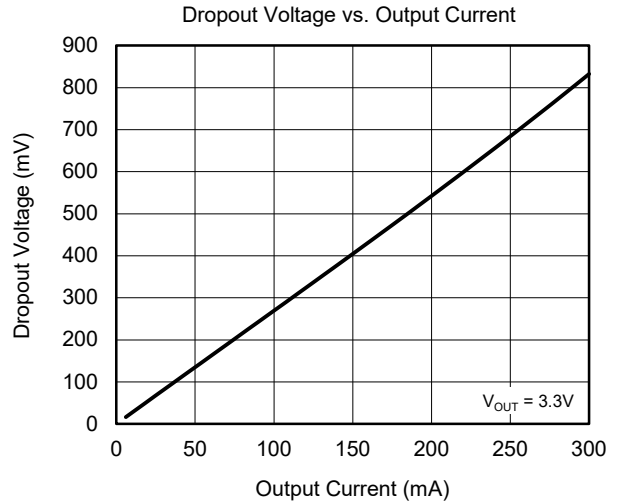
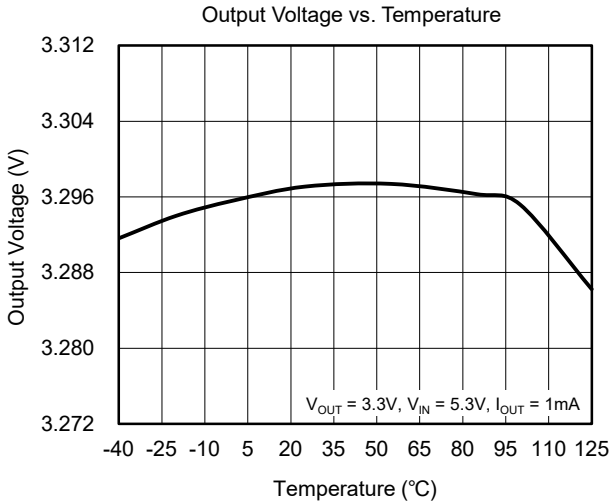
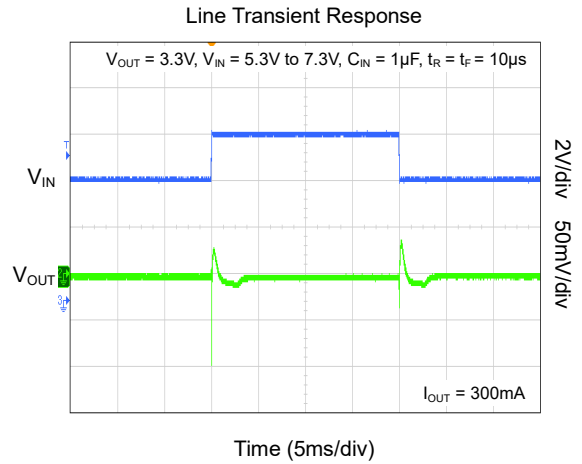
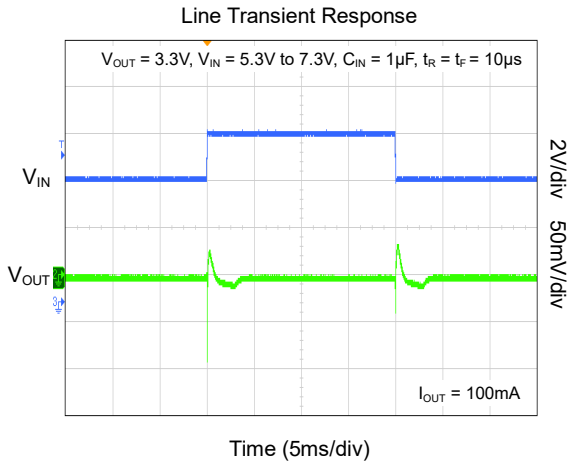

Automotive 40V, 300mA, Low Quiescent Current and Low Dropout Voltage Linear Regulator

SGM2254xQ

TYPICAL PERFORMANCE CHARACTERISTICS (continued)

$T_J = +25^\circ\text{C}$, $V_{EN} = V_{IN}$, $C_{IN} = 10\mu\text{F}$, $C_{OUT} = 10\mu\text{F}$, unless otherwise noted.

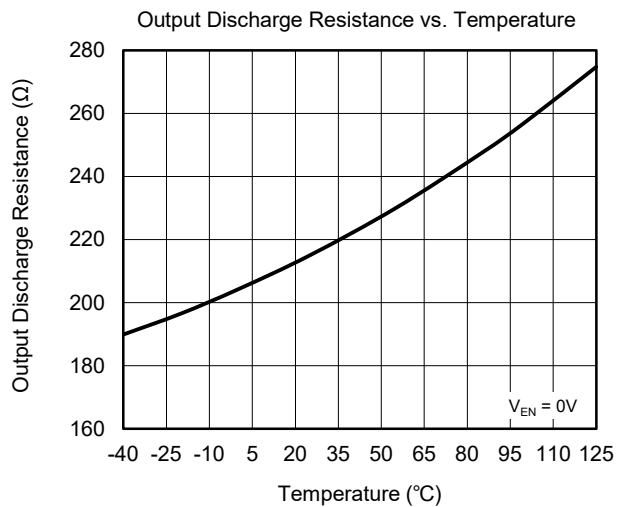
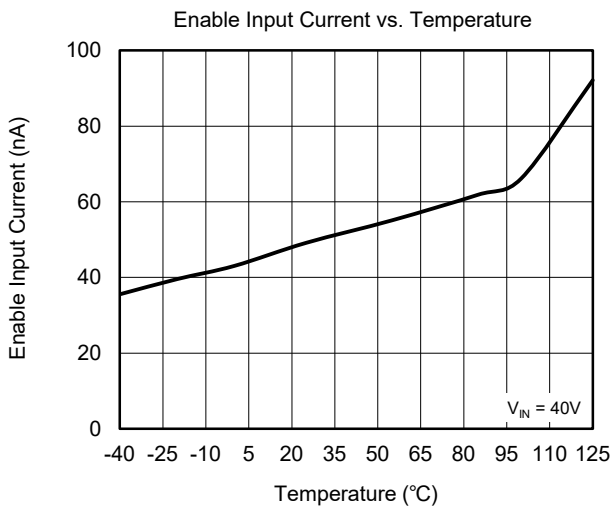
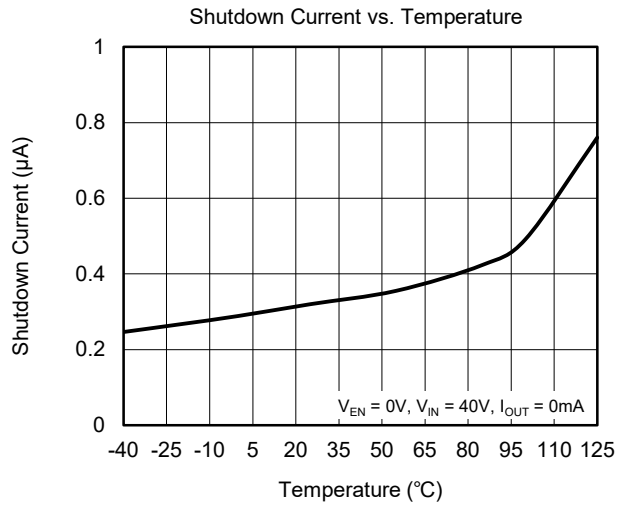
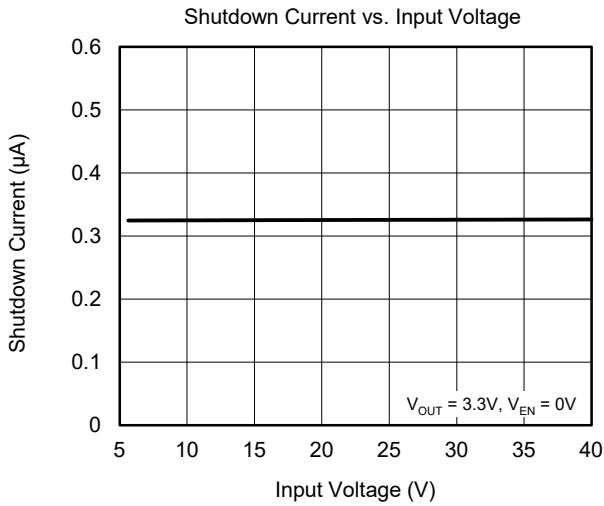
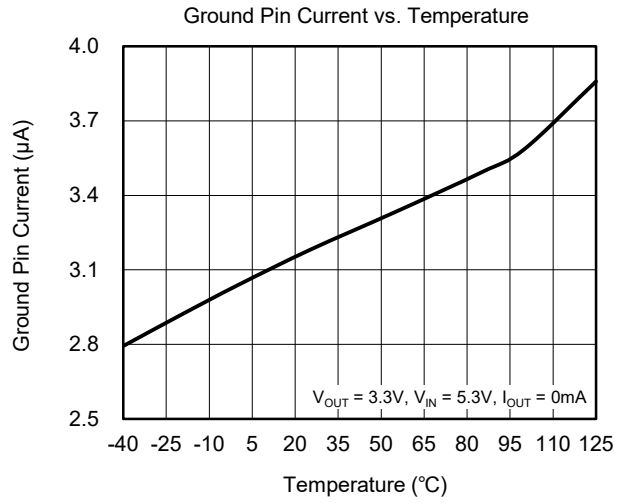
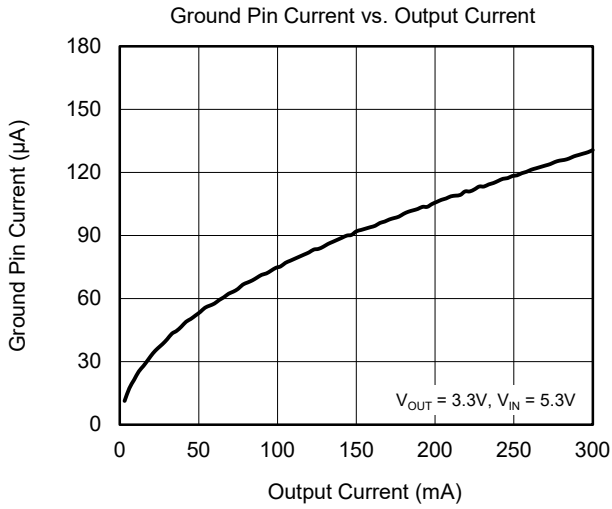

Automotive 40V, 300mA, Low Quiescent Current and Low Dropout Voltage Linear Regulator

SGM2254xQ

TYPICAL PERFORMANCE CHARACTERISTICS (continued)

$T_J = +25^\circ\text{C}$, $V_{EN} = V_{IN}$, $C_{IN} = 10\mu\text{F}$, $C_{OUT} = 10\mu\text{F}$, unless otherwise noted.

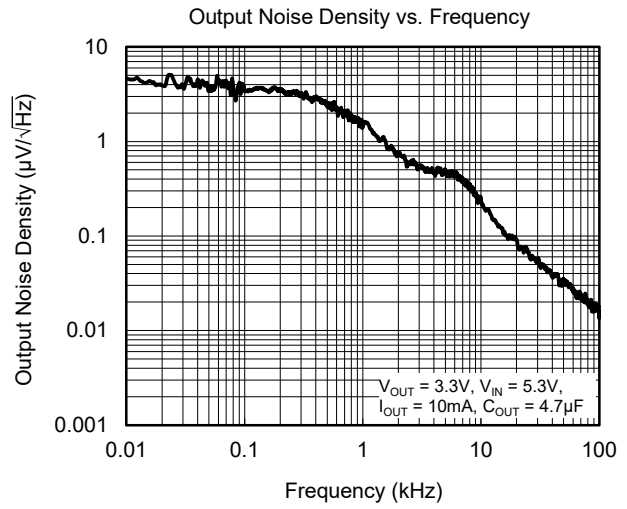
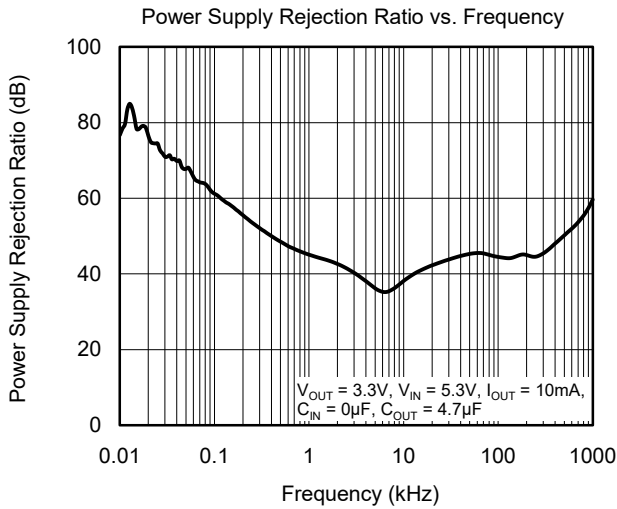
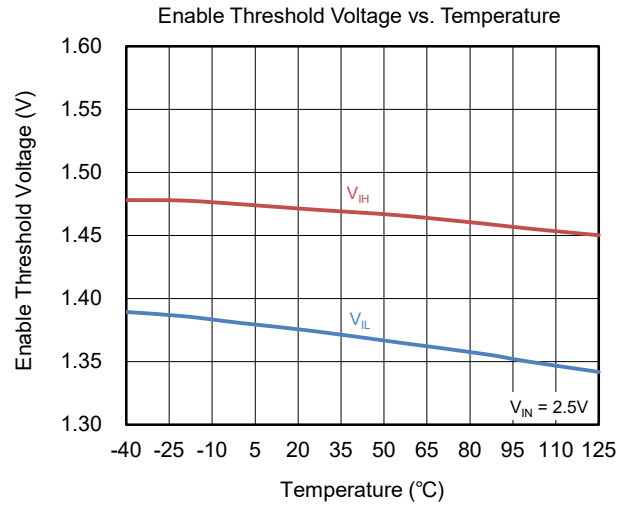
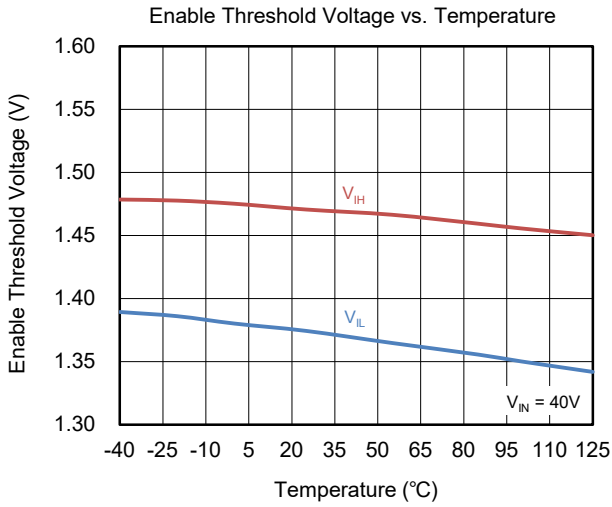

APPLICATION INFORMATION

The SGM2254xQ is a high voltage, low quiescent current and low dropout LDO and provides 300mA output current. These features make the device a reliable solution to solve many challenging problems in the generation of clean and accurate power supply. The high performance also makes the SGM2254xQ useful in a variety of applications. The SGM2254xQ provides protection functions for output overload and overheating.

Input Capacitor Selection (C_{IN})

The input decoupling capacitor should be placed as close as possible to the IN pin to ensure the device stability. 1 μ F or larger X7R or X5R ceramic capacitor is selected to get good dynamic performance.

When V_{IN} is required to provide large current instantaneously, a large effective input capacitor is required. Multiple input capacitors can limit the input tracking inductance. Adding more input capacitors is available to restrict the ringing and to keep it below the device absolute maximum ratings. For C_{OUT} with larger capacitance, it is recommended to choose the larger capacitance C_{IN} .

Output Capacitor Selection (C_{OUT})

One or more output capacitors are required to maintain the stability of the LDO, and the output capacitors should be placed as close as possible to the OUT pin. In addition, in order to obtain the best transient performance, it is recommended to use X7R and X5R ceramic capacitors as output capacitors. Ceramic capacitors have low equivalent series resistance (ESR), excellent temperature and DC bias characteristics. However, it cannot be ignored that the effective capacitance of ceramic capacitors is affected by temperature, DC bias and package size.

For example, Figure 3 shows the capacitance and DC bias and temperature characteristics of 0805, 10V, 10 μ F \pm 10%, X7R capacitor. Therefore, it is necessary to evaluate whether the effective capacitance of the output capacitor can meet the stability requirements of the LDO in practical applications. In general, a capacitor in higher voltage rating and a larger package exhibits better stability, and the effective capacitance can be obtained from the manufacturer datasheet.

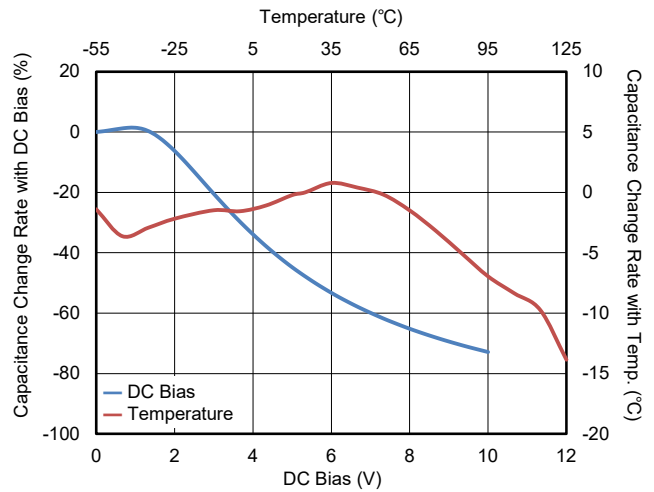

Figure 3. Capacitance vs. DC Bias and Temperature Characteristics

The SGM2254xQ requires a minimum effective capacitance of 1 μ F for C_{OUT} to ensure stability. Additionally, C_{OUT} with larger capacitance and lower ESR will help increase the high frequency PSRR and improve the load transient response.

Enable Operation

The EN pin of the SGM2254xQ is used to enable/disable the device and to deactivate/activate the output automatic discharge function.

When the EN pin voltage is lower than 1V, the device is in shutdown state. There is no current flowing from IN to OUT pins. In this state, the automatic discharge transistor is active to discharge the output voltage through a 215 Ω (TYP) resistor.

When the EN pin voltage is higher than 1.8V, the device is in active state. The output voltage is regulated to the expected value and the automatic discharge transistor is turned off.

Under-Voltage Lockout (UVLO)

The UVLO circuit monitors the input voltage to prevent the device from turning on before V_{IN} rises above the V_{UVLO} threshold. The UVLO circuit responds quickly to glitches on the IN pin and attempts to disable the output of the device if any of these rails collapses. The local input capacitance prevents severe brownouts in most applications.

APPLICATION INFORMATION (continued)

Reverse Current Protection

The PMOS power transistor has an inherent body diode. This body diode will be forward biased when $V_{OUT} > V_{IN}$. When $V_{OUT} > V_{IN}$, the reverse current flowing from the OUT pin to the IN pin will damage the SGM2254xQ. If reverse current protection function is needed in application, the circuit in Figure 4 is good solution to provide reverse current protection.

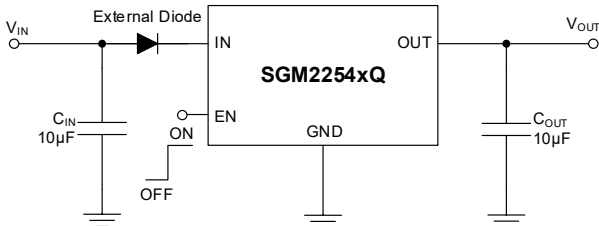

Figure 4. Reverse Protection Reference Design

Output Current Limit Protection

When overload events happen, the output current is internally limited to 755mA (TYP). When the OUT pin is shorted to ground, the output current is internally limited to 265mA (TYP).

Thermal Shutdown

When the die temperature exceeds the threshold value of thermal shutdown, the SGM2254xQ will be in shutdown state and it will remain in this state until the die temperature decreases to +140°C.

Power Dissipation (P_D)

Power dissipation (P_D) of the SGM2254xQ can be calculated by the equation $P_D = (V_{IN} - V_{OUT}) \times I_{OUT}$. The maximum allowable power dissipation (P_{D(MAX)}) of the SGM2254xQ is affected by many factors, including the difference between junction temperature and ambient temperature (T_{J(MAX)} - T_A), package thermal resistance from the junction to the ambient environment (θ_{JA}), the rate of ambient airflow and PCB layout. P_{D(MAX)} can be approximated by the following equation:

$$P_{D(MAX)} = (T_{J(MAX)} - T_A) / \theta_{JA} \quad (1)$$

Layout Guidelines

To get good PSRR, low output noise and high transient response performance, the input and output bypass capacitors must be placed as close as possible to the IN pin and OUT pin separately.

REVISION HISTORY

NOTE: Page numbers for previous revisions may differ from page numbers in the current version.

APRIL 2026 – REV.A to REV.A.1	Page
Added SOT-223-3 Package.....	All
<hr/>	
Changes from Original to REV.A (DECEMBER 2025)	Page
Changed from product preview to production data.....	All

PACKAGE INFORMATION

PACKAGE OUTLINE DIMENSIONS

TDFN-3x3-8JL

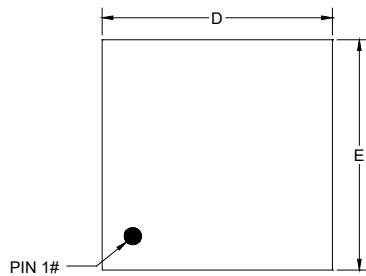

TOP VIEW

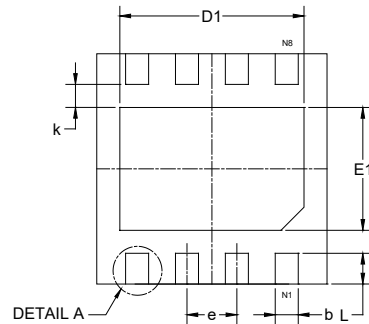

BOTTOM VIEW

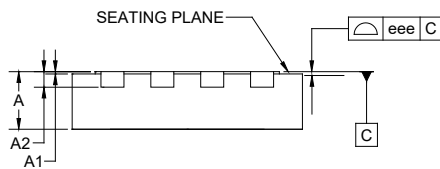

SIDE VIEW

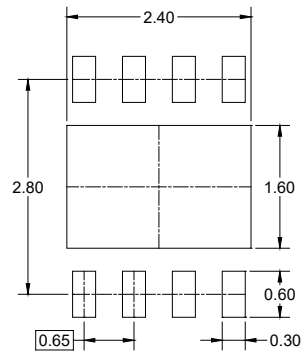
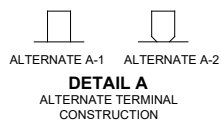

RECOMMENDED LAND PATTERN (Unit: mm)

Symbol	Dimensions In Millimeters		
	MIN	NOM	MAX
A	0.700	-	0.800
A1	0.000	-	0.050
A2	0.203 REF		
b	0.250	-	0.350
D	2.900	-	3.100
D1	2.300	-	2.500
E	2.900	-	3.100
E1	1.500	-	1.700
e	0.650 BSC		
k	0.300 REF		
L	0.300	-	0.500
eee	0.080		

NOTE: This drawing is subject to change without notice.

PACKAGE INFORMATION

PACKAGE OUTLINE DIMENSIONS

SOT-223-3

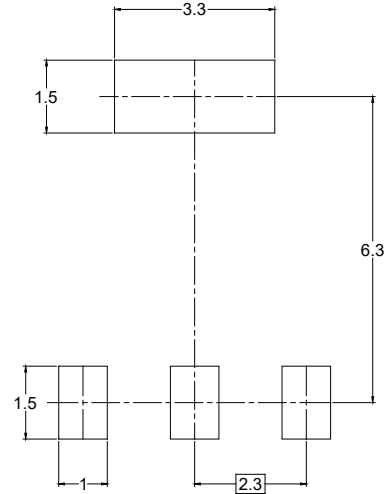
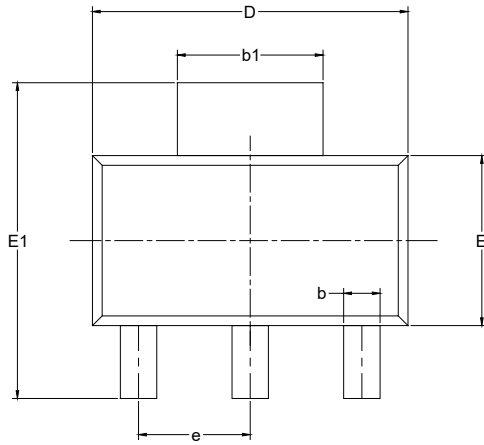

RECOMMENDED LAND PATTERN (Unit: mm)

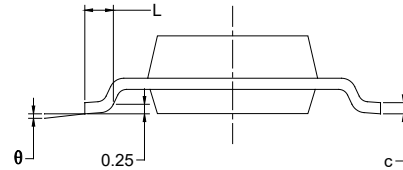
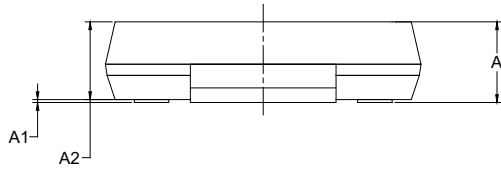

Symbol	Dimensions In Millimeters		Dimensions In Inches	
	MIN	MAX	MIN	MAX
A		1.800		0.071
A1	0.020	0.100	0.001	0.004
A2	1.500	1.700	0.059	0.067
b	0.660	0.840	0.026	0.033
b1	2.900	3.100	0.114	0.122
c	0.230	0.350	0.009	0.014
D	6.300	6.700	0.248	0.264
E	3.300	3.700	0.130	0.146
E1	6.700	7.300	0.264	0.287
e	2.300 BSC		0.091 BSC	
L	0.750		0.030	
θ	0°	10°	0°	10°

NOTES:

1. Body dimensions do not include mode flash or protrusion.
2. This drawing is subject to change without notice.

TAPE AND REEL INFORMATION

REEL DIMENSIONS

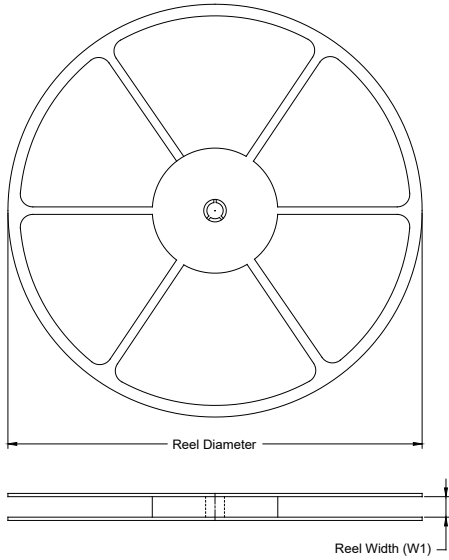

TAPE DIMENSIONS

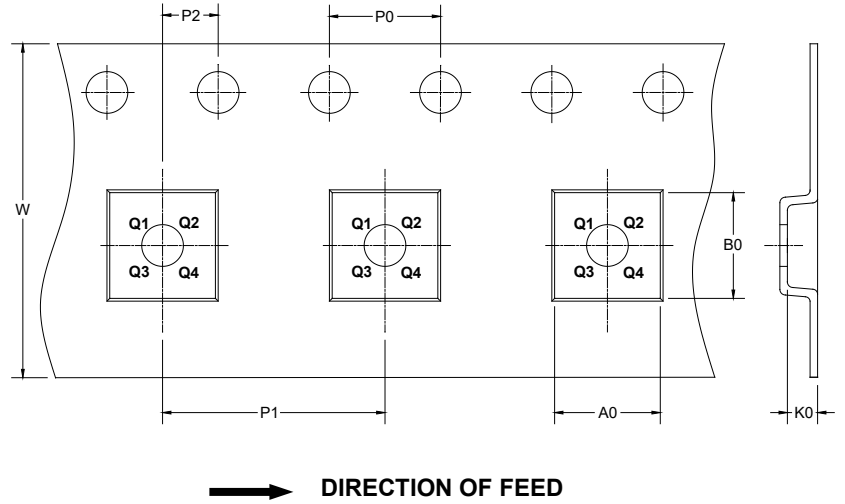

NOTE: The picture is only for reference. Please make the object as the standard.

KEY PARAMETER LIST OF TAPE AND REEL

Package Type	Reel Diameter	Reel Width W1 (mm)	A0 (mm)	B0 (mm)	K0 (mm)	P0 (mm)	P1 (mm)	P2 (mm)	W (mm)	Pin1 Quadrant
TDFN-3×3-8JL	13"	12.4	3.35	3.35	1.13	4.0	8.0	2.0	12.0	Q2
SOT-223-3	13"	12.4	6.55	7.25	1.90	4.0	8.0	2.0	12.0	Q3

DD0001

PACKAGE INFORMATION

CARTON BOX DIMENSIONS

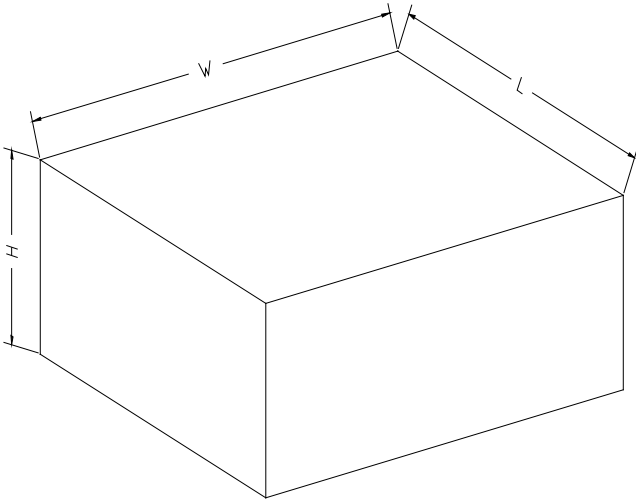

NOTE: The picture is only for reference. Please make the object as the standard.

KEY PARAMETER LIST OF CARTON BOX

Reel Type	Length (mm)	Width (mm)	Height (mm)	Pizza/Carton
13"	386	280	370	5

DD0002