



SGM13005H4

Low Noise Amplifier with Bypass Switch for LTE High Band

GENERAL DESCRIPTION

The SGM13005H4 is a low noise amplifier (LNA) with bypass for LTE high band receiving application. The device features high gain, low noise figure and high linearity over a supply voltage range from 1.5V to 3.6V. Low noise figure and high gain improve the sensitivity of the SGM13005H4, and high linearity enables the device to provide better immunity to interference signals.

No external DC blocking capacitors are required on the RF paths as long as no external DC voltage is applied, which can save PCB area and cost.

The SGM13005H4 is available in a Green UTDFN-1.1×0.7-6L package.

APPLICATIONS

- Cell Phones
- Tablets
- Other RF Front-End Modules

FEATURES

- **Operating Frequency Range: 2300MHz to 2700MHz**
- **High Gain: 18.7dB at 2500MHz**
- **Low Noise Figure: 0.9dB at 2500MHz**
- **Low Operation Current: 15.0mA**
- **Bypass Mode Current: 1µA (MAX)**
- **Single Supply Voltage Range: 1.5V to 3.6V**
- **Input and Output DC Decoupled**
- **Integrated Matching for the Output**
- **Available in a Green UTDFN-1.1×0.7-6L Package**

BLOCK DIAGRAM

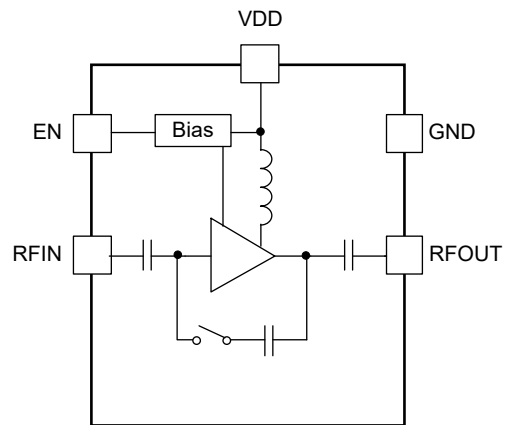

Figure 1. SGM13005H4 Block Diagram

PACKAGE/ORDERING INFORMATION

MODEL	PACKAGE DESCRIPTION	SPECIFIED TEMPERATURE RANGE	ORDERING NUMBER	PACKAGE MARKING	PACKING OPTION
SGM13005H4	UTDFN-1.1×0.7-6L	-40°C to +85°C	SGM13005H4YUEC6G/TR	6Q	Tape and Reel, 10000

MARKING INFORMATION

NOTE: Fixed character for 6Q.

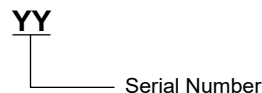

Green (RoHS & HSF): SG Micro Corp defines "Green" to mean Pb-Free (RoHS compatible) and free of halogen substances. If you have additional comments or questions, please contact your SGMICRO representative directly.

ABSOLUTE MAXIMUM RATINGS

Supply Voltage, V_{DD}	-0.3V to 4.0V
EN to GND.....	-0.3V to 3.6V
RFIN, RFOUT to GND.....	-0.3V to 0.3V
Supply Maximum Current, I_{VDD}	30mA
RF Input Power, P_{IN}	18dBm
Junction Temperature.....	+150°C
Storage Temperature Range.....	-55°C to +150°C
Lead Temperature (Soldering, 10s).....	+260°C
ESD Susceptibility ^{(1) (2)}	
HBM.....	±1500V
CDM.....	±2000V

NOTES:

1. For human body model (HBM), all pins comply with ANSI/ESDA/JEDEC JS-001 specifications.
2. For charged device model (CDM), all pins comply with ANSI/ESDA/JEDEC JS-002 specifications.

RECOMMENDED OPERATING CONDITIONS

Operating Frequency Range, f_0	2300MHz to 2700MHz
Operating Temperature Range.....	-40°C to +85°C
Supply Voltage, V_{DD}	1.5V to 3.6V
Control High Voltage, V_{CTL_H}	1.35V to V_{DD}
Control Low Voltage, V_{CTL_L}	0V to 0.45V

OVERSTRESS CAUTION

Stresses beyond those listed in Absolute Maximum Ratings may cause permanent damage to the device. Exposure to absolute maximum rating conditions for extended periods may affect reliability. Functional operation of the device at any conditions beyond those indicated in the Recommended Operating Conditions section is not implied.

ESD SENSITIVITY CAUTION

This integrated circuit can be damaged if ESD protections are not considered carefully. SGMICRO recommends that all integrated circuits be handled with appropriate precautions. Failure to observe proper handling and installation procedures can cause damage. ESD damage can range from subtle performance degradation to complete device failure. Precision integrated circuits may be more susceptible to damage because even small parametric changes could cause the device not to meet the published specifications.

DISCLAIMER

SG Micro Corp reserves the right to make any change in circuit design, or specifications without prior notice.

PIN CONFIGURATION

(TOP VIEW)

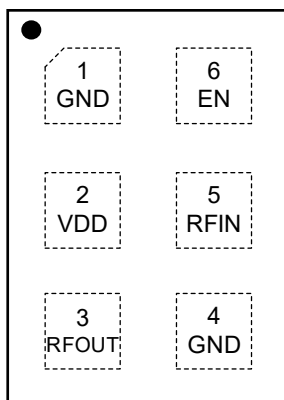

UTDFN-1.1×0.7-6L

PIN DESCRIPTION

PIN	NAME	FUNCTION
1, 4	GND	Ground.
2	VDD	Power Supply.
3	RFOUT	LNA Output.
5	RFIN	LNA Input from Antenna.
6	EN	Active High Enable Input for the Device. Pull high to enable, pull low into bypass mode.

ELECTRICAL CHARACTERISTICS

($T_A = +25^\circ\text{C}$, $V_{DD} = 1.5\text{V}$ to 3.6V , $f_0 = 2300\text{MHz}$ to 2700MHz , typical values are at $V_{DD} = 2.8\text{V}$, input and output resistance = 50Ω , unless otherwise noted.)

PARAMETER	SYMBOL	CONDITIONS	MIN	TYP	MAX	UNITS
DC Characteristics						
Supply Voltage	V_{DD}		1.5		3.6	V
Supply Current	I_{VDD}	EN = High		15.0	16.4	mA
Control Voltage	V_{CTL_H}	High	1.35	1.8	V_{DD}	V
	V_{CTL_L}	Low	0	0	0.45	
RF Characteristics						
Power Gain	G	$f_0 = 2300\text{MHz}$	16.1	18.4		dB
		$f_0 = 2500\text{MHz}$	17.9	18.7		
		$f_0 = 2700\text{MHz}$	17.4	18.2		
Input Return Loss	RL_I	$f_0 = 2300\text{MHz}$		5.8		dB
		$f_0 = 2500\text{MHz}$		7.1		
		$f_0 = 2700\text{MHz}$		8.1		
Output Return Loss	RL_O	$f_0 = 2300\text{MHz}$		7.2		dB
		$f_0 = 2500\text{MHz}$		13.8		
		$f_0 = 2700\text{MHz}$		14.9		
Reverse Isolation	ISO	$f_0 = 2300\text{MHz}$		29.8		dB
		$f_0 = 2500\text{MHz}$		28.7		
		$f_0 = 2700\text{MHz}$		29.1		
Noise Figure	NF	$f_0 = 2300\text{MHz}$		0.8		dB
		$f_0 = 2500\text{MHz}$		0.9		
		$f_0 = 2700\text{MHz}$		0.9		
Input Power 1dB Compression Point	P_{1dB}	$f_0 = 2300\text{MHz}$		-9.5		dBm
		$f_0 = 2500\text{MHz}$		-9.1		
		$f_0 = 2700\text{MHz}$		-8.0		
Input In-Band IP3	IIP3_inb	$f_1 = 2300\text{MHz}$, $f_2 = 2301\text{MHz}$, $P_1 = P_2 = -25\text{dBm}$		1.2		dBm
		$f_1 = 2500\text{MHz}$, $f_2 = 2501\text{MHz}$, $P_1 = P_2 = -25\text{dBm}$		1.3		
		$f_1 = 2700\text{MHz}$, $f_2 = 2701\text{MHz}$, $P_1 = P_2 = -25\text{dBm}$		2.4		
Turn-On Time	t_{ON}	Time from EN on to 90% of the gain		1.4	1.6	μs
Turn-Off Time	t_{OFF}	Time from EN off to 10% of the gain		0.06	0.50	μs
Bypass Mode						
Supply Current	I_{VDD}	$V_{EN} < 0.45\text{V}$		0.2	1	μA
Insertion Loss	IL	$f_0 = 2300\text{MHz}$		5.2	5.9	dB
		$f_0 = 2500\text{MHz}$		5.0	5.7	
		$f_0 = 2700\text{MHz}$		5.5	6.2	
Input Return Loss	RL_I	$f_0 = 2300\text{MHz}$		26.4		dB
		$f_0 = 2500\text{MHz}$		13.1		
		$f_0 = 2700\text{MHz}$		7.9		
Output Return Loss	RL_O	$f_0 = 2300\text{MHz}$		7.4		dB
		$f_0 = 2500\text{MHz}$		8.7		
		$f_0 = 2700\text{MHz}$		7.3		

ELECTRICAL CHARACTERISTICS (Continued)

($T_A = +25^\circ\text{C}$, $V_{DD} = 1.5\text{V}$ to 3.6V , $f_0 = 2300\text{MHz}$ to 2700MHz , typical values are at $V_{DD} = 1.8\text{V}$, input and output resistance = 50Ω , unless otherwise noted.)

PARAMETER	SYMBOL	CONDITIONS	MIN	TYP	MAX	UNITS
DC Characteristics						
Supply Voltage	V_{DD}		1.5		3.6	V
Supply Current	I_{VDD}	EN = High		14.7	16.1	mA
Control Voltage	V_{CTL_H}	High	1.35	1.8	V_{DD}	V
	V_{CTL_L}	Low	0	0	0.45	
RF Characteristics						
Power Gain	G	$f_0 = 2300\text{MHz}$	16.0	18.3		dB
		$f_0 = 2500\text{MHz}$	17.8	18.5		
		$f_0 = 2700\text{MHz}$	17.0	17.9		
Input Return Loss	RL_I	$f_0 = 2300\text{MHz}$		5.7		dB
		$f_0 = 2500\text{MHz}$		7.0		
		$f_0 = 2700\text{MHz}$		7.9		
Output Return Loss	RL_O	$f_0 = 2300\text{MHz}$		7.6		dB
		$f_0 = 2500\text{MHz}$		9.0		
		$f_0 = 2700\text{MHz}$		7.6		
Reverse Isolation	ISO	$f_0 = 2300\text{MHz}$		29.2		dB
		$f_0 = 2500\text{MHz}$		28.5		
		$f_0 = 2700\text{MHz}$		28.6		
Noise Figure	NF	$f_0 = 2300\text{MHz}$		0.8		dB
		$f_0 = 2500\text{MHz}$		0.9		
		$f_0 = 2700\text{MHz}$		0.9		
Input Power 1dB Compression Point	P_{1dB}	$f_0 = 2300\text{MHz}$		-12.5		dBm
		$f_0 = 2500\text{MHz}$		-12.3		
		$f_0 = 2700\text{MHz}$		-11.1		
Input In-Band IP3	IIP3_inb	$f_1 = 2300\text{MHz}$, $f_2 = 2301\text{MHz}$, $P_1 = P_2 = -25\text{dBm}$		-1.4		dBm
		$f_1 = 2500\text{MHz}$, $f_2 = 2501\text{MHz}$, $P_1 = P_2 = -25\text{dBm}$		-2.4		
		$f_1 = 2700\text{MHz}$, $f_2 = 2701\text{MHz}$, $P_1 = P_2 = -25\text{dBm}$		-0.6		
Turn-On Time	t_{ON}	Time from EN on to 90% of the gain		1.5	1.7	μs
Turn-Off Time	t_{OFF}	Time from EN off to 10% of the gain		0.09	0.50	μs
Bypass Mode						
Supply Current	I_{VDD}	$V_{EN} < 0.45\text{V}$		0.2	1	μA
Insertion Loss	IL	$f_0 = 2300\text{MHz}$		5.7	6.4	dB
		$f_0 = 2500\text{MHz}$		5.5	6.2	
		$f_0 = 2700\text{MHz}$		6.1	6.8	
Input Return Loss	RL_I	$f_0 = 2300\text{MHz}$		21.2		dB
		$f_0 = 2500\text{MHz}$		12.5		
		$f_0 = 2700\text{MHz}$		7.8		
Output Return Loss	RL_O	$f_0 = 2300\text{MHz}$		7.6		dB
		$f_0 = 2500\text{MHz}$		9.0		
		$f_0 = 2700\text{MHz}$		7.6		

TYPICAL APPLICATION CIRCUIT

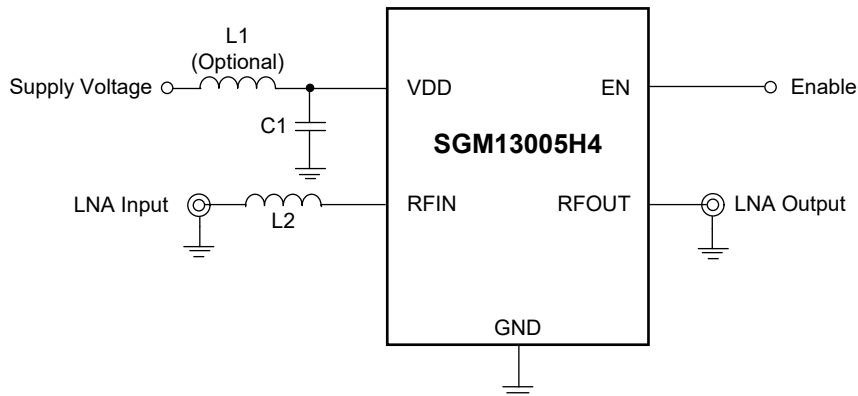

Figure 2. SGM13005H4 Typical Application Circuit

Table 1. Inductor Selection Table

Part	Typical (nH)	Q (min)	Frequency (MHz)	MFR	Size
LQW15A	4.7	25	250	Murata	0402

Table 2. Capacitor Selection Table

Part	Typical (pF)	Voltage (V)	MFR	Size
GRM155	1000	50	Murata	0402

EVALUATION BOARD LAYOUT

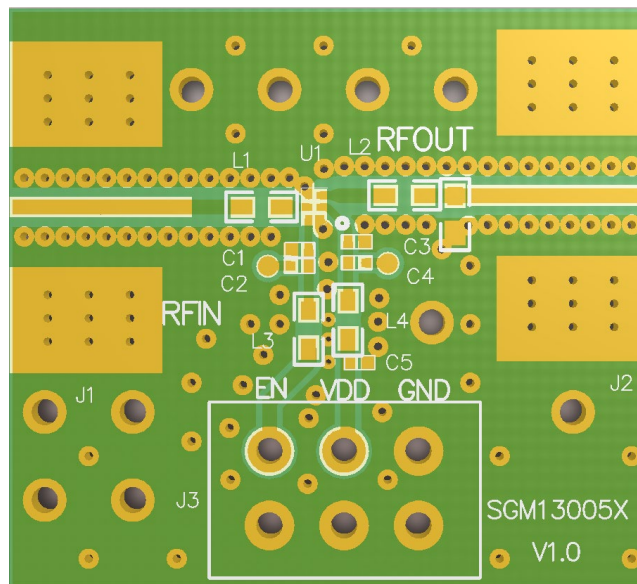

Figure 3. SGM13005H4 Evaluation Board Layout

REVISION HISTORY

NOTE: Page numbers for previous revisions may differ from page numbers in the current version.

SEPTEMBER 2025 – REV.A.1 to REV.A.2	Page
Updated Package Outline Dimensions.....	8

APRIL 2024 – REV.A to REV.A.1	Page
Updated Electrical Characteristics section.....	4, 5

Changes from Original (DECEMBER 2022) to REV.A	Page
Changed from product preview to production data.....	All

PACKAGE OUTLINE DIMENSIONS

UTDFN-1.1×0.7-6L

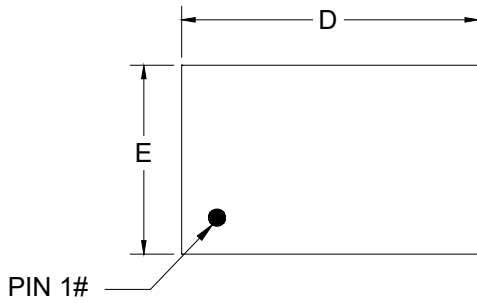

TOP VIEW

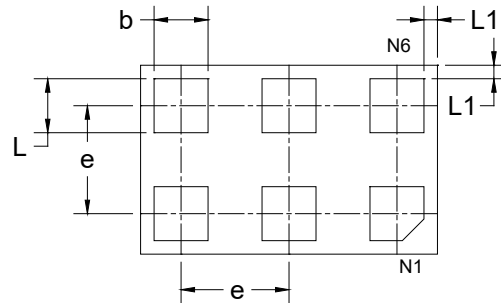

BOTTOM VIEW

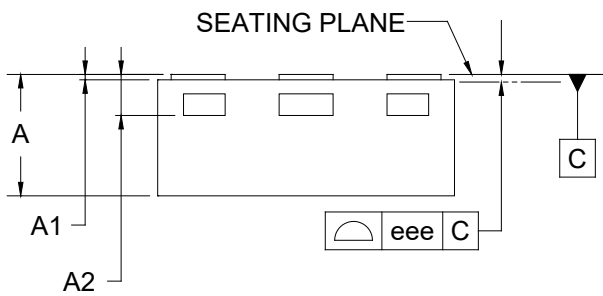

SIDE VIEW

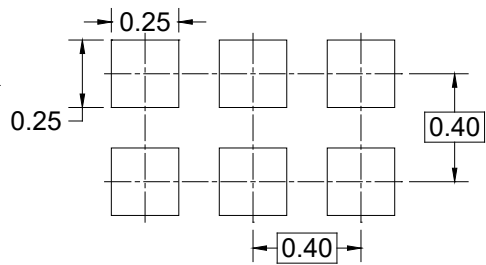

RECOMMENDED LAND PATTERN (Unit: mm)

Symbol	Dimensions In Millimeters		
	MIN	NOM	MAX
A	0.400	-	0.500
A1	0.000	-	0.050
A2	0.152 REF		
b	0.150	-	0.250
D	1.050	-	1.150
E	0.650	-	0.750
e	0.400 BSC		
L	0.150	-	0.250
L1	0.000	-	0.100
eee	0.080		

NOTE: This drawing is subject to change without notice.

PACKAGE INFORMATION

TAPE AND REEL INFORMATION

REEL DIMENSIONS

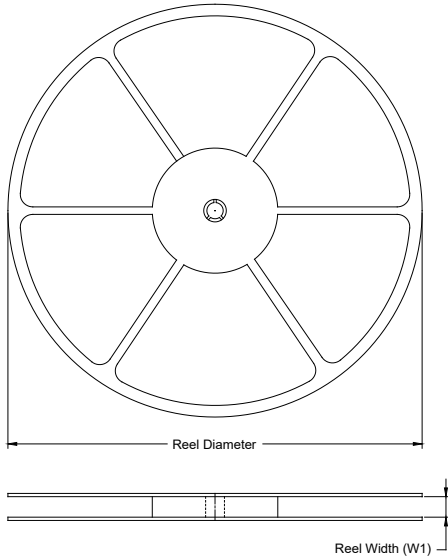

TAPE DIMENSIONS

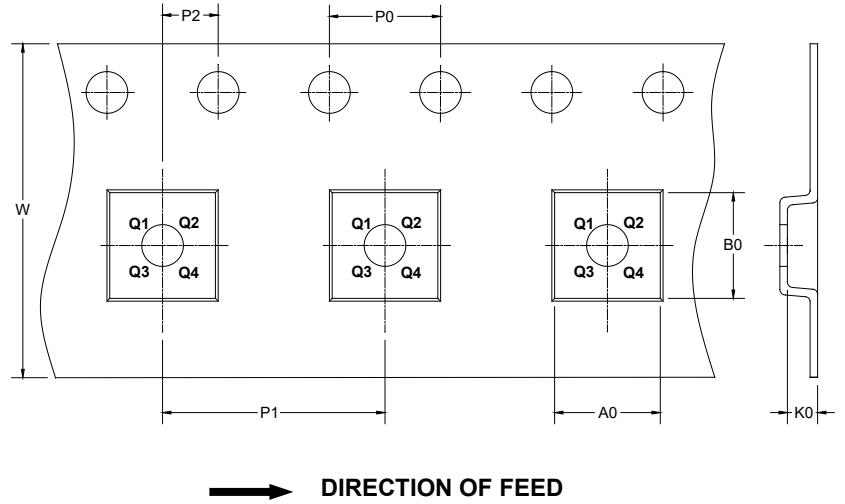

NOTE: The picture is only for reference. Please make the object as the standard.

KEY PARAMETER LIST OF TAPE AND REEL

Package Type	Reel Diameter	Reel Width W1 (mm)	A0 (mm)	B0 (mm)	K0 (mm)	P0 (mm)	P1 (mm)	P2 (mm)	W (mm)	Pin1 Quadrant
UTDFN-1.1×0.7-6L	7"	9.5	0.80	1.20	0.55	4.0	2.0	2.0	8.0	Q1

DD0001

PACKAGE INFORMATION

CARTON BOX DIMENSIONS

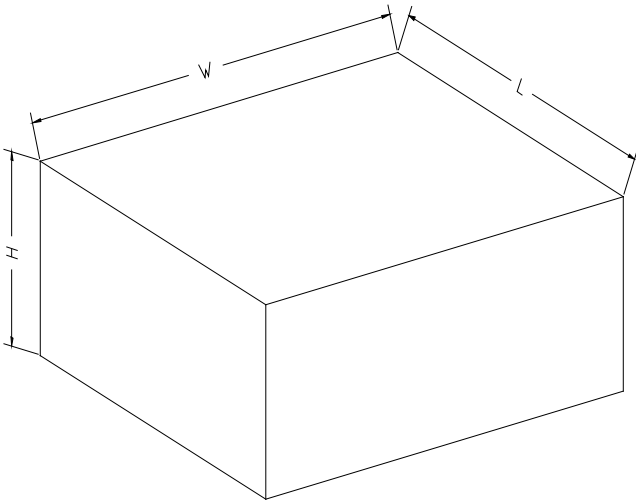

NOTE: The picture is only for reference. Please make the object as the standard.

KEY PARAMETER LIST OF CARTON BOX

Reel Type	Length (mm)	Width (mm)	Height (mm)	Pizza/Carton
7" (Option)	368	227	224	8
7"	442	410	224	18

D00002