

GENERAL DESCRIPTION

The SGM706B is an integrated microprocessor supervisory device. Compared with the design using a single IC or discrete components, this integration design has the advantage of improving system stability and accuracy. The SGM706B can be reset under power-up, power-down or even voltage reduction brownout conditions. When V_{CC} is as low as 1V, the reset output can still operate. And it also has a low-level active manual reset nMR function.

The SGM706B provides an independent watchdog monitoring circuit, which is activated when its WDI input has not toggled for more than 1.6s.

When the power supply fails, the battery power is low, or the additional power supply needs to be monitored, it can be realized by the 1.25V threshold detector of the SGM706B.

The SGM706B is available in Green UTDFN-1.5×1.5-8L, SOIC-8 and MSOP-8 packages. It operates over an junction temperature range of -40°C to +125°C.

TYPICAL APPLICATION

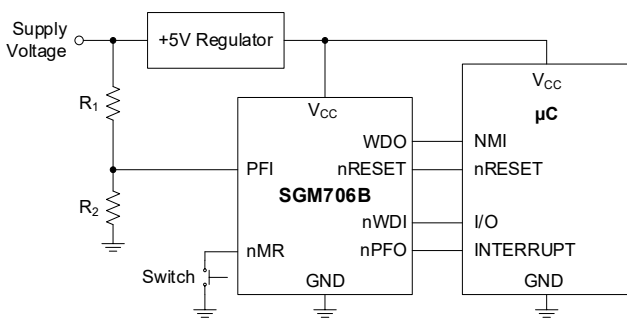

Figure 1. Typical Application Circuit

FEATURES

- Ultra-Low Supply Current: < 1µA (TYP)
- Precision Supply-Voltage Monitor
 - 4.63V for SGM706B-L
 - 4.38V for SGM706B-M
 - 4.0V for SGM706B-J
 - 3.08V for SGM706B-T
 - 2.93V for SGM706B-S
 - 2.63V for SGM706B-R
- Guaranteed nRESET Valid at $V_{CC} = 1V$
- 200ms Reset Pulse Width
- Debounced TTL/CMOS-Compatible
- Manual Reset Input
- Watchdog Timer with 1.6s Timeout
- Voltage Monitor for Power-Fail or Low-Battery Warning
- -40°C to +125°C Operating Temperature Range
- Available in Green UTDFN-1.5×1.5-8L, SOIC-8 and MSOP-8 Packages

APPLICATIONS

- Computers
- Battery-Powered Applications
- Portable Equipment
- Automotive Equipment
- Safety Systems
- Intelligent Instruments
- Critical µC Power Monitoring
- Microprocessor Systems

PACKAGE/ORDERING INFORMATION

MODEL	RESET THRESHOLD (V)	PACKAGE DESCRIPTION	ORDERING NUMBER	PACKAGE MARKING	PACKING OPTION
SGM706B	4.63	UTDFN-1.5×1.5-8L	SGM706B-LXUDW8G/TR	CK0 XXX	Tape and Reel, 4000
	4.63	SOIC-8	SGM706B-LXS8G/TR	SGM 706BLXS8 XXXXX	Tape and Reel, 4000
	4.63	MSOP-8	SGM706B-LXMS8G/TR	SGM706BL XMS8 XXXXX	Tape and Reel, 4000
	4.38	UTDFN-1.5×1.5-8L	SGM706B-MXUDW8G/TR	CK1 XXX	Tape and Reel, 4000
	4.38	SOIC-8	SGM706B-MXS8G/TR	SGM 706BMXS8 XXXXX	Tape and Reel, 4000
	4.38	MSOP-8	SGM706B-MXMS8G/TR	SGM706BM XMS8 XXXXX	Tape and Reel, 4000
	4.0	UTDFN-1.5×1.5-8L	SGM706B-JXUDW8G/TR	CK2 XXX	Tape and Reel, 4000
	4.0	SOIC-8	SGM706B-JXS8G/TR	SGM 706BJXS8 XXXXX	Tape and Reel, 4000
	4.0	MSOP-8	SGM706B-JXMS8G/TR	SGM706BJ XMS8 XXXXX	Tape and Reel, 4000
	3.08	UTDFN-1.5×1.5-8L	SGM706B-TXUDW8G/TR	CG5 XXX	Tape and Reel, 4000
	3.08	SOIC-8	SGM706B-TXS8G/TR	SGM 706BTXS8 XXXXX	Tape and Reel, 4000
	3.08	MSOP-8	SGM706B-TXMS8G/TR	SGM706BT XMS8 XXXXX	Tape and Reel, 4000
	2.93	UTDFN-1.5×1.5-8L	SGM706B-SXUDW8G/TR	CBE XXX	Tape and Reel, 4000
	2.93	SOIC-8	SGM706B-SXS8G/TR	SGM 706BSXS8 XXXXX	Tape and Reel, 4000
	2.93	MSOP-8	SGM706B-SXMS8G/TR	SGM706BS XMS8 XXXXX	Tape and Reel, 4000
	2.63	UTDFN-1.5×1.5-8L	SGM706B-RXUDW8G/TR	CG4 XXX	Tape and Reel, 4000
	2.63	SOIC-8	SGM706B-RXS8G/TR	SGM 706BRXS8 XXXXX	Tape and Reel, 4000
	2.63	MSOP-8	SGM706B-RXMS8G/TR	SGM706BR XMS8 XXXXX	Tape and Reel, 4000

PACKAGE/ORDERING INFORMATION (continued)

MARKING INFORMATION

NOTE: XXX = Date Code and Trace Code. XXXXX = Date Code, Trace Code and Vendor Code.

UTDFN-1.5×1.5-8L

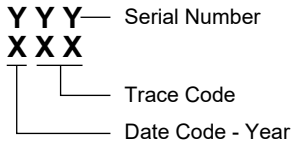

SOIC-8/MSOP-8

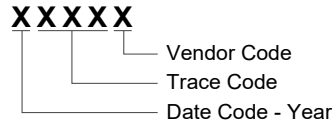

Green (RoHS & HSF): SG Micro Corp defines "Green" to mean Pb-Free (RoHS compatible) and free of halogen substances. If you have additional comments or questions, please contact your SGMICRO representative directly.

ABSOLUTE MAXIMUM RATINGS

Terminal Voltage (With Respect to GND)

V_{CC} -0.3V to 6.0V
All Other Inputs -0.3V to (V_{CC} + 0.3V)

Input Current

V_{CC} 20mA
GND 20mA

Output Current

All Outputs 20mA

Package Thermal Resistance

UTDFN-1.5×1.5-8L, θ_{JA} 156.7°C/W
UTDFN-1.5×1.5-8L, θ_{JB} 113.6°C/W
UTDFN-1.5×1.5-8L, θ_{JC(TOP)} 122°C/W
UTDFN-1.5×1.5-8L, θ_{JC(BOT)} 88.6°C/W
SOIC-8, θ_{JA} 146.8°C/W
SOIC-8, θ_{JB} 94.3°C/W
SOIC-8, θ_{JC} 93.1°C/W
MSOP-8, θ_{JA} 178°C/W
MSOP-8, θ_{JB} 120.6°C/W
MSOP-8, θ_{JC} 86.8°C/W

Junction Temperature +150°C
Storage Temperature Range -65°C to +150°C
Lead Temperature (Soldering, 10s) +260°C

ESD Susceptibility

HBM ±4000V
MM ±400V
CDM ±1000V

OVERSTRESS CAUTION

Stresses beyond those listed in Absolute Maximum Ratings may cause permanent damage to the device. Exposure to absolute maximum rating conditions for extended periods may affect reliability. Functional operation of the device at any conditions beyond those indicated in the Recommended Operating Conditions section is not implied.

ESD SENSITIVITY CAUTION

This integrated circuit can be damaged if ESD protections are not considered carefully. SGMICRO recommends that all integrated circuits be handled with appropriate precautions. Failure to observe proper handling and installation procedures can cause damage. ESD damage can range from subtle performance degradation to complete device failure. Precision integrated circuits may be more susceptible to damage because even small parametric changes could cause the device not to meet the published specifications.

DISCLAIMER

SG Micro Corp reserves the right to make any change in circuit design, or specifications without prior notice.

RECOMMENDED OPERATING CONDITIONS

Ambient Temperature Range -40°C to +125°C

PIN CONFIGURATIONS

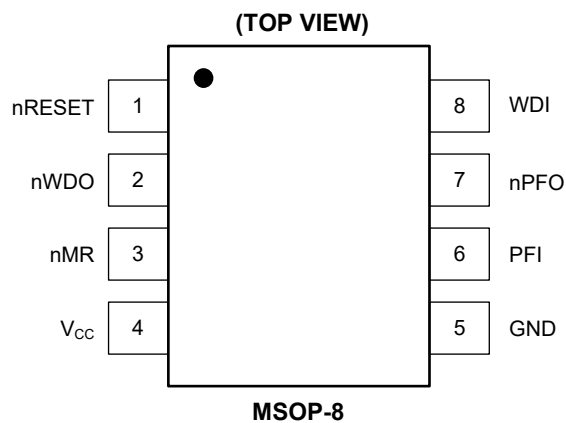
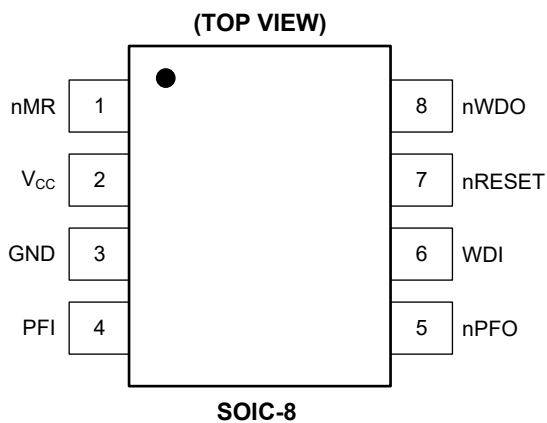
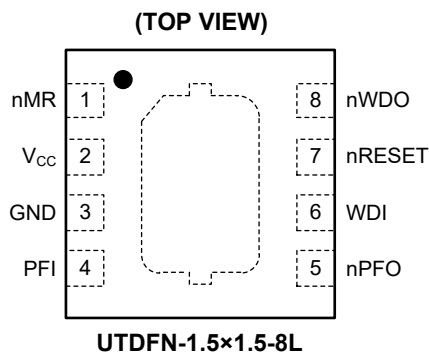

PIN DESCRIPTION

PIN			NAME	FUNCTION
UTDFN- 1.5×1.5-8L	SOIC-8	MSOP-8		
1	1	3	nMR	Manual Reset Input Pin. It is an active-low reset input with an internal 234µA ($V_{CC} = +5V$) pull-up current. nMR can be driven by a CMOS/TTL logic or by a switch shorting to GND. If not used, leave it open or connect it to V_{CC} .
2	2	4	V_{CC}	Supply Voltage Pin.
3	3	5	GND	Ground.
4	4	6	PFI	Power-Fail Voltage Monitor Input Pin. nPFO goes low when PFI is lower than 1.25V. If not used, connect PFI to GND or V_{CC} .
5	5	7	nPFO	Power-Fail Voltage Monitor Output Pin. nPFO goes low when PFI is lower than 1.25V. nPFO remains high when PFI is more than 1.25V.
6	6	8	WDI	Watchdog Input Pin. If the WDI remains high or low for longer than the watchdog timeout period (1.6s, TYP), the internal watchdog timer will expire and nWDO will go low. The internal watchdog timer is kept clear while a reset is asserted or WDI is three-stated. The timer is also cleared if the WDI input is changed (on rising or falling edges). The watchdog feature is disabled if the WDI is left open or if it is connected to a three-stated buffer output. If it requires the SGM706B to switch WDI from normal state to disable state, ensure that the WDI enters the high-Z state within the period of 1.4s after the last WDI falling edge.
7	7	1	nRESET	Active-Low Reset Output Pin. It delivers a 200ms (TYP) low pulse when activated. nRESET will remain low if V_{CC} is below the reset threshold or nMR is logic low. It goes (or remains) low for 200ms after any of the following events: V_{CC} rises above the reset threshold or the nMR input goes from low to high.
8	8	2	nWDO	Watchdog Output Pin. If WDI can not reach a rising edge or a falling edge in 1.6s, the watchdog timer will timeout. Meanwhile, nWDO is pulled low and remains low until the watchdog timer is cleared. nWDO goes low when V_{CC} is below the reset threshold. nWDO is different from nRESET in that it does not have a minimum pulse width. As long as V_{CC} is higher than the reset threshold, nWDO will immediately go high.
Exposed Pad	—	—	—	The exposed pad can be left floating.

8-Pin Microprocessor Supervisory Circuit with Watchdog Timer and Manual Reset

SGM706B

ELECTRICAL CHARACTERISTICS

($T_A = +25^\circ\text{C}$, $V_{CC} = 4.72\text{V}$ to 5.5V for SGM706B-L; $V_{CC} = 4.47\text{V}$ to 5.5V for SGM706B-M; $V_{CC} = 4.08\text{V}$ to 5.5V for SGM706B-J; $V_{CC} = 3.15\text{V}$ to 5.5V for SGM706B-T; $V_{CC} = 2.99\text{V}$ to 5.5V for SGM706B-S; $V_{CC} = 2.69\text{V}$ to 5.5V for SGM706B-R, Full = -40°C to $+125^\circ\text{C}$, unless otherwise noted.)

PARAMETER	CONDITIONS	TEMP	MIN	TYP	MAX	UNITS	
Operating Voltage Range (V_{CC})		Full	1.0		5.5	V	
Supply Current (I_{SUPPLY})	$V_{CC} = 3.6\text{V}$	Full		0.6	1.2	μA	
	$V_{CC} = 5.5\text{V}$	Full		0.8	1.5	μA	
nRESET Threshold (V_{nRST})	SGM706B-L	$+25^\circ\text{C}$	4.55	4.63	4.70	V	
		Full	4.52	4.63	4.72		
	SGM706B-M	$+25^\circ\text{C}$	4.30	4.38	4.45		
		Full	4.28	4.38	4.47		
	SGM706B-J	$+25^\circ\text{C}$	3.93	4.0	4.07		
		Full	3.92	4.0	4.08		
	SGM706B-T	$+25^\circ\text{C}$	3.03	3.08	3.14		
		Full	3.02	3.08	3.15		
	SGM706B-S	$+25^\circ\text{C}$	2.88	2.93	2.98		
		Full	2.87	2.93	2.99		
	SGM706B-R	$+25^\circ\text{C}$	2.58	2.63	2.68		
		Full	2.57	2.63	2.69		
nRESET Threshold Hysteresis	SGM706B-L	$+25^\circ\text{C}$		20		mV	
	SGM706B-M	$+25^\circ\text{C}$		19			
	SGM706B-J	$+25^\circ\text{C}$		17			
	SGM706B-T	$+25^\circ\text{C}$		13			
	SGM706B-S	$+25^\circ\text{C}$		13			
	SGM706B-R	$+25^\circ\text{C}$		11			
nRESET Threshold Temperature Coefficient		Full		20		ppm/ $^\circ\text{C}$	
nRESET Pulse Width (t_{RS})		Full	140	200	290	ms	
nRESET Output Voltage	$I_{SOURCE} = 800\mu\text{A}$	Full	$0.7 \times V_{CC}$			V	
	$I_{SINK} = 3.2\text{mA}$	Full			0.4		
	$V_{CC} = 1\text{V}$, $I_{SINK} = 50\mu\text{A}$	Full			0.3		
Watchdog Timeout Period (t_{WD})		Full	1.1	1.6	2.4	s	
WDI Pulse Width (t_{WP})	$V_{IL} = 0\text{V}$, $V_{IH} = V_{CC}$	Full	90			ns	
WDI Input Threshold	Low	$V_{CC} = 5\text{V}$	Full		0.8	V	
	High	$V_{CC} = 5\text{V}$	Full	3.5			
	Low	$V_{nRST(MAX)} < V_{CC} < 3.6\text{V}$	Full		0.8		
	High	$V_{nRST(MAX)} < V_{CC} < 3.6\text{V}$	Full	$0.7 \times V_{CC}$			
WDI Input Current	$WDI = V_{CC}$	UTDFN-1.5x1.5-8L only	Full		0.01	1.2	μA
		Other packages	Full		0.01	1.0	
	$WDI = 0\text{V}$	Full	-1.0	-0.01			
nWDO Output Voltage	$I_{SOURCE} = 800\mu\text{A}$	Full	$0.7 \times V_{CC}$			V	
	$I_{SINK} = 1.2\text{mA}$	Full			0.2		

ELECTRICAL CHARACTERISTICS (continued)

($T_A = +25^\circ\text{C}$, $V_{CC} = 4.72\text{V}$ to 5.5V for SGM706B-L; $V_{CC} = 4.47\text{V}$ to 5.5V for SGM706B-M; $V_{CC} = 4.08\text{V}$ to 5.5V for SGM706B-J; $V_{CC} = 3.15\text{V}$ to 5.5V for SGM706B-T; $V_{CC} = 2.99\text{V}$ to 5.5V for SGM706B-S; $V_{CC} = 2.69\text{V}$ to 5.5V for SGM706B-R, Full = -40°C to $+125^\circ\text{C}$, unless otherwise noted.)

PARAMETER	CONDITIONS		TEMP	MIN	TYP	MAX	UNITS
nMR Pull-Up Current	nMR = 0V, $V_{CC} = 5\text{V}$		Full	100		300	μA
nMR Pulse Width (t_{MR})			Full	300			ns
nMR Input Threshold	Low		Full			0.8	V
	High		Full	2			
nMR to nRESET Out Delay (t_{MD})			Full			420	ns
PFI Input Threshold	$V_{CC} = 5\text{V}$	UTDFN-1.5×1.5-8L only	Full	1.20	1.25	1.30	V
		Other packages	Full	1.21	1.25	1.29	V
PFI Input Current			Full		0.2	50	nA
nPFO Output Voltage	$I_{SOURCE} = 800\mu\text{A}$		Full	$0.7 \times V_{CC}$			V
	$I_{SINK} = 3.2\text{mA}$		Full			0.3	

TYPICAL PERFORMANCE CHARACTERISTICS

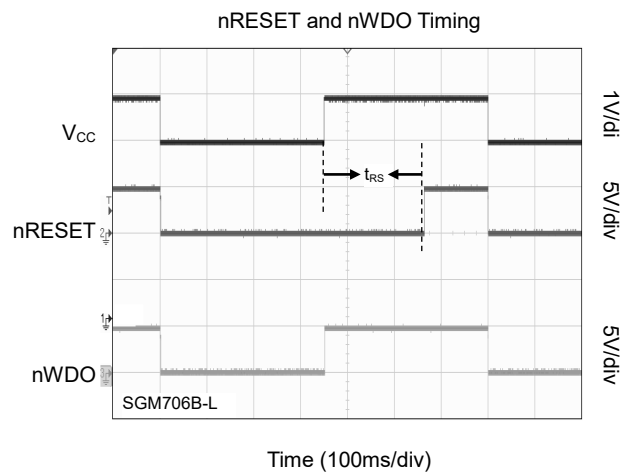
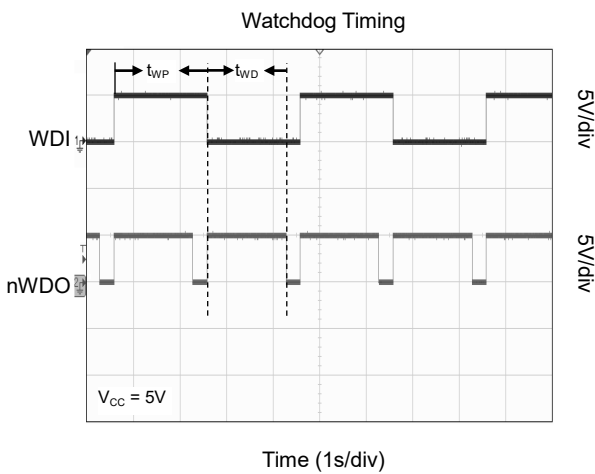
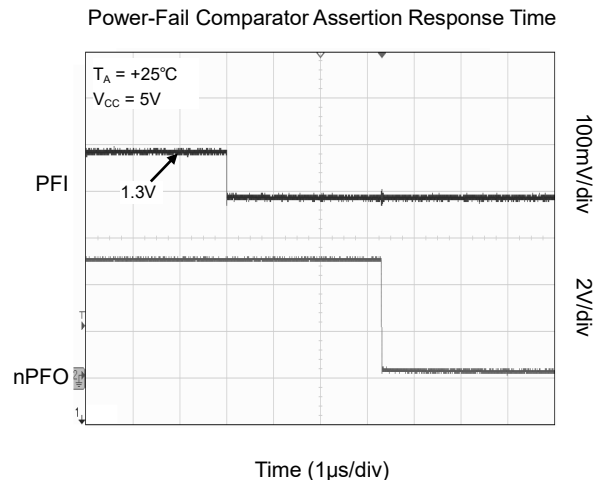
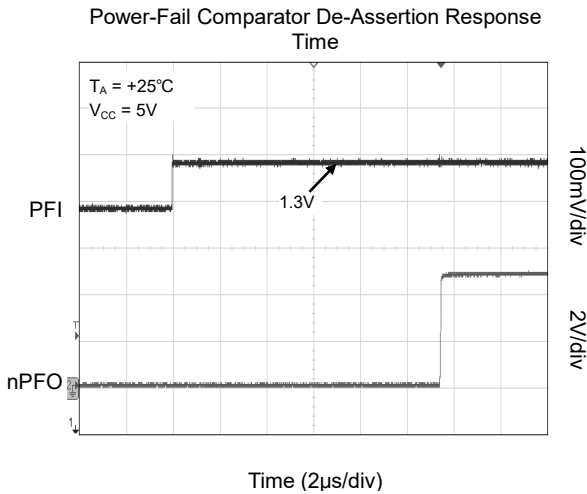
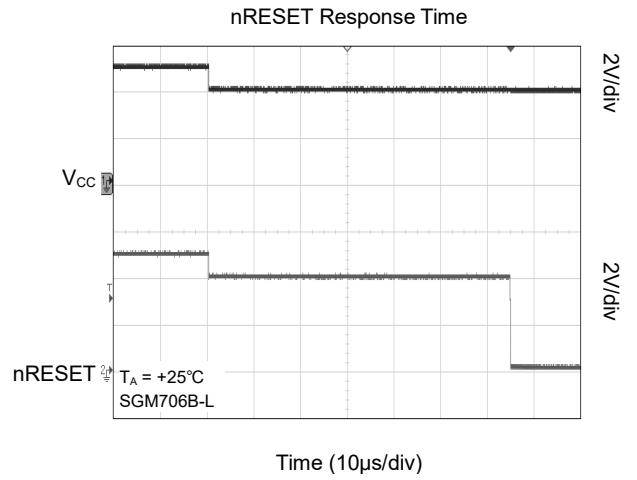
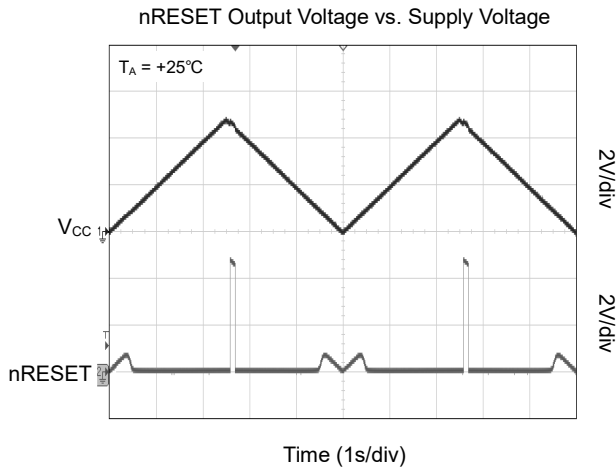

TYPICAL PERFORMANCE CHARACTERISTICS (continued)

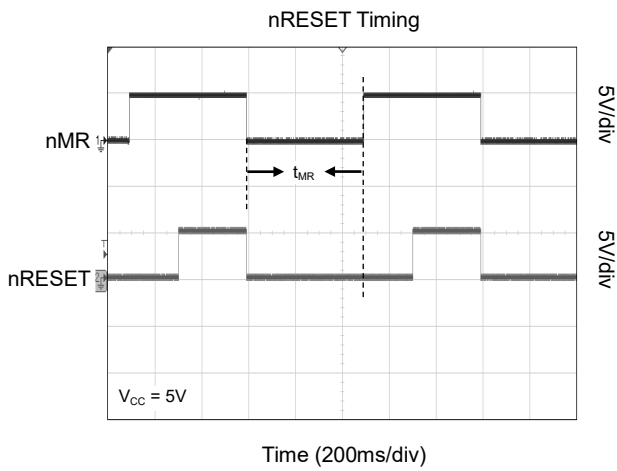

FUNCTIONAL BLOCK DIAGRAM

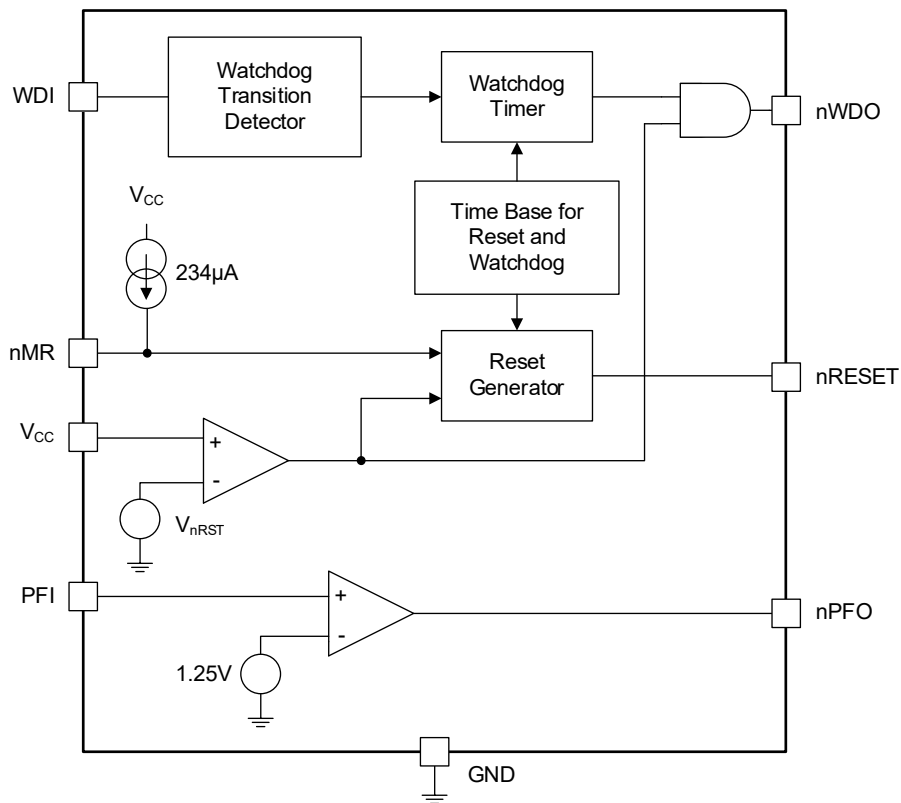

Figure 2. SGM706B Block Diagram

DETAILED DESCRIPTION

Precise Reset Threshold

When the supply voltage drops significantly for the power supply fault, the SGM706B can even operate normally, which greatly reduces the possibility of system failure. In addition, the internal reference voltage accuracy of the SGM706B is very high, which guarantees high reliability of the devices.

To ensure sufficient time for the power supply and microprocessor to stabilize after power-up, a 200ms (TYP) reset output will hold by the internal timer after V_{CC} exceeds the reset threshold voltage. Similarly, a 200ms (TYP) reset output will also exist after the power supply recover from brownout or interruption that allows the power supply and microprocessor to have enough time to reach a steady state.

The SGM706B has an active-low nRESET output. When V_{CC} is as low as 1V during power-down, the nRESET will keep output a low level. This not only keeps the microprocessor shutdown when the supply voltage falls, but also prevents the microprocessor from occurring false actions when it powers up.

Watchdog

A watchdog timer is integrated in SGM706B. It must be periodically triggered by a rising edge or a falling edge of WDI. If the WDI cannot be triggered during the timeout period (1.6s, TYP) and WDI is not three-stated, the internal watchdog timer expires and nWDO goes low.

The internal watchdog timer is cleared while a reset is asserted or WDI is three-stated or WDI is fed on time within the timeout period.

To disable the watchdog function, leave the WDI pin open. If WDI is driven by a 3-state buffer, set it to the Hi-Z state. In this case the buffer leakage current should not exceed 10 μ A. The maximum capacitance seen on the WDI pin should be less than 200pF to assure that watchdog remains disabled.

Manual Reset (nMR)

The SGM706B provides a manual reset (nMR) function that allows users to reset the system manually. It is an active-low reset input with an internal pull-up resistor of 25k Ω . When the nMR is low, and for t_{RS} (200ms, TYP), after nMR returns high, the reset remains active. The nMR can be driven by a CMOS logic or by a reset switch shorting to GND. If not used, leave it open or connect it to the V_{CC} . When the device is far away from the reset switch or used in a noisy environment, a 0.1 μ F capacitor is recommended to connect between nMR and GND.

PFI, nPFO

For SGM706B, PFI (Power-Fail Input) and nPFO (Power-Fail Push-Pull Output) pins can be used for power-fail warning or monitoring a power supply of the other device, and do not affect nRESET pin.

The internal voltage reference (1.25V) is used for compare with PFI pin. Once the PFI voltage is lower than the negative-going input threshold voltage, the nPFO goes low. Once PFI voltage exceeds positive-going input threshold voltage, the output goes high. Connecting a resistor divider externally can monitor any voltages above 1.25V.

To ensure that the PFI leakage current can be ignored in comparison with the current through the resistor divider and to minimize the resistor power consumption, the sum of two resistors should be about 1M Ω . To ensure the accuracy of the detection voltage, the tolerance of the external resistor should be less than 1%. It is recommended to leave nPFO floating and connect PFI to V_{CC} pin if the PFI comparator is not used.

APPLICATION INFORMATION

nRESET Valid to V_{CC} = 0V

The nRESET of SGM706B stops sinking current and becomes open circuit if V_{CC} is below 1.0V. And if a high-impedance input is connected to nRESET, the input voltage will drift and be undetermined. To solve the problem, it is recommended to use a 100kΩ resistor between nRESET and GND.

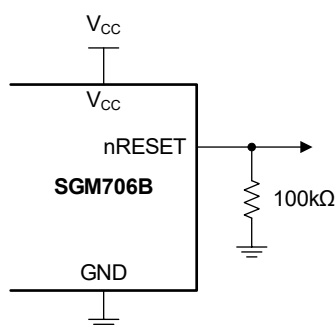

Figure 3. nRESET Valid to Ground Circuit

Monitoring Other Voltage Lines

Connect a voltage divider network to PFI and adjust the ratio appropriately. nPFO can be used to monitor another voltage line, which does not affect nRESET pin.

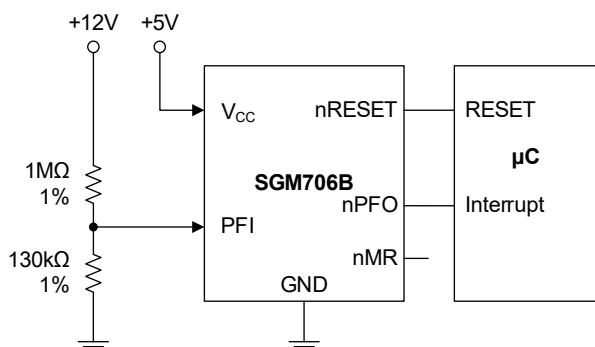

Figure 4. Power-Fail Voltage Monitoring

Connect a voltage divider network to PFI and connect nPFO to nMR can attain dual voltage lines monitoring simultaneously. It asserts nRESET in the conditions of 5V supply, V_{CC} falls below the reset threshold or the 12V supply falls approximately below 11V. Figure 5 shows the dual voltage lines monitoring of SGM706B configuration.

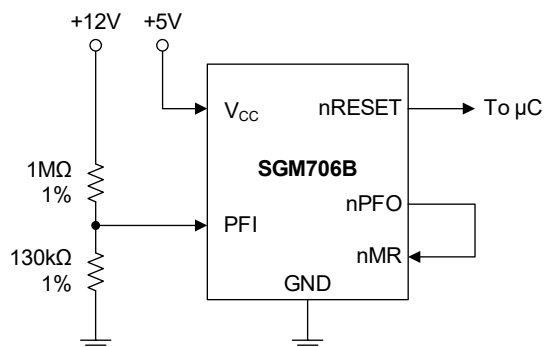

Figure 5. Dual Voltage Lines Monitoring

PFI can also be used to monitor a negative supply rail. The configuration is shown below. When the negative rail is lower than some negative voltage which makes V_{PFI} between 0V and 1.25V, a low nPFO will not drive the transistor to pull nMR low and nRESET will not be triggered. When the negative rail is degraded, which makes V_{PFI} be higher than 1.25V, a high nPFO drives the transistor to pull nMR low and trigger nRESET. And the accuracy of this circuit is not high, depending on the PFI threshold tolerance, V_{CC} line and the resistors.

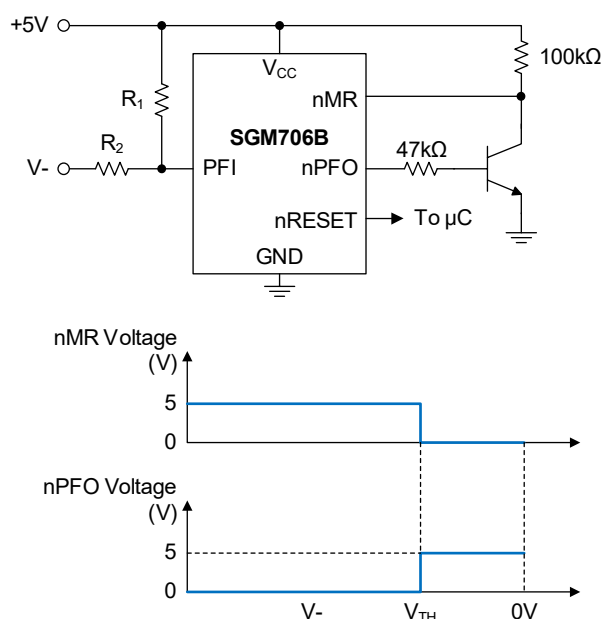

Figure 6. Negative Voltage Monitoring

The negative rail voltage can be calculated by Equation 1, and V_{TH} is always negative.

$$\frac{5 - 1.25}{R_1} = \frac{1.25 - V_{TH}}{R_2} \quad (1)$$

APPLICATION INFORMATION (continued)

The reset pin of some μC devices is bidirectional, such as the Motorola 68HC11 series. Connecting the SGM706B nRESET output to μC RESET output directly may cause race and hazard. For example, if nRESET is logic high and the RESET is logic low, connecting them directly may result in indeterminate logic levels, even damage the RESET pin of μC .

Therefore, a 4.7k Ω resistor is recommended to be connected between nRESET and the μC reset I/O as show in Figure 7. Besides, buffer the nRESET output to reset other system components.

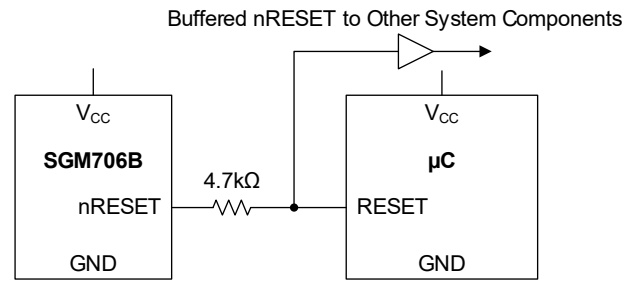

Figure 7. Interfacing to μC s with Bidirectional Reset I/O

REVISION HISTORY

NOTE: Page numbers for previous revisions may differ from page numbers in the current version.

	Page
MARCH 2026 – REV.B to REV.B.1	
Updated Application Information section.....	10
DECEMBER 2025 – REV.A.4 to REV.B	
Updated Absolute Maximum Ratings section.....	2
Updated Pin Description section.....	5
JUNE 2023 – REV.A.3 to REV.A.4	
Added Detailed Description section	10
APRIL 2023 – REV.A.2 to REV.A.3	
Updated General Description section.....	1
Updated Pin Description section	5
Added Detailed Description section	10
Updated Application Information section.....	11
JANUARY 2021 – REV.A.1 to REV.A.2	
Changed Electrical Characteristics section	6, 7
JUNE 2020 – REV.A to REV.A.1	
Added UTDFN-1.5×1.5-8L Package	All
Changes from Original to REV.A (DECEMBER 2018)	
Changed from product preview to production data.....	All

PACKAGE OUTLINE DIMENSIONS

UTDFN-1.5×1.5-8L

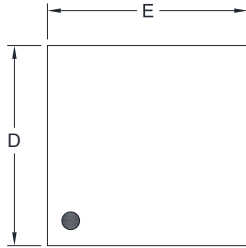

TOP VIEW

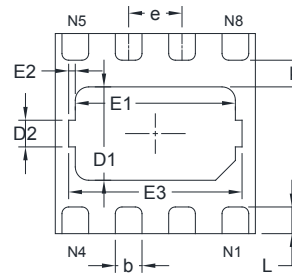

BOTTOM VIEW

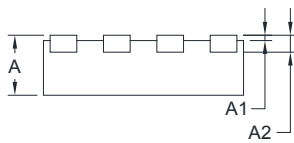

SIDE VIEW

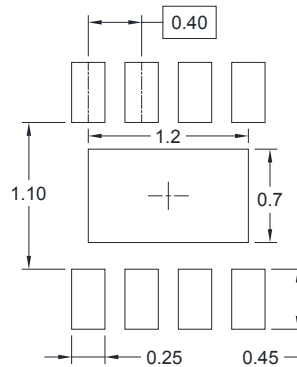

RECOMMENDED LAND PATTERN (Unit: mm)

Symbol	Dimensions In Millimeters		Dimensions In Inches	
	MIN	MAX	MIN	MAX
A	0.400	0.500	0.016	0.020
A1	0.000	0.050	0.000	0.002
A2	0.127 REF		0.005 REF	
D	1.450	1.550	0.057	0.061
D1	0.600	0.800	0.024	0.031
D2	0.200 REF		0.008 REF	
E	1.450	1.550	0.057	0.061
E1	1.100	1.300	0.043	0.051
E2	0.050 REF		0.002 REF	
E3	1.200	1.400	0.047	0.055
k	0.200 REF		0.008 REF	
b	0.150	0.250	0.006	0.010
e	0.400 BSC		0.016 BSC	
L	0.150	0.250	0.006	0.010

PACKAGE OUTLINE DIMENSIONS

SOIC-8

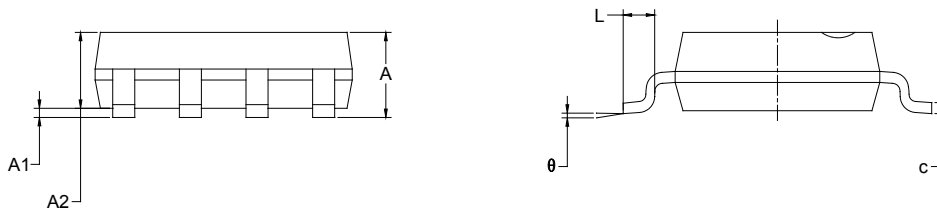
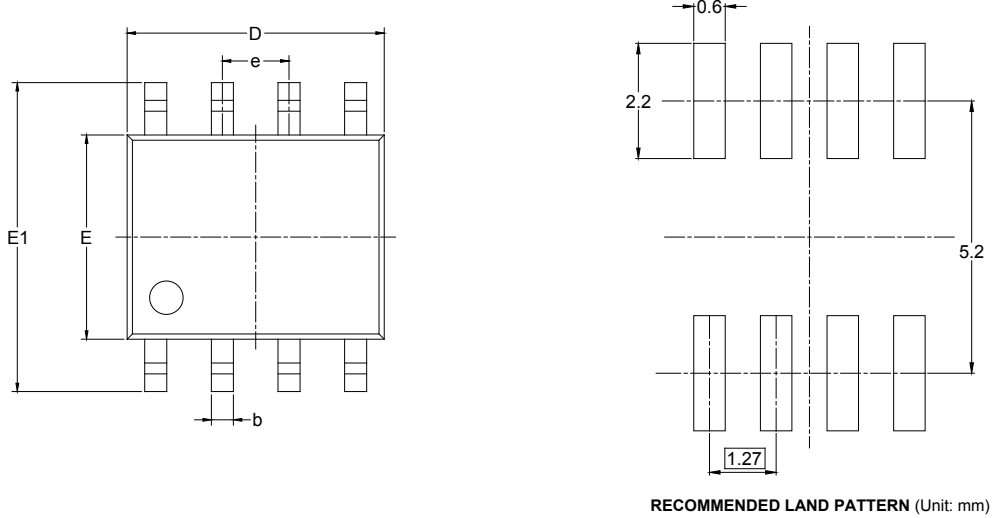

Symbol	Dimensions In Millimeters		Dimensions In Inches	
	MIN	MAX	MIN	MAX
A	1.350	1.750	0.053	0.069
A1	0.100	0.250	0.004	0.010
A2	1.350	1.550	0.053	0.061
b	0.330	0.510	0.013	0.020
c	0.170	0.250	0.006	0.010
D	4.700	5.100	0.185	0.200
E	3.800	4.000	0.150	0.157
E1	5.800	6.200	0.228	0.244
e	1.27 BSC		0.050 BSC	
L	0.400	1.270	0.016	0.050
θ	0°	8°	0°	8°

PACKAGE OUTLINE DIMENSIONS

MSOP-8

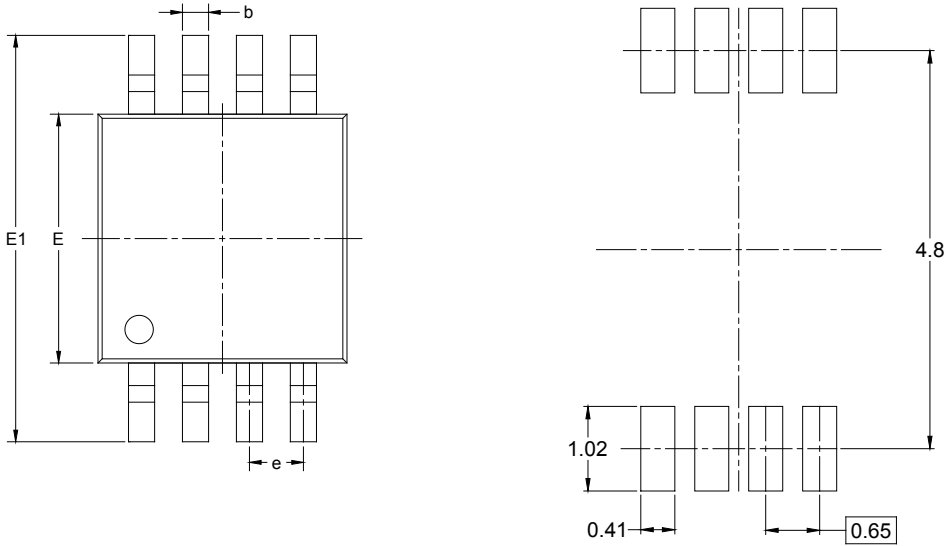

RECOMMENDED LAND PATTERN (Unit: mm)

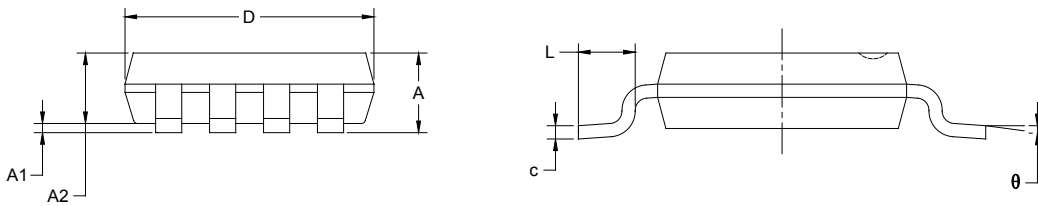

Symbol	Dimensions In Millimeters		Dimensions In Inches	
	MIN	MAX	MIN	MAX
A	0.820	1.100	0.032	0.043
A1	0.020	0.150	0.001	0.006
A2	0.750	0.950	0.030	0.037
b	0.250	0.380	0.010	0.015
c	0.090	0.230	0.004	0.009
D	2.900	3.100	0.114	0.122
E	2.900	3.100	0.114	0.122
E1	4.750	5.050	0.187	0.199
e	0.650 BSC		0.026 BSC	
L	0.400	0.800	0.016	0.031
θ	0°	6°	0°	6°

PACKAGE INFORMATION

TAPE AND REEL INFORMATION

REEL DIMENSIONS

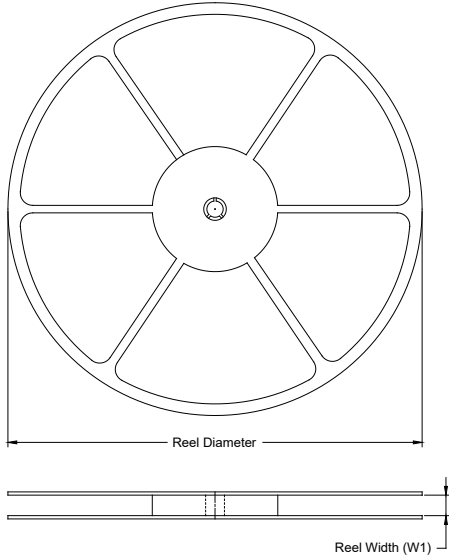

TAPE DIMENSIONS

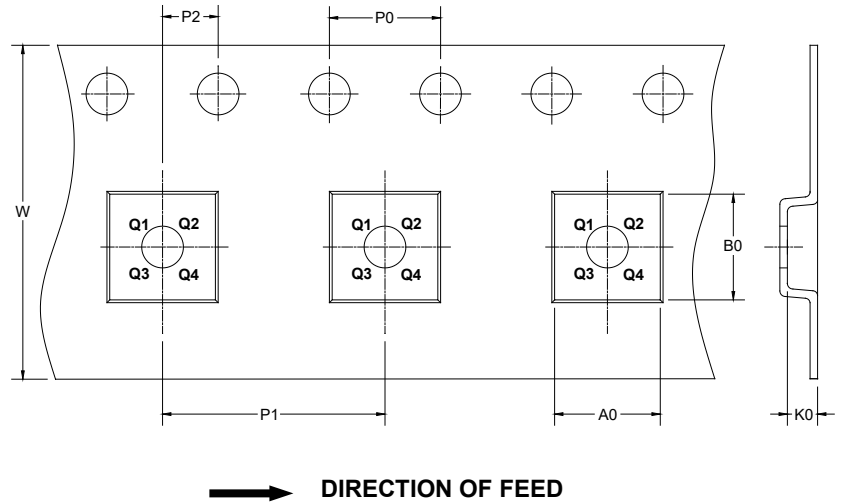

NOTE: The picture is only for reference. Please make the object as the standard.

KEY PARAMETER LIST OF TAPE AND REEL

Package Type	Reel Diameter	Reel Width W1 (mm)	A0 (mm)	B0 (mm)	K0 (mm)	P0 (mm)	P1 (mm)	P2 (mm)	W (mm)	Pin1 Quadrant
UTDFN-1.5×1.5-8L	7"	9.0	1.70	1.70	0.75	4.0	4.0	2.0	8.0	Q1
SOIC-8	13"	12.4	6.40	5.40	2.10	4.0	8.0	2.0	12.0	Q1
MSOP-8	13"	12.4	5.20	3.30	1.50	4.0	8.0	2.0	12.0	Q1

DD0001

PACKAGE INFORMATION

CARTON BOX DIMENSIONS

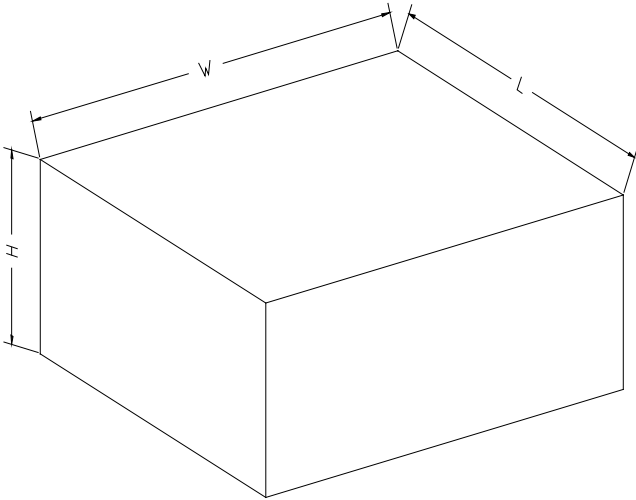

NOTE: The picture is only for reference. Please make the object as the standard.

KEY PARAMETER LIST OF CARTON BOX

Reel Type	Length (mm)	Width (mm)	Height (mm)	Pizza/Carton
7" (Option)	368	227	224	8
7"	442	410	224	18
13"	386	280	370	5

DD0002