



SGMGB04340 40V, WLCSP Package, GaN E-Mode Power Transistor

FEATURES

- Bidirectional Blocking Capability
- GaN-on-Silicon E-Mode HEMT Technology
- Ultra-Low On-Resistance
- RoHS Compliant and Halogen Free

APPLICATIONS

High-side Load Switch
OVP Protection in Smartphone USB Port
Switching Circuits in Multiple Power Supply Systems

ABSOLUTE MAXIMUM RATINGS

PARAMETER	SYMBOL	VALUE	UNITS
Drain-to-Source Voltage	V_{DS}	40	V
Source-to-Drain Voltage	V_{SD}	40	V
Drain-to-Gate Voltage	V_{DG}	40	V
Source-to-Gate Voltage	V_{SG}	40	V
Gate-to-Drain Voltage	V_{GD}	6	V
Gate-to-Source Voltage	V_{GS}	6	V
Drain Current	I_D	20	A
Drain Current (Pulse) ⁽¹⁾	I_{DM}	100	A
Total Dissipation	P_D	13	W
Junction Temperature	T_J	-40 to +125	°C
Storage Temperature Range	T_{STG}	-40 to +150	°C

Stresses beyond those listed in Absolute Maximum Ratings may cause permanent damage to the device. Exposure to absolute maximum rating conditions for extended periods may affect reliability.

NOTE: 1. $t_{PULSE} = 300\mu s$.

PRODUCT SUMMARY

$R_{DS(on)}$ & $R_{SD(on)}$ (TYP) $V_{GS} = 5V$	$R_{DS(on)}$ & $R_{SD(on)}$ (MAX) $V_{GS} = 5V$	I_D & I_S (MAX) $T_C = +25^\circ C$
4m Ω	4.8m Ω	20A

PIN CONFIGURATION

(TOP VIEW)

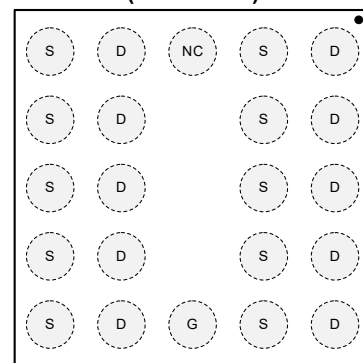

WLCSP-2.1x2.1-22B

EQUIVALENT CIRCUIT

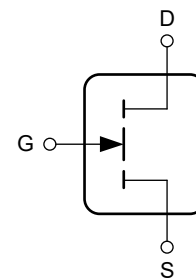

PACKAGE/ORDERING INFORMATION

MODEL	PACKAGE DESCRIPTION	SPECIFIED TEMPERATURE RANGE	ORDERING NUMBER	PACKAGE MARKING	PACKING OPTION
SGMGB04340	WLCSP-2.1x2.1-22B	-40°C to +150°C	SGMGB04340TG/TR	04340 XXXXX XX#XX	Tape and Reel, 2500

MARKING INFORMATION

NOTE: XXXXX = Date Code, Trace Code and Vendor Code. XX#XX = Coordinate Information and Wafer ID Number.

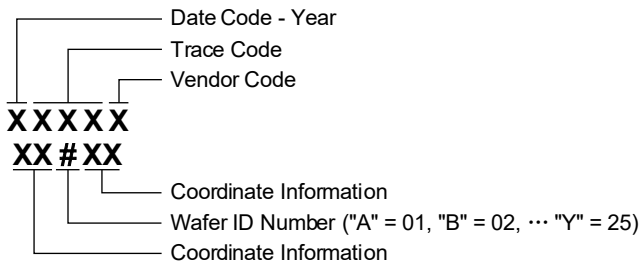

Green (RoHS & HSF): SG Micro Corp defines "Green" to mean Pb-Free (RoHS compatible) and free of halogen substances. If you have additional comments or questions, please contact your SGMICRO representative directly.

DISCLAIMER

SG Micro Corp reserves the right to make any change in circuit design, or specifications without prior notice.

THERMAL RESISTANCE

PARAMETER	SYMBOL	TYP	UNITS
Junction-to-Ambient Thermal Resistance ⁽¹⁾	R _{θJA}	59.3	°C/W
Junction-to-Case Thermal Resistance	R _{θJC_TOP}	12.6	°C/W
	R _{θJC_BOTTOM}	7.6	

NOTE: 1. R_{θJA} is determined with the device mounted on one square inch of copper pad, single layer 2oz copper on FR4 board.

ELECTRICAL CHARACTERISTICS

(T_J = +25°C, unless otherwise noted.)

PARAMETER	SYMBOL	CONDITIONS		MIN	TYP	MAX	UNITS
Static Characteristics							
Drain-to-Source Breakdown Voltage	V _{BR_DSS}	V _G = V _S = 0V, I _{DS} = 500μA		40			V
Source-to-Drain Breakdown Voltage	V _{BR_SDS}	V _G = V _D = 0V, I _{SD} = 500μA		40			V
Zero Gate Voltage Drain Current	I _{DSS}	V _G = V _S = 0V, V _D = 40V				20	μA
Zero Gate Voltage Source Current	I _{SDS}	V _G = V _D = 0V, V _S = 40V				20	μA
Gate-to-Drain Leakage Current	I _{GDS}	T _J = +25°C, V _D = V _S = 0V	V _G = 5V		0.4	3	μA
			V _G = -5V	-30			
			V _G = 6V		4	30	
			V _G = -6V	-40			
		T _J = +85°C, V _D = V _S = 0V	V _G = 5V		0.5	3	
			V _G = -5V	-30			
			V _G = 6V		5	30	
			V _G = -6V	-40			
Gate-to-Source Leakage Current	I _{GSS}	T _J = +25°C, V _D = V _S = 0V	V _G = 5V		0.4	3	μA
			V _G = -5V	-30			
			V _G = 6V		4	30	
			V _G = -6V	-40			
		T _J = +85°C, V _D = V _S = 0V	V _G = 5V		0.5	3	
			V _G = -5V	-30			
			V _G = 6V		5	30	
			V _G = -6V	-40			
Gate-to-Drain Threshold Voltage	V _{GD_TH}	V _G = V _S , V _D = 0V, I _{SD} = 1mA		0.8		2.4	V
Gate-to-Source Threshold Voltage	V _{GS_TH}	V _G = V _D , V _S = 0V, I _{DS} = 1mA		0.8		2.4	V
Drain-to-Source On-State Resistance	R _{DSON}	V _{GS} = 5V, V _S = 0V, I _{DS} = 10A			4	4.8	mΩ
Source-to-Drain On-State Resistance	R _{SDON}	V _{GD} = 5V, V _D = 0V, I _{SD} = 10A			4	4.8	mΩ
Gate Resistance	R _G	f = 1MHz			4.1		Ω
Dynamic Characteristics							
Input Capacitance	C _{ISS}				892		pF
Output Capacitance	C _{OSS}	V _G = 0V, V _D = 20V, or V _G = 0V, V _S = 20V			384		
Reverse Transfer Capacitance	C _{RSS}				226		
Total Gate Charge	Q _G	V _G = 5V	V _D = 20V, I _D = 10A		15.9		nC
			V _S = 20V, I _S = 10A		15.9		
Gate-to-Drain Charge	Q _{GD}	V _D = 0V, V _S = 20V, I _{SD} = 10A			1.9		
		V _D = 20V, V _S = 0V, I _{DS} = 10A			8.6		
Gate-to-Source Charge	Q _{GS}	V _D = 20V, V _S = 0V, I _{DS} = 10A			1.9		
		V _D = 0V, V _S = 20V, I _{SD} = 10A			8.6		
Output Charge	Q _{OSS}	V _G = 0V	V _D = 20V		12.2		
			V _S = 20V		12.2		

TYPICAL PERFORMANCE CHARACTERISTICS

Figure 1 Typical Output Characteristics ($T_J = 25\text{ }^\circ\text{C}$)

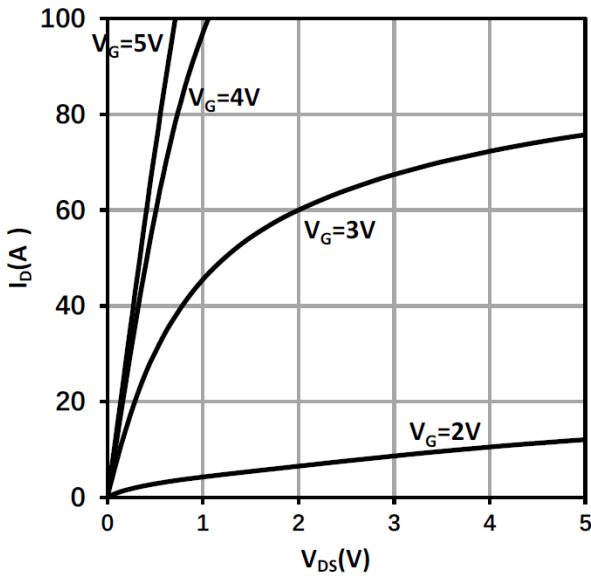

Figure 2 Typical Output Characteristics ($T_J = 125\text{ }^\circ\text{C}$)

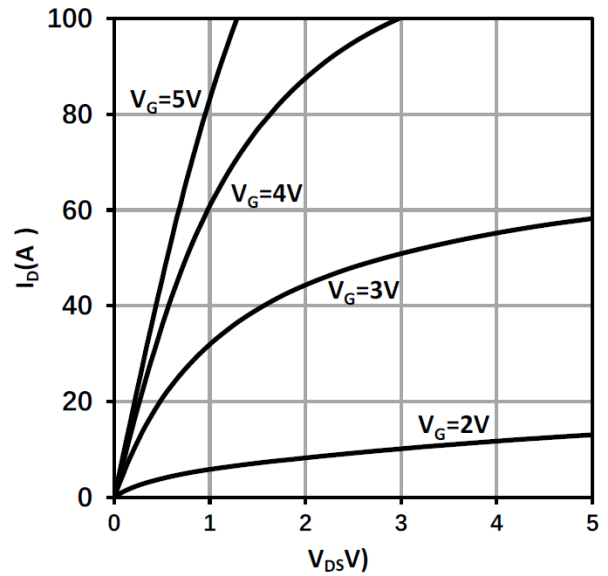

Figure 3 Typical Drain On-state Resistance

($T_J = 25\text{ }^\circ\text{C}$)

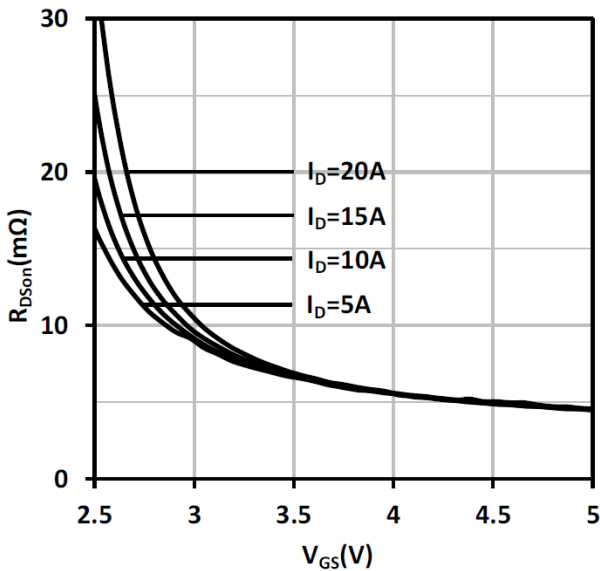
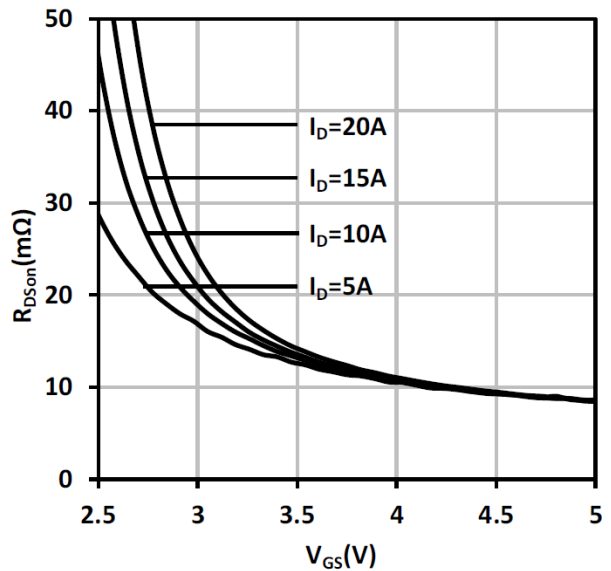

Figure 4 Typical Drain On-state Resistance

($T_J = 125\text{ }^\circ\text{C}$)



TYPICAL PERFORMANCE CHARACTERISTICS (continued)

Figure 5 Typical On Resistance vs. Temperature

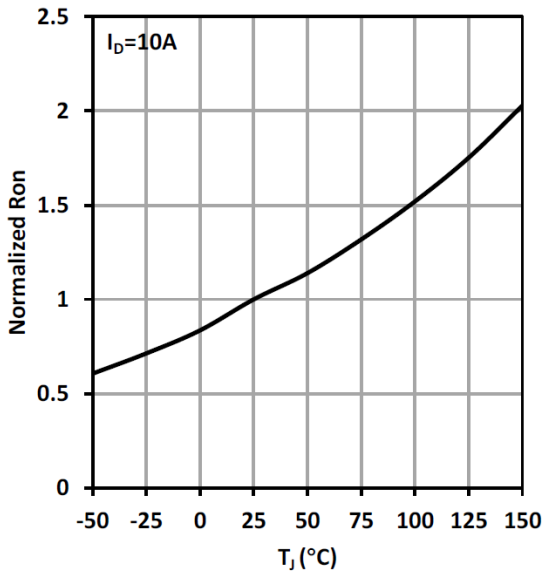

Figure 6 Typical Transfer Characteristics

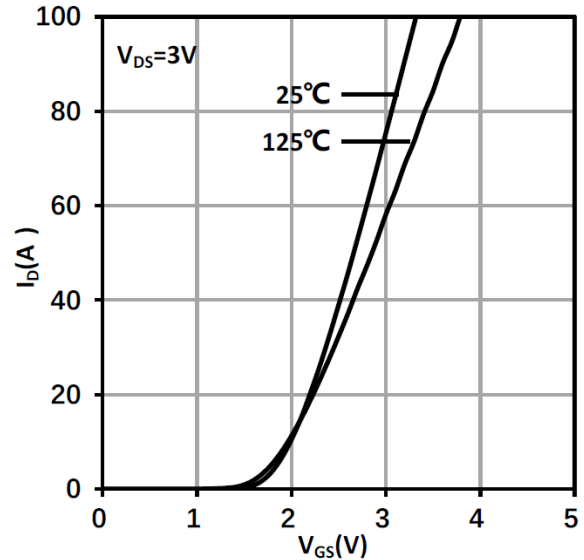

Figure 7 Typ. Reverse Drain-Source Characteristics ($V_{GS} \leq 0V$, $T_J = 25^\circ C$)

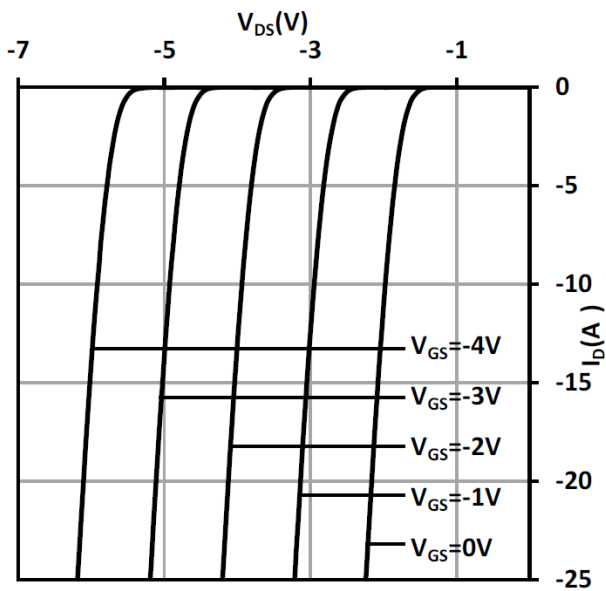
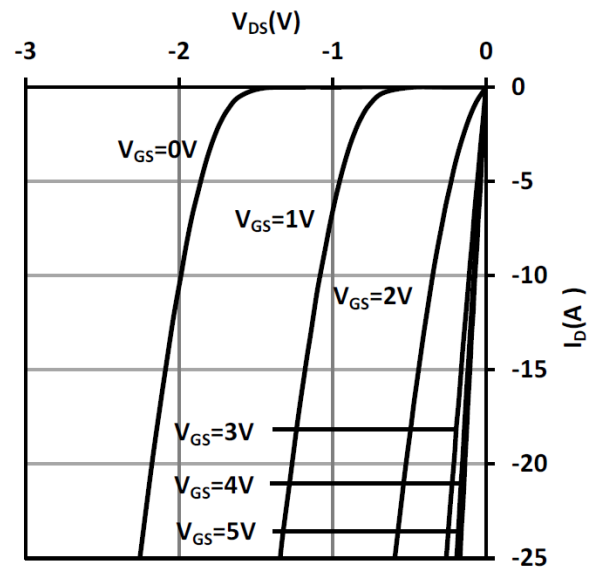

Figure 8 Typ. Reverse Drain-Source Characteristics ($V_{GS} \geq 0V$, $T_J = 25^\circ C$)



TYPICAL PERFORMANCE CHARACTERISTICS (continued)

Figure 9 Typ. Reverse Drain-Source Characteristics
($V_{GS} \leq 0V$, $T_J = 125^\circ C$)

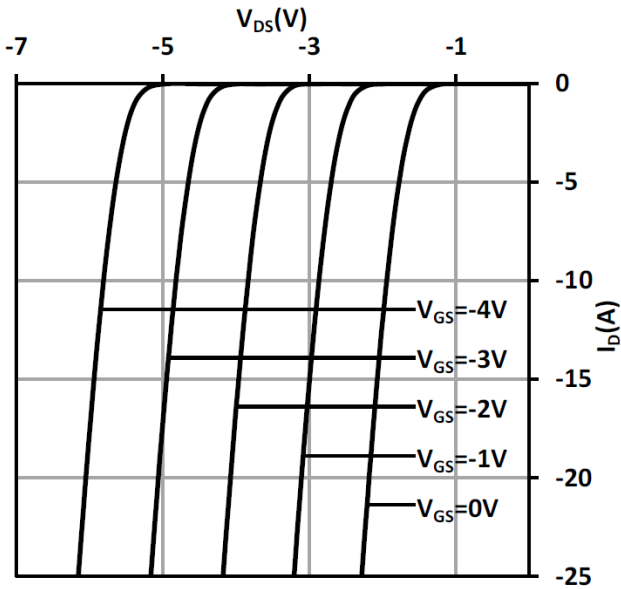

Figure 10 Typ. Reverse Drain-Source Characteristics
($V_{GS} \geq 0V$, $T_J = 125^\circ C$)

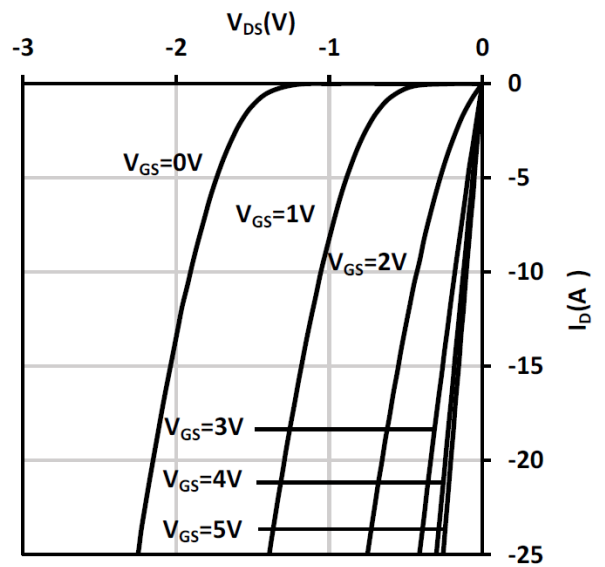

Figure 11 Typical Capacitances Characteristics

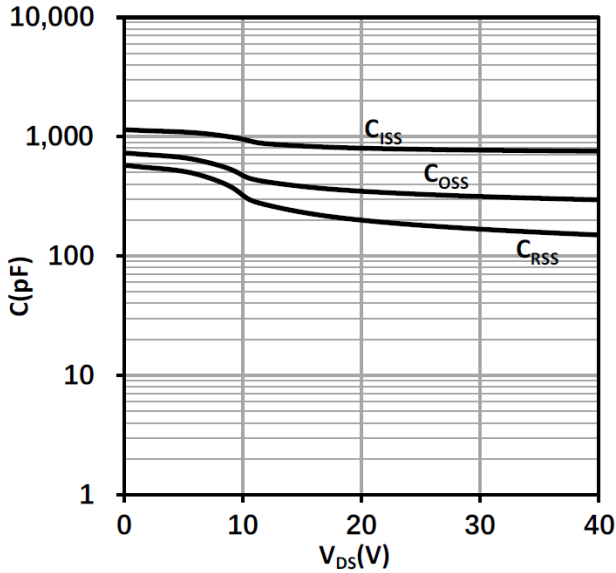
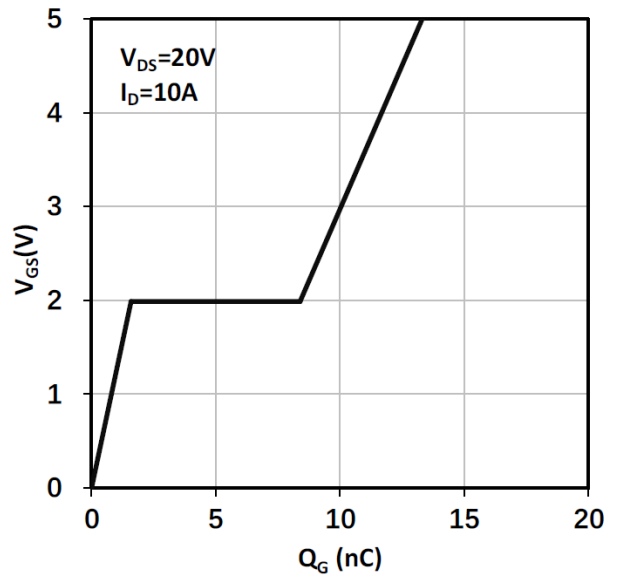

Figure 12 Typical Gate Charge



TYPICAL PERFORMANCE CHARACTERISTICS (continued)

Figure 13 Normalized Threshold Voltage vs. Temp.

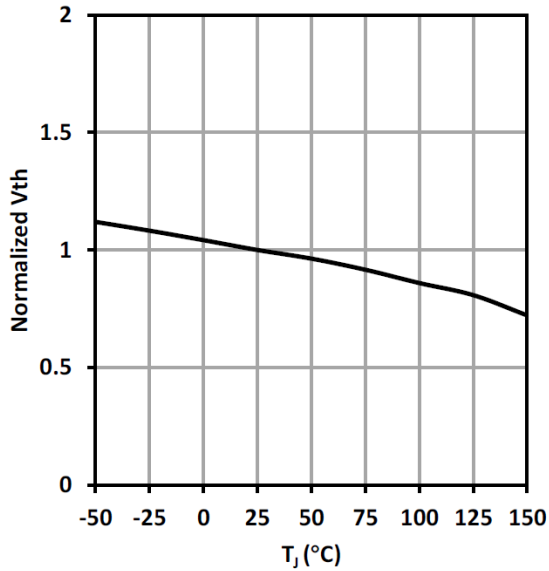

Figure 14 Output Charge

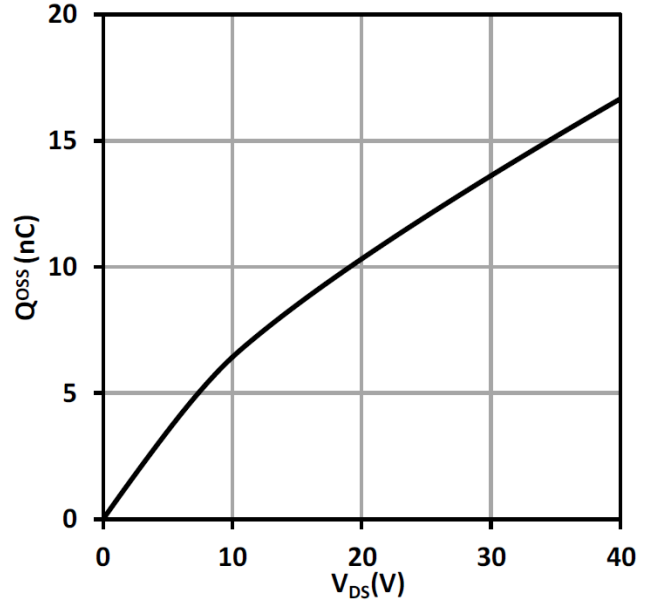

Figure 15 Output Capacitance Stored Energy

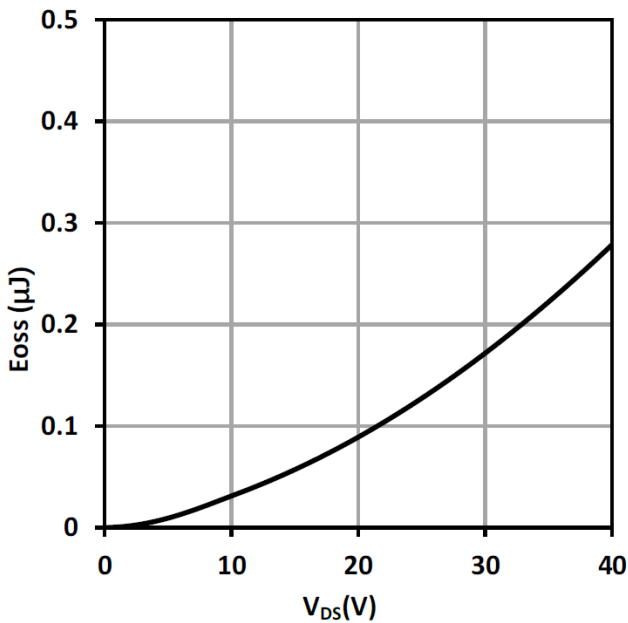
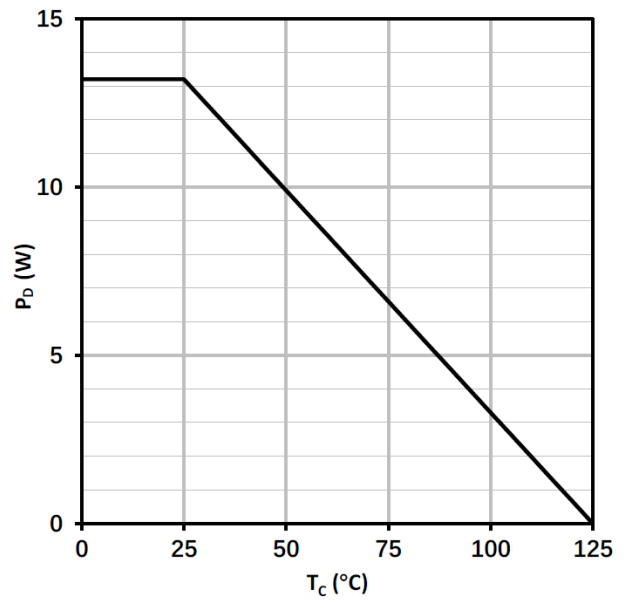

Figure 16 Power Dissipation



TYPICAL PERFORMANCE CHARACTERISTICS (continued)

Figure 17 Safe Operating Area

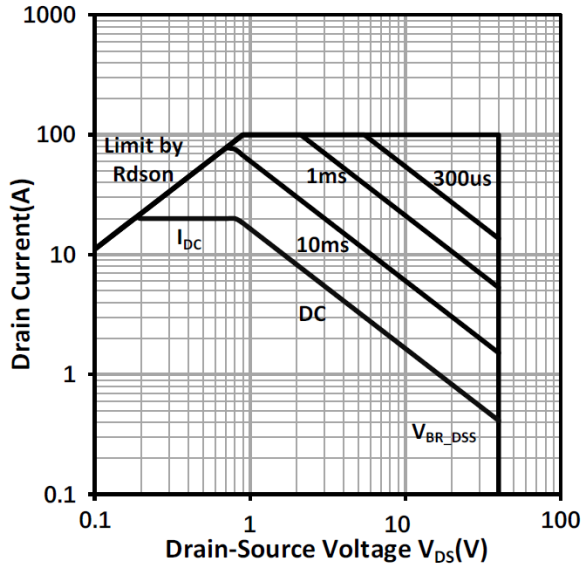
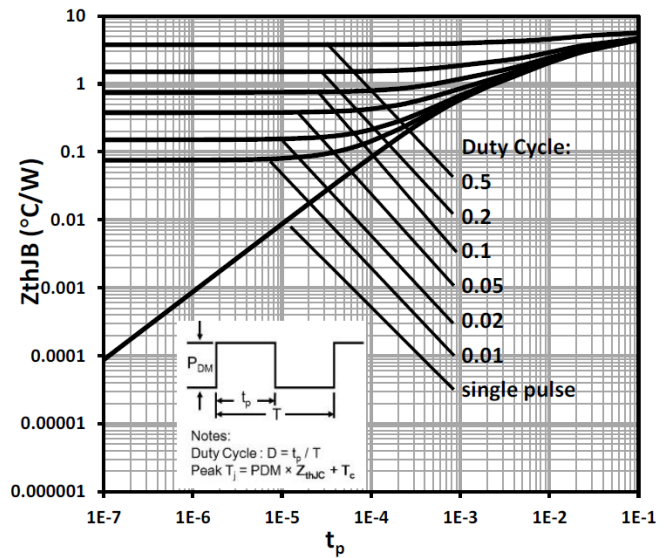

Figure 18 Max. Transient Thermal Impedance



REVISION HISTORY

NOTE: Page numbers for previous revisions may differ from page numbers in the current version.

Changes from Original to REV.A (JUNE 2026)	Page
Changed from product preview to production data.....	All

PACKAGE INFORMATION

PACKAGE OUTLINE DIMENSIONS

WLCSP-2.1×2.1-22B

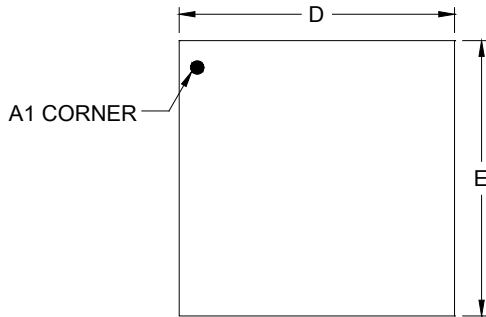

TOP VIEW

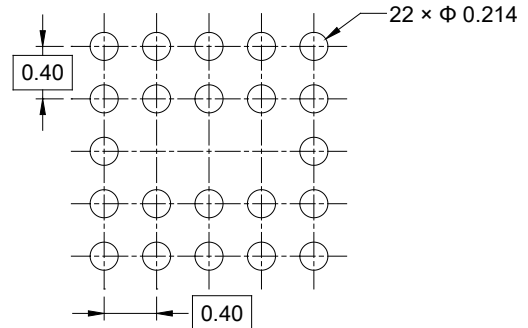

RECOMMENDED LAND PATTERN (Unit: mm)

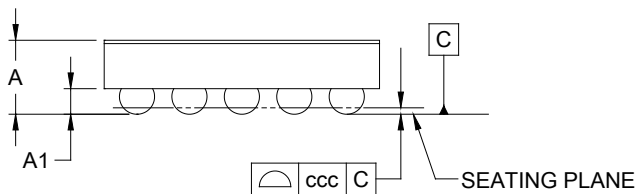

SIDE VIEW

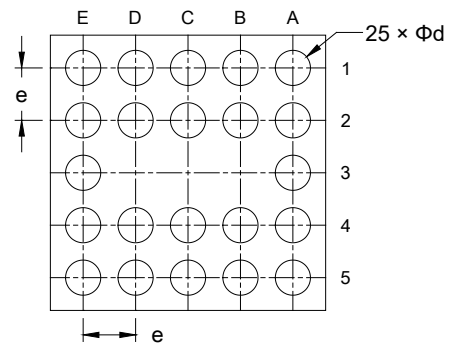

BOTTOM VIEW

Symbol	Dimensions In Millimeters		
	MIN	NOM	MAX
A	-	-	0.611
A1	0.165	-	0.225
D	2.070	-	2.130
E	2.070	-	2.130
d	0.238	-	0.298
e	0.400 BSC		
ccc	0.050		

NOTE: This drawing is subject to change without notice.

PACKAGE INFORMATION

TAPE AND REEL INFORMATION

REEL DIMENSIONS

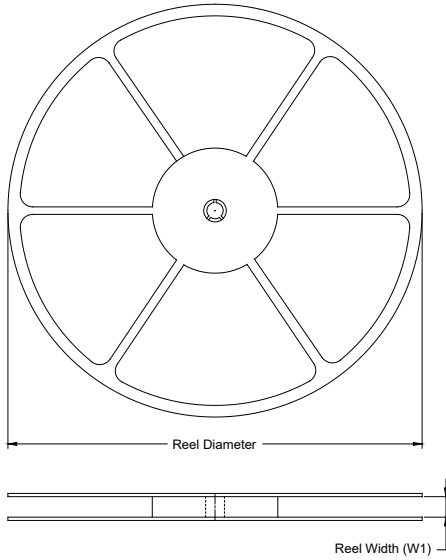

TAPE DIMENSIONS

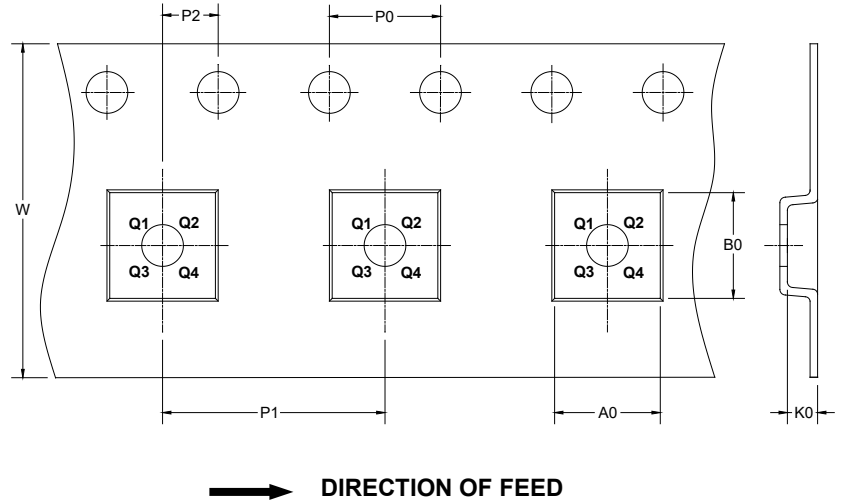

NOTE: The picture is only for reference. Please make the object as the standard.

KEY PARAMETER LIST OF TAPE AND REEL

Package Type	Reel Diameter	Reel Width W1 (mm)	A0 (mm)	B0 (mm)	K0 (mm)	P0 (mm)	P1 (mm)	P2 (mm)	W (mm)	Pin1 Quadrant
WLCSP-2.1×2.1-22B	7"	9.0	2.25	2.25	0.80	4.0	4.0	2.0	8.0	Q2

DD0001

PACKAGE INFORMATION

CARTON BOX DIMENSIONS

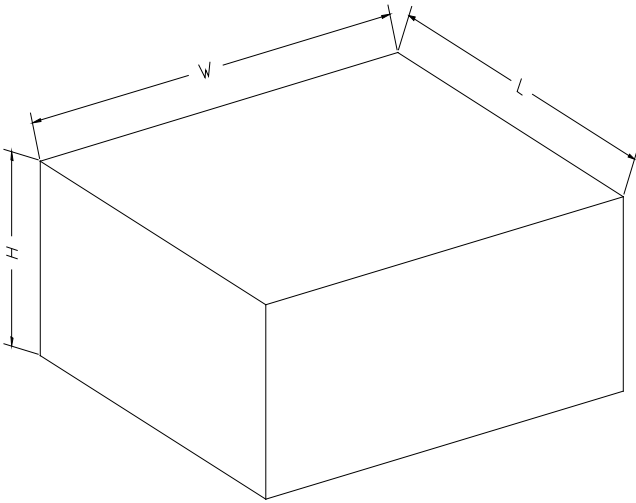

NOTE: The picture is only for reference. Please make the object as the standard.

KEY PARAMETER LIST OF CARTON BOX

Reel Type	Length (mm)	Width (mm)	Height (mm)	Pizza/Carton
7" (Option)	368	227	224	8
7"	442	410	224	18

D00002