

GENERAL DESCRIPTION

The SGM9100 consists of four resistors that have great matching characteristics over the whole temperature range. The device can be used in the differential amplifier due to the specified resistor matching network. This improved matching feature ensures that the CMRR performance is twice better than that of resistors that are matched separately.

The SGM9100 allows independent access and biasing of all four resistors, so it is a flexible and convenient option for all the applications, which can take advantage of these matched resistors.

The quad matched resistor network offers accurate ratio stability, making the SGM9100 suitable for the applications requiring high precision, such as differential amplifiers, bridge circuits and voltage references.

The SGM9100 is available in a Green MSOP-8 (Exposed Pad) package. It is rated over the -40°C to +85°C operating temperature range.

FEATURES

- **Excellent Matching: $\pm 0.01\%$ (MAX) Matching**
- **Resistor Matching Ratio Temperature Drift: $\pm 0.24\text{ppm}/^\circ\text{C}$ (TYP)**
- **Absolute Resistor Value Temperature Drift: $5\text{ppm}/^\circ\text{C}$ (TYP)**
- **Resistor Matching Ratio Long-Term Drift: 15ppm at 2000h**
- **Operating Voltage Range: $\pm 75\text{V}$**
- **Absolute Maximum Voltage Range: $\pm 80\text{V}$**
- **-40°C to +85°C Operating Temperature Range**
- **Available in a Green MSOP-8 (Exposed Pad) Package**

APPLICATIONS

- Precision Differential Amplifier
- Precision Resistor Divider for Voltage Reference
- Precision Current and Voltage Summing/Subtracting

TYPICAL APPLICATION

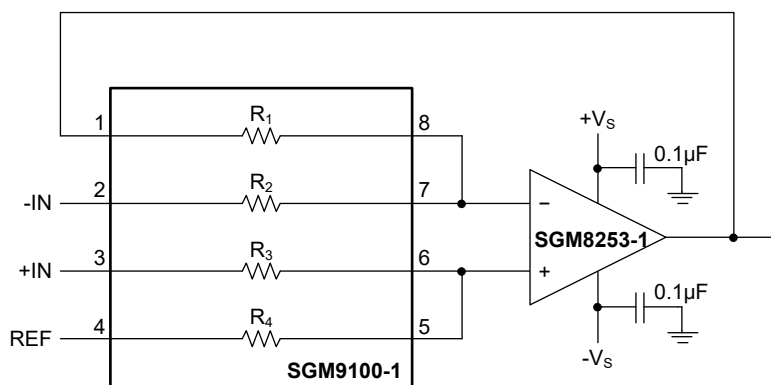

Figure 1. Typical Application Circuit

PACKAGE/ORDERING INFORMATION

MODEL	PACKAGE DESCRIPTION	SPECIFIED TEMPERATURE RANGE	ORDERING NUMBER	PACKAGE MARKING	PACKING OPTION
SGM9100-1	MSOP-8 (Exposed Pad)	0°C to +70°C	SGM9100-1ZPMS8G/TR	SGM0GH ZPMS8 XXXXX	Tape and Reel, 4000
SGM9100-2	MSOP-8 (Exposed Pad)	0°C to +70°C	SGM9100-2ZPMS8G/TR	SGM0Y1 ZPMS8 XXXXX	Tape and Reel, 4000
SGM9100-3	MSOP-8 (Exposed Pad)	0°C to +70°C	SGM9100-3ZPMS8G/TR	SGM0Y2 ZPMS8 XXXXX	Tape and Reel, 4000
SGM9100-5	MSOP-8 (Exposed Pad)	0°C to +70°C	SGM9100-5ZPMS8G/TR	SGM0Y3 ZPMS8 XXXXX	Tape and Reel, 4000

MARKING INFORMATION

NOTE: XXXXX = Date Code, Trace Code and Vendor Code.

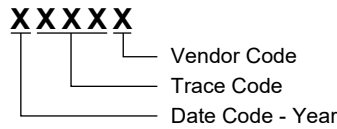

Green (RoHS & HSF): SG Micro Corp defines "Green" to mean Pb-Free (RoHS compatible) and free of halogen substances. If you have additional comments or questions, please contact your SGMICRO representative directly.

ABSOLUTE MAXIMUM RATINGS

- Total Voltage (between any pair of pins)⁽¹⁾ ±80V
- Power Dissipation (any resistor)⁽²⁾ 800mW
- Package Thermal Resistance
 - MSOP-8 (Exposed Pad), θ_{JA} 52°C/W
 - MSOP-8 (Exposed Pad), θ_{JB} 26.9°C/W
 - MSOP-8 (Exposed Pad), $\theta_{JC(TOP)}$ 63.3°C/W
 - MSOP-8 (Exposed Pad), $\theta_{JC(BOT)}$ 12.8°C/W
- Junction Temperature.....+150°C
- Storage Temperature Range..... -65°C to +150°C
- Lead Temperature (Soldering, 10s).....+260°C
- ESD Susceptibility⁽³⁾⁽⁴⁾
- HBM (SGM9100-1) ±1000V
- HBM (SGM9100-2/3/5)..... ±500V
- CDM ±1000V

NOTES:

1. Do not apply a voltage difference greater than the absolute maximum ratings between any two pins. This applies to any resistor, any pin relative to the package's exposed pad, and any pair of pins that are not connected.
2. When the ambient temperature is high, the maximum power dissipation must be lowered to prevent the junction temperature from exceeding the absolute maximum ratings.
3. For human body model (HBM), all pins comply with ANSI/ESDA/JEDEC JS-001 specifications.
4. For charged device model (CDM), all pins comply with ANSI/ESDA/JEDEC JS-002 specifications.

RECOMMENDED OPERATING CONDITIONS

- Operating Temperature Range..... -40°C to +85°C
- Specified Temperature Range0°C to +70°C

OVERSTRESS CAUTION

Stresses beyond those listed in Absolute Maximum Ratings may cause permanent damage to the device. Exposure to absolute maximum rating conditions for extended periods may affect reliability. Functional operation of the device at any conditions beyond those indicated in the Recommended Operating Conditions section is not implied.

ESD SENSITIVITY CAUTION

This integrated circuit can be damaged if ESD protections are not considered carefully. SGMICRO recommends that all integrated circuits be handled with appropriate precautions. Failure to observe proper handling and installation procedures can cause damage. ESD damage can range from subtle performance degradation to complete device failure. Precision integrated circuits may be more susceptible to damage because even small parametric changes could cause the device not to meet the published specifications.

DISCLAIMER

SG Micro Corp reserves the right to make any change in circuit design, or specifications without prior notice.

PIN CONFIGURATION

FUNCTIONAL BLOCK DIAGRAM

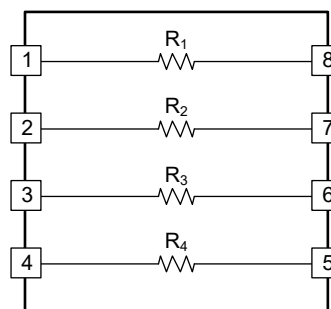
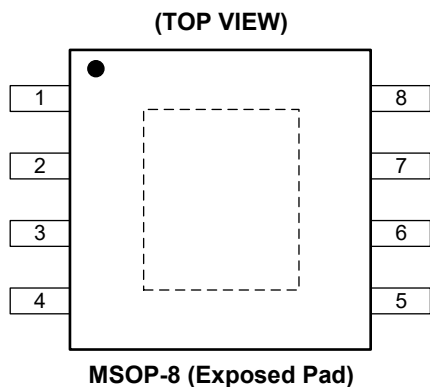

AVAILABLE OPTIONS

Part Number	R ₂ = R ₃	R ₁ = R ₄	Resistor Ratio
SGM9100-1	10kΩ	10kΩ	1:1
SGM9100-2	100kΩ	100kΩ	1:1
SGM9100-3	10kΩ	100kΩ	1:10
SGM9100-5	1MΩ	1MΩ	1:1

ELECTRICAL CHARACTERISTICS

(T_A = 0°C to +70°C, typical values are at T_A = +25°C, unless otherwise noted.)

PARAMETER	SYMBOL	CONDITIONS	MIN	TYP	MAX	UNITS
Resistor Matching Ratio (Any Resistor to Any Other Resistor)	ΔR/R	T _A = +25°C			±0.01	%
		T _A = 0°C to +70°C			±0.01	
Matching for CMRR ⁽¹⁾	(ΔR/R) _{CMRR}	T _A = 0°C to +70°C			±0.005	%
Resistor Matching Ratio Temperature Drift	(ΔR/R)/ΔT	T _A = 0°C to +70°C		±0.24	±1	ppm/°C
Resistor Voltage Coefficient		T _A = 0°C to +70°C		0.1		ppm/V
Excess Current Noise ⁽²⁾				< -55		dB
Absolute Resistor Tolerance	ΔR	0.01% matching, T _A = 0°C to +70°C			±7.5	%
Distributed Capacitance		Resistor to exposed pad		5		pF
		Resistor to resistor		2		
Absolute Resistor Value Temperature Drift	ΔR/ΔT	T _A = 0°C to +70°C		5	10	ppm/°C
Resistor Matching Ratio Long-Term Drift		T _A = +35°C, 2000h, 10mW		15		ppm
		T _A = +70°C, 1000h, 10mW		20		
Resistor Matching Ratio Moisture Resistance		T _A = +85°C, 85%R.H., 168h		4		ppm
Resistor Matching Ratio Thermal Shock/Hysteresis		T _A = -50°C to +150°C, 5 cycles		4		ppm
Resistor Matching Ratio IR Reflow		T _A = +25°C to +260°C, 3 cycles		4		ppm
Resistor Matching Ratio Accelerated Shelf Life		T _A = +150°C, 1000h		5		ppm
Harmonic Distortion		20V _{P-P} , 1kHz, differential amplifier		-120		dBc
Shelf Life		T _A = +25°C, unbiased, 1 year		4		ppm

NOTES:

1. When specific resistors are used in a differential configuration of R₁/R₂ and R₄/R₃ with the SGM9100, the error produced by it is quantified by (ΔR/R)_{CMRR} (Matching of CMRR), whose equation is as follows. The Typical Application Circuits section shows examples of differential amplifier and instrumentation amplifier.

$$(\Delta R / R)_{CMRR} = \frac{1}{2} \times \left(\frac{R_2}{R_1} - \frac{R_3}{R_4} \right) \times \left(\frac{R_1}{R_2} \right)$$

The effect of the resistors on CMRR can be calculated as follows.

$$CMRR = (\Delta R / R)_{CMRR} \times \left(\frac{4 \times \frac{R_2}{R_1}}{2 + \frac{R_2}{R_1} + \frac{R_3}{R_4}} \right)$$

When the resistor ratio is 1:1 for SGM9100 options, the effect of the resistors on CMRR can be approximated by: CMRR ≈ (ΔR/R)_{CMRR}.

2. This parameter is only applicable to the SGM9100-1 and SGM9100-2.

TYPICAL PERFORMANCE CHARACTERISTICS

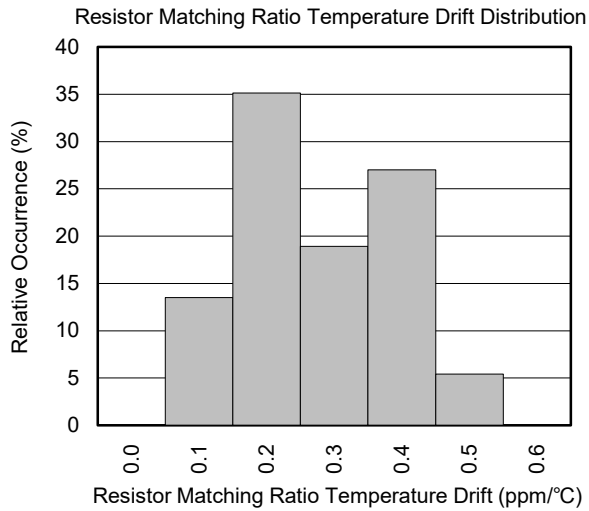
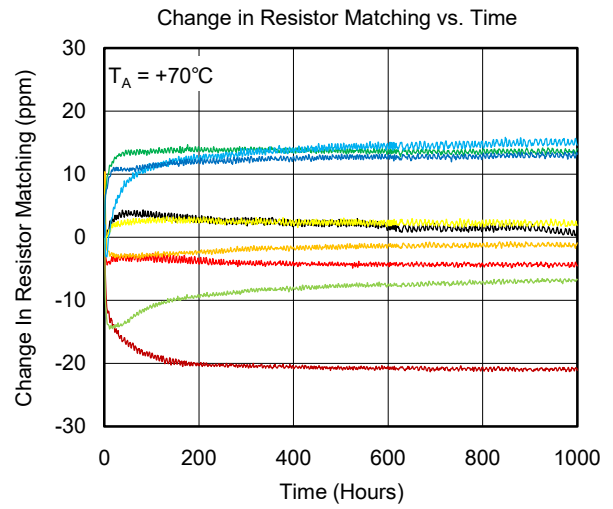
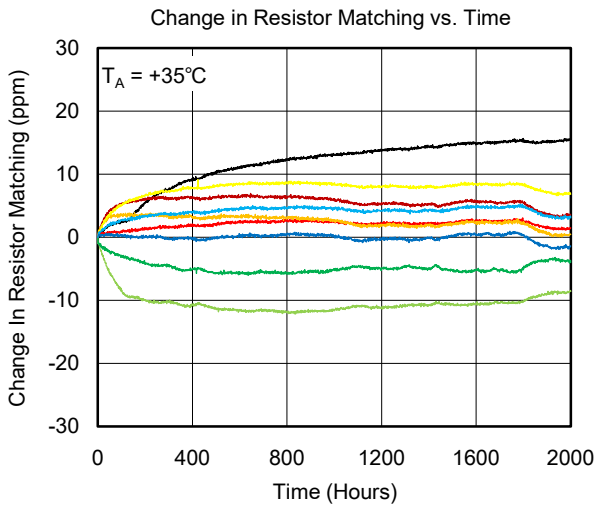

APPLICATION INFORMATION

Matching Specification

The definition of maximum resistor matching ratio for SGM9100 is the mismatch between the largest of the four resistors and the smallest of the four resistors. Table 1 provides detailed calculation example.

Table 1. SGM9100 Resistance Matching Rate Calculation Example

R ₁ (Ω)	R ₂ (Ω)	R ₃ (Ω)	R ₄ (Ω)	Max Resistor (Ω)	Match R ₁ (%)	Match R ₂ (%)	Match R ₃ (%)	Match R ₄ (%)	Match R _{MAX} (%)
10027.757	10027.847	10027.695	10027.872	10027.872	0.001147	0.000249	0.001765	0	0.001765

The differential amplifier application consisting of SGM9100-1 is shown in Figure 2.

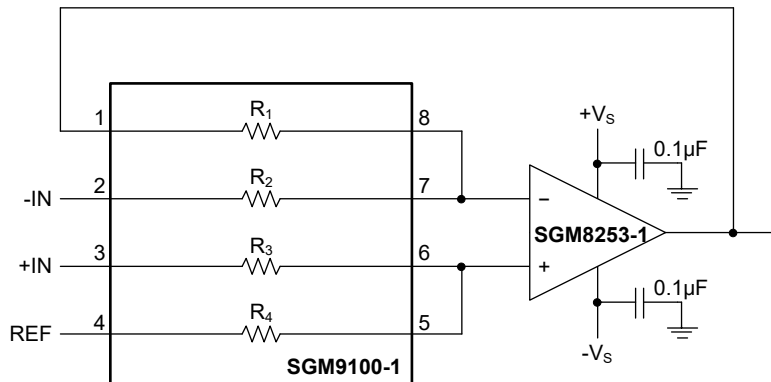

Figure 2. Differential Amplifier

The equation for calculating the output voltage (V_{OUT}) is as follows.

$$V_{OUT} = V_{IN+} \times \frac{R_4}{R_3 + R_4} \times \left(1 + \frac{R_1}{R_2} \right) - V_{IN-} \times \frac{R_1}{R_2} + V_{REF} \times \frac{R_3}{R_3 + R_4} \times \left(1 + \frac{R_1}{R_2} \right)$$

Assuming the resistance matching rate is 0.001% and both V_{IN+} and V_{REF} are connected to GND, the gain error can be calculated using the following equation.

$$V_{OUT} = -V_{IN-} \times \frac{R_1}{R_2}$$

$$G_{ACTUAL} = \frac{V_{OUT}}{V_{IN-}} = -\frac{R_1}{R_2} = -1.00001$$

$$G_{ERROR} = \frac{G_{ACTUAL} - G_{IDEAL}}{G_{IDEAL}} = \frac{-1.00001 - (-1)}{-1} = 0.00001 = 0.001\%$$

where:

G_{ACTUAL} and G_{IDEAL} are the actual gain and ideal gain of the circuit, respectively.
 G_{ERROR} is the gain error of the circuit introduced by the resistance matching rate.

APPLICATION INFORMATION (continued)

Exposed Pad Package

The SGM9100 is designed with an exposed pad to reduce internal temperature in high dissipation power applications. This pad is not connected to any other resistor terminal and can be tied to any voltage not exceeding the Absolute Maximum Ratings. Actually, this exposed pad has some parasitic capacitance relative to the resistors, and the parasitic capacitance value is specified in Electrical Characteristics table. Usually, it is better to connect this exposed pad to a quiet ground to reduce system noise and avoid interference.

Thermal Considerations

Each SGM9100 has four resistors. When current flows through these resistors, the chip temperature will rise. In actual applications, to avoid damaging the resistors, the power dissipation of SGM9100 cannot exceed the absolute maximum rating, and the maximum voltage between any pair of pins must be within the absolute maximum rating.

Besides, the SGM9100 thermal resistance coefficient of the package is also show in the Absolute Maximum Ratings section. Users can calculate the junction temperature of the chip based on the thermal resistance coefficient. The following Table 2 shows the detailed calculation method.

Table 2. The Junction Temperature Calculation

Key Parameters	Values
The Thermal Resistance Coefficient between Junction to Ambient, θ_{JA}	52°C/W
Power of Each Resistor	250mW
Total Power of SGM9100	1W
Ambient Temperature	+25°C
The Total Temperature Rise	52°C
The Junction Temperature Calculation Value	77°C

ESD

The SGM9100 is designed to tolerate Electrostatic Discharge levels of up to $\pm 1000V$ under the Human Body Model (HBM) and up to $\pm 1000V$ under the Charged Device Model (CDM). If the ESD exceeds this level in applications, the SGM9100's performance may decrease or even be damaged. In some applications that require high ESD standards, the SGM9100 requires an external protection diode to reduce large ESD strikes. Figure 3 shows two options to protect the SGM9100.

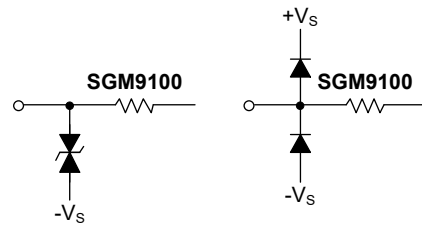

Figure 3. External Protection Circuit

TYPICAL APPLICATION CIRCUITS

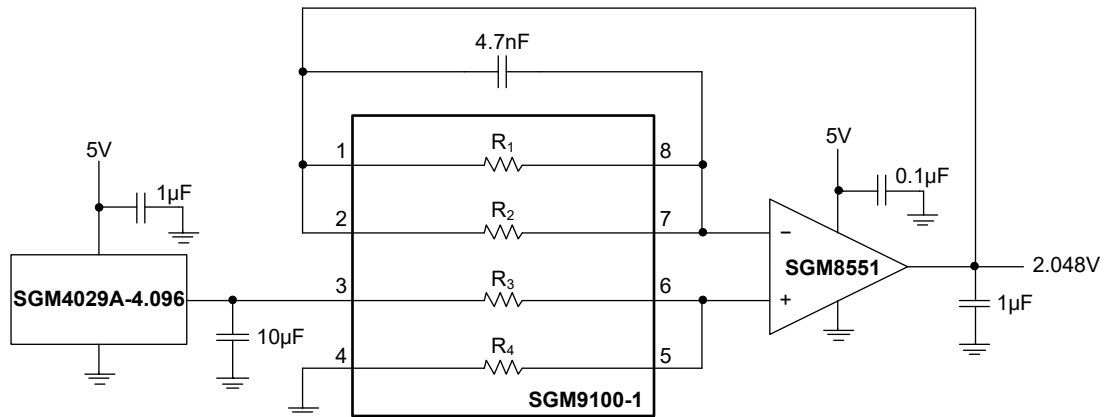

Figure 4. Low Noise Reference Divider with Operational Amplifier Input Bias Current Balancing

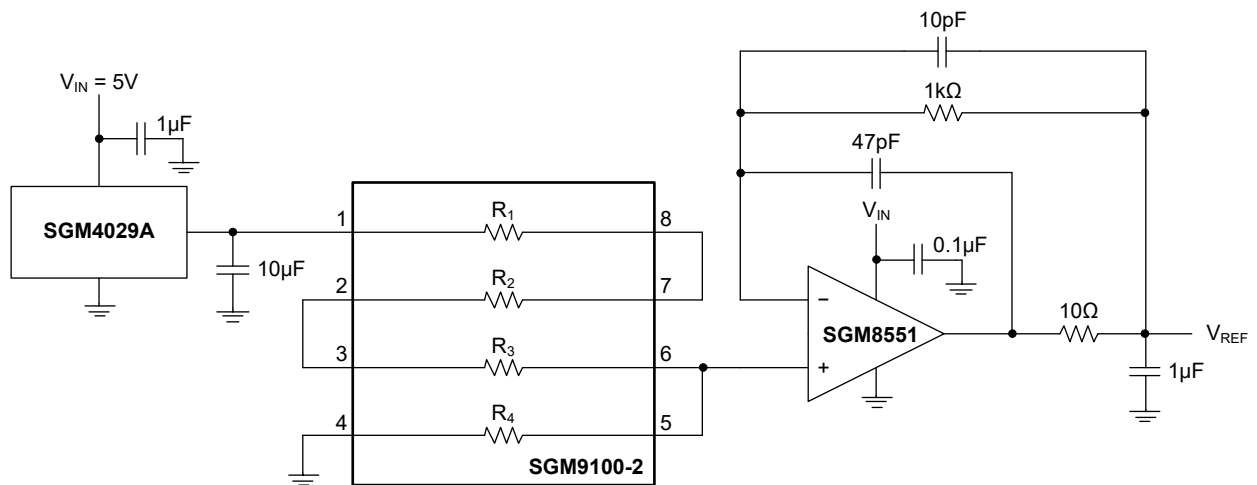

Figure 5. Low Power Voltage Reference Divide-by-4

REVISION HISTORY

NOTE: Page numbers for previous revisions may differ from page numbers in the current version.

JANUARY 2026 – REV.A to REV.A.1	Page
Updated Absolute Maximum Ratings section.....	2
Updated Electrical Characteristics section.....	4
Updated Application Information section.....	7

Changes from Original to REV.A (AUGUST 2024)	Page
Changed from product preview to production data.....	All

PACKAGE OUTLINE DIMENSIONS

MSOP-8 (Exposed Pad)

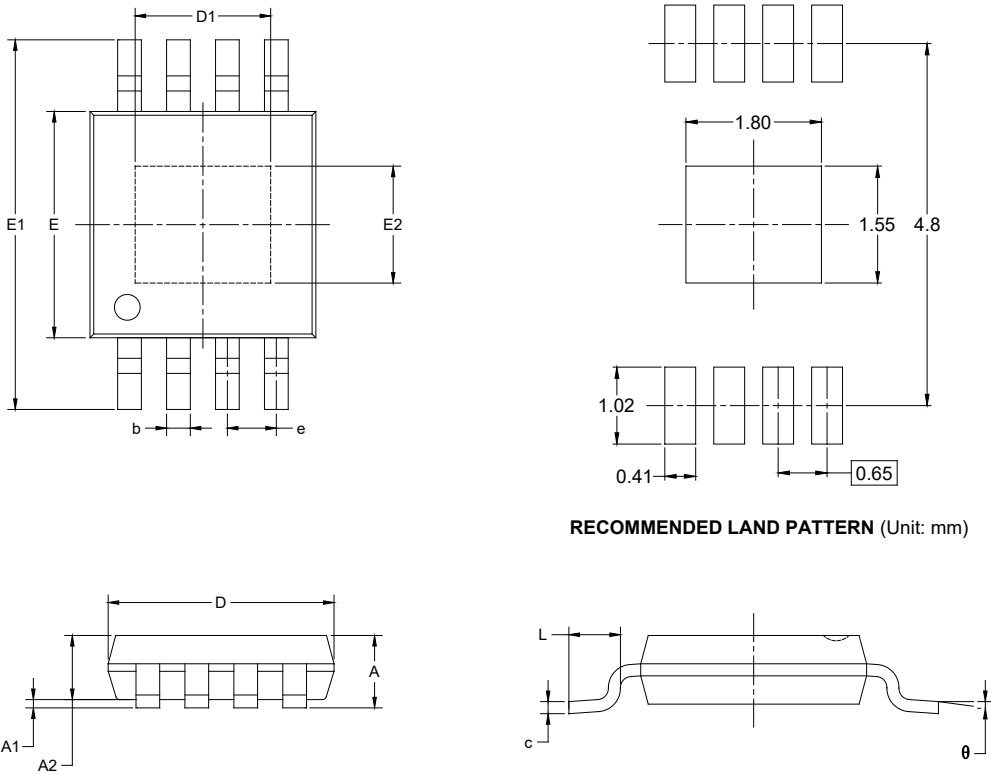

RECOMMENDED LAND PATTERN (Unit: mm)

Symbol	Dimensions In Millimeters		Dimensions In Inches	
	MIN	MAX	MIN	MAX
A	0.820	1.100	0.032	0.043
A1	0.020	0.150	0.001	0.006
A2	0.750	0.950	0.030	0.037
b	0.250	0.380	0.010	0.015
c	0.090	0.230	0.004	0.009
D	2.900	3.100	0.114	0.122
D1	1.700	1.900	0.067	0.075
e	0.65 BSC		0.026 BSC	
E	2.900	3.100	0.114	0.122
E1	4.750	5.050	0.187	0.199
E2	1.450	1.650	0.057	0.065
L	0.400	0.800	0.016	0.031
θ	0°	6°	0°	6°

NOTES:
 1. Body dimensions do not include mode flash or protrusion.
 2. This drawing is subject to change without notice.

PACKAGE INFORMATION

TAPE AND REEL INFORMATION

REEL DIMENSIONS

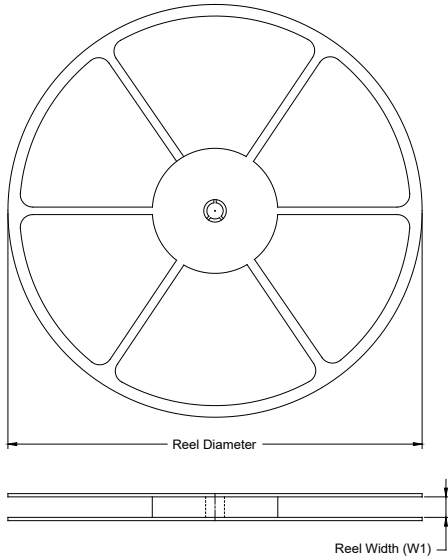

TAPE DIMENSIONS

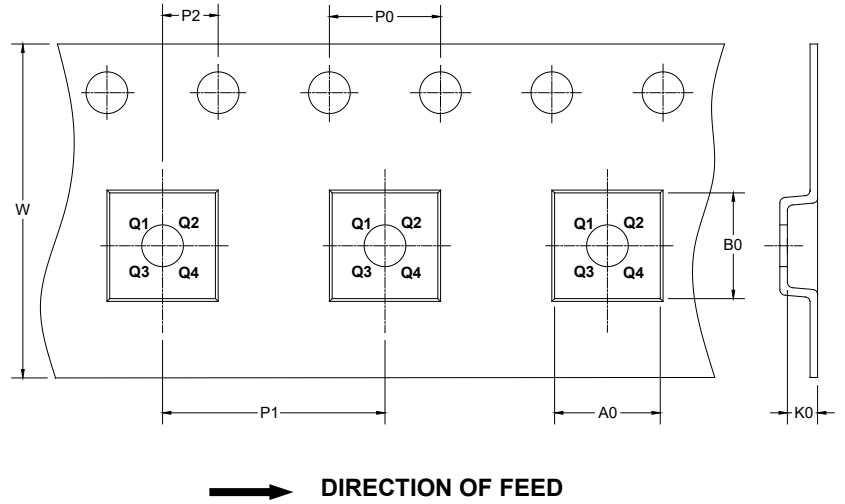

NOTE: The picture is only for reference. Please make the object as the standard.

KEY PARAMETER LIST OF TAPE AND REEL

Package Type	Reel Diameter	Reel Width W1 (mm)	A0 (mm)	B0 (mm)	K0 (mm)	P0 (mm)	P1 (mm)	P2 (mm)	W (mm)	Pin1 Quadrant
MSOP-8 (Exposed Pad)	13"	12.4	5.20	3.30	1.50	4.0	8.0	2.0	12.0	Q1

DD0001

PACKAGE INFORMATION

CARTON BOX DIMENSIONS

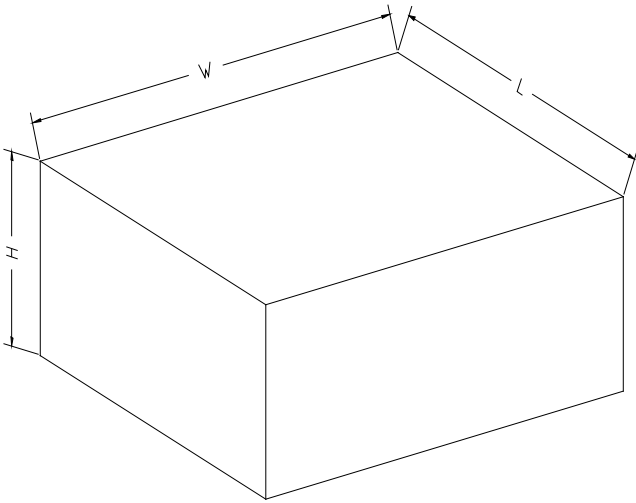

NOTE: The picture is only for reference. Please make the object as the standard.

KEY PARAMETER LIST OF CARTON BOX

Reel Type	Length (mm)	Width (mm)	Height (mm)	Pizza/Carton
13"	386	280	370	5

DD0002